

Water



NATO - CCMS

# Committee on the Challenges of Modern Society (NATO/CCMS)

## Drinking Water Microbiology

### NATO/CCMS Drinking Water Pilot Project Series

#### CCMS 128

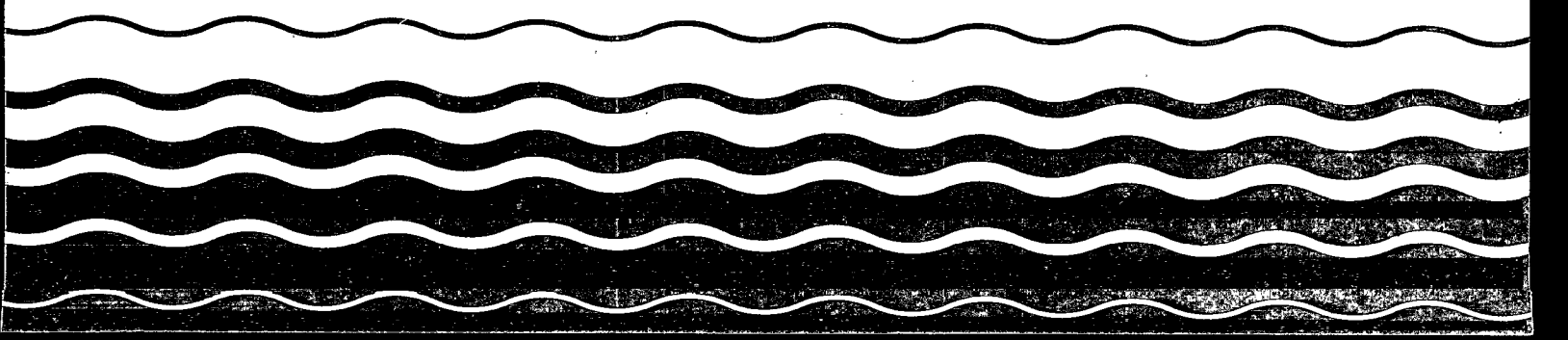

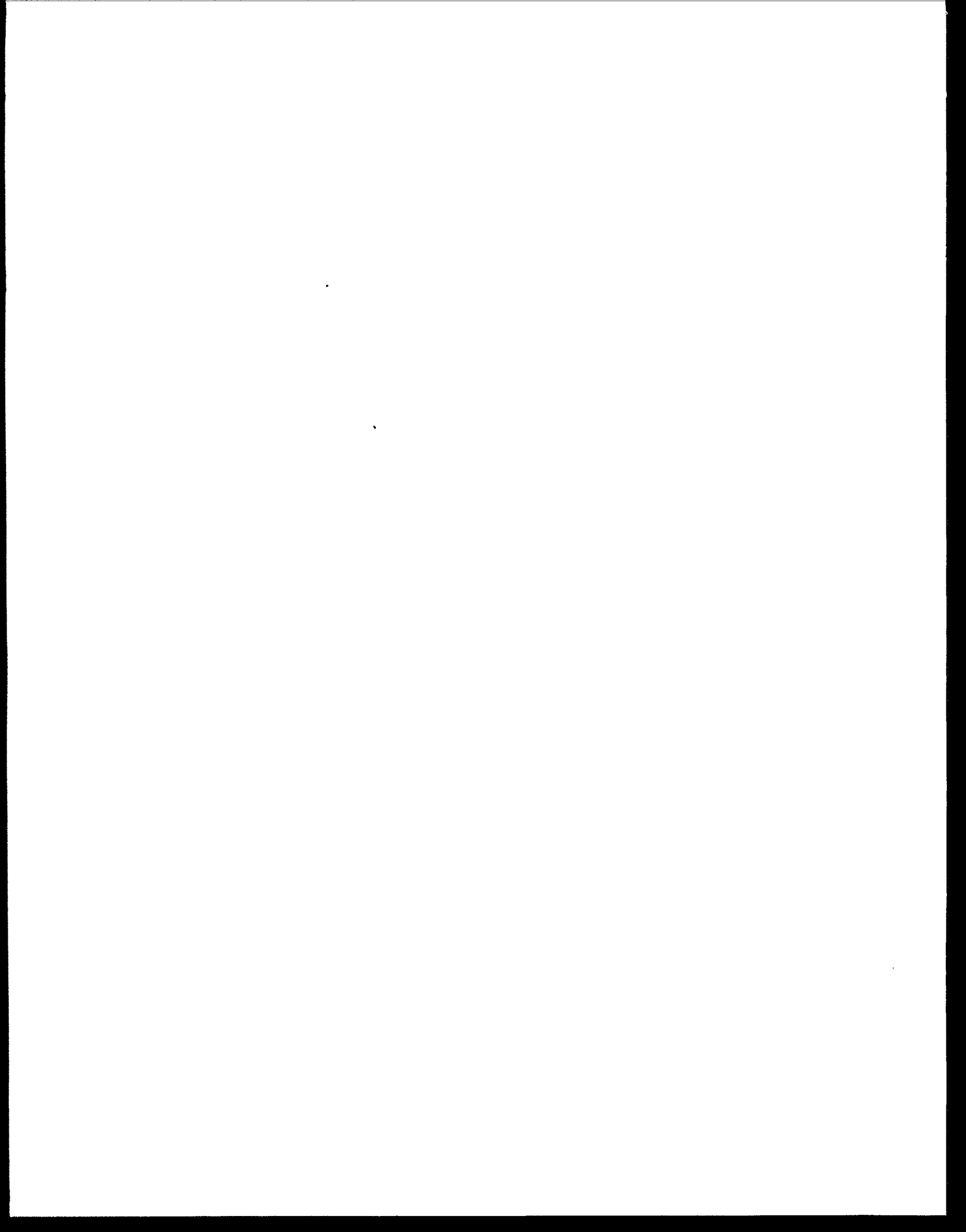

COMMITTEE ON THE CHALLENGES OF MODERN SOCIETY

(NATO/CCMS)

DRINKING WATER MICROBIOLOGY

Edited by:

Dean O. Cliver and Ruth A. Newman

With assistance from

Ross D. Pickford and Paul S. Berger  
Office of Drinking Water  
U.S. Environmental Protection Agency

NATO/CCMS Drinking Water Pilot Project Series

Joseph A. Cotruvo, Chairman

CCMS #128

1984

## DISCLAIMER

This report has been reviewed by the Office of Drinking Water, U.S. Environmental Protection Agency, and approved for publication. Approval does not signify that the contents necessarily reflect the views and policies of the U.S. Environmental Protection Agency, nor does mention of trade names or commercial products constitute endorsement or recommendation for use.

## FOREWORD

Many of the industrial Nations today face problems related to population, energy, and protection of the environment. In order to optimize use of the scientific and technical expertise from different countries, the Committee on the Challenges of Modern Society (CCMS) was created between the Allied Nations of the North Atlantic Treaty Organization (NATO). This international society of scientists strengthens ties among members of the North Atlantic Alliance and permits NATO to fill a broader social role with non-member countries. CCMS has been responding to the increasingly complex, technological problems facing modern society.

The Drinking Water Pilot Study was initiated by the U.S. Environmental Protection Agency (EPA) in order to address a broad spectrum of drinking water quality and health related issues. Six subject areas have been studied by a number of groups representing individuals from eleven NATO countries and three non-alliance countries with technical participation from many others. The conclusions and recommendations reached by the participants are hoped to allow national programs to focus on specific areas of water supply research and to bring out the most up-to-date technology and practices. However, the recommendations and conclusions do not necessarily reflect the policy of the U.S. or any other participating countries. The work of the Pilot Project has been covered in a summary report.

In addition three other major publications round out the work of the pilot study - two being reports of international symposia "Oxidation Techniques in Drinking Water Treatment". (CCMS-111; EPA-570/9-79-020) and "Adsorption Techniques in Drinking Water Treatment" (CCMS-112; EPA-570/9-84-005); and the third being this document. EPA has been proud and pleased to associate with such a fine group of scientists in this import work and hopes to see these relationships continued into the future.

Joseph A. Cotruvo, USEPA  
Chairman, Drinking Water Pilot Project  
NATO/CCMS

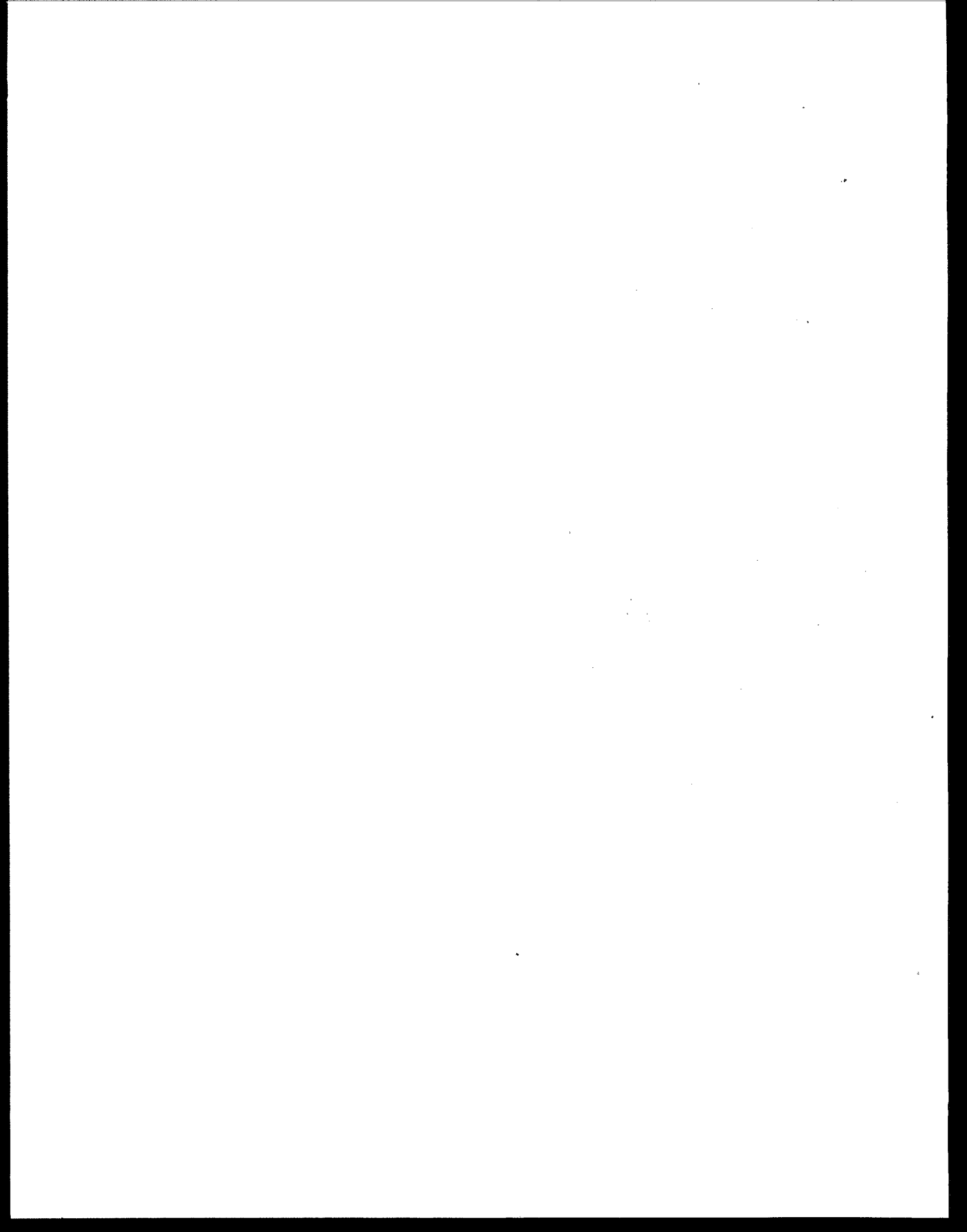

FRAU PROFESSOR DR. GERTRUD MULLER

1919 - 1980

Frau Professor Dr. Gertrud Müller, Leitender Direktor and Professor, Abt. "Spezielle Umwelthygiene, Humanökologie und Gesundheitstechnik," Institute für Wasser-, Boden- und Lufthygiene des Bundesgesundheitsamtes, Berlin, Federal Republic of Germany, departed this world and the community of scientists on 30 April 1980, ending a long and outstanding career as a water and wastewater microbiologist and environmental hygienist. She was a recognized leader in her fields of endeavor in her own country and a frequent participant in international professional activities. Among her more than 200 scientific publications were several books that are regarded as classics in their fields. Those who knew and worked with her were invariably impressed by the enthusiasm and the positive approach with which she addressed whatever she did. We, her colleagues in the writing, compilation, and editing of Project Area III - Microbiology of the CCMS Pilot Study on Drinking Water Supply Problems, fondly dedicate this report of our work to her. She has been an inspiration to us in this undertaking and will surely continue to be one for our work in the years to come.

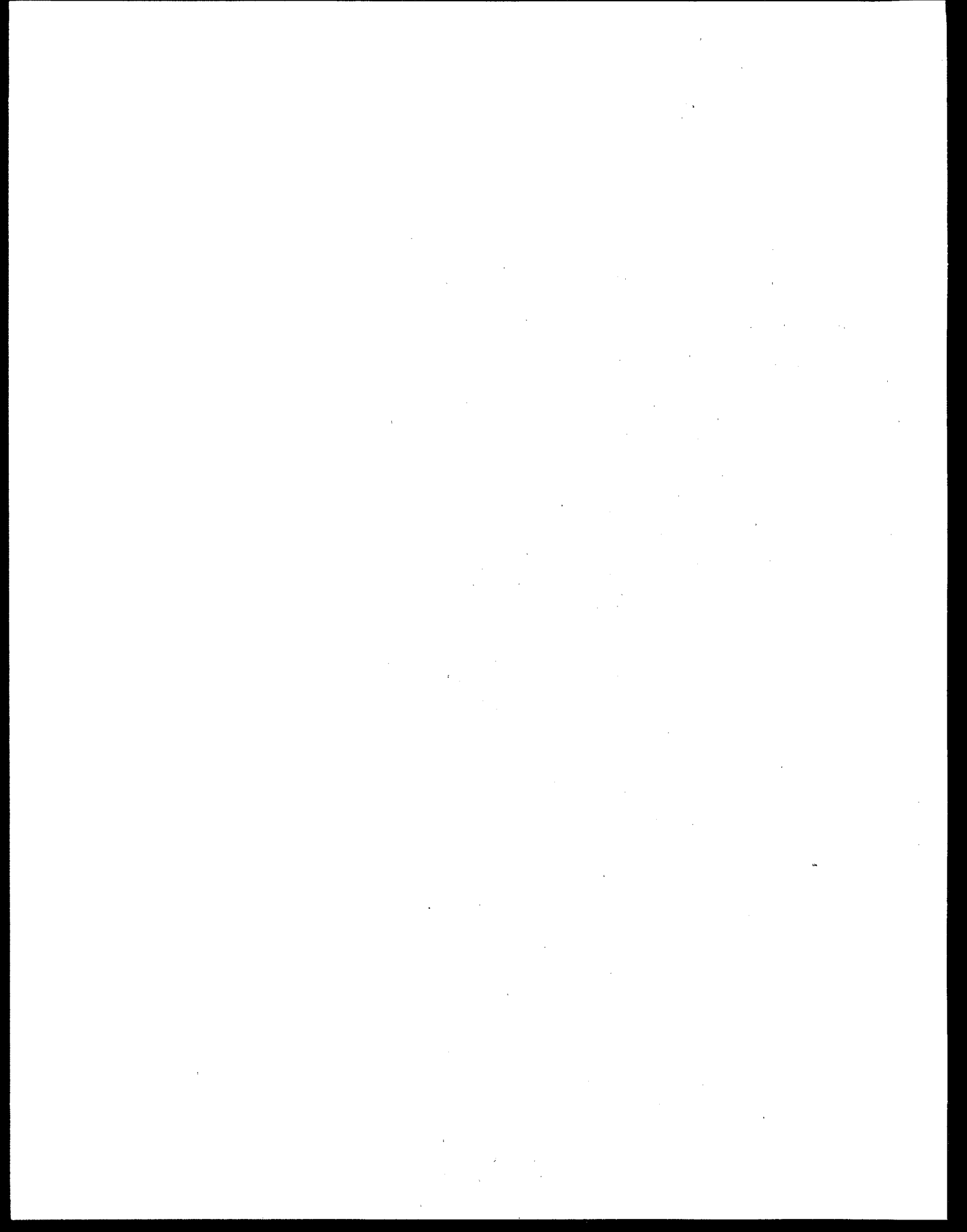



TABLE OF CONTENTS

	Pages
List of participants . . . . .	x
Preface . . . . .	xviii
Introduction . . . . .	xxi
List of tables . . . . .	xxvi
List of figures . . . . .	xxxii
A. RAW WATER . . . . .	1
1. Microbiology of groundwater . . . . .	7
a. Definition of groundwater . . . . .	9
b. Occurrence of indigenous microorganisms in groundwater . . . . .	10
c. Fate of organic substances in groundwater . . . . .	13
d. New trends in the disposal of sludge and sewage effluent . . . . .	14
e. Factors affecting survival in soil and groundwater . . . . .	18
f. Occurrence of endotoxins in groundwater . . . . .	25
g. Criteria for evaluating groundwater quality . . . . .	27
h. Protection of groundwater . . . . .	30
i. Conclusion and recommendations . . . . .	31

TABLE OF CONTENTS -- Continued

	Pages
2. Microbiology of surface water . . . . .	31
a. Occurrence of microorganisms in surface water . . . . .	31
b. Lakes and reservoirs . . . . .	40
c. Toxic cyanobacteria in raw water supplies .	43
d. Sampling, transport, and microbiological requirements for raw surface water . . . . .	46
e. Protection of surface water . . . . .	48
3. Survey of the bacteriological quality of raw water supplies from nine countries . . . . .	50
a. Size of waterworks, source of raw water, and sampling frequencies . . . . .	51
b. Bacteriological quality of raw water supplies . . . . .	55
c. Conclusion . . . . .	55
4. Summary . . . . .	61
B. MICROBIAL PATHOGENS TRANSMITTED BY WATER . . . . .	63
1. Categories and properties of waterborne microbial pathogens of humans . . . . .	65
a. Bacteria . . . . .	65
(i) <u>Salmonella</u> . . . . .	65
(ii) <u>Shigella</u> . . . . .	71
(iii) <u>Yersinia enterocolitica</u> . . . . .	73
(iv) <u>Enteropathogenic Escherichia</u> <u>coli</u> . . . . .	76
(v) <u>Francisella tularensis</u> . . . . .	78

TABLE OF CONTENTS -- Continued

	Pages
(vi) <u>Leptospira</u> . . . . .	80
(vii) <u>Vibrio cholerae</u> . . . . .	82
(viii) <u>Campylobacter</u> . . . . .	85
(ix) Opportunistic pathogens . . . . .	87
b. Viruses . . . . .	90
c. Protozoa and metazoa . . . . .	105
(i) <u>Entamoeba histolytica</u> . . . . .	105
(ii) <u>Giardia lamblia</u> . . . . .	107
(iii) <u>Naegleria fowleri</u> . . . . .	111
(iv) <u>Acanthamoeba</u> species . . . . .	113
(v) Helminths . . . . .	114
d. Gastroenteritis of undeter- mined etiology . . . . .	116
2. Sources of waterborne pathogens . . . . .	120
3. Persistence and death of pathogens in water . . . . .	126
4. Infectivity of waterborne pathogens . . . . .	135
5. Epidemiology of waterborne infectious diseases . . . . .	139
6. Summary . . . . .	157
7. Recommendations . . . . .	158

TABLE OF CONTENTS -- Continued

	Pages
C. INDICATOR SYSTEMS FOR MICROBIOLOGICAL QUALITY AND SAFETY OF WATER . . . . .	168
1. Established viable indicator systems . . . . .	169
a. Colony count . . . . .	169
b. Total coliforms . . . . .	174
c. Thermo-tolerant coliforms and <u>Escherichia coli</u> . . . . .	180
d. Fecal streptococci . . . . .	184
e. Sporeformers . . . . .	193
2. Proposed viable indicators . . . . .	197
a. Coliphages . . . . .	198
b. Vaccine polioviruses . . . . .	202
c. <u>Pseudomonas aeruginosa</u> . . . . .	206
d. <u>Klebsiella</u> . . . . .	209
e. <u>Bifidobacterium</u> . . . . .	213
f. <u>Candida albicans</u> . . . . .	219
g. <u>Vibrio</u> . . . . .	222
h. <u>Aeromonas</u> . . . . .	225
3. Other indicators of microbial quality . . . . .	232
a. Limulus amebocyte lysate . . . . .	232
b. Adenosine triphosphate . . . . .	235
c. Fecal sterols . . . . .	240

TABLE OF CONTENTS -- Continued

	Pages
4. Potentials for mechanization, automation, and shorter read-out times . . . . .	246
a. Radioactive isotope methods . . . . .	247
b. Impedance methods . . . . .	252
c. Automated sampling, plating and incubation . . . . .	257
d. Automated plate counting . . . . .	259
e. Automated enzymatic methods . . . . .	263
f. Rapid thermo-tolerant coliform MF method . . . . .	269
g. Presence absence test . . . . .	271
h. Membrane filter procedure for US Standard plate count . . . . .	281
i. Epifluorescence -- total cell count . . . . .	283
5. Summary . . . . .	287
6. Recommendations . . . . .	291
 D. TESTING AND STANDARDS . . . . .	 293
1. Sampling and sample storage . . . . .	294
2. Total coliform testing, membrane filter technique . . . . .	294
3. Total coliform testing, multiple tube technique . . . . .	305
4. Thermo-tolerant (fecal) coliform testing, membrane filter technique . . . . .	313
5. Thermo-tolerant (fecal) coliform testing, multiple tube technique . . . . .	313
6. Colony count . . . . .	322

TABLE OF CONTENTS -- Continued

	Pages
7. Miscellaneous . . . . .	326
8. Summary and conclusions . . . . .	326
9. Recommendations . . . . .	327
 E. MICROBIOLOGY OF WATER TREATMENT AND DISINFECTION . . . . .	      329
1. Storage reservoirs . . . . .	329
2. Coagulation . . . . .	339
3. Sand filtration . . . . .	348
4. Activated carbon filtration . . . . .	358
5. Disinfection . . . . .	361
a. Chlorination . . . . .	361
b. Ozone treatment . . . . .	375
c. Chlorine dioxide . . . . .	386
d. Iodine . . . . .	389
6. Summary . . . . .	393
7. Recommendations . . . . .	396
 F. DISTRIBUTION SYSTEMS . . . . .	 397
1. Service reservoirs . . . . .	398
a. Direct contamination from sewage . . . . .	398
b. Contamination of open service reservoirs . . . . .	398
c. Contamination from leakage . . . . .	399
d. Growth in bottom deposits . . . . .	400

TABLE OF CONTENTS -- Continued

	Pages
2. Aftergrowth . . . . .	401
a. Influence of nature of raw water and methods of treatment on aftergrowth . . . . .	401
b. Accumulation of organic debris in dead ends and other protected areas . . . . .	404
c. Interrelationships between organic matter, bacterial growth, and animals in the distribution systems . . . . .	405
d. Chemical changes in distri- bution systems . . . . .	406
3. Growth on materials . . . . .	409
a. Ability of various microorganisms to grow on some materials used in dis- tribution and plumbing systems . . . . .	409
b. Problems that can be caused by microbial growth . . . . .	411
c. Methods of testing materials . . . . .	413
d. Standards and regulations relating to materials in contact with water . . . . .	416
e. Growth on atmospheric volatile organic chemicals . . . . .	417
4. Back-siphonage and cross-connections . . . . .	419
a. Types of back-siphonage and cross- connections and risks involved . . . . .	419
b. Regulations concerning back-siphonage . . . . .	421
c. Mechanical devices and hydraulic safeguards . . . . .	421

TABLE OF CONTENTS -- Continued

	Pages
5. Main laying and repair . . . . .	422
a. Codes of practice to prevent contamination . . . . .	422
b. Problems with jointing materials . . . . .	423
c. Cleaning, disinfection, and sampling procedures . . . . .	424
d. Acceptable standards . . . . .	426
6. Summary . . . . .	426
7. Recommendations . . . . .	429
G. TECHNOLOGICAL ASPECTS . . . . .	431
1. Biodeterioration of materials . . . . .	432
a. Biodeterioration of rubber sealing rings . . . . .	432
b. Biodeterioration of sealants and mastics . . . . .	437
2. Microbial growth on resins and filter media . . . . .	438
a. Filters . . . . .	439
b. Ion exchangers . . . . .	439
c. Portable filters . . . . .	439
d. Water softeners that add phosphorus . . . . .	440
e. Conclusion . . . . .	440
3. Hydraulic effects of microbial growth . . . . .	441
a. Types and diameters of pipes . . . . .	441
b. Microbial oxidation of manganese in pipes . . . . .	441



TABLE OF CONTENTS -- Continued

	Pages
c. Microbial growth from improper installation of household equipment . . . . .	442
d. Microbial growth from cross-connections . . . . .	442
4. Microbially mediated chemical cycles . . . . .	443
a. Microbial manganese oxidation affecting wells and water distribution systems . . . . .	443
b. Iron and sulfur bacteria corroding well casings and other structures . . . . .	444
5. Drinking water supply for ships . . . . .	449
6. Water in containers . . . . .	453
7. Summary . . . . .	455
8. Recommendations . . . . .	456
GENERAL SUMMARY . . . . .	457
GENERAL RECOMMENDATIONS . . . . .	471
REFERENCES . . . . .	474

## LIST OF PARTICIPANTS

## Project Area III: Microbiology

Canada

Mr. J. A. Clark, Supervisor  
Microbiology Section, Laboratory Services Branch  
Ministry of the Environment  
P.O. Box 213  
Rexdale, Ontario

Dr. B. J. Dutka, Head  
Microbiology Laboratories  
Applied Research Division  
Canada Centre for Inland Waters  
867 Lakeshore Rd., P.O. 5050  
Burlington, Ontario L7R 4A6

Dr. Paul R. Gorham  
Department of Botany  
University of Alberta  
Edmonton, Alberta T6G 2E9

Dr. Richard S. Tobin - Leader, Topic C & National Contact  
Criteria Section  
Environmental Standards Division  
Environmental Health Centre  
Tunney's Pasture  
Ottawa, Ontario K1A 0L2

Denmark (not a participating country)

Prof. Dr. Gunnar G. Bonde  
Institute of Hygiene  
University of Aarhus  
Aarhus

Denmark (cont.)

Dr. Kaj Krongaard Kristensen  
Vandkvalitetsinstitutet  
Agern Alle 11  
2970 Hørsholm

Federal Republic of Germany

Professor Dr. Gertrud Müller - Leader, Topic G  
Institut für Wasser-, Boden- und Lufthygiene  
des Bundesgesundheitsamtes  
Postfach  
D-1000 Berlin 33

Dr. Peter Scheiber - National Contact  
Medizinal-Untersuchungsamt  
6100 Darmstadt  
Wilhelminstr. 2  
Postfach 11 07 61

Professor Dr. Reinhard Schweisfurth  
Universität des Saarlandes  
Institut für Hygiene und Mikrobiologie  
Universitätskliniken, Medizinische Fakultät  
D-665 Homburg

Professor Dr. R. Schubert  
Department of General & Environmental Hygiene  
Centre of Hygiene  
Paul-Erlich-Strasse 40  
6 Frankfurt a/M

France

Dr. Jean-Claude Block  
Laboratoire de Microbiologie  
U. E. R. d'Ecologie  
Université de Metz  
1, rue des Recollets  
57000 Metz

Professor Dr. J. M. Foliguet - Leader, Topic B  
Laboratoire d'Hygiène et de Recherche en Santé Publique  
Université de Nancy 1  
Faculté de Médecine "B"  
Avenue de la Forêt de Haye  
54500 Vandoeuvre-les-Nancy

France (cont.)

Dr. P. Hartemann - Leader, Topic B  
Laboratoire d'Hygiène et de Recherche en Santé Publique  
Université de Nancy 1  
Faculté de Médecine "B"  
Avenue de la Forêt de Haye  
54500 Vandoeuvre-les-Nancy

Professor H. Leclerc  
Institut National de la Santé et de la Recherche Médicale  
Unité No. 146  
Ecotoxicologie Microbienne  
Domaine du C.E.R.T.I.A.  
369, rue Jules Guesde  
59650 Villeneuve-D'Ascq

P. A. Trinel  
Institut National de la Santé et de la Recherche Médicale  
Unité No. 146  
Ecotoxicologie Microbienne  
Domaine du C.E.R.T.I.A.  
369, rue Jules Guesde  
59650 Villeneuve-D'Ascq

Dr. J. Vial - National Contact  
Laboratoire Régional d'Hygiène  
de l'Homme et de son Environnement  
Institut Pasteur de Lyon  
77, rue Pasteur  
69300 - Lyon Cedex 2

Greece

Professor J. A. Papadakis - National Contact  
Athens School of Hygiene  
L. Alexandras 196  
Athens

Israel

Dr. U. Bachrach  
Department of Molecular Biology  
The Hebrew University - Hadassah Medical School  
Jerusalem, Israel

Israel (cont.)

Professor Dr. Yehuda Kott - National Contact  
Environmental & Water Resources Engineering  
Technion-Israel Institute of Technology  
Technion City, Haifa 32 000

The Netherlands

Dr. A. H. Havelaar  
National Institute of Public Health  
P.O. Box 1  
Bilthoven

Dr. H. J. Kool - Leader, Topic E and National Contact  
Rijksinstituut voor Drinkwatervoorziening  
Postbus 150  
2260AD Leidschendam

Dr. M. van Schothorst  
Laboratory for Zoonoses & Food Microbiology  
Rijks Instituut voor de Volksgezondheid  
Antonie van Leeuwenhoeklaan 9  
Postbus 1, Bilthoven

Norway

Dr. J. Kvittingen  
Moholtlia 30  
7000 Trondheim

Dr. Jørgen Lassen  
National Institute of Public Health  
Postuttak  
Oslo 1

LTC, D.V.M. Jens J. Nygård - Leader, Topic A  
Assistant Chief Army Veterinarian  
Norwegian Institute for Water Research  
Gaustadalléen 25  
P.O. Box 333 Blindern  
Oslo 3

Norway (cont.)

Dr. Tov Omland - National Contact  
Norwegian Defence  
Microbiological Laboratory  
National Institute of Public Health  
Postuttak  
Oslo 1

Mrs. Kari Ormerod  
Norwegian Institute for Water Research  
P.O. Box 333, Blindern  
Oslo 3

Sweden (not a participating country)

Dr. Thor Axel Stenström - Observer  
The National Bacteriological Laboratory  
S-105 21 Stockholm

United Kingdom

Dr. Norman P. Burman - Leader, Topic F  
Formerly, Manager of Thames Water Authority  
Metropolitan Water Services  
9, Derby Road  
Surbiton  
Surrey, KT5 9AY

Mrs. L. M. Evison  
Department of Civil Engineering  
University of Newcastle Upon Tyne  
Clairmont Road  
Newcastle Upon Tyne  
NE1 7RU

Dr. J. W. Ridgway  
District Division  
Water Research Centre  
P.O. Box 16, Henley Road  
Medmenham, Marlow, Buckinghamshire  
SL 7 2HD

United Kingdom (cont.)

Dr. J. S. Slade, Virologist  
Thames Water Authority  
New River Head Laboratories  
177 Rosebery Avenue  
London, EC1R 4TP

Miss J. Stevens - Leader, Topic F & National Contact  
Chief Microbiologist  
Thames Water Authority  
New River Head Laboratories  
177 Rosebery Avenue  
London, EC1R 4TP

United States

Dr. Elmer W. Akin  
Research Virologist  
Environmental Protection Agency  
HERL (Health Effects Research Lab.)  
26 W. St. Clair St.  
Cincinnati, Ohio 45268

Dr. J. D. Buck  
Marine Sciences Institute  
Marine Research Lab.  
P.O. Box 278  
Noank, Connecticut 06340

Dr. S. L. Chang  
1035 Juanita Drive  
Walnut Creek, California 94595

Professor Dean O. Cliver - Project Leader  
Food Research Institute  
University of Wisconsin  
1925 Willow Drive  
Madison, Wisconsin 53706

Professor R. R. Colwell  
Department of Microbiology  
University of Maryland  
College Park, Maryland 20742

United States (cont.)

Professor Koby T. Crabtree  
Professor of Microbiology  
Chairman, Center System - Department of Biological Sciences  
University of Wisconsin  
518 So. 7th Avenue  
Wausau, Wisconsin 54401

Mr. Edwin E. Geldreich, Chief  
Microbiological Treatment Branch  
Water Supply Research Division  
Municipal Environmental Research Lab.  
U.S. Environmental Protection Agency  
Cincinnati, Ohio 45268

Dr. B. L. Green  
Department of Environmental Sciences  
Marshall Hall  
University of Massachusetts  
Amherst, Massachusetts 01003

Mr. Arnold E. Greenberg - Leader, Topic D  
Chief, Bioenvironmental Laboratories  
California Department of Health  
2151 Berkeley Way  
Berkeley, California 94704

J. E. Hobbie  
The Ecosystems Center  
Marine Biological Laboratory  
Woods Hole, Massachusetts 02543

Dr. John C. Hoff  
Microbiological Treatment Branch  
Water Supply Research Division  
Municipal Environmental Research Lab.  
U.S. Environmental Protection Agency  
Cincinnati, Ohio 45268

Professor Warren Litsky  
Department of Environmental Sciences  
Marshall Hall  
University of Massachusetts  
Amherst, Massachusetts 01003



United States (cont.)

Ruth Newman - Project Editor  
Food Research Institute  
University of Wisconsin  
1925 Willow Drive  
Madison, Wisconsin 53706

Melvin P. Silverman  
National Aeronautics & Space Administration  
Ames Research Center  
Moffett Field, California 94035

Professor Otis J. Sproul, Chairman  
470 Hitchcock Hall  
Ohio State University  
Department of Civil Engineering  
2070 Neil Avenue  
Columbus, Ohio 43210

Susan Stramer  
Food Research Institute - Department of Bacteriology  
University of Wisconsin  
1925 Willow Drive  
Madison, Wisconsin 53706

Dr. S. W. Watson  
Woods Hole Oceanographic Institute  
Woods Hole, Massachusetts 02543

Dr. C. K. Wun  
Department of Environmental Sciences  
Marshall Hall  
University of Massachusetts  
Amherst, Massachusetts 01003

## PREFACE

The Pilot Study on Drinking Water Supply Problems was performed under the auspices of the Committee on the Challenges of Modern Society, to examine problems of special concern to industrialized nations. Increasing technology has helped developed countries deal with some of the drinking water supply problems that still trouble less affluent nations, but other problems arising from industrialization and urbanization are just beginning to surface.

This report on the microbiology of drinking water was compiled by approximately 50 experts from 11 countries (cf. preceding list). Each of the seven topics comprising the report was led by a person from a different country, and most of the working groups were international in composition.

We intended to incorporate into this project all aspects of drinking water microbiology that have practical significance. We considered the entire continuum from the source water, through treatment and delivery to the consumer. We included organisms which may affect human health directly, those which may have an indirect influence (such as indicator organisms), and those which cause technologic problems in the provision of safe drinking water. Thus, the scope of our undertaking may well be broader than that of any previous project in the area of drinking water microbiology.

On the other hand, extreme breadth necessarily limits depth. We chose to try to define the problems, identify available solutions, and propose research that is required to produce solutions that do not yet exist. Both published and unpublished research results have been included; but we have often directed the reader to a review on some broad subject, rather than a multitude of older source articles. We have tried to produce a text which is useful and meaningful to a career microbiologist who may not be an expert on the aspects of drinking water microbiology. The summary of the report is directed to those with a less specialized technical background.

The seven topics are intended to cohere as much as possible, but the topic leaders have chosen a variety of formats on the basis of suitability to the kinds of material they had to present. The references cited are principally those which are likely to be available in technical libraries of industrialized nations.

Topic A, led by Dr. J. J. Nygård of Norway, deals with the microbiology of raw water. Groundwater and surface water are considered separately, and the report includes a survey of microbiologic experience with raw water in several countries.

Topic B, led by Prof. J. M. Foliguet with Dr. P. Hartemann and assisted by Dr. J. Vial, all of France, concerns the pathogens which are transmissible through drinking water. Following a survey of the properties of individual pathogenic species, the report addresses the general questions of sources, persistence, and infectivity of waterborne pathogens and the compilation of statistics on waterborne disease.

Topic C, led by Dr. R. S. Tobin of Canada, discusses indicator systems. This includes both indicators which are already established and in general use as well as others which are still at the research stage. Some are primarily indicators of fecal contamination, whereas others relate to different aspects of microbiologic quality. The discussion also includes techniques presently under study which are designed to be potentially more rapid or convenient and do not rely upon the growth of viable organisms.

Topic D, compiled by Mr. A. E. Greenberg of the United States from materials supplied by respondents in thirteen countries, concerns testing and standards for drinking water. Tables are used to make comparisons among nations as to their requirements or recommendations for sampling and testing procedures. Methods for determining coliforms and thermo-tolerant coliforms (*Escherichia coli*) are emphasized. The existence and effects of standards are compared.

Topic E, led by Dr. H. J. Kool of the Netherlands, addresses processes used in drinking water treatment. The effects of various unit processes are considered from the microbiologic standpoint. Where possible, effects on pathogens are contrasted with effects on indicator organisms.

Topic F, which concerns the distribution of drinking water, was written by Dr. N. P. Burman and Miss J. K. Stevens,

both of the United Kingdom. The discussion emphasizes protecting the microbiologic quality of finished water during storage and on the way to the consumers. Means of preventing growth of organisms within the system as well as contamination by organisms from without are considered.

Topic G, led by Prof. G. Müller of the Federal Republic of Germany, deals with technological aspects of potable water microbiology. One broad area of discussion concerns the influence of microorganisms upon the structures or functions of devices used in treating and distributing drinking water. Another area is concerned with water held in containers. These include drinking water reservoirs aboard ships, or cans and bottles used either for commercial or emergency use.

The summary which concludes the text of the report is intended to be of value to both policymakers and the public. It attempts to provide an overview, from the microbiologic standpoint, of the technical and institutional problems involved in providing a safe and quantitatively adequate supply of drinking water from whatever raw water is available. It also emphasizes the need for continuing research to fill the gaps in present knowledge.

## INTRODUCTION

Throughout the course of history, the development of a safe drinking water supply has been crucial to the public health of nations. Drinking water is a necessity and approximately 2 liters/day are required to sustain life. Despite the body's many special mechanisms for conserving water, substantial quantities are lost each day and must be replaced promptly. Much of the replacement is derived from water that is present in food, some is a product of metabolism; the rest must be obtained by drinking water or other beverages, all of which contain water. Water must be drunk, even if what is available is unsafe, in the sense that drinking it may produce adverse effects upon health. Postponement of meeting the body's needs for beverage water can lead to extreme illness and death within a very few days. Because people have virtually no option but to drink the water that is available to them, it is a fundamental responsibility of governments to ensure a continuous supply of safe drinking water, to provide alternative sources, or provide for conservation.

Water does not occur in an absolutely pure state anywhere in the world. By and large, the chemical impurities in both ground and surface waters govern, through their chemistry, the kinds of native bacterial populations that ordinarily grow in the water. The organisms are generally found in low numbers and are of little public health consequence as long as the water contains minimal concentrations of organic, nitrogen, and phosphorus compounds as basal nutrients. Pollution of both ground and surface water supplies, much of which is domestic sewage, is becoming a serious problem for industrialized countries. These wastes not only contain pathogenic microorganisms, but also varying amounts of basal nutrients which can support the growth of various microorganisms and as a result, cause taste, odor, or fouling problems for some water supplies.

Historically, the agents causing typhoid fever, bacillary dysentery, and cholera have been of primary concern to the sanitary microbiologist and public health officials.

These diseases are only rarely observed now in industrial countries which efficiently practice modern means of water treatment and waste disposal. Other disease producing bacteria, viruses, and protozoa, including Giardia lamblia, are receiving attention probably because of our general awareness of the organisms in some source waters and our ability to recover them from the water. Attention has focused, too, on the opportunistic pathogens which are primarily saprophytic and can cause disease in debilitated individuals. These bacteria have the ability to multiply in situ and in distribution systems while the more fastidious bacteria, viruses, and protozoan cysts cannot compete in the aquatic environments.

Pathogens cannot usually be sought as a means of determining the microbiologic quality or safety of drinking water. Levels of pathogens in finished water and in highly protected source waters are essentially nil, most of the time, because pathogens are likely to be so fastidious that only highly specialized laboratory techniques may allow them to be detected. Therefore, bacterial species which are generally nonpathogenic, but are more readily cultivated in the laboratory, have come to be used as indicators of water quality and safety. Some of these indicators may be taken as evidence that water is contaminated with feces. Some of these indicators can show that water treatment has been inadequate or that an abnormal or undesirable situation exists, but none can be directly correlated with the presence of specific pathogens. Other indicator systems, some of which do not entail the growth of viable organisms from a sample, have been proposed to detect endotoxin or ATP or to provide results more rapidly than is possible by techniques presently in routine use. No microbiologic indicator system will serve all of these purposes, nor does any system serve even a single purpose perfectly. Nevertheless, the coliform indicator system has been used for many years in monitoring water quality and, with minor refinements, has stood the test of time reasonably well.

Routine testing for microbiologic indicators has been the traditional means of evaluating the safety and reliability of public water supplies for more than 80 years. Sampling and microbiologic testing procedures to determine drinking water quality have been established in every industrialized nation, yet the procedures used are not always the same. Potentially significant differences exist among nations as to where and with what frequency water samples are to be taken, how samples are to be tested when they

reach the laboratory, how the laboratory test results are to be interpreted, and what remedial action is appropriate when indicator test results exceed established norms. In comparing activities it is important to note that commendable and much-needed efforts are already under way toward standardizing microbiologic testing of water through a number of existing organizations.

Water for potable use must be taken from the best source available to the community. If the quality of the source does not meet appropriate criteria and standards for safety, treatment must be developed in order to protect the public health. Water treatment techniques are well established and sophisticated in industrialized nations. This supports the observation that waterborne disease is relatively rare in these countries, even though many of the suppliers are obliged to prepare drinking water from sources that are not ideal in purity. However, even procedures that have long been in use at a given location may have to be modified if raw water quality suddenly deteriorates, if the public that is served demands a higher degree of water purification than was previously practiced, or if reductions in the treatment costs, in terms of money or energy, are sought. As a result of long experience, we know the effects each of the major water treatment procedures are expected to produce upon the pathogens that may be present in the water and what effect changes in treatment may have on the indicator systems by which the quality of the water is monitored. Few unit processes in water treatment, other than disinfection, have been designed specifically to act upon the microorganisms present in the water. Therefore, reductions of pathogens as a result of these processes are largely fortuitous. Furthermore, a given unit process acts differently upon different classes of pathogens, so it is not at all surprising that bacterial indicators of sanitary significance may not be affected in the same way or to the same degree as particular pathogens. Information concerning treatment efficacy can aid in assessing the microbiologic effects of these water treatment processes and in predicting the results of changes that may be contemplated.

No matter how excellent the quality of drinking water may be when the treatment plant is finished, the responsibility of the water utility must extend to safe storage and distribution of the water to the service connection at the point where the water is used. Where proper distribution and storage facilities do not exist, they must be

built. Indeed, the epidemiologic record of disease outbreaks involving public water supplies suggests that recontamination of finished water during distribution is one of the major problems confronting water supplies in all countries. Community distribution systems are inevitably complex and have frequently been constructed in stages over long periods of time, so that construction practices presently regarded as standard may be represented in only a portion of an existing network. Use of substantial volumes of water for firefighting, industrial applications, or the sudden incidence of natural or manmade catastrophe, can disrupt well-considered and established water distribution procedures. Therefore, water distribution systems must be adaptable to a variety of uses, and decisions for new construction must be integrated into the overall land use planning exercise for the community.

Though the principal emphasis in this report has, necessarily, been on the effects of water and of drinking water technology upon microorganisms, it is also obvious that some microorganisms are capable of significant effects upon their immediate environment and that these effects must be considered in discussing water treatment and distribution. Problem areas include the degradation of surfaces in contact with drinking water, as a result of organic or inorganic reactions induced by microbes, and the influence of accumulated microbial cells upon the functions of water treatment resins and on the mains through which water is expected to flow. The technological problems which may result from microbial growth during treatment and distribution of public water supplies are part of the task of providing water to the consumer; however, drinking water, in some situations, must be held in a static condition for substantial periods of time. Two such applications are that of supplying drinking water aboard ships and that of packaging drinking water in containers for emergency use or for commercial distribution. Each of these technological problems may appear to lie outside the traditional scope of drinking water microbiology, but are included because they are significant to the task of providing safe, palatable drinking water to the consuming public.

This report on drinking water microbiology is, as was previously stated, intended to treat the subject as broadly as possible. Although it is clear that there are many problems in water supply which are not of a microbiologic nature,



it must be noted that microbes are probably the oldest form of life and that they almost certainly originated in water. Therefore, the human species, as a late and opportunistic arrival on the face of the earth, must to some degree base its strategies for survival upon understanding and learning to deal with the interactions between microorganisms and water. In this context, we trust that the report which follows will contribute significantly to our collective potential to survive.

LIST OF TABLES

		Pages
A.1-1	Composition of the Hydrosphere and Rate of Turnover . . . . .	8
A.1-2	Content of Bacteria and Organic Matter at Different Soil Depths . . . . .	12
A.1-3	Survival of Bacteria on or in Soil . . . . .	19
A.1-4	Survival of Bacteria in Groundwater . . . . .	21
A.1-5	Movement of Bacteria through Soil . . . . .	22
A.1-6	Median Bacterial Counts (per gram) in Four Replicate Samplings of a Single Site at Various Times after Application of Digested Sludges . . . . .	24
A.1-7	Bacteria in Groundwater beneath Infil- tration Ponds Sampled in January and February of 1977 . . . . .	26
A.1-8	Microbiological Summary of Completed Groundwater Surveys . . . . .	28
A.1-9	Microbiological Requirements for Drink- ing Water in the European Economic Community . . . . .	29
A.2-1	Colony Counts in Four Rivers of Czechoslovakia . . . . .	34
A.2-2	River Water Quality as Determined by Numbers of Chemoorganotrophs at 22°C . . . . .	35
A.2-3	Classification of Chemolithotrophic Bacteria . . . . .	36

LIST OF TABLES -- Continued

	Pages
A.2-4	Proposed Water Quality Criteria to be Used for Raw Surface Water Supplies . . . . . 47
A.3-1	Recorded Waterworks by Population Served . . . . . 52
A.3-2	Recorded Waterworks Serving More than 1,000 People . . . . . 53
A.3-3	Frequency of Bacteriological Analyses of Raw Water at the Recorded Waterworks . . . . . 54
A.3-4	Bacteriological Quality of Surface Water: Total Coliforms . . . . . 56
A.3-5	Bacteriological Quality of Surface Water: Thermo-tolerant Coliforms . . . . . 57
A.3-6	Bacteriological Quality of Ground- water: Total Coliforms . . . . . 58
A.3-7	Bacteriological Quality of Ground- water: Thermo-Tolerant Coliforms . . . . . 59
A.3-8	Bacteriological Quality of Raw Water Receiving Minimum or no Treatment . . . . . 60
B.1.b-1	Human Enteric Viruses that may be Present in Contaminated Water . . . . . 92
B.2-1	Sources of Waterborne Pathogens . . . . . 122
B.3-2	Persistence of Some Enteroviruses in Water . . . . . 134
B.4-1	Median Peroral Infective Dose of Water- borne Pathogens cited in this Section . . . . . 137

LIST OF TABLES -- Continued

	Pages	
B.5.a-1	Waterborne Disease Outbreaks in the U.S., 1971-1975 . . . . .	142
B.5.a-2	Waterborne Outbreaks in the U.S., 1971-1975, by Type of System . . . . .	143
B.5.a-3.	Deficiencies resulting in Outbreaks of Waterborne Disease in U.S. . . . .	145
C.1.a-1	Colony Count Criteria for Various Types of Water in Several European Communities . . . . .	175
C.1.d-1	Thermo-Tolerant Coliform (TTC)/Fecal Streptococcus (FS) Ratios and FS Distributions in Warm-Blooded Animals . . . . .	186
C.2.e-1	Modified Gyllenberg and Niemela Medium Formulation . . . . .	215
C.2.e-2	YN-6 Medium Formulation and Preparation . . . . .	216
C.2.e-3	Groupings of <u>Bifidobacterium</u> Species . . . . .	218
C.2.h-1	Distribution of Aerogenic Versus Anaerogenic Aeromonas in Water . . . . .	229
C.4.e-1	BLB Formulation . . . . .	268
C.4.f-1	M 7-h FC Medium Formulation . . . . .	270
C.4.g-1	Identification and Relative Frequency of Cultures from Raw and Drinking Water Samples . . . . .	276
C.4.h-1	M-SPC Medium Formulation . . . . .	282
D-1	Sampling and Sample Storage, Drinking Water Analysis . . . . .	295A

LIST OF TABLES -- Continued

	Pages
D-2	Total Coliform Testing, Membrane Filter Technique, Drinking Water Analysis . . . 297A
D-3	Total Coliform Testing, Multiple Tube Technique, Drinking Water Analysis . . . . . 306A
D-4	Thermo-tolerant (Fecal) Coliform Testing, Membrane Filter Technique, Drinking Water Analysis . . . . . 314A
D-5	Thermo-tolerant Coliform Testing, Multiple Tube Technique, Drinking Water Analysis . . . . . 319A
D-6	Colony Count, Drinking Water Analysis . . . . 323A
E.Intro-1	Scheme of Treatment for the Preparation of drinking Water . . . . . 330
E.2-1	Removal of Bacteria by Coagulation With Aluminum Sulfate and Sedimentation . . . . . 341
E.2-2	Removal of Enteric Viruses by Coagulation and Sedimentation . . . . . 344
E.2-3	Removal of Parasitic Cysts by Coagulation with Aluminum Sulfate and Sedimentation . . . . 349
E.5.a-1	Lethality Coefficients for Different Microorganisms Based on Treatment with Free and Combined Chlorine at 5°C . . . . . 366
E.5.a-2	Dosages of Various Chlorine Species Required to Inactivate 99% of <u>Escherichia coli</u> and Poliovirus 1 . . . . . 367
E.5.a-3	The Oxidation-Reduction Potential of Chlorine in Water . . . . . 369

LIST OF TABLES -- Continued

	Pages
E.5.b-1	Summary of Data From Studies of Bacterial Inactivation by Ozone in Water . . . 380
E.5.b-2	Summary of Data from Studies of Viral Inactivation by Ozone in Water . . . . . 382
E.6-1	Estimation of the Percentage of Micro- organisms Removed by Various Water Treatment Processes . . . . . 395

LIST OF FIGURES

	Pages
A.1-1	Degradation of Organic Substances in the Presence of Sufficient Amounts of Oxygen . . . . . 15
A.1-2	Degradation of Organic Substances with Insufficient or no Oxygen . . . . . 16
B.1.c-1	Relationship between Cysticidal Residual , Titratable Iodine (I <sub>2</sub> ), and Contact Time at 3°, 10°, 23° and 35°C . . . . . 108
B.1.c-2	Relationship of Contact Time to Concentration of I <sub>2</sub> and HOI for Destruction of 99.9 percent of Cysts, Viruses, and Bacteria at 18°C . . . . . 109
C.4.e-1	Automatic Apparatus for Continuous Testing for <u>E. coli</u> in Water: Schematic Diagram . . . . . 265
C.4.e-2	Sequential Diagram of Introduction of Samples, Culture Medium and Decontaminating Solution A & B: Pneumatic Lifters Alternately Closing Off the Tubes Supplying Culture Medium, Water Sample and Decontaminating Solution . . . . . 266
C.4.g-1	Scheme for Identification of Cultures from P-A Test . . . . . 277
E.5.a-1	Diagrammatic Representation of Completed Breakpoint Reaction for Chlorine. 364
E.5.a-2	Time-Concentration Relationship in Destruction of Cysts of <u>Entamoeba Histolytica</u> by HOCl at 3° and 23°C . . . . . 372

LIST OF FIGURES -- Continued

	Pages
E.5.a-3	Effect of Temperature on Cysticidal Efficiency of $\text{NH}_2\text{Cl}$ and $\text{NHCl}_2$ . . . . . 373
E.5.b-1	Diagrammatic Representation of Completed Breakpoint Reaction Ozone . . . . . 378
G.4.b-1	Cycle of Biological Corrosion . . . . . 446
G.4.b-2	Formation of Different Forms of Iron Deposits in Water Pipes . . . . . 447
G.4.b-3	Schematic Representation of a Section of a So-called Rust Knob . . . . . 448



## A. RAW WATER

The ultimate source of water in various freshwater environments is precipitation, be it rain, snow, or hail. From there, it evaporates, is transpired, runs off directly into streams, rivers, and lakes or it percolates through the soil to travel eventually into groundwater aquifers. As water makes its descent to the ocean, it may pass through both the groundwater state and the surface water state. The increasing demand for potable water to supply domestic and commercial needs has prompted many communities of the world to use new source waters, including those receiving wastewater from homes, communities, and industries (Dykes, et al., 1967).

As a rule any body of fresh water, whether or not it receives wastewater, contains a great number of microbes, among which may be bacteria, algae, protozoa, fungi, and viruses (including phages). Some of these microbes are indigenous to natural bodies of water whereas others are transient, entering the water from air or soil and, more significantly, from domestic or industrial wastewater. The presence, activities, and interactions of both indigenous and transient microbes are extremely important because they may affect the health of humans and other animals. The persistence of these organisms in any given water varies from hours to months and is influenced by a variety of environmental conditions (e.g., available nutrients, pH, temperature, presence of toxic substances, competition, predation, etc.). The complexity with which these factors interact is even greater if the body of receiving water is flowing, as in the case of a river.

Chemolithotrophs, as the name implies, obtain their energy from the oxidation of simple inorganic elements or compounds (i.e., ammonia, sulfur, reduced iron and/or manganese). Thus, all of these organisms play an important role in the cycling of the elements. Chemolithotrophic bacteria are divided into: (1) obligate chemolithotrophs (able to oxidize only certain specific inorganic substances as sources of energy but can derive their carbon from any of several

sources); (2) heterotrophic chemolithotrophs (can utilize several different sources for energy but are wholly restricted to carbon dioxide as their carbon source); and (3) mixotrophic chemolithotrophs (can obtain both energy and carbon from different sources).

The prevalence of chemolithotrophs is influenced by various factors. For example, nitrifiers (members of the family Nitrobacteraceae) are strict aerobes, preferring a pH slightly above 7.01. On the other hand, some sulfur-oxidizers require a pH of 1.0 to 3.5. Whereas the growth of some microorganisms is inhibited by the presence of organic compounds, others are mixotrophic and can function both as chemolithotrophs and as chemoorganotrophs (Alexander, 1971).

Chemolithotrophs play various important ecological roles within source waters. For example, Nitrobacteraceae convert ammonia to nitrite and nitrite to nitrate. Nitrate is a universal nitrogen source for green plants and, when present, stimulates the growth of aquatic weeds which, in turn, may temporarily immobilize the nitrate by removing it from circulation. However, the subsequent death and decomposition of such weeds within source waters result in taste and odor problems along with oxygen depletion.

Sulfur bacteria, such as members of the genus Thiobacillus, are facultative and as such, can thrive in aerobic as well as anaerobic environments [See Section G.4.c] They oxidize both reduced sulfur (such as hydrogen sulfide) and reduced iron (ferrous compounds). Their activities, therefore, are largely beneficial since reduced sulfur compounds (such as hydrogen sulfide) not only impart a distinctive odor to potable water, but may be toxic to animals, given sufficient quantities.

Members of the family Siderocapsaceae can deposit iron and/or manganese oxides on their capsules. Their presence in source water may be beneficial where large amounts of reduced iron and/or manganese (agents responsible for fouling of pipes) are also present and will, as a result, undergo biological oxidation [See Sections F.2 to 3 and G.4.b].

Chemoorganotrophs, more commonly referred to as heterotrophs, obtain energy from the oxidation of organic compounds. They include not only saprophytic, parasitic, and pathogenic bacteria, but also fungi and protozoa.

Whereas human or animal pathogens usually require rich nutrient substrates, aquatic saprophytic bacteria are less fastidious and can thrive in an environment with extremely low nutrient concentrations. They include both gram-negative nonsporeformers (members of the Spirillaceae and Pseudomonadaceae), and gram-positive cocci and endospore-forming bacteria (members of the Micrococcaceae and Bacillaceae). Some are sheathed (members of the genera Sphaerotilus, Leptothrix, Crenothrix, etc.); some possess appendages (Hyphomicrobium, Caulobacter, Gallionella, etc.). Several members of the sheathed and appendaged bacteria are well known among sewage and water treatment operators. For example, species of Gallionella have been responsible for plugging sand filters and other water treatment media [See Sections E.4 and G.2] (Warren, 1971).

Among the myriads of fungi, only a few species thrive to any extent in an aquatic environment. Those classes of fungi most prevalent in the aquatic environment (chytridiomycetes, hypochytridiomycetes, and oomycetes) do not appear to cause disease in man or other mammals (some chytrids may parasitize certain species of algae). However, saprolegnias, notably S. parasitica, have been known to cause a disease of fish and fish eggs and may cause significant economic damage (Alexopoulos, 1962).

Aquatic protozoa ingest minute algae and bacteria in addition to large quantities of organic debris found in their habitat; they are regarded as consumers or grazers. Of the five phyla (Mastigophora, Sarcodina, Ciliata, Cnidospora, and Sporozoa), the first three are thought to be indigenous to unpolluted waters. They play an important role in the aquatic environment as scavengers, but the majority are considered harmless to humans.

The occupancy of different niches, the cycling of elements, and the scavenger activities, all of which support a diversity of life forms and maintain the stability of the source water ecosystem, can be thrown off balance or drastically altered when increased volumes of untreated or inadequately treated wastewater are discharged into source waters (Cairns, 1977).

Most source waters, whether lake, reservoir, river, or groundwater will, at some point, receive wastewater from human activity (Fair and Morrison, 1967). Nearly 200 to 450 l (50 to 100 gal) of wastewater are produced daily per individual in a developed country. These wastewaters are discharged to receiving bodies of water as untreated or

treated effluent. Wastes may be derived from domestic sewage, from agricultural or industrial discharge, from cesspool seepage or leachate, from a refuse disposal site, or from wild animals and birds. The effect of effluent discharge upon the receiving water, expressed in microbiologic terms or as BOD and suspended solids, varies with the kind of wastewater, the treatment it has received, the quantity discharged, and the dynamics of subsequent dilution. Understandably, the BOD or microbial content of wastewaters derived from slaughterhouses and meat packing plants is considerably different from wastewaters of paper manufacture, and these are different from domestic wastewaters (Tabor, 1976).

When large numbers of thermo-tolerant coliforms, fecal streptococci, Clostridium perfringens, Bifidobacterium bifidum, Bacteroides, Veillonella, and Peptostreptococcus are encountered in a source water, they signify fecal pollution [See also Sections C.1.c to e and D.4 to 5]. In addition to human intestinal microbes, wastewater derived from municipal sources may contain all of the indigenous aquatic and soil microflora and -fauna. As a rule, the great majority of microbes derived from wastewaters are harmless chemoorganotrophic saprophytes. However, wastes entering a waterway, whether treated or not, increase the opportunities for contamination with disease agents.

The agents of typhoid fever, bacillary dysentery, and cholera are members of the family Enterobacteriaceae, are associated with wastewater, and are potentially transmissible by contaminated drinking water [See Sections B.1.a(i), (ii), and (vii)]. Outbreaks of gastroenteritis caused by Yersinia enterocolitica [See Section B.1.a(iii)] have been reported, and the organism is apparently more widespread in source waters receiving wastewater than once thought (Highsmith, et al., 1977a). Enteropathogenic or toxigenic strains of Escherichia coli [See Section B.1.a(iv)] also have occurred in source waters. Francisella tularensis (agent of tularemia) [See Section B.1.a.(v)] is another pathogen associated with surface water contamination on rare occasions (Safe Drinking Water Committee, 1977).

Recently, gram-negative, antibiotic-resistant strains of Pseudomonas aeruginosa (cause of melioidosis) have been transmitted to humans via source water receiving wastewater [See Section B.1.a(ix)]. The organisms are well known as pathogens of both animals and plants. Antibiotic-resistant species of Aeromonas (e.g., A. hydrophila) not commonly

identified as agents of human infection (but rather of certain species of fish and frogs) have been transmitted to humans via source waters contaminated by wastewater and have caused cases of acute cellulitis (Hanson, et al., 1977). Populations of this organism in numbers as high as  $10^5$  to  $10^6$  cells per ml have been found in aquatic environments which receive wastewater [See Section C.2.h].

Other bacteria (e.g., Klebsiella pneumoniae, Corynebacterium diphtheriae, Streptococcus pyogenes, S. pneumoniae, and others), whose epidemiologic significance has been traditionally associated with food or air, have been isolated from improperly treated wastewater effluent. Pathogenic members of the orders Actinomycetales, Mycoplasmatales, Rickettsiales, and Chlamydiales might also be transmissible from wastewater to sources of drinking water. Similarly, raw water derived from surface water which receives human or animal waste (either raw sewage or effluent from improperly treated sewage) may be a potential source of the Legionnaires' disease agent, Legionella pneumophila. The agent was thought to be closely associated with water in an air-conditioning system or wind-blown dust from an excavation site close to the outbreak of the disease. However, further investigation revealed that L. pneumophila has been isolated from nonepidemic-related aquatic habitats including streams, lakes, and soil (Fliermans, et al., 1979).

More than 100 different enteric viruses have been isolated from the feces of infected humans in concentrations as high as  $10^6$  plaque-forming units (pfu) per gram. Raw sewage has yielded as many as  $5 \times 10^5$  pfu per liter of enteric viruses (Buras, 1976). Since viruses are not altogether destroyed during wastewater treatment (though the majority will have been removed by coagulation, sedimentation, and filtration procedures) [See Section E], they may enter surface or groundwater via treated waste effluent (Wellings, et al., 1975) and find their way to another community's source water [See Sections B.1.b and B.1.d]. Viruses have been recovered recently from both treated and raw wastewater effluents; from soil receiving digested sludge; from lakes and rivers which receive treated sewage effluent (Gerba, et al., 1975a); and from estuaries in which water salinity may vary from less than 1 percent to 12 percent. Some of the more important viruses which occur in wastewater and other aquatic environments and might be transmitted by contaminated drinking water are enteroviruses, reoviruses, parvoviruses, hepatitis virus type A, adenoviruses, and gastroenteritis viruses [See Sections B.1.b and B.1.d].

Only free-living protozoa may flourish in unpolluted waters, so facultative or obligately parasitic protozoa may be considered as transient populations. Yet, both parasitic and facultatively parasitic protozoa produce cysts and trophozoites in their life cycles. Protozoan cysts are frequently found in human feces and therefore, also in wastewater [See Section B.1.c]. Hence, source waters receiving wastewater discharges may harbor forms of these protozoa. Most cysts resist disinfection by chlorine, bromine, or ozone; but the great majority are apparently removed by coagulation, sedimentation, or subsequent filtration. The majority of waterborne protozoan disease outbreaks in the U.S. have been associated with drinking water derived from surface waters receiving wastewater which was treated only by natural sedimentation and disinfection. More efficient treatment, including coagulation and sedimentation to remove cysts, followed by disinfection, must be used routinely when processing source water receiving wastewater, to avoid epidemics of amoebic dysentery, giardiasis, and meningoencephalitis [See Section E].

There is little information on the habitats of some potentially pathogenic microbes such as Mycoplasma, pathogenic yeasts, and other fungi (Safe Drinking Water Committee, 1977). However, fungi do not appear to be important causes of waterborne disease in man, though they are frequently incriminated as the cause of undesirable tastes and odors.

Certain pathogens are more virulent than others. Though virulence is a genetic trait, it is also related to infectious dosage (the number of pathogenic organisms required to cause infection) [See Section B.4]. For example, ingestion of a relatively small number of Shigella dysenteriae may cause acute disease, whereas exposure to a somewhat larger population of Vibrio cholerae is required to infect a susceptible individual. Pathogens also vary in that: some are able to donate or receive antibiotic resistance; some have traditionally been associated with foodborne or airborne disease; some contain in their cell walls lipid-polysaccharide complexes (endotoxins) that can produce illness; and some propagate or cause illness only under very special conditions [See Sections B and G.2].

Furthermore, there is nothing constant or necessarily predictable about the numbers and kinds of pathogenic microflora and -fauna associated with wastewater effluent. The numbers and kinds vary with the degree of treatment and disinfection, and these factors are subject to daily or even

hourly change. In addition, some pathogens are capable of resisting chlorination, or displaying a phenomenon known as aftergrowth [See Section F.2]; that is, multiplication within the receiving body of water. At one mechanical-biological treatment plant in Denmark, reduction of fecal and pathogenic organisms was found to be 90 to 99 percent, with the exception of Clostridium perfringens [See Section C.1.e], which was reduced by only 63 to 98 percent (Kristensen, 1974). C. perfringens, considered primarily a food-borne pathogen is virtually always present in raw sewage as well as in mechanically and biologically treated sewage effluent. For all of the reasons just mentioned, kinds as well as numbers of pathogens per volume of raw water must be determined before the potential health hazard of any source water can be assessed and the degree of treatment prescribed.

To summarize, microbes within source water that receives wastewater effluents are either indigenous or transient. These microbes include bacteria, algae, fungi, protozoa, and viruses. The bacteria may be further characterized on the basis of modes of obtaining energy, such as phototrophic, chemolithotrophic, and chemoorganotrophic; each set occupies a specialized niche in the aquatic ecosystem.

As is true of organisms indigenous to source water, the majority of microbes derived from wastewater are harmless saprophytes. However, as greater quantities and more diversified qualities of wastes are discharged to source waters, pathogens, whether obligate or opportunistic, are more likely to be present. Hence, it is the degree to which raw waters are contaminated with waste that determines, in large measure, the risk involved in producing finished water that is free of disease agents.

## 1. Microbiology of Groundwater

Historically, groundwater has been a source of relatively clean, high quality drinking water, needing little, if any, treatment. In contrast, surface water almost always has required some level of treatment as a result of ever increasing human interactions, in the form of industry, agriculture, aquaculture, recreation, sewage disposal, and other activities, with the hydrologic cycle. In many countries, pollution of surface waters has led to a decrease in their suitability for potable use or rendered them more costly and complicated to treat. The relative purity of groundwater has led to greater world reliance on this source for supplying potable water. On a global scale, groundwater sources appear to be much more plentiful than surface water sources [See Table A.1-1].

TABLE A.1-1

COMPOSITION OF THE HYDROSPHERE  
AND RATE OF TURNOVER

Parts of the Hydrosphere	Volume <sup>a</sup> in Thousands of Cubic Kilometers	Rate of Water Turnover (Years)
World oceans	1,370,000	3,000
Groundwater	60,000	5,000 <sup>b</sup>
(groundwater -- zones of active turnover)	4,000	330 <sup>c</sup>
Polar ice caps	24,000	8,000
Surface water	280	7
Rivers	1.2	0.031
Soil moisture	80	1
Atmospheric vapor	14	0.027
Total hydrosphere	<u>1,454,000</u>	<u>2,800</u>

From Ilvovitch, 1977.

<sup>a</sup>In round numbers.

<sup>b</sup>Includes groundwater runoff to oceans bypassing rivers -- 4,200 years.

<sup>c</sup>Includes groundwater runoff to oceans bypassing rivers -- 280 years.



About 98 percent of Denmark's population obtains its drinking water from minimally treated or untreated groundwater. In the U.S., over 50 percent of the population receives its drinking water from groundwater sources, roughly half of which have been treated minimally or not at all. However, between 1946 and 1974, over 50 percent of all waterborne disease outbreaks in the U.S. were attributed to contaminated groundwater (Allen and Geldreich, 1975). One of the most important diseases spread via groundwater is hepatitis A [See Section B.1.b]. In a review of 48 hepatitis outbreaks occurring worldwide and involving 31,357 people, groundwater was implicated in 21 of these and involved 1,378 people (Taylor, et al., 1966).

Recent trends in land disposal of sewage effluent and sludge have prompted scientists and hygienists to examine possible new and adverse chemical and microbiological effects upon groundwater. Manure has been used extensively in agriculture for hundreds of years without any reported disease outbreaks resulting (except where excessive fertilization or cattle feedlot impoundments led to nitrate contamination). However, lately, many new methods have been used to dispose of wastes on land, which has consequently increased the volumes disposed there. Moreover, as sewage treatment methods improve, production of sludges will increase, resulting in greater impacts to the land and to aquifers below. The growing practice of groundwater recharge with wastewater is also of concern.

Volumes of wastewater produced in the year 2000 are expected to be ten to 15 times higher than those produced in 1970 (Ilvovitch, 1977). It therefore would appear that we are dealing with problems whose solutions will become increasingly urgent in the next few decades. The protection of our groundwater resources will become more important as our reliance on land disposal of wastes increases as an alternative to discharging them into surface water.

a. Definition of Groundwater. Water resources differ from other natural resources in that the hydrologic cycle and hydrosphere are two inextricably bound systems with one constantly exerting an influence over the other. Taking part in this cyclic continuum are oceans, ice caps and glaciers, lakes, streams, groundwater, and the atmosphere. Surface water and groundwater are in contact through river and lake beds. Most precipitation evaporates and returns to the atmosphere; a lesser portion returns to the sea through

streams and rivers; and only a minor part sinks into the ground and percolates through the soil system to become groundwater.

That water which percolates through the soil and stops its downward movement upon reaching an impermeable layer comprises the groundwater. Water in this zone fills the soil pores and flows horizontally. Because it has passed through the soil system, where processes such as ion exchange, adsorption, precipitation, and chemical alterations including biodegradation take place, groundwater will differ both chemically and microbiologically from surface water.

Above the groundwater is an unsaturated zone where water percolates both horizontally and vertically while some of it remains there held by adhesion and capillarity. It is in this unsaturated stratum that various physical, chemical, and biological activities take place which normally will determine groundwater quality. Climate, the depth and geochemistry of the unsaturated zone, and activities at the surface (such as waste disposal) are all major factors affecting groundwater quality.

Normally, groundwater is virtually free of organisms because they are filtered out or adsorbed to particles in the soil system. If there is sufficient soil depth, texture, structure, and biological activity, the groundwater should be of acceptable microbiological quality. On the other hand, more than 40 groundwater samples from deep aquifers in Jordan were found to contain coliforms; this was attributed to poor filtration of the overlying soil (Shehabi, 1976). The rate of groundwater turnover is much slower than that of surface water [See Table A.1-1] and therefore, once groundwater has become contaminated, it remains contaminated much longer. For this reason, the issue of waste disposal on land becomes that much more serious.

This groundwater discussion pertained to that which occurs in deep aquifers and did not take into account well water which may become contaminated with surface water when leaky covers are situated below surface level, or as a result of improper construction or placement.

b. Occurrence of Indigenous Microorganisms in Groundwater. Groundwater usually is extremely low in organic matter (or that which is present is in an unavailable form), and this combined with filtration in the unsaturated zone normally

precludes the presence of any organisms except possibly a few chemolithotrophic bacteria. These bacteria usually range in numbers between 20 and 50 per ml (Hvid, 1955). The ratio of chemoorganotrophs (also called chemoheterotrophs) to chemolithotrophs is a function of the organic content of the soil, which decrease with depth [See Table A.1-2]. The total numbers of microorganisms decrease with the depth of the soil, but below one meter, both the amount of organic matter and numbers of chemoorganotrophs are low while the proportion made up of chemolithotrophs rises. Samples taken from deep borings may be sterile or contain only chemolithotrophic bacteria, such as methane, sulfur, and/or iron bacteria.

The presence of methane in groundwater indicates activity of methane-generating bacteria such as Methanobacterium, which reduce carbon dioxide and organic acids to methane. Such bacteria may cause problems because methane is a nutrient source for certain slime bacteria which may grow in layers on filters, along pipes, and in containers (Völker, et al., 1977) [See Sections G.2 and F.3]. Sulfates, if present in groundwater, may be reduced to hydrogen sulfide by bacteria such as Desulfovibrio and thereby render the water unacceptable for potable use [See Sections F.2.d and G.4].

Iron and manganese bacteria, including the Sphaerotilus-Leptothrix group and Gallionella, may be present in groundwater. These bacteria obtain energy by oxidation of ferrous and bivalent manganese compounds [See Section G.4]. Hydrogenomonas, which can oxidize molecular hydrogen to obtain energy, has also been recovered from aquifers (Hvid, 1955).

Samples taken from deep borings normally contain few, if any, chemoorganotrophic bacteria unless there has been some mixing with surface water resulting in availability of organic material. Danish investigators found anaerobic actinomycetes, clostridia, and anaerobic gram-positive non-motile cocci (unclear taxonomy) in samples from deep borings (Hvid, 1955). These cocci and actinomycetes are important in denitrification of nitrates in the unsaturated zone and as such, are instrumental in preventing occurrence of nitrates in groundwater. Also found within the groundwater in Denmark were nonsporeforming, motile, gram-negative, glucose-negative, and gelatin-positive bacteria (possibly belonging to the genus Vibrio) (Bonde, personal communication). Such bacteria may not always be detected by conventional methods and may propagate in slow moving or stagnant parts of the distribution system [See Section F.2].

TABLE A.1-2

CONTENT OF BACTERIA AND ORGANIC MATTER  
AT DIFFERENT SOIL DEPTHS

Depth (cm)	Organic Matter (%)	Million Bacteria per Gram	
		Aerobes	Anaerobes
0-6	8.04	49.2	1.0
6-12	3.18	131.8	1.0
12-28	2.41	158.3	10.0
28-48	1.76	45.3	1.0
48-80	0.80	6.0	0.001

From Jepsen, 1972.

Bacteria also can propagate in water of initial potable quality that has been stored. Investigators in Norway stored groundwater with a potassium permanganate value of 1.5 at 22°C for 3 to 13 days, after which time original bacterial numerals of 2 per ml had swelled to over 100,000 per ml. However, such marginal levels of organic matter content would be highly selective for the less fastidious bacteria [See Section G.6].

Although fungi (of which about 200 genera have been isolated from soil) are more prevalent than bacteria in soil, very little is known about their presence in groundwater. Fungi, pathogenic to humans, also may occur in soil. All fungi are aerophilic and do not grow under strict anaerobic conditions such as would occur in water-logged soil.

Protozoa, including flagellates, amoebae, and ciliates, may appear in the upper part of the unsaturated zone in numbers varying from  $10^3$  to  $10^6$  per gram of soil. However, owing to their size, they are readily entrapped within the soil matrix and prevented from entering groundwater.

c. Fate of Organic Substances in Groundwater. As a rule, undisturbed groundwater bears organisms and chemicals indigenous to that environment. But, accompanying the rapid increases in human populations have been more intense and varied uses of land and water. This has meant, in some instances, that groundwater may be derived in part from water percolated from surfaces to which treated or untreated sewage effluents have been applied. Or, it has led to the practice of disposing sewage effluent or sludge on land near sources of groundwater used in producing potable water. The extent to which these practices pose a threat to the safety of groundwater depends on the types and quantities of waste applied and on the climate and hydrogeology of the site.

Pollutants may enter the aquifer directly through crevices and fractures in the bedrock or through porous subsoil. They may percolate through shallow soils, or enter the aquifer during bank infiltration practices used in some areas for treating surface waters (Federal Ministry of the Interior, 1975) [See Section E.4]. Pollutants also may enter groundwater via deep injection wells used for underground storage or disposal of industrial or municipal wastewater or of septage. Toxic or obnoxious pollutants may enter the aquifer as a result of accidental spills during transport (Federal Ministry of Health, 1969); such events

can no longer be considered extremely rare. Once these substances enter groundwater, they may travel great distances and pollute uncontaminated water in nearby aquifers.

The fate of organic substances in groundwater depends largely on the presence of saprophytic microbes and on the availability of dissolved oxygen. Organic substances, when in the presence of sufficient available oxygen, may be oxidized or mineralized to such products as carbon dioxide, nitrate, and sulfate [See Figure A.1-1]. However, any aerobic biooxidation of organic substances in an environment such as an aquifer almost always depletes the supply of dissolved oxygen, thereby decreasing the oxidation-reduction potential of the water. Such conditions favor the microbial reduction of certain substances (e.g., ferric and tetravalent manganese ions, nitrate, sulfate, etc.) to a number of unacceptable products including ferrous and manganous ions, ammonium, nitrite, methane, hydrogen sulfide, and other reduced sulfur compounds (Schweisfurth and Ruf, 1976) [See Figure A.1-2]. These biogeochemical conversions are known to occur even in aquifers deep underground.

Reduced inorganic or organic substances in groundwater subsequently may be spontaneously (chemically) or microbially oxidized when the water is brought to the surface to be processed through a water treatment facility, for example. Here, various microorganisms such as species of Sphaerotilus, Leptothrix, Phragmidiothrix, Gallionella, and especially Crenothrix polyspora (Schweisfurth, 1974; Völker, et al., 1977) proliferate, producing abundant sheaths or slimes which may be encrusted with oxidized minerals. Sheaths and slimes not only discolor and impart tastes and odors to the water, but also cause considerable problems in treatment since they (especially slimes encrusted with iron or manganese) may plug sand filters and otherwise interfere with the treatment and distribution of drinking water [See Section E.4 and G.2 to 4].

d. New Trends in the Disposal of Sludge and Sewage Effluent. Opportunities for contamination of groundwater, including water in wells, seem to be tied closely to new trends in land disposal techniques. Increasing populations produce more wastes and at the same time withdraw more water for domestic, agricultural, and industrial purposes. As a result, more water is being converted to wastewater, only to be re-introduced into the hydrologic cycle where some will invariably end up as groundwater.

FIGURE A.1-1

DEGRADATION OF ORGANIC SUBSTANCES IN THE PRESENCE  
OF SUFFICIENT AMOUNTS OF OXYGEN

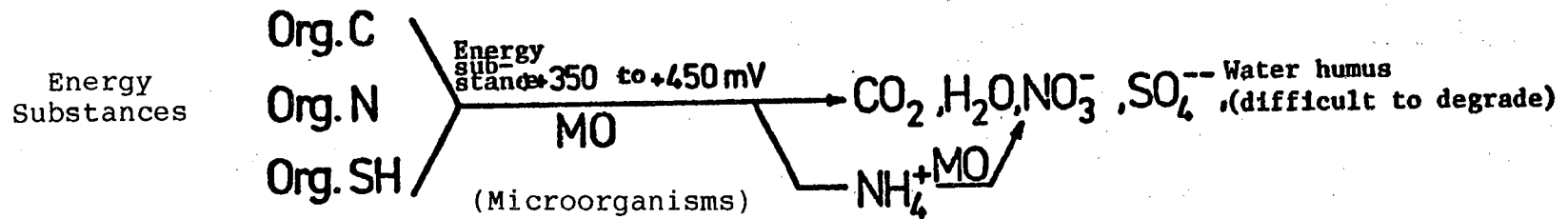

Water after mineralization low in microorganisms.

FIGURE A.1-2

DEGRADATION OF ORGANIC SUBSTANCES WITH INSUFFICIENT OR NO OXYGEN

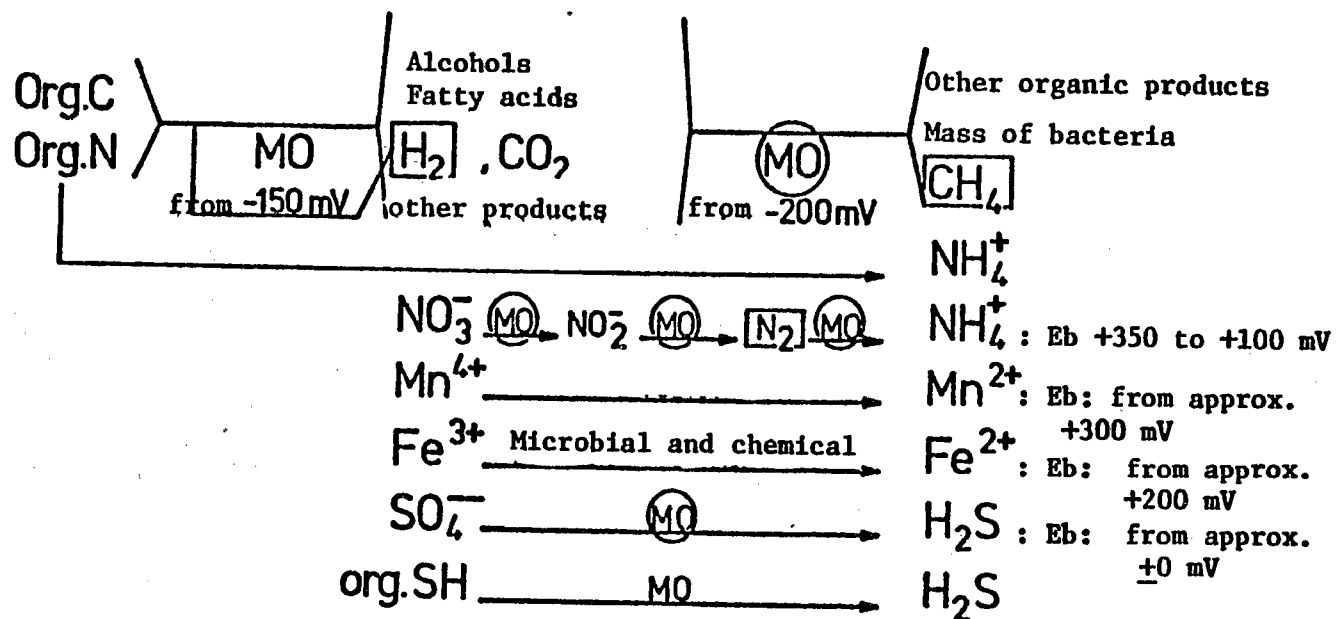

Note.: MO=microorganisms      ○: determined in the laboratory culture  
 □=chemically determined



Hazards associated with septic tank systems, cesspools, and leaky sewage pipes have been known for a long time. Sewerage systems may lose influent to the surrounding soil; and, in fact, it is estimated that the wastewater arriving at the treatment plant is generally 20 percent to 60 percent lower than the amount originally supplied to the municipal system (Shuval, 1977). The reverse (infiltration) also has been known to occur with some regularity. Home septic systems that incorporate a sand-filled seepage pit or leach field for adsorption can be very effective in removing pathogens from the septic tank effluent; yet, many of these individual systems are poorly constructed, receive little maintenance, and become overloaded by the householder so that the domestic sewage essentially bypasses treatment. The potential hazard therefore is that poor quality sewage effluent may seep into groundwater supplies of the home or community.

Sewage effluent disposal to the land has, in recent years, been largely in the form of irrigation, wastewater treatment lagoons, infiltration ponds, and wastewater disposal in underground pits (Cleary and Warner, 1970). Volumes of irrigation water used in some countries are expected to double in the next 20 to 25 years. Such activities may modify water circulation patterns, soil ecology, and ultimately, groundwater quality. Heavy irrigation may cause stronger vertical seepage through soil increasing the potential for groundwater contamination (Kovacs, 1977).

Infiltration ponds are designed for disposal of sewage, but often are used for groundwater recharge besides. However, they should be viewed as waste treatment processes only, since seepage of pollutants to groundwater is a definite possibility, depending on geochemical conditions, climate, level of the water table, and infiltration rate of the wastewater (which can be rather high in some cases). Danish investigators found that the infiltration rate varied between 0.18 m per day during the first year to 0.05 m per day after a few years (Bonde, et al., in press).

The use of treatment lagoons is common, especially in semi-arid regions. Lagoons may be used in conjunction with conventional primary or secondary treatment, but may also be used exclusively to dispose of waste by evaporation, seepage, and direct re-use through irrigation (Klock, 1971).

In areas with a high water table and a low adsorption capacity of the unsaturated zone, the use of wastewater treatment lagoons or infiltration ponds may result in contamination of groundwater with fecal (including pathogenic)

and soil organisms. Moreover, where a sewage stabilization pond has been placed improperly over river alluvium or limestone sink holes, leakages into groundwater or an entire collapse of the pond is possible.

Alterations in the ecology of the soil and groundwater are possible with increased reliance on wastewater treatment lagoons and infiltration ponds. Such changes as the appearance of large numbers of iron and sulfur bacteria in aquifers have already been noted. More important are the potentials for changes in survival, propagation, and movement of pathogens. If pathogens survive longer in soil than the time it takes to pass from a treatment lagoon through the unsaturated zone, these organisms may gain entry into the groundwater. Creation of a new set of variables within soil and groundwater from new waste disposal technologies may change conditions enough that the previously applied principles will no longer hold true. Therefore, it is essential that more be known about factors affecting survival of intestinal microorganisms in soil and groundwater as compared to their survival in treatment lagoons and infiltration ponds.

e. Factors Affecting Survival in Soil and Groundwater. Survival of pathogens in soil and water is determined largely by: (1) species of microorganisms; (2) temperature; (3) sunlight; (4) rainfall; (5) pH; (6) soil type; (7) moisture and organic content of the soil; (8) microbial antagonisms (including production of antibiotics such as actinomycin and streptomycin), predation, and parasitism (bacteriophages); and (9) infiltration rates. Different organisms exhibit different survival rates in soil and water [See Tables A.1-3 to 5]. For example, mycobacteria and sporeformers survive longer than thermo-tolerant coliforms in soil. Climate also is a major factor in that survival is generally greater in winter than in summer [See Table A.1-3], and contamination of groundwater is much more likely during periods of heavy rainfall. Microbial antagonisms (especially from actinomycetes) are very important in the reduction of pathogenic bacteria, but appear not to be with viruses (Gerba, 1974).

Organisms at the soil surface are exposed to UV and desiccation and therefore are less likely to survive than those within moist soil. Less than 15 percent humidity greatly reduces virus numbers (Moore, et al., 1976). In general, bacteria survive longer in alkaline (limestone) than in acid (peat) soils. Irrigation with sewage effluent

TABLE A.1-3

## SURVIVAL OF BACTERIA ON OR IN SOIL

Organism	Soil Type	Time of Year	Survival Time (Days)
Total coliforms	Surface soil	-	38
<u>Escherichia coli</u>	Coarse loam (rich in organic material)	Winter	40 - 65
<u>Escherichia coli</u>	Coarse loam (rich in organic material)	Summer	15 - 30
<u>Escherichia coli</u>	Coarse loam (rich in organic material)	Autumn	13.4 (90% reduction)
<u>Escherichia coli</u>	Coarse loam (rich in organic material)	Summer	3.3 (90% reduction)
Fecal streptococci	Coarse loam (rich in organic material)	Winter	20.1 (90% reduction)
Fecal streptococci	Coarse loam (rich in organic material)	Summer	2.7 (90% reduction)
<u>Streptococcus</u> sp.	Clay loam	-	63
<u>Streptococcus</u> sp.	Clay loam	-	49
<u>Streptococcus</u> sp.	Sandy	-	35

TABLE A.1-3 -- Continued

Organism	Soil Type	Time of Year	Survival Time (Days)
<u>Salmonella</u> sp.	-	-	280
<u>Salmonella</u> sp.	Non-sterile soil	-	100
<u>Salmonella</u> sp.	Surface soil	-	40
<u>Salmonella typhi</u>	Sterile soil	-	216
<u>Salmonella typhi</u>	-	-	60 - 70
<u>Salmonella typhi</u>	Garden soil	November	58
<u>Salmonella typhi</u>	Garden soil	October	50
<u>Salmonella typhi</u>	Sandy soil	October	36
<u>Salmonella typhi</u>	Sandy soil	October	29
<u>Salmonella typhi</u>	Loam (wet weather)	-	25 (90% reduction)
<u>Salmonella typhi</u>	Loam (dry weather)	-	5 (90% reduction)
<u>Brucella abortus</u>	Soil	Winter	125
<u>Mycobacterium bovis</u>	Soil	-	178
<u>Mycobacterium bovis</u>	Surface garden soil	-	8 - 11 (90% reduction)

TABLE A.1-4

## SURVIVAL OF BACTERIA IN GROUNDWATER

Organism	Medium	Survival Time
<u>Escherichia coli</u>	Groundwater held in the laboratory	4 - 4.5 months
<u>Escherichia coli</u>	Groundwater in the field	3 - 3.5 months
<u>Escherichia coli</u>	Recharge well	63 days
Total coliforms	Well water	17 h (50% reduction)
<u>Salmonella</u>	Water infiltrating sand columns	44 days
<u>Shigella</u>	Water infiltrating sand columns	24 days
<u>Shigella flexneri</u>	Well water	26.8 h (50% reduction)
<u>Vibrio cholerae</u>	Well water	7.2 h (50% reduction)

From Gerba, et. al., 1975b.

TABLE A.1-5

## MOVEMENT OF BACTERIA THROUGH SOIL

Organism	Medium	Nature of Pollution	Maximum Observed Distance Travelled (in Meters)	Time of Travel (Hours)
Total coliforms	Sandy gravel	Secondary sewage	0.9	-
Total coliforms	Sand and pea gravel	Diluted settled sewage (into injection well)	31	35
Total coliforms	Sand and gravel mix	Oxidation pond effluent	830	-
Total coliforms	Fine to medium sand	Tertiary treated wastewater	6.1	-
Total coliforms	Fine-grained sand	Sewage introduced through a perforated pipe	1.8	-
Total coliforms	Fine sandy loam	Primary and treated sewage effluent	0.6-4.0	-
Thermo-tolerant coliforms and <u>Streptococcus</u> sp.	Coarse gravel	Tertiary treated wastewater	460	48
Thermo-tolerant coliforms	Fine loamy sand to gravel	Secondary sewage effluent on percolation beds	9.2	-
<u>Escherichia coli</u>	Sand dunes	Canal water on percolation beds	3.1	-

From Gerba, et al., 1975b.

on soil and plant surfaces allows for direct exposure of accompanying flora to UV light and for desiccation between irrigation periods. Death rates under such conditions are relatively high. Waste stabilization ponds, on the other hand, protect microorganisms against exposure to UV and so increase the likelihood of survival. The presence of organic compounds also seems to increase survival of microorganisms. For example, the data in Table A.1-6 suggest that indicator bacteria survive for extended periods in soil to which digested sludge has been applied.

Adsorption of viruses is influenced mainly by pH, the type and concentration of cations, organic matter, and the surface area of the soil particles. Clay soils or, to a somewhat lesser extent, consolidated sands facilitate virus adsorption. The efficiency of adsorption increases the more acid the soil is or the greater the ionic strength is in the suspending medium (obtained, for example, by adding calcium chloride to the soil). Adsorption may be hindered or the process reversed with high concentrations of organic matter. Sites consisting largely of highly fractured rock or mixtures of gravel and sand are unacceptable for waste disposal because viruses and other microorganisms may be transported over long distances in such soils [See Table A.1-5].

In experiments using 250-cm columns of calcareous sand, Lance and coworkers (1976) showed that reductions in the ionic strength of the soil solution, from flooding with deionized water, caused desorption and movement of viruses through the soil (Lance, et al., 1976). However, most viruses were re-adsorbed, and showed a peak concentration at a depth of 10 cm, after flooding with sewage. It is evident, from these and other data, that the best results are achieved by alternating applications of sludge or sewage effluent with dry periods and by avoiding disposal of wastes during periods of heavy rain. If done correctly and at the appropriate site, land application of municipal wastewater or sludge can be a highly satisfactory method of waste treatment.

Once they have entered the groundwater, bacteria no longer have to contend with UV light or microbial antagonisms and this, along with low temperatures of groundwater, prolongs survival (E. coli has been found to survive up to 100 days in subsoil water: Gerba, et al., 1975) [See Table A.1-4]. When sewage effluent was pumped directly into aquifers, fecal streptococci and thermo-tolerant coliforms were recovered at a distance of 33 m (Reviewed by Jepsen, 1972). Viruses, as well, persist longer in groundwater

TABLE A.1-6

MEDIAN BACTERIAL COUNTS (PER GRAM) IN FOUR  
 REPLICATE SAMPLINGS OF A SINGLE SITE AT VARIOUS TIMES  
 AFTER APPLICATION OF DIGESTED SLUDGES

Days After Application of Sludge	Soil			Grass		
	<u>E. Coli</u> <sup>a</sup>	Total Coliforms	Fecal Streptococci	<u>E. Coli</u> <sup>a</sup>	Total Coliforms	Fecal Streptococci
15	250	770	17	689	4,720	0.8
22	4,602	1,774	20	464	> 1,415	1.3
29	8,550	950	23	12	144	1
36	1,200	1,225	250	32	175	< 0.2

<sup>a</sup>Escherichia coli.

From Carrington, in press.



which is clean compared to river or seawater where viral reductions are greater [See Section B.3]. Investigators recovered hepatitis A virus from a well situated 23 m (75 ft) away from a cesspool (Neefe and Stokes, 1945).

From tests made of treatment lagoons (Klock, 1971), it appeared that after about one week (a shorter time during the summer), only 1 percent of coliforms had survived; and only about .001 percent were viable after two weeks (Klock, 1971). Survival rates in infiltration ponds probably are the same. From this, one could surmise that a large majority of pathogens would be eliminated before reaching the soil. Nevertheless, when soil beneath infiltration ponds became saturated with sewage effluent, thermo-tolerant coliforms were recovered at a depth of four, but not eight, meters (Baars, 1957). Since infiltration ponds often are placed in areas of sandy soil, movement of organisms tends to be a problem.

By studying a sedimentation-infiltration pond system in operation for about ten years, researchers in Denmark were able to evaluate long-term consequences to underlying soil and groundwater (Bonde, *et al.*, in press) [See Table A.1-7]. The system consists of two sedimentation ponds and four infiltration ponds receiving raw sewage on an infiltration surface equalling 10 m<sup>2</sup> per capita waste output. The depth to groundwater in the area is about 2 m and the soil is characterized as sandy. Average retention times were eight days in the sedimentation ponds and five days in the infiltration ponds. As can be seen in Table A.1-7, thermo-tolerant coliforms were isolated from all samples collected at a depth of 16.5 m beneath infiltration ponds. Colony counts at 20 and 37°C were quite high at all depths and the presence of *P. aeruginosa* in nearly all groundwater samples indicates probable occurrence of pathogenic bacteria in groundwater below these infiltration ponds.

f. Occurrence of Endotoxins in Groundwater. Gram-positive bacteria are the predominant bacterial microflora of soil, whereas gram-negative bacteria normally predominate in water. Irrigation and disposal of sewage water on soil consistently contribute enormous numbers of gram-negative bacteria, many of which are subsequently eliminated by antagonisms in the soil.

The confrontation in soil between the indigenous gram-positive soil bacteria and the gram-negative water bacteria may result in the release of endotoxins, which are produced

TABLE A.1-7

BACTERIA IN GROUNDWATER BENEATH INFILTRATION PONDS  
SAMPLED IN JANUARY AND FEBRUARY OF 1977

BACTERIA	DEPTH (in meters)				
	1.9	2.5	4.5	9.5	16.5
Total coliforms	$5.4 \times 10^3 - 2.2 \times 10^4$ <sup>a</sup>	$>1.6 \times 10^3 - 1.6 \times 10^5$	$>1.6 \times 10^3 - 1.7 \times 10^4$	$>1.6 \times 10^3 - 1.6 \times 10^4$	$2.3 \times 10^1 - 2.5 \times 10^2$
Thermo-tolerant coliforms	$3.5 \times 10^3 - 2.2 \times 10^4$	$>1.6 \times 10^3 - 5.4 \times 10^4$	$>1.6 \times 10^3 - 1.1 \times 10^4$	$>1.6 \times 10^3 - 1.6 \times 10^4$	$8 \times 10^0 - 4.3 \times 10^1$
Colony counts at 20°C	$2.2 \times 10^8 - 12.9 \times 10^8$	$1.8 \times 10^8 - 13.2 \times 10^8$	$5.0 \times 10^7 - 4.1 \times 10^8$	$1.3 \times 10^7 - 4.7 \times 10^8$	$4.0 \times 10^6 - 4.0 \times 10^7$
Colony counts at 37°C	$6.0 \times 10^6 - 4.4 \times 10^8$	$1.0 \times 10^7 - 4.5 \times 10^8$	$9.0 \times 10^6 - 1.3 \times 10^8$	$4.0 \times 10^6 - 9.6 \times 10^7$	$1.0 \times 10^6 - 4.6 \times 10^7$
Fecal streptococci	$1.8 \times 10^3 - 4.6 \times 10^3$	$5.4 \times 10^2 - 3.9 \times 10^4$	$3.6 \times 10^2 - 4.8 \times 10^3$	$1.0 \times 10^2 - 5.9 \times 10^2$	$1.0 \times 10^0 - 1.0 \times 10^1$
<u>Clostridium perfringens</u>	$1.0 \times 10^2 - 3.0 \times 10^2$	$1.4 \times 10^3 - 1.7 \times 10^3$	$4.0 \times 10^1 - 9.1 \times 10^2$	$\leq 200$	$\leq 100$
<u>Pseudomonas aeruginosa</u>	+ <sup>b</sup>	+	+	+	-
Coliphages	$2.0 \times 10^1 - 3.5 \times 10^2$	$2.0 \times 10^1 - 5.4 \times 10^2$	$1.0 \times 10^1 - 9.2 \times 10^2$	$8.0 \times 10^0 - 5.0 \times 10^1$	$\leq 5.0$

<sup>a</sup>Bacteria per 100 ml.

<sup>b</sup>+ = Pseudomonas aeruginosa present.

(BONDE, ET AL., IN PRESS)

only by gram-negative bacteria. Endotoxins may then travel from the unsaturated zone in the soil into the groundwater. Groundwater situated beneath infiltration ponds in Denmark and sampled at depths of from 1.9 to 16.5 m was found to contain endotoxins in amounts varying from  $10^{-4}$  to  $10^{-6}$  g per ml (Kristensen, 1978). Maximum endotoxin concentrations found during this study were over 10,000 times the minimum dose (2 ug endotoxin per kg body weight) needed to produce clinically measurable effects by parenteral injection in humans (Mikkelsen, 1977). Since they are toxic only if they enter the bloodstream, endotoxins in potable water pose special problems for production of solutions for infusion [See also Sections B.1.a(ix) and C.3.a].

g. Criteria for Evaluating Groundwater Quality.

Groundwater supplies often are tested by the same microbiological criteria used for potable water (Allen and Geldreich, 1975). Though there are differences from country to country, most include tests for total and thermo-tolerant coliforms and colony counts at 21 and 37°C [See Sections C.1.a-c and D]. Tests made in the U.S. have demonstrated the presence of total and even thermo-tolerant coliforms in some community groundwater supplies [See Table A.1-8]. Yet, the apparent absence of coliforms does not necessarily ensure that pathogens, such as *P. aeruginosa* [See Sections B.1.a(ix) and F.3.b] and *Y. enterocolitica* [See Section B.1.a(iii)] are not present in the groundwater (Nemedi and Lanyi, 1971; Lassen, 1972).

There is very little information available on the spread of viruses in groundwater primarily because the most important groundwater-borne virus, the hepatitis A virus, cannot as yet be cultured in the laboratory and remains extremely difficult to study [See Section III.B.1.b]. Virus criteria for drinking water normally are not specified for routine drinking water analyses. Although, in a preliminary proposal submitted by the Commission of the European Communities in 1974, recommendations included a statement that enteroviruses should be absent in 10 l of drinking water, this was removed from the final Council Directive (Commission of the European Communities, 1975) [See Table A.1-9 and Section C.2.b]. It has been suggested that bacteriophages be used as an indicator of enteroviruses [See Section C.2.a]; but Gerba and coworkers (1974) state that removal of bacteriophages during percolation through soil is much greater than removal of enteroviruses.

Before improved indicator systems for assessing groundwater quality can be designed however, more needs to be

TABLE A.1-8

## MICROBIOLOGICAL SUMMARY OF COMPLETED GROUNDWATER SURVEYS

Survey	Number of Samples	Samples (+) for Total Coliforms <sup>a</sup> (%)	Samples (+) for Thermo-Tolerant Coliforms (%)
Community water supply study	621	9.0	2.0
Tennessee-Georgia rural water supplies	1,257	51.4	27.0
Interstate highway drinking water systems	241	15.4	2.9
Umatilla Indian Reservation	498	35.9	9.0

<sup>a</sup>  $\geq$  1 organism per 100 ml.

From Allen and Geldreich, 1975.

TABLE A.1-9

MICROBIOLOGICAL REQUIREMENTS FOR DRINKING WATER  
IN THE EUROPEAN ECONOMIC COMMUNITY

Parameter	Volume of Sample (ml)	Guide Level (GL) Plate Count Agar	Maximum Admissible Concentration (MAC)		Multiple Tube Method
			Plate Count Agar	Membrane Method	
Total coliforms	100	-		0	MPN < 1
Thermo-tolerant coliforms	100	-		0	MPN < 1
Fecal streptococci	100	-		0	MPN < 1
<u>Clostridium</u> sp.	20	-		-	MPN < 1
Colony count (for water supplied for direct consumption)	1	10 (37°C) <sup>a</sup> 100 (22°C) <sup>a</sup>	-	-	

<sup>a</sup>Values for disinfected water should be considerably lower at the point where it leaves the processing plant.

Footnote: In addition to the above analyses, microbiologic examinations should, in cases where warranted, include tests for Salmonella, enteroviruses, and coliphages. All finished water should be free of algae and parasitic protozoa and helminths.

known about soil-groundwater ecology and survival and movement of enteric organisms released to the soil via current waste disposal practices. Whether or not to establish quality criteria for chemolithotrophic bacteria is another matter to be considered. Chemolithotrophs, though not indicators of fecal contamination, are an important cause of operational difficulties at the treatment plant and in the distribution network.

h. Protection of Groundwater. In an effort to divert some of the tremendous volumes of wastewater from discharging into rivers and lakes, many countries are turning to land disposal. At the same time, it is estimated that groundwater will, in the future, satisfy over 50 percent of drinking water needs (Ilvovitch, 1977). Although the soil acts as a buffer against groundwater contamination, just how far this protection can be counted on is not known given these new and intensified circumstances.

Recommendations for protecting groundwater, submitted by the Commission of the European Communities (1979), make a distinction between pollution that occurs in the saturated zone and pollution that occurs in the unsaturated zone. Unfortunately, the proposed measures deal only with chemical and toxicological problems even though over 99 percent of outbreaks of waterborne disease are caused by microorganisms. Whereas it has been shown that groundwater beneath infiltration ponds need only be diluted less than 100-fold to fulfill chemical requirements (e.g.,  $\text{NH}_4^+$ -N and anionic detergents) for drinking water, it must be diluted several thousand fold to satisfy microbiological requirements.

Legislation enacted in Denmark for the protection of groundwater requires that a license be obtained prior to land disposal and specifies conditions under which land disposal of wastes may be considered. Containers whose contents could be construed as potentially contaminating cannot be placed in the soil. Seepage drains and cesspools must be at least 2.5 m above the water table; and wastewater percolation facilities must be no less than 300 m from the nearest water catchment. Pollutants in all such wastewaters must be easily biodegradable. It is recommended that, for municipal sewage effluent, the equivalent of one person's daily waste output be applied to 100 to 400  $\text{m}^2$  of farmland. One hectare is required for one day's disposal of 10  $\text{m}^3$  of dairy wastewater.

High groundwater quality is best maintained by intelligent preventative measures aimed at protecting the integrity of the soil-aquifer ecosystem. Primary treatment with disinfectants such as chlorine does not serve as an adequate substitute but rather, renders more complex the economic and technical props needed to produce a potable product.

i. Conclusion and Recommendations. Pollution of our groundwater supplies is one of the most serious problems confronting the 20th Century. In order to devise and implement means for safeguarding this resource, we need to know a great deal more about long-term effects to soil and aquifers from inundations with wastes. Besides studying altered conditions for survival, propagation, and transport of pathogens, water microbiologists should pay more attention to oxidation and mineralization processes and their effects on the growth of chemolithotrophic and chemoorganotrophic organisms. Also needed is more research into potential groundwater contamination with endotoxins and other biotoxins from land disposal activities. Finally, better indicator systems are sorely needed to take into account properties unique to soil-aquifer ecosystems.

## 2. Microbiology of Surface Water

In Western Europe, agricultural, industrial, and urban expansion have led to a four to five-fold increase in water consumption over the past 100 years. For Denmark, as for many countries, increased demands for potable water have necessitated turning to nontraditional raw water sources. Presently, Denmark derives over 90 percent of its water from groundwater, which accounts for 20 percent of the total groundwater formation and 3 percent of the total precipitation over the country's surface area. However, in order to avoid markedly lowering the water table, Denmark is now attempting to meet demands by exploiting its surface water resources to a greater extent than previously. At the same time, surface water is increasingly being used as a repository for chemical and biological wastes; this trend could put many municipalities, and even nations, on a disaster course if corrective steps are not taken soon.

a. Occurrence of Microorganisms in Surface Water. Bacteria in lakes and streams are either part of the aquatic community or they are of exogenous origin (runoff, waste effluent, animals, or aerosols). Whereas types and numbers

of the indigenous flora are influenced mainly by the availability of nutrients, light, pH, temperature, and dissolved gases, most transient bacteria (e.g., indicators, pathogens, and soil bacteria) live a more or less passive existence in surface water, their survival rates being determined more by negative factors including UV light, predation, microbial antagonisms, and sedimentation [See Section B.3 and E.1]. Therefore, one may expect a rise in the indigenous populations and a reduction in transitory microbes during the summer months. Conversely, winter temperatures tend to prolong survival of indicators and pathogens while curbing activity of the endogenous aquatic community. Heavy winter rains can cause soil runoff in an unprotected watershed and convey nutrients (that stimulate the growth of indigenous flora) and soil bacteria and fungi (that may temporarily mask actual bacterial numbers) to surface waters. However, the effects are generally short-lived.

(i) Chemoorganotrophic Bacteria. Chemoorganotrophic bacteria depend on organic matter for energy as a principal carbon source [See Section A.Intro.]. Aquatic chemoorganotrophs differ from soil chemoorganotrophs in being mostly gram-negative rods. Dominant surface water bacteria belong to the Flavobacterium-Cytophaga, Achromobacter-Acinetobacter-Alcaligenes-Moraxella and Vibrio-Aeromonas groups and to the genus Pseudomonas; and their occurrence in surface waters is related to depth. Together these bacteria can comprise up to 90 percent of colony counts in surface waters (Druce and Thomas, 1970; Yoshimizu, et al., 1976).

Chemoorganotrophs in lakes usually are encountered in numbers of around  $10^2$  to  $10^3$  per ml (at 20°C). In Scotland, three lakes were found to contain respectively  $5.6 \times 10^3$ ,  $3.0 \times 10^4$ , and  $4.1 \times 10^5$  chemoorganotrophs per ml at 20°C incubation. However, colony counts at 20°C can exceed  $10^6$  per ml in highly eutrophic lake water. Even highly oligotrophic lakes (with 1 mg per liter or less organic matter) will have a colony count of around 10 per ml (Godlewska-Lipowa and Jablonska, 1972); and finished drinking water has been shown to contain nutrients sufficient for growth of bacteria when stored in containers at a favorable temperature and in the absence of microbial antagonisms [See Section G.6].

Colony counts on plate count agar at 20°C are often subject to considerable variation depending largely on the organic matter content. The more fastidious of the chemoorganotrophs require a minimum of 10 to 100 mg of organic



matter per liter (Zo Bell, 1943) and the less fastidious will grow in water containing as low as (or lower than) 1 mg of organic matter per l. Benthic chemoorganotrophs, especially those in the upper 10 mm of sediment, occur in much higher numbers and are composed largely of gram-positive bacteria such as Micrococcus, Corynebacterium, Actinomyces, Bacillus, and Clostridium.

Colony counts in streams and rivers vary according to dilution from rainfall and pollution from wastewater. When dilution is low and pollution high, as often occurs with heavy irrigation, bacterial levels will be high and flow rates low. The same holds true for urban communities that remove more water than they replace or that replace it in the form of wastewater. Colony counts at 20°C usually are higher for rivers and streams than for lakes and are higher at 20°C than at 37°C incubation [See Table A.2-1]. Quality criteria for river water are given in Table A.2-2. [See also Sections C.1.a, C.4.h, and D.6].

Certain pathogens and indicator bacteria can grow in the presence of low nutrient concentrations. Both Enterobacter aerogenes and Escherichia coli grew at nutrient levels up to 50 times lower than those required by Streptococcus faecalis as long as conditions were aerobic (Zo Bell, 1943).

(ii) Chemolithotrophic Bacteria. Chemolithotrophic bacteria can grow in aquatic environments of purely inorganic content [See Section A.Intro.]. Soluble salts and carbon dioxide are often present from mineralization and other processes when organic matter has settled in the sediment, depriving chemoorganotrophs of a nutrient source. However, chemolithotrophs can thrive under such relatively clean conditions (Terney, 1973). Table A.2-3 lists some of the important chemolithotrophs, classified on the basis of their growth requirements. Chemolithotrophs are instrumental in the nitrogen and sulfur cycles and can oxidize reduced iron and manganese compounds. Though not responsible for disease, they often are responsible for operational problems at treatment plants and taste, odor, and color problems at the consumer's tap [See Sections F.3.b and G.4].

Nitrification is carried out in the benthos under aerobic conditions, primarily by two chemolithotrophs, Nitrosomonas and Nitrobacter. Denitrification is usually

TABLE A.2-1

## COLONY COUNTS IN FOUR RIVERS OF CZECHOSLOVAKIA

River	Colony Counts (per ml)	
	20°C	37°C
Danube	6,200	1,800
March	7,500	2,800
Vah	2,200	330
Hron	6,100	740

From Daubner, 1972.

TABLE A.2-2

RIVER WATER QUALITY AS DETERMINED BY  
NUMBERS OF CHEMOORGANOTROPHS AT 22°C

Quality of Water	Chemoorganotrophs per ml
Pure river water	< 500
Relatively pure river water	5,000 - 10,000
Moderately polluted river water	25,000 - 50,000
Polluted river water	≤ 100,000
Highly polluted river water	≤ 1,000,000

From Daubier, 1972.

TABLE A.2-3

## CLASSIFICATION OF CHEMOLITHOTROPHIC BACTERIA

Category	Genera and Species
Obligate chemolithotrophs	<u>Nitrosomonas europaea</u> , <u>Thiobacillus thiooxidans</u> , <u>Thiobacillus thioparus</u> , <u>Thiobacillus neopolitanus</u> , <u>Thiobacillus denitrificans</u> , <u>Thiobacillus ferrooxidans</u>
Mixotrophs	<u>Hydrogenomonas</u> , <u>Micrococcus denitrificans</u> , <u>Thiobacillus intermedius</u> , <u>Thiobacillus novellus</u> , <u>Nitrobacter agilis</u>
Heterotrophic chemolithotrophs	<u>Desulfovibrio desulfuricans</u> , <u>Thiobacillus perometabolis</u>

From Rittenberg, 1972.

the result of reductions by chemoorganotrophs such as pseudomonads, although Paracoccus denitrificans (a facultative chemolithotroph), Thiobacillus denitrificans (a strict chemolithotroph), and a few other chemolithotrophs are denitrifiers. Levels of nitrogen and the form in which it enters surface water will influence the numbers of nitrifying bacteria; in turn, relative numbers of nitrifiers and denitrifiers will decide the ultimate form nitrogen is to take: whether ammonia, nitrate, nitrite, or nitrogen gas which escapes to the atmosphere.

Sulfur, upon entering surface waters by way of the atmosphere or through wastewater discharge, sets in motion a number of microbial oxidations and reductions carried out by chemolithotrophic and chemoorganotrophic bacteria. These reactions can lead to the formation of various undesirable sulfurous compounds that not only produce bad tastes and odors, but that also can degrade concrete structures used for water storage and distribution [See Section G.4.b].

There may occur in surface waters both sulfur oxidizing and sulfate reducing chemolithotrophs. Thiobacillus species and Beggiatoa can oxidize sulfides, elemental sulfur, or thiosulfate to acceptable or unacceptable forms. Although all species of Thiobacillus, except T. denitrificans, are obligate aerobes, they inhabit primarily the benthic zone (in numbers as high as or higher than  $10^6$  per g: Fjerdingstad, 1969; Terney, 1973) and can oxidize hydrogen sulfide (which is found only in the oxygen-poor hypolimnion) to sulfuric acid. The presence of hydrogen sulfide may be due to a microbial decomposition of proteins or to the anaerobic reduction of sulfates (or other reducible sulfur compounds) carried out by the gram-negative chemoorganotrophs Desulfovibrio (nonsporeforming) and Desulfotomaculum (sporeforming). Counts of  $10^6$  Desulfovibrio and  $10^5$  Desulfotomaculum per gram have been found in bottom sediments in Denmark (Fjerdingstad, 1969). The thermophile Desulfotomaculum is responsible for hydrogen sulfide odors emanating from hot water tanks where conditions have become anaerobic.

In view of the problems caused worldwide by iron bacteria in surface water, well water, and groundwater supplies, it is surprising that so little is known about actual numbers occurring in raw source waters. Biological oxidation of ferrous compounds to insoluble ferric compounds with consequent encrustations along pipes and in reservoirs and organoleptic changes in finished water, has been reported in Canada, the U.S., the U.K., Scandinavia, Australia,

India, and some African countries (Cullimore and McCann, 1977). In addition, iron oxide or iron hydroxide deposits on bacterial cell surfaces form a protective layer that can hamper the effectiveness of disinfection [See also Sections F.3 and G.3].

The chemolithotroph Thiobacillus ferrooxidans has been found in numbers as high as  $10^6$  per ml in iron-containing waters of Denmark (Fjerdingstad, 1956). Gallionella, Crenothrix, Clonothrix, Toxothrix, and Lieskeela are probably chemolithotrophic and aerobic or microaerophilic; and all have been isolated from surface waters (Cullimore and McCann, 1977). Iron bacteria known to be chemoorganotrophs are Sphaerotilus and Leptothrix, both of which can oxidize ferrous and manganous compounds. They have been isolated from both uncontaminated and contaminated iron-containing waters throughout the world.

Under acidic conditions, only the biological oxidation of iron is significant, whereas at a neutral pH, both biological and chemical iron oxidation can occur. Iron bacteria grow within a temperature range of 5 to 34°C if there is more than 0.2 mg of ferrous ions per liter and if the pH is within a range of 5.4 to 7.2. Some iron bacteria, notably Sphaerotilus, can utilize inorganic compounds for energy and carbon when the required vitamins also are present.

(iii) Phototrophic Bacteria. Photosynthetic organisms, primarily the aquatic bacteria, can inhabit surface waters. Included in this diverse physiological community are genera from the families Rhodospirillaceae (nonsulfur purple and brown bacteria), Chromatiaceae (sulfur purple bacteria), and Chlorobiaceae (green sulfur bacteria). Bacteria from these families oxidize reduced inorganic substances such as molecular hydrogen, hydrogen sulfide, elemental sulfur, or low molecular weight organics. The presence of iron seems important to their metabolism. They require a highly reduced or anaerobic environment in which to carry on anoxygenic photosynthesis (where free oxygen is not a by-product) and therefore occupy a stratum of minimal light penetration near the benthic zone (Buchanan and Gibbons, 1974).

In contrast, the cyanobacteria (or blue-green bacteria, formerly classified as blue-green algae) inhabit the aerobic zone and carry on oxygenic photosynthesis. Unlike the majority of anoxygenic phototrophs, cyanobacteria can fix

atmospheric nitrogen; hence, they can thrive in aquatic environments that lack a combined nitrogen source such as ammonia or nitrate. Their prevalence in oligotrophic, mesotrophic, and especially in phosphate-rich eutrophic bodies of water is attributed to these dual abilities to photosynthesize and to fix nitrogen. It is generally agreed that the growth of cyanobacteria is limited only by the availability of phosphates. Hence, any waters rich in phosphates, such as those receiving phosphate-laden wastewater, tend to accelerate the growth of the organisms.

Massive blooms of species from some genera (e.g., Anabaena, Oscillatoria, Microcystis, Lyngbya, Gleotrichia, Anacystis) have created considerable problems in water treatment facilities by clogging filters and imparting noxious tastes and odors (Benson-Evans and Williams, 1975) [See Section F.3.b]. Some of the cyanobacteria have also been reported to produce toxins that, if ingested, may cause gastrointestinal disturbances (Mackenthun, et al., 1967) [See accompanying section]. Some of the genera mentioned above have been used as indicator organisms for assessing the degree of eutrophication. Great numbers of fish inhabiting shallow waters have perished in winter as a result of frequent severe summer blooms: when the photosynthetic activity of aquatic plants is hindered due to reduced surface aeration and solar insulation (especially in the case of ice cover), dissolved oxygen is depleted as decomposing masses of cyanobacteria settle to the benthic zone.

(iv) Other Microorganisms. Numbers of algae, protozoa, and fungi occurring in a river or lake reflect its nutrient state. Predominant classes of algae occurring in lakes are the Chlorophyceae (green algae) and Bacillariophyceae (diatoms). Up to 100 species of algae have been found in lakes; yet, high diversities and low numbers of algae signify relatively clean conditions whereas low diversities and high numbers signify eutrophic conditions. Algae are photoautotrophs in the light, but can be chemoorganotrophs in the dark. Flagellates of the classes Euglenophyceae and Chrysophyceae are most often implicated as the cause of tastes described as bitter or sweetish and odors described as "fishy", "grassy", "musty", and "earthy" (Palmer, 1962). Freshwater protozoa include genera of the classes Flagellata, Ciliata, and Sarcodina, the latter containing in it the pathogens Acanthamoeba, Entamoeba histolytica, and Naegleria fowleri [See Section B.1.c].

Fungi, including yeasts, are chiefly soil organisms and their mostly accidental presence in water does not appear to affect significantly the quality of drinking water. Yeast cells normally comprise < 1 percent of the microbial flora, but may exceed this level in streams and rivers that receive effluent from certain industries such as breweries or metal works. Yeasts, predominantly Rhodotorula, Candida [See Section C.2.f], Cryptococcus, and Torulopsis were isolated from the St. Lawrence River (Canada) in numbers of from 0 to 9,500 cells per ml (Simard, et al., 1970). Also common to freshwaters are the fungi Trichosporon, Cladosporium, Endomyces, and Deboromyces (Buck, 1975; Daubner, 1972).

b. Lakes and Reservoirs. Lakes and reservoirs (which include any depressions of land created by natural causes, such as glacial and volcanic action, or through human effort, that retain water from rain, rivers, or springs) are the bodies of water most frequently used as sources of drinking water in the U.S. Yet, very little is known about the ecology of microorganisms, and even less about viruses, in such waters.

The waters in lakes and reservoirs, as a group, differ markedly in chemical composition and are frequently classified on the basis of nutrient content or degree of biological productivity. Biological productivity here refers to the amount of organic matter synthesized from inorganic substances through photosynthetic activity; and productivity, as a rule, is a function of the levels of nutrients (e.g., C, N, P, and S) present in the water. Oligotrophic lakes are those lakes relatively low in nutrients or relatively infertile in which nutrient recycling is of the autochthonous (self-nourishing) type. Eutrophic lakes, on the other hand, are productive lakes rich in nutrients of which the major portions are derived from the external environment (allochthonous). Lakes that fall between these two extremes are considered mesotrophic.

Microbial populations within oligotrophic lakes are rich in species diversity but low in numbers; in excessively eutrophic lakes, as a rule, there is less species diversity but a massive increase in the populations of a few species, as in the case of algal blooms. These few typically dominant species (of the genera Anabaena, Microcystis, Lyngbya, and Anacystis) are frequently referred to as index species of eutrophication or pollution.



Some of the major causes of accelerated eutrophication are the discharge of nutrient-rich effluents from sewage plants and septic tanks and of farm runoff. Obvious undesirable consequences of accelerated cultural eutrophication are an increase in turbidity, promotion of a toxic algal bloom [See Section A.2.c], excessive stratification of dissolved oxygen in the summer, or depletion of dissolved oxygen in the winter. Depletion of dissolved oxygen during the winter is attributable to aerobic decomposition of accumulated organic matter (e.g., dead algae and weeds) which removes dissolved oxygen from the water. Consequences of the depletion of oxygen include a drastic alteration in distribution of micro- and macrocommunities within the lake. Anaerobic digestion of sediment organic material by indigenous bottom-dwelling organisms (such as species of Desulfovibrio, Desulfotomaculum, Butyrivibrio, Selenomonas, Clostridium, etc.) generally results in production of reduced inorganic ions (e.g.,  $Fe^{++}$  and  $Mn^{++}$ ) as well as products that impart undesirable tastes and odors.

Most lakes and reservoirs serving as community water sources have characteristic zonation and temperature stratification. Most lakes are rimmed by a relatively shallow littoral zone where nutrient accumulation is highest; further offshore is the limnetic or photic zone where sufficient light is available for photosynthetic activities by primary producers (the phytoplankton), and a profundal zone where photosynthetic activities cease as a result of insufficient light penetration.

The bacteria within the littoral zone are largely representative of soil microflora, but conditions favor the survival of nutritionally nonfastidious gram-negative organisms. Among the notable bacteria frequently encountered here are oxygenic, nitrogen-fixing cyanobacteria (formerly known as blue-green algae); anoxygenic, photosynthetic bacteria (members of Rhodospirillales); chemolithotrophic nitrogen-fixing bacteria (members of Nitrobacteraceae); organotrophic bacteria (such as species of Pseudomonas, Aeromonas, Alcaligenes, and Flavobacterium); gram-positive bacteria (such as species of Bacillus, Micrococcus, Mycobacterium, and Corynebacterium); and various species of Actinomyces. The discharge of sewage effluent may add members of the family Enterobacteriaceae, such as species of Escherichia, Proteus, Enterobacter, Yersinia, and others, some of which may be pathogenic (species of Salmonella, Shigella, Vibrio, etc.).

The viability of pathogens, or of bacteria considered as potential or opportunistic pathogens, is dependent on such factors as available nutrients, temperature, and pH, as well as biotic factors such as predation and antagonism. The grazing of bacteria by protozoa, bacteriovorous bacteria (Bdellovibrio), and bacteriophage in water may destroy millions of bacteria. Further, antibiotic substances produced by some microorganisms may destroy other species. The role of cyanophages, which attack cyanobacteria, remains to be evaluated. In addition, lakes rich in suspended solids may harbor considerable numbers of epiphytes or peritrophic bacteria (such as species of Caulobacter, Hyphomicrobium, Seliberia, Thiodendron, Gallionella, Leptothrix, Crenothrix, and Clonothrix). Some of these have been known to cause considerable problems in the water treatment process, either by fouling sand filters or imparting undesirable tastes and odors.

Lakes that are sufficiently deep generally display temperature stratification during summer. The region of rapid temperature drop with depth is known as the thermocline; water above the thermocline is called epilimnion, and below, the hypolimnion. As a rule, the thermocline layer prevents mixing of epi- and hypolimnion water during summer, but in spring and fall when the temperature of the epilimnion reaches approximately 4°C (the temperature at which water is densest), the cold water begins to sink and causes extensive mixing of both layers of water resulting in complete circulation (holomixis). Lakes which turn twice a year are called dimictic, but there are lakes which fail to turn (amictic), ones which turn once a year (monomictic), or those which turn constantly (polymictic). The last group of lakes are rarely used as source water because they are either under permanent ice cover or are located in colder regions.

As a rule, distribution of micro- and macroflora within the lake ecosystem is neither constant nor necessarily predictable except within wide limits. This is because the conditions of the littoral zone change hourly, from week to week, or season to season, as this region of the lake is subject to the intrusion of sewage effluent, soil runoff, and other external disturbances, such as wind and wave action, utilization of the water by wild animals, and abstraction of water for various human uses.

The total number of microorganisms within the limnetic zone may be a few hundred per milliliter during the quiescent period, but the microbial population immediately after

circulation may reach a few million per milliliter. This change is primarily attributed to disturbance of the bottom sediment and upwelling of nutrients as a result of the circulation. The organic matter stirred up from the benthic zone temporarily furnishes a rich and varied pabulum. Numerous species of aerobic and facultative organisms (Bacillus, Micromonospora, Micropolyspora, Chromobacterium, and Flavobacterium) as well as some strict anaerobes (Bacteroides, Desulfovibrio, Desulfotomaculum, Sporosarcina, Clostridium, Methanobacterium, etc.) previously present in undetectable numbers may multiply enormously, frequently reaching millions per milliliter, and some previously numerous species may be suppressed by newly multiplying antagonistic species. The circulation may be accompanied by increased turbidity and the lakes with an excessively eutrophic condition may actually show an increase in BOD content as well as production of a noticeable hydrogen sulfide odor. Circulation may continue for a few days or weeks, depending on such factors as rate of water temperature change, average depth of the lake, etc.

Microbial communities in lakes and reservoirs are extremely complex and fragile. They are readily altered by internal as well as external influences. External influences not under local control, such as "acid rain", are of considerable concern in the deterioration of water quality especially in those lakes which lack a limestone base. However, cultural eutrophication of a lake is the single most important factor in the deterioration of water quality. Eutrophic lakes tend to promote the bloom of various algae, including toxigenic species; lengthen the viability period or even promote "aftergrowth" of undesirable bacteria; cause increased turbidity; and impart undesirable odors and tastes. The water derived from such lakes requires extensive and costly treatment. Thus, lakes and reservoirs serving as source waters must be protected from external influences that tend to deteriorate water quality.

c. Toxic Cyanobacteria in Raw Water Supplies. There are numerous reports about poisonings of livestock, pets, and wildlife by ingestion of waterblooms of cyanobacteria; and mounting evidence indicates that man may also be affected by toxic cyanobacteria through water supplies (Dillenberg and Dehnel, 1960). Outbreaks of human gastroenteritis which occurred in Charleston, West Virginia, and the area served by the Anacostia Reservoir near Washington, D.C., in the drought years of 1930 and 1931, were attributed to growths of cyanobacteria in the water supplies. The usual bacterial causes

of gastroenteritis could be excluded, but direct toxic effects of the cyanobacteria or associated bacteria were not clearly established.

Recent cases of cyanobacterial toxicity to humans have been reported by Dillenberg and Dehnel (1960) who described cases of human gastroenteritis resulting from the ingestion of heavy blooms of Anabaena, Microcystis, and/or Aphanizomenon from a number of lakes and reservoirs in the province of Saskatchewan, Canada. The most convincing case cited in this review is of a physician who accidentally fell into a lake containing a heavy bloom of cyanobacteria and swallowed an estimated half-pint (250 ml) of water. A few hours later, he suffered stomach pains, nausea, vomiting, painful diarrhea, fever, headache, and pains in limb muscles and joints which lasted for two days. Samples of slimy green stool subjected to laboratory analysis for pathogens (including virus) revealed no Salmonella or Entamoeba, but many cells of Anabaena and Microcystis.

By isolating, growing, and testing (by intraperitoneal or oral administration to laboratory mice) cultures of the most common bloom-forming species (Anabaena flos-aquae [L.] de Breb., Microcystis aeruginosa Kütz. emend Elenkin, and Aphanizomenon flos-aquae [L.] Ralfs.) from a number of different lakes, ponds, and reservoirs, investigators have shown that there are toxic strains of these organisms. They have, in addition, been able to determine fully or partially the chemical structure of at least one toxin from one strain of each of these three species. A number of toxins from newly isolated strains of Anabaena flos-aquae have recently been described (Carmichael and Gorham, 1978), and a toxin from a new strain of Microcystis aeruginosa has recently been found. Slower-acting toxins produced by bacteria associated with these cyanobacteria have also been noted (Gorham, 1965).

Known strains of Anabaena flos-aquae produce four (perhaps six) toxins (Carmichael and Gorham, 1978). The first of these, called anatoxin-a, is an alkaloid with both pre- and post-synaptic neuromuscular blocking activity. Anatoxins-b and d are fast-acting and are suspected of being alkaloids. Anatoxin-c is slower-acting and is suspected of being a peptide.

The effects of a toxin produced by a new strain of Microcystis aeruginosa, called type c, are indistinguishable from those produced by anatoxin-c. Microcystin, the cyclic polypeptide toxin produced by Microcystis aeruginosa NRC-1,

affects the cardiovascular system and produces characteristic lesions of the liver when administered by intraperitoneal injection or by the oral route to mice, guinea pigs, rabbits, chickens, ducks, calves, and a lamb (Konst, et al., 1965). Toxic mixed blooms of Aphanizomenon flos-aquae and Microcystis aeruginosa produced signs that were indistinguishable from microcystin poisoning (Gorham, 1965). Since no cultures were successfully established, it could not be decided whether the toxin came from the Aphanizomenon, the Microcystis, or from both. Blooms of Microcystis toxica Stephens have been reported to produce an alkaloid hepatotoxin of unknown structure.

An atypical strain of Aphanizomenon flos-aquae produces an ichthyotoxin, called aphantoxin, which kills mammals (Gentile and Maloney, 1969). It is a mixture of which one component is, surprisingly, the known alkaloid saxitoxin. Saxitoxin is the paralytic shellfish toxin which affects man and is produced by the marine dinoflagellate Gonyaulax catenella (Schantz, et al., 1975).

The question of whether or not toxins from cyanobacteria, if present in raw water supplies in significant quantities, would survive water purification practices has been considered. Cases in the province of Saskatchewan of poisoning associated with the presence of cyanobacteria led to tests for the occurrence of toxic cyanobacteria in blooms of two impoundments that served as the water supply for three of the province cities. Raw untreated water was either mildly or fatally toxic as determined by intraperitoneal injections into mice (Dillenberg and Dehnell, 1960). These same authors reviewed tests conducted by Wheeler and coworkers in which they found that toxins produced by Microcystis aeruginosa blooms maintained their toxicity after the laboratory equivalent of water purification processes, including alum coagulation, filtration, chlorination, and activated carbon treatment. Massive amounts of activated carbon were needed to render the effluent non-toxic.

Gorham (1962) considered that two of the known cyanobacterial toxins, microcystin and anatoxin-a, would normally be removed or inactivated by the usual water treatment procedures. Moreover, the large doses and high percentage (75 percent or higher) of toxic strain necessary to produce symptoms in animals suggest that the comparatively small amounts of toxins that might remain in a drinking water supply after treatment probably would not be sufficient to cause human poisoning.

One must also consider that strains of different species of cyanobacteria are capable of producing a great variety of toxins, individually and in mixtures. Since some are toxic to man, it could be that others, which may not be eliminated by standard water treatment practices, may also prove toxic. This suggests a need for a comprehensive study of the effects of water treatment practices upon toxins produced by different strains and species of cyanobacteria.

If one could select a set of representative water treatment practices to be evaluated as a model laboratory-scale process, the suggested investigation could proceed in three stages. For each of several known toxic strains of cyanobacteria, one would produce a mass culture and determine the extent of detoxification which resulted from the model process. Then one would concentrate naturally-occurring blooms of cyanobacteria from raw water supplies and measure the amount of detoxification, by the model process, of those blooms which were found to be toxic. Finally, one would grow laboratory cultures from the toxic natural blooms and attempt to confirm the detoxification results more critically.

Such a study would go far towards evaluating the risk to man of consuming treated water produced from sources containing toxic cyanobacterial blooms. It would also help to identify specific treatment practices which are capable of detoxifying such source waters and to suggest possible improvements.

d. Sampling, Transport, and Microbiological Requirements for Raw Surface Water. A council directive submitted to the director of the Commission of the European Communities (Commission of the European Communities, 1975) has proposed that raw surface waters be monitored using microbiological parameters; and a more recent directive (Commission of the European Communities, 1978) has included suggestions for sampling protocol, frequency, and transport, along with ways to ensure analytic reproducibility [See Table A.2-4]. According to this proposal, samples are to be collected from a zone 50 cm below the surface and 50 cm above the bottom; or, if not possible, samples are to be taken at a depth midway between the surface and the bottom. These specifications are meant to ensure that samples will contain bacterial numbers that accurately reflect levels in the water phase and not those in resuspended sediment, from which much higher bacterial counts would be obtained. However, most saprophytic bacteria are concentrated in the few millimeters below the surface.

TABLE A.2-4

PROPOSED WATER QUALITY CRITERIA TO BE USED FOR  
RAW SURFACE WATER SUPPLIES

Category of Raw Surface Water	Samples/Yr, for Population Served		Maximum Concentration Allowed			
	$< 10^5$	$\geq 10^5$	Coliforms/ 100 ml	Thermo-tolerant Coliforms/100 ml	Fecal Streptococci 100 ml	<u>Salmonella</u>
A1 <sup>a</sup>	1	3	50	20	20	0/5 liters
A2 <sup>b</sup>	2	6	5,000	2,000	1,000	0/1 liter
A3 <sup>c</sup>	4	12	50,000	20,000	10,000	

<sup>a</sup>Surface water requiring only simple physical treatment (filtration) and disinfection.

<sup>b</sup>Surface water requiring physical and chemical treatment (coagulation, flocculation, filtration) and disinfection.

<sup>c</sup>Surface water requiring more extensive physical and chemical treatment (coagulation, flocculation, filtration, along with supplementary treatment such as active carbon) and disinfection with chlorine and possibly ozone.

(COMMISSION OF THE EUROPEAN COMMUNITIES, 1975 AND 1978)

On the other hand, strong correlations were found between presumptive total coliform MPN's in sediments and virus numbers in recreational coastal waters (Goyal, et al., 1978). Moreover, sediments can serve as a reservoir for enteroviruses which may become resuspended in the water phase during heavy rains (la Belle and Gerba, 1979). The microbiological quality of sediments also needs periodic evaluation, possibly by surveying sediment samples for coliforms and thermo-tolerant coliforms as well as fecal streptococci or Clostridium perfringens [See Section C.1].

As wastewater treatment practices become more complex, there is a greater possibility of reducing indicators without necessarily producing concomitant reductions in some of the more resistant organisms such as viruses and protozoa. Both viruses and parasites may persist for extended periods in water and are fairly resistant (especially parasites) to chlorine [See Section B.3, E.1, and E.5.a]. By not including tests for viruses, and perhaps certain parasites, the Commission of the European Communities proposal does not take into account consequences from contamination of surface water with treated wastewater.

Another pollution parameter not dealt with in the Commission's proposal is that of colony counts at 20 to 22°C, which would enable detection of psychrophilic organisms. Tests for these organisms could serve to indicate any heavy influx of organic and inorganic pollutants into surface waters [See Sections C.1.a and D.6]. Such an occurrence could give rise to algal and cyanobacterial blooms and could increase opportunities for biotoxin production. In addition, the presence of several potentially pathogenic bacteria, and others of special concern to the food industries, has been associated with these blooms (potentially pathogenic species of Aeromonas have been observed in large masses of dying algae: Simudi, et al., 1971). Species of Klebsiella, an opportunistic pathogen, are known to propagate in water containing wastes from textile, lumber, and sugar industries. Strains of these bacteria frequently are adapted to colder environments and are able to grow at temperatures ranging between 0 and 15°C [See Section C.2.d].

e. Protection of Surface Water. It is important to recognize the connection between surface water contamination problems and waste disposal problems. One will not be solved without the other, for even adequately treated surface waters have caused disease when recontamination occurred



during distribution. Out of 54,935 cases in the U.S. (1946 to 1970) attributed to surface water contamination, 8,992 of these were associated with "treated" surface water (Craun and McCabe, 1973).

Surface water, usually to a far greater extent than groundwater, is exposed to various kinds of contamination. In countries where the drinking water supply is derived from surface waters, measures to protect against chemical, physical, and biological deterioration need upgrading. Laws to protect surface water should be more restrictive and more specific; and they must be backed up with adequate provision for enforcement. The discharge (including sub-surface seepage) of raw or inadequately treated waste into raw source waters should be prohibited; and minimum distances from freshwater sources for disposal of wastes need precise delineation. Dogs and motor boats should not be allowed, nor is swimming acceptable in waters designated for potable use. Tight restrictions should be placed on camping, sailing, and other recreational activities in or around surface water sources [See also Section E.1].

However, no amount of regulation will eliminate all microbiological or chemical problems because surface waters will always be in unavoidable contact with wild animals, especially migratory birds, and because some organisms (e.g., cyanobacteria, Pseudomonas, Alcaligenes, Chromobacter, Acinetobacter, Vibrio, Aeromonas, Yersinia, and Bacillus) may continue to grow (albeit in lower numbers) after all waste discharge has ceased. The most difficult, yet the most critical, issue to deal with is that of initiating steps to curb entry of pollutants into surface waters. Beyond this, authorities can only ensure hygienic safety by conducting routine and appropriate analyses of raw source waters and by making sure that all surface waters used for drinking purposes receive complete and continuous treatment before distribution.

Programs for routine analysis should be selected on the basis of knowledge about: (1) what conditions favor propagation of pathogens, potential pathogens, and cyanobacteria; (2) what conditions favor production of undesirable compounds by chemolithotrophs (notably iron bacteria) and chemoorganotrophs; (3) types of information that can be obtained from microbiological examination of sediments; and (4) what hazards are associated with the presence of viruses, protozoan cysts, metazoan eggs, and endotoxins and other biotoxins in surface water. Mapping of waterborne disease

outbreaks [See Section B.5] should be carried out in conjunction with microbiological monitoring, with special attention paid to possibilities for growth of hitherto unrecognized pathogens such as Yersinia enterocolitica [See Section B.1.a(iii)], Campylobacter fetus [See Section B.1.a(viii)], and Legionella pneumophila (Center for Disease Control, 1978e). As different pathogens exhibit different virulence in the host and different stabilities in the aquatic environment [See Sections B.3 and B.4], the kinds as well as numbers of pathogens in a given source water should be determined prior to decisions about type and rigor of drinking water treatment [See Section E].

All of these issues are part of one overriding concern: that of finding ways, some of which have been discussed in this report, to ensure that surface water used for drinking purposes shall be protected, to the utmost extent possible, from the discharge, runoff, or seepage of wastes.

### 3. Survey of the Bacteriological Quality of Raw Water Supplies from Nine Countries

An important consideration to be dealt with in Topic Area A, and one which impinges on every other section of Project Area III, concerns the differences from one waterworks to the next and from one country to the next, in bacteriological quality of the raw water supply. The tables and text that follow are the result of surveys taken of waterworks facilities from nine developed countries (Norwegian Institute of Water Research, 1980). In order to draw a basis for comparison, the parameters chosen were total and thermo-tolerant coliforms, the widely used and accepted indicators of water quality.

One problem encountered was the variation among countries in methods for sampling and analysis [See Section D.1 to 5]. Another weakness of the study is that, except for the Netherlands, Norway, and Sweden, information from waterworks in the various countries surveyed represents only a small part of the total raw water supply and population served. On the other hand, each country's national contact for the drinking water microbiology project, who was responsible for collecting data, was instructed to choose representative raw water supplies wherever feasible. Though the flaws in this study cannot be ignored, neither must the reader discount the knowledge to be gained from this type of study (one that no international organization has as yet undertaken). It is hoped that documentation and comparisons

of raw water quality in the various countries participating in this survey will lead to improvements where warranted. Data were gathered principally from sampling and analyses of raw water during the year 1977, except in cases where no samples had been taken that year. Results were then requested for the previous or the following year.

a. Size of Waterworks, Source of Raw Water, and Sampling Frequencies. The number of people served by a waterworks will be reflected in the size of that facility [See Table A.3-1]. Thus, small waterworks predominate in Norway, most facilities in Sweden serve a medium-sized population, and the other countries surveyed (except France) presented data from waterworks, most of which serve > 20,000 people. Apparently all but one waterworks (UK) in this study serve > 1,000 people. Data from Norway and Sweden are the most complete, representing the majority of waterworks in these countries serving > 1,000 people.

Norway derives most of its drinking water from surface water sources. Although there are more suppliers of ground-water than of surface water in Sweden, a larger proportion of the population receives water from surface sources; likewise, in the Netherlands, 50 percent or more of the population uses surface-derived water [See Table A.3-2].

Whereas most waterworks in Sweden sample one to six times per year, the sampling frequency in Norway falls more evenly into all the categories listed in Table A.3-3. A large number of suppliers take no samples, but there also is a sizeable group of them that sample > 26 times per year. In Sweden, only groundwater may bypass routine monitoring and treatment, but this also can be true of some surface water supplies in Norway. Although epidemiological and environmental conditions in Norway appear stable, Norwegian regulations specify that treatment and routine bacteriological monitoring of all surface water supplies are required. One explanation for the apparent discrepancy is that many Norwegian waterworks have not yet received governmental licensing. The other countries (except France) reported high sampling frequencies, which probably is due either to the size of the waterworks or the level of pollution.

TABLE A.3-1

## RECORDED WATERWORKS BY POPULATION SERVED

Country	< 5,000	≥ 5,000 to < 20,000	≥ 20,000	Total Number of Waterworks
Canada	5	8	14	27
Denmark	-	-	-	13
UK	1	5	17	23
France	4	-	2	6
FRG	-	-	9	9
Netherlands	-	-	3	3
Norway	222	91	31	344
Sweden	24	126	60	216
US	2	1	7	10

TABLE A.3-2

## RECORDED WATERWORKS SERVING MORE THAN 1,000 PEOPLE

Country	Groundwater		Surface Water		Total		Total National Populations	% of Population Served
	People Served	Number Water-works	People Served	Number Water-works	People Served	Number Water-works		
Canada	168,000	11	3,204,000	16	3,372,000	27	23 x 10 <sup>6</sup>	14.7
Denmark	-	11	-	2	860,000	13	5 x 10 <sup>6</sup>	17.2
UK	357,000	12	7,528,000	11	7,885,000	23	46 x 10 <sup>6</sup>	17.1
France	30,000	5	240,000	1	270,000	6	53 x 10 <sup>6</sup>	0.5
FRG	3,000,000	2	5,600,000	7	8,600,000	9	61 x 10 <sup>6</sup>	14.1
Netherlands	0	0	7,000,000	3	7,000,000	3	14 x 10 <sup>6</sup>	50.0
Norway	61,000	19	2,750,000	325	2,811,000	344	4 x 10 <sup>6</sup>	70.3
Sweden	1,967,000	118	2,977,000	98	4,944,000	216	8 x 10 <sup>6</sup>	61.8
US	236,000	5	360,000	5	596,000	10	217 x 10 <sup>6</sup>	0.3

TABLE A.3-3

FREQUENCY OF BACTERIOLOGICAL ANALYSES OF RAW WATER  
AT THE RECORDED WATERWORKS

Country	Number of Analyses per Year					Total
	0	1-6	7-12	13-26	> 26	
Canada	0	2	1	11	13	27
Denmark	-	-	-	2	-	13
UK	0	0	3	0	20	23
France	0	4	1	0	1	6
FRG	0	0	0	0	9	9
Netherlands	0	0	0	0	3	3
Norway	107	82	51	28	76	344
Sweden	37	120	40	5	14	216
US	0	0	0	2	8	10

b. Bacteriological Quality of Raw Water Supplies.

Many surface water sources in Norway, and some in Sweden, show high standards of bacteriological quality (Sweden tests for total, but not for thermo-tolerant, coliforms). Except for Canada, which reported relatively low coliform levels at some waterworks, raw surface water in the other countries surveyed appears to be of low bacteriological quality [See Tables A.3-4 and A.3-5]. In contrast, but to be expected, groundwater sources in most countries were of high bacteriological quality (results from the FRG are based only on tests for thermo-tolerant coliforms in groundwater) [See Tables A.3-6 and A.3-7].

Most of the waterworks surveyed, in most of the countries, reported extensive treatment of water prior to distribution to the consumer. In cases where the raw water received only minimal (aeration or microstraining whereby water is filtered through finely woven fabrics of stainless steel to remove suspended solids) or no treatment, the bacteriological standards usually indicated water of potable quality [See Table A.3-8]. Exceptions were noted for France, Norway, and Sweden. All minimally treated or untreated source waters reported for Canada, France, and the U.S., and most in Sweden are derived from aquifers; in Norway, however, they are derived largely from surface water sources.

c. Conclusion. This tabulation serves to point up the large variation in raw water quality in the different countries surveyed. Where the raw water quality is good, sampling frequencies often tend to be low and the water receives little or no treatment. However, infrequent sampling and testing cannot be expected to alert a supplier quickly to changes in conditions in the community or to a sudden influx of contaminants into the water supply.

Countries such as Norway and Sweden, where waterworks are numerous and predominantly of small or medium size, have greater flexibility in finding means to supply safe, potable water. At the same time, however, there is less centralized control and uniformity of policy for managing and treating raw water supplies.

Those countries fortunate enough to possess water of high bacteriological quality are encouraged to enact policy that will assure its continued excellence.

TABLE A.3-4

## BACTERIOLOGICAL QUALITY OF SURFACE WATER: TOTAL COLIFORMS

Country	Number of Total Coliforms per 100 ml									
	< 2		≥ 2 to < 30		≥ 30		No Data Submitted		Total	
	People Served	Number Water-works	People Served	Number Water-works	People Served	Number Water-works	People Served	Number Water-works	People Served	Number Water-works
Canada	20,000	1	128,000	4	3,056,000	11	-	-	3,204,000	16
Denmark	0	0	-	1	-	1	-	-	-	2
UK	0	0	41,000	1	7,487,000	10	-	-	7,528,000	11
France	0	0	0	0	240,000	1	-	-	240,000	1
FRG	-	-	-	-	5,600,000	7	-	-	5,600,000	7
Netherlands	0	0	0	0	7,000,000	3	-	-	7,000,000	3
Norway	257,000	113	938,000	106	249,000	32	306,000	74	2,750,000	325
Sweden	224,000	16	970,000	40	1,389,000	32	394,000	10	2,977,000	98
US	170,000	1	44,000	1	146,000	3	-	-	360,000	5



TABLE A.3-5

## BACTERIOLOGICAL QUALITY OF SURFACE WATER: THERMO-TOLERANT COLIFORMS

Country	Number of Thermo-Tolerant Coliforms per 100 ml									
	< 2		≥ 2 to < 30		≥ 30		No Data Submitted		Total	
	People Served	Number Water-works	People Served	Number Water-works	People Served	Number Water-works	People Served	Number Water-works	People Served	Number Water-works
Canada	22,000	2	2,747,000	9	422,000	4	13,000	1	3,204,000	16
Denmark	0	0	-	2	0	0	-	-	-	2
UK	0	0	41,000	1	7,487,000	10	-	-	7,528,000	11
France	0	0	0	0	240,000	1	-	-	240,000	1
FRG	0	0	0	0	5,600,000	7	-	-	5,600,000	7
Netherlands	0	0	0	0	7,000,000	3	-	-	7,000,000	3
Norway	1,365,000	150	404,000	50	59,000	7	923,000	118	2,750,000	325
Sweden	-	-	-	-	-	-	2,977,000	98	2,977,000	98
US	-	-	-	-	-	-	360,000	5	360,000	5

TABLE A.3-6

## BACTERIOLOGICAL QUALITY OF GROUNDWATER: TOTAL COLIFORMS

Country	Number of Total Coliforms per 100 ml									
	< 1		≥ 1 to < 2		≥ 2		No Data Submitted		Total	
	People Served	Number Water-works	People Served	Number Water-works	People Served	Number Water-works	People Served	Number Water-works	People Served	Number Water-works
Canada	151,000	9	16,000	2	0	0	-	-	167,000	11
Denmark	-	11	0	0	0	0	-	-	-	11
UK	337,000	11	0	0	20,000	1	-	-	357,000	12
France	2,000	2	0	0	28,000	3	-	-	30,000	5
FRG	-	-	-	-	-	-	3,000,000	2	3,000,000	2
Netherlands	0	0	0	0	0	0	0	-	0	0
Norway	50,000	15	6,000	1	0	0	5,000	3	61,000	19
Sweden	731,000	32	511,000	43	304,000	12	421,000	31	1,967,000	118
US	223,000	2	13,000	3	0	0	-	-	236,000	5

TABLE A.3-7

## BACTERIOLOGICAL QUALITY OF GROUNDWATER: THERMO-TOLERANT COLIFORMS

Country	Number of Thermo-Tolerant Coliforms per 100 ml									
	< 1		≥ 1 to < 2		≥ 2		No Data Submitted		Total	
	People Served	Number Water-works	People Served	Number Water-works	People Served	Number Water-works	People Served	Number Water-works	People Served	Number Water-works
Canada	142,000	9	0	0	0	0	25,900	2	168,000	11
Denmark	-	11	0	0	0	0	-	-	-	11
UK	337,000	11	0	0	20,000	1	-	-	357,000	12
France	29,000	4	0	0	1,000	1	-	-	30,000	5
FRG	3,000,000	2	0	0	0	0	-	-	3,000,000	2
Netherlands	0	0	0	0	0	0	-	-	0	0
Norway	54,000	14	0	0	0	0	-	-	61,000	19
Sweden	-	-	7000	5	-	-	1,967,000	118	1,967,000	118
US	-	-	-	-	-	-	236,000	5	236,000	5

TABLE A.3-8

BACTERIOLOGICAL QUALITY OF RAW WATER  
RECEIVING MINIMUM<sup>a</sup> OR NO TREATMENT

Country	Number of Total Coliforms per 100 ml				Total
	< 2	≥ 2 to < 30	≥ 30	No Value	
Canada	5	0	0	0	5
Denmark	-	-	-	-	-
UK	0	0	0	0	0
France	2	2	1	0	5
FRG	0	0	0	0	0
Netherlands	0	0	0	0	0
Norway	72	25	9	34	140
Sweden	35	3	2	18	58
US	3	0	0	0	3

<sup>a</sup>Minimum treatment -- microstraining or aeration.

#### 4. Summary

As the use of water and the disposal of wastes become more diversified and intensive, those in positions of authority will be required to effect needed changes in resource management policy. In order to make correct decisions, a water supplier will have greater need of information about the impact of water from aspects of human activity, from the siting of waste discharges, meat processing plants, and stockyards, to the local incidence of disease.

Currently most drinking water is derived from surface water sources; but in many cases, deteriorating quality has led to the search for water, such as ground water, that is better protected from human activities. At the same time, the increasing use of soil in treatment and disposal of wastewater raises safety questions in that the dynamics of microorganisms in soil and groundwater are, as yet, imperfectly understood and are inadequately controlled by bacteriological monitoring of aquifers.

Each of these entities, surface water and groundwater, brings with it a distinctive ecological system that responds differently to inputs of waste at different seasons; hence, byproducts of microbial interactions with organic and inorganic matter can be vastly dissimilar, as can conditions for survival and propagation of indicators and pathogens. Surface water, although more vulnerable and more enriched with nutrients and aquatic flora, is essentially a hostile environment to human intestinal microorganisms. Groundwater, which usually occurs as a result of some form of soil filtration, is relatively free of microorganisms. However, once pollution of the aquifer has taken place, conditions favor the persistence of whatever organism initially gained entry. It is important, therefore, that water authorities regularly monitor groundwater, as is generally recommended for surface water, and that they be vested with some legal recourse to impose sanctions in the event of any infringement of regulations.

Where large populations receive their water from one central supplier there is an inherent susceptibility to total disruption of the water supply as a result of a war or natural disaster, especially if alternative raw water sources are limited. On the other hand, if circumstances such as war necessitated that many people gather where normally only a few people lived, it would be incumbent on the responsible agency to have on hand sufficient volumes of potable water.

A comparable problem, in terms of availability of potable water, arises whenever large numbers of people are assembled together at resort areas during holidays.

Protection of our source waters will require more than just good intentions if future generations are to receive from their governments a sufficient quantity of safe and palatable drinking water. Careful and appropriate microbiologic monitoring along with prompt correction of problems are essential.

## B. MICROBIAL PATHOGENS TRANSMISSIBLE BY WATER

Drinking water is a potential vehicle for pathogenic organisms if it becomes contaminated with human or animal feces. Fecal contamination can occur at the raw water source or anywhere along a distribution system. The presence of fecal contaminants in finished water can also result from accidental or routine inefficiency during the treatment and disinfection of a raw water. A result of such fecal contamination may be that the consumer will ingest some quantity of bacterial, viral, or parasitic organisms. The effects of these will depend both on the demographic and epidemiologic conditions, and on the overall numbers and virulence of the organism ingested.

The problem of transmission of microbial pathogens through drinking water has changed with time; our perception of the problem has also been changed by the development of new research results. Certain bacteria of fecal origin (e.g., Salmonella, Shigella, and Vibrio cholerae) are less prevalent than they once were, but are now more likely to have acquired some resistance to antibiotics. Other microorganisms, such as several of the enteric viruses, have been held in check over the last 25 years. However, there are those (such as the hepatitis A virus) which still pose problems that are far from being solved. Likewise, there appear to be more frequent occurrences of gastroenteritis in which the causative agent is undetermined but strongly suspected of being a virus. Parasitic protozoa, such as Giardia lamblia, also seem to be an occasional cause of waterborne gastroenteritis.

The most important epidemiologic issue to be addressed by the developed countries is the extent to which various microorganisms can cause sporadic cases or inapparent infections in the consuming population via the water supply route. To be able to predict accurately, one must not only understand epidemiologic facts, but must also take into account conditions under which pathogens survive in water

and retain their capacity to infect. There are deficiencies in present information gathering systems and in methods for identifying the responsible waterborne agent. Therefore, if decisions are to be made on the basis of current epidemiological data, the limitations to this approach must be recognized.

Research on and detection of pathogenic microorganisms in polluted drinking water is hampered by various factors associated with waterborne spread of disease:

1. A mass infection leading to epidemic manifestations in the consumers is generally sporadic and isolated rather than regular and repetitive.
2. Several days or even weeks can intervene between contamination of the drinking water and appearance of the first symptoms of illness. By the time water is suspected of being the vehicle of transmission the pathogenic agents most often will have disappeared from the contaminated water.
3. Even when the causative agent remains present in the water, its numbers are usually quite low compared to total bacterial densities in the water.
4. It is often necessary to eliminate other interfering organisms present in the sample which could otherwise mask the presence of pathogens.
5. Finally, the choice of recovery methods must take into account probable stressed states of pathogens derived from a more or less hostile aqueous environment.

For all of these reasons, the following protocol is especially important when culturing for microorganisms in water:

1. Concentration of an appropriate volume of water sample.
2. Enrichment (in certain cases pre-enrichment) in specific liquid media and transfer to solid selective media.
3. Use of an optimal incubation temperature, chosen on the basis of the suspected causal agent.



The incidence of pathogenic organisms in drinking water, and the means by which information about them can be obtained, are the concerns of this section. Most papers in the first part, dealing with individual pathogens, are organized according to the format: (1) characterization and pathogenesis, (2) stability and sources, (3) epidemiology, and (4) detection methods.

## 1. Categories and Properties of Waterborne Microbial Pathogens of Humans

### a. Bacteria

(i) Salmonella. The genus Salmonella is made up of gram-negative, nonsporeforming, generally motile bacilli having many biochemical reactions in common with other members of the family Enterobacteriaceae (Buchanan and Gibbons, 1974). It is a very large group consisting of 1,200 known serotypes, classified according to possession of O and H antigens. Biotypes, determined by different sugar fermentation patterns, or serotypes demonstrated to be resistant to antibiotics can serve as markers in epidemiological investigations. Plasmid transfers with various strains of Enterobacteriaceae over the last several years have conferred antibiotic resistance to certain of the Salmonella serotypes.

All serotypes of Salmonella are pathogenic to humans, causing mild to acute gastroenteritis and very occasionally death. Typhoid fever, caused by S. typhi and paratyphoid fever, caused by S. paratyphi A or B are both enteric fevers that occur only in humans. The other Salmonella serotypes are responsible for foodborne intoxication accompanied by mild to acute gastroenteritis, but rarely death. Referred to as salmonellosis, these milder forms occur frequently in humans and wild or domestic animals.

The organism grows either continuously or intermittently in the intestines of sick individuals or clinically healthy carriers and is excreted through the feces. Salmonella is excreted by infected individuals in the human population (exclusively so for S. typhi), by infected farm animals, by domestic pets, and by other warm-blooded animals in the wildlife population. The average number of individual humans excreting Salmonella at any given time will vary, from < 1 percent to 3.9 percent based on information from studies in several countries throughout the world [See Section B.2]. As a result, a large constant reservoir of

Salmonella exists in the environment, although accurate carrier rates are difficult to obtain since infected yet asymptomatic animals can be included among the healthy carrier population.

Salmonella densities, as well as the number of Salmonella serotypes present in sewage discharging to receiving waters, vary with the number of people served and the extent of community infection. Salmonella strains were regularly found in the sewage system of a residential area of 4,000 persons (Harvey, et al., 1969). A sewage collection network of 50 to 100 homes is considered by Callaghan and Brodie (1968) to be a minimal size for detecting salmonellae.

Streams, lakes, and rivers receiving discharges of meat processing wastes or effluents of untreated or ineffectively treated community sewage may contain substantial numbers of salmonellae (Geldreich, 1972). Researchers recently recovered 32 serotypes both from sewage effluent and from downstream sections on the Oker River, Germany (Popp, 1974). Kampelmacher and Jansen (1973) calculated that the Rhine and Meuse Rivers carried approximately 50 and seven million salmonellae per second, respectively [For persistence of Salmonella in water, See Section B.3].

Fish living in polluted water may ingest Salmonella and become vectors of pathogen transport. Salmonella presence in animal feed, notably fishmeal, is a case in point. Experiments with carp suggest that S. typhi survived for five to six days in the intestinal tract when the water temperature was 24 to 27°C, and for six to seven days at water temperatures of 1 to 5°C (Lee, 1972). When researchers sought evidence for possible Salmonella multiplication within the fish gut, they instead discovered a progressive die-off of S. typhi in intestinal material from carp and bluegill at water temperatures of both 10 and 20°C. However, substantial multiplication of S. typhimurium occurred in 72 h at 20°C in fecal material from both fish species (Geldreich and Clarke, 1966).

Drinking untreated, unprotected surface water presents the greatest risk to the consumer. S. typhi or S. paratyphi are the agents responsible for most waterborne outbreaks due to Salmonella contamination of water supplies; other salmonellae produce illness only after growth in food at ambient temperatures. Water supplies implicated in Salmonella outbreaks have included individual water systems, semi-public water systems, systems on passenger cruise liners, and small community municipal supplies. While large

municipal water supplies are not a common source of Salmonella outbreaks, the number of cases involved is often large and represents a major epidemic in the community.

The 1965 salmonellosis outbreak, traced to an unchlorinated water supply in Riverside, California, is to date the largest epidemic in modern times to be caused by salmonella contamination of a municipal water system. More than 16,000 people became ill, and three of them died (Boring III, et al., 1971). Negative coliform readings, reported prior to the outbreak may have been the result of suppression by high densities of non-coliform bacteria (Geldreich, et al., 1972). Muller (1964) found Salmonella in chlorinated drinking water that showed an absence of coliforms, yet had been contaminated with 100,000 l of floodwaters during distribution.

Properly constructed wells, located in high quality aquifers protected from surface contamination, generally afford a good untreated potable water supply free of microbial pollution. Unfortunately, not all wells meet such standards. Five cases of typhoid fever occurred in an area served by individual shallow wells drilled into a layer of river bed gravel. Septic tanks or cesspools were located nearby. In one instance, only 60 meters separated a well site from the home sewage disposal system of a known S. typhi carrier (Center for Disease Control, 1972).

If groundwater is subject to surface contamination, continuous disinfection of water abstracted for potable use is essential. Neglect of this critical requirement led to the largest reported outbreak of typhoid fever (210 cases) to occur in the U.S. since 1939. This outbreak occurred at a farm labor camp in Dade County, Florida (Pfeiffer, 1973). Engineering evaluations revealed that chlorination of the wells (known to have had a history of intermittent contamination) was interrupted and consequently the water supply became a vehicle of infection.

Distribution pipe slimes, rich in iron, manganese and organic materials, support the growth of Salmonella and E. coli (Woratz and Bosse, 1968). Researchers, investigating an outbreak of S. bareilly in a maternity hospital, isolated the organism from one-third of the water taps examined; and from all of the water storage tanks (Mendis, et al., 1976). Upon further examination, S. bareilly was found growing on the interior surfaces of water taps and on the walls of the water storage tanks. After the tanks and lines were cleaned and disinfected, no further evidence of Salmonella was found in the water system.

Salmonella occurs and can be anticipated in polluted water, but other organisms present during sampling can interfere with Salmonella detection. There is no single method that will ensure recovery of all Salmonella serotypes present in a given sample, so a combination of methods is necessary. Negative results by any method chosen do not necessarily imply the absence of all salmonellae nor the absence of other pathogens. There are presently no standardized methods for isolating Salmonella from water, although the Committee of the European Economic Community, the World Health Organization, and the International Standards Organization are working to establish standardized procedures. The following, therefore, presents summaries of procedures that may need modification to fit a particular set of circumstances.

Since Salmonella ordinarily occur in lower numbers than expected for sanitary indicator bacteria, it must initially be concentrated from large volumes of water samples. A qualitative analysis may be performed by submerging gauze swabs in flowing water, thus exposing the swabs to a large volume of water (American Public Health Assoc., 1976). After three to five days of submergence at the sampling site, the swab is retrieved, placed in a sterile plastic bag inside a container with ice, and sent to the laboratory for processing within 6 h after sample collection. The swab is not a perfect entrapment device since some salmonellae may pass through, others may desorb from the swab during exposure period, and the volume of water in contact with the swab is unknown. Furthermore, since the swab is submerged for several days, what results is a composite which does not reflect changes in or cycling of Salmonella densities at the sampling site.

The diatomaceous earth procedure often produces better results than the swab method when floating solids are present, such as in sugar beet effluents, paper mill wastes, and waters containing massive algal (and cyanobacterial) blooms. In this procedure, the water sample is filtered through a plug of diatomaceous earth to concentrate the organisms (Brezenski and Russomanno, 1969). Since known volumes of water or wastewater are filtered through the diatomaceous earth, the procedure provides a quantitative approach to salmonellae detection.

A membrane filter may be used to concentrate organisms, including salmonellae, from a water sample provided sample turbidity does not clog membrane pores and prevent filtration. Samples taken from suspect potable water supplies (including wells) can be anywhere from 100 ml to several

liters, depending on the concentration and characteristics of the suspended solids.

Using a cartridge filter permits 20 l or more of sample to be filtered and is particularly applicable to waters that have low concentrations of organisms (Levin, *et al.*, 1974). Water is drawn (under negative pressure) through a filter of borosilicate glass microfibers bonded with epoxy resin. After filtration, the filter cartridge is separated aseptically from the holder and placed in the enrichment broth. If high numbers of background organisms are present, this technique will not easily recover Salmonella. As with other filtration procedures, sample turbidity will slow the filtration rate. Pre-enrichment for Salmonella can be accomplished with buffered peptone water. Selective enrichment for Salmonella after concentration requires selenite, Rappaport, or tetrathionate broth. Selenite enrichment broth may be combined with dulcitol to improve selectivity for salmonellae. However, dulcitol selenite may retard the recovery of S. typhi, S. cholerae-suis, S. enteritidis biotype paratyphi A, and S. pullorum because these species ferment dulcitol slowly (Raj, 1966). Mannitol selenite broth has been recommended for isolation of S. typhi.

Tetrathionate and selenite broths may be modified by the addition of brilliant green dye to enhance selectivity for salmonellae other than S. typhi. However, tetrathionate broth is reportedly toxic to salmonellae at a temperature of 43°C (McCoy, 1962).

Salmonella strains have been further selected and separated from other bacteria in polluted water samples with a variety of enrichment media at various incubation temperatures. Because other bacteria in the sample may interfere with Salmonella detection, temperatures above 37°C have been used to inhibit the growth of background microorganisms. In general, most researchers agree that 41 to 42°C (preferably 41.5°C) is an optimum incubation temperature for recovery of the largest number of Salmonella in the enrichment procedure. However, since some salmonellae grow more vigorously at 35 to 37°C, parallel enrichment cultures at these temperatures may be performed when feasible; also, when isolating, purifying, or cultivating salmonellae for biochemical testing, a 35 to 37°C incubation temperature is recommended (American Public Health Assoc., 1976).

The fluorescent antibody (FA) technique can be used to screen rapidly for cultures taken directly from prior enrichment (American Public Health Assoc., 1976). This technique

requires careful interpretation of fluorescence; any positive FA results must be confirmed by the conventional biochemical and serotyping techniques.

Pure cultures of Salmonella may be isolated from the enrichment broths by streaking every 24 h for three days onto the surface of selected differential plating media. These media are: xylose lysine desoxycholate (XLD) agar, brilliant green (BG) agar, xylose lysine brilliant green (XLBG) agar, and bismuth sulfite medium. Because bacteria other than salmonellae may grow and possibly interfere with isolation and differentiation of suspect Salmonella strains, using brilliant green agar at an elevated temperature of 41.5°C will reduce the number of these interfering organisms. However, the elevated temperature and this medium may inhibit development of some Salmonella serotypes. After incubation, the cultures are examined for typical colonies of salmonellae which are then characterized biochemically and serologically.

Biochemical reactions are used to characterize the suspect Salmonella isolates recovered and permit a separation from closely related bacteria. Four major Salmonella sub-genera can be differentiated by selecting tests to obtain reactions for dulcitol, lactose,  $\beta$ -galactosidase, d-tartrate, mucate, malonate, gelatin, and KCN. Ordinarily, salmonellae do not ferment lactose, sucrose, malonate, and salicin, but do ferment glucose, inositol, and dulcitol.

These tests, using pure culture isolates, can be made in single tube media, or in commercial multitest systems. The multitest systems permit the examination of large numbers of isolates in a relatively short time. All tentatively identified Salmonella isolates are then submitted to serological confirmation.

To prepare for serological verification of Salmonella strains, the pure culture isolate is transferred to a brain heart infusion agar slant and incubated for 18 to 24 h to insure maximum strain vigor. A range of polyvalent and individual somatic or flagellar antisera should be used in agglutination tests for determining Salmonella serotypes.

Especially when testing for Salmonella, the dedication and skill with which the microbiologist conducts his examinations, and his critical review of culture reactions are what determine the validity of the results.

(ii) Shigella. This genus is composed of a group of closely related gram-negative bacteria that cause mild to acute bacillary dysentery in man. These bacteria have many biochemical reactions in common with other members of the family Enterobacteriaceae to which they belong. In addition, they are non-motile, do not normally ferment lactose, yield positive methyl-red and negative Voges-Proskauer reactions, and do not grow on citrate medium (Wilson and Miles, 1975).

The Shigella genus is divided into four main subgroups based on a combination of biochemical and serological characteristics: Subgroup A (Shigella dysenteriae -- several serotypes), Subgroup B (S. flexneri -- several serotypes), Subgroup C (S. boydi -- several serotypes), and Subgroup D (S. sonnei -- one species or serotype). The shigellae are not particularly heat resistant and are killed by temperatures of 55°C in one hour. They are even more sensitive to higher temperatures and they will die within several hours when in moist stool specimens that have become acidic from bacterial growth. However, Shigella can survive for many days in clean, cool water.

All Shigella species cause bacillary dysentery (also called shigellosis) exclusively in humans and some primates. Infection normally is restricted to the intestinal tract and the incubation period is only 48 h. The organism enters the small bowel, multiplies, then proceeds to the terminal ileum and colon where it penetrates the epithelial cells and multiplies again. The result is inflammation, sloughing of cells, and ulceration. Dysentery is a disease of the large bowel and the mesenteric lymph nodes. Symptoms include fever and diarrhea characterized by watery feces tinged with blood, mucus, and groups of polymorphonuclear leukocytes. The case-fatality rate varies widely according to the age and general health of infected individuals and also the Shigella species involved. S. dysenteriae is the most dangerous, possibly because it produces a particularly cytotoxic exoenterotoxin not known to be produced by any of the other species (Hollister, et al., 1955).

Infection is transmitted by the fecal-oral route. The organism may be present in enormous numbers in the feces of clinically ill persons, but it can also be spread by asymptomatic carriers as well as convalescents. Shigella has been isolated from clothing, toilet seats, and contaminated food; and flies are known to carry and spread infective material. Infection with Shigella occurs endemically in most communities and may be maintained by a few symptomless carriers in the absence of clinical cases.

Bacillary dysentery occurs most commonly during summer months in tropical countries where lower standards of hygiene increase opportunities for transmission by many routes. Many different serotypes generally are present in these areas with no single one playing a much greater role than any of the others. Water supplies in tropical countries tend to receive shigellae that are water-washed from many sources, whereas in developed countries, transmission by water is most often the result of contamination from one identifiable source. Stricter sanitation measures, proper sewage disposal, and public health standards enforced in the developed countries have led to a shift in peak incidence from summer to winter, as low temperatures favor survival of Shigella. One species, S. sonnei, predominates, probably because it can survive longer under adverse conditions (Feachem, 1977).

In the U.S., waterborne outbreaks of shigellosis have increased somewhat from 1961 to 1977, although shigellae are not often isolated from water and the organism poses no unique problems to the protection of water supplies. The majority of outbreaks were from inadequately maintained and monitored semi-public systems, especially those serving recreational areas that are in use for only part of the year. Fecal contamination and improper disinfection of a well, situated approximately 46 m (150 feet) from a septic tank, were blamed for an outbreak of shigellosis in Florida (U.S.) involving 1,200 people (reviewed by Craun, 1977). Thermo-tolerant coliforms were isolated from drinking water after 690 people became ill with shigellosis during passage aboard a cruise ship sailing from the U.S. The water was found to have been stored improperly and not given sufficient contact time with the chlorine disinfectant. (Reviewed by Hughes and Merson, 1975). An outbreak involving hundreds of cases occurred in 1977, in Germany, when a reservoir was contaminated with waste from a nearby water-flush toilet (Bohm, et al., 1978). These incidences serve to underscore that the lesson still to be learned in developed countries is that of increased vigilance, especially in connection with semi-public water supplies.

As with Salmonella, no standardized procedures have been established for isolating Shigella from water. Tentative methods, subject to modification, are offered in Standard Methods (American Public Health Assoc., 1975) and elsewhere. Concentration techniques described in Standard Methods are the same as those for Salmonella [See Section III.B.1.a(i)]. GN broth affords good enrichment for



Shigella while suppressing coliforms and fecal streptococci. The formulation includes dextrose and d-mannitol which are balanced to limit the growth of Proteus and encourage that of enteric pathogens. High concentrations of sodium citrate and sodium desoxycholate inhibit gram-positive organisms, and the latter ingredient is far less toxic to Shigella than brilliant green dye which is unacceptable for use with Shigella. Xylose lysine desoxycholate agar is a differential media suggested by Standard Methods for isolation of Shigella species when used in conjunction with GN enrichment broth. Finally, suspect colonies can be purified and subjected to various biochemical and serological procedures.

(iii) Yersinia Enterocolitica. Evidence of infections due to Yersinia enterocolitica has been mounting since the early 1960's, especially from the world's cold or temperate regions. Illness caused by this organism has been reported in recent years from North America, Japan, South Africa, and almost every European country. Some cases also have been noted in South America, North Africa, and the Middle East; and the disease probably would be found common in many other parts of the world if there were more laboratories in these areas capable of detecting the causative organism (Alonso, et al., 1976; Bottone, 1977; Toma and LaFleur, 1974).

(iii.1) Characterization of Y. Enterocolitica. The organisms comprising the genus Yersinia (Y. pestis, Y. pseudotuberculosis, and Y. enterocolitica), of the family Enterobacteriaceae, were formerly considered members of the genus Pasteurella. Although no consensus on the precise definition of Y. enterocolitica has been reached, it is described in general terms as a gram-negative, facultatively anaerobic, motile (below 30°C) coccobacillus. Mollaret and Thal (Buchanan and Gibbons, 1974) provide some biochemical differentiations among the three species. Y. enterocolitica has been divided into many serobio-, and phage-types; and these have all been classified into three or four groups based on DNA homology (Brenner, et al., 1976). However, it is more likely that this wide spectrum of types eventually will be separated into different, more precisely defined species. The most noteworthy characteristic of this bacterium is its stability and even growth down to temperatures as low as 4°C (optimum, 20°C) [See Section B.3.c]. Yersiniosis, caused by both Y. enterocolitica and Y. pseudotuberculosis, is thought to be contracted perorally; its appendicitis, mesenteric lymphadenitis, or acute terminal

ileitis. Y. enterocolitica has been isolated from lymph nodes and feces of both sick and healthy humans along with a growing number of animal species. Though there are human and animal carriers, their role in the disease's transmission is as yet undetermined.

(iii.2) Sources and Occurrence of Y. Enterocolitica. Broadly speaking, the organisms that are classified Y. enterocolitica fall into two main groups (Mollaret, 1976). The first group causes typical illnesses and consists of host-specific strains with constant and stable bio-, sero-, and phage types. Predominant types within this group may differ from place to place suggesting that incidences of the disease in different areas of the world may have no epidemiological connection. For example, in Japan, Canada, and most European and African countries, serotype 0:3 predominates. However, strains of this serotype belong to phage type 8 in Europe and Japan; whereas in South Africa, these strains are classified as phage type 8 or 9a; and phage type 9b is regarded as the "specific Canadian" type elaborated by these strains (reviewed by Toma and LaFleur, 1974). The serotype 0:9 predominates in Finland and serotype 0:8, which predominates in the U.S., does not occur at all in Europe.

Sources of the infection have remained largely unknown. The human serotype 0:3 has been found to occur in animals (including pigs and household pets) suggesting a zoonotic epidemiology; however, no clear connection between human and animal infections has ever been established. In fact, there is reason to believe that Y. enterocolitica infections occur independently in humans and animals as a result of exposure to an environmental source common to both (Mollaret, 1976).

Little has been written about the second group whose occurrence and significance in different ecosystems is not well understood. Strains of this group have been isolated from small mammals (Kapperud, 1977), poikilotherms (Kapperud and Jonsson, 1976), water (Harvey, et al., 1976), and food (Morris and Feeley, 1976). They do not appear to require a specific host and they vary widely in biochemical and antigenic characteristics. Humans and animals can carry them with no clinical symptoms (Mollaret, 1976).

Different Y. enterocolitica types have been isolated so frequently from untreated surface water in some areas that they most likely represent part of the normal microbial flora of the water and surrounding terrestrial environments

(Kapperud, 1977). Alternately, the same Y. enterocolitica biotype and/or serotype is readily recoverable in these areas from a wide range of animal species (including poikilotherms) indicating a nonspecific role in these ecosystems. Most of these organisms belong to the rather ill-defined second group and generally do not appear to act as pathogens. Although members of this group also have been isolated occasionally from people with diarrhea (Kapperud, 1977; Toma, 1973), their presence is probably only incidental.

(iii.3) Epidemiology of Waterborne Y. Enterocolitica Infections. Reports referring to waterborne Y. enterocolitica infections are few in number. Lassen (1972) described a case of violent gastroenteritis caused by Y. enterocolitica serotype 0:13-7 in an 18 year-old woman. This same sero- and biotype had been isolated only a few days earlier from the well next to her house. Keet (1974) reported a septicemia in a 75 year old man from Y. enterocolitica serotype 0:8, in which the source of infection was later traced to a mountain stream. He postulated that wild animals inhabiting a watershed may transmit the disease indirectly through the water to farm or domestic animals. In December 1975, waterborne gastroenteritis occurred in 41% of approximately 1,500 guests at a ski resort in Montana (U.S.). Although Y. enterocolitica was isolated from the unchlorinated well water, what, if any, role it played in the outbreak remains unclear (Center for Disease Control, 1975a).

It has been proposed that, to infect humans, Y. enterocolitica may require an intermediate period of multiplication at reduced temperatures (after passage through a vector) wherein the organism can reach infective levels. Such a "hot-cold" mode of transmission could account for the observed increase in cases of yersiniosis in colder climates and seasons (Bottone, 1977). Moreover, Y. enterocolitica grown at 37°C is less resistant to normal cellular bactericidal defenses than when grown at 20°C (Nilehn, 1973); this could explain why infection through direct person-to-person contact is relatively rare, and again, why an intermediate cold phase could be critical to its spread. If so, the life cycle for Y. enterocolitica would stand in sharp contrast to that of others in the family Enterobacteriaceae whose ability to be transmitted through water represents only an exceptional phenomenon.

There is no standard method for the isolation and enumeration of Y. enterocolitica in water. This microorganism is similar to other enteric bacteria except that it grows better at 25°C than at 36°C, and it is able to grow at

4°C. For these reasons, a procedure analogous to those for food examination has been proposed. This method described recently by Highsmith and coworkers (1977b) includes: membrane filtration; liquid enrichment in M-Endo broth at 25°C and 36°C for 72 h and plating on Salmonella-Shigella (SS) or MacConkey agar at 4°C for 14 to 21 days; isolation on the same plating media or enrichment broth and incubation at 25°C; biochemical identification of the lactose-negative colonies on Triple Sugar Iron agar for urea and motility determinations before further identification and typing.

(iv) Enteropathogenic Escherichia Coli. Transmission of enteropathogenic E. coli through drinking water was frequently reported during the 1950's (Monnet, et al., 1954; Seigneurin, et al., 1955; and Lanyi, et al., 1959).

Certain enteropathogenic strains of E. coli are now known to cause acute diarrhea, especially in infants, in travelers to foreign countries, and in consumers of contaminated foods. These organisms include 14 distinct antigenic types, in addition to other recently implicated strains, some of which are not serologically typable.

Disease may occur by either of (at least) two mechanisms: tissue invasion or toxin production. When cells penetrate the intestinal epithelium, the result is a syndrome like the bacillary dysentery caused by virulent Shigella strains. The second mechanism entails the production of potent heat-labile or heat-stable enterotoxins which induce cholera-like symptoms or a salmonellosis-like enteritis. If the organism colonizes the upper bowel it will manifest enterotoxigenicity; but, it may be carried in the colon without producing any harmful effects. However, because toxin production is a plasmid-borne trait, organisms of a given serotype may or may not be toxigenic.

Of the 99 waterborne outbreaks of gastroenteritis reported in the U.S. from 1971 to 1974, no causal agent was identified in almost half of these incidents. The extent to which enteropathogenic E. coli was involved in these outbreaks is largely unknown, primarily because serotyping of isolates is not routinely performed during outbreaks.

Two of the best documented outbreaks took place in Sweden in the autumn of 1965, one in a residential area of Uppsala, and the other in the small community of Gimo situated 50 kilometers north of Uppsala (Danielsson, et al., 1968).

Within a period of 14 days, 442 residents of Uppsala fell ill; 261 of them experienced the onset of symptoms during a two day peak. High coliform densities were discovered in the community's water supply. A rapid (2 to 8 h) preliminary screening technique, based on membrane filtration combined with fluorescent antibody staining (Danielsson, et al., 1968), was applied to water samples and identified three serotypes of enteropathogenic E. coli. Freshly collected water samples and enriched water samples (incubated at 37°C for 4, 6, and 14 h in nutrient broth) were filtered or centrifuged, and filter sections or sediment smears were stained with fluorescent antibody. In conjunction with this, fecal specimens from sick patients were serotyped according to conventional culture and serological procedures. Both water samples and fecal specimens were found to contain the same three serotypes 026:B6, 0128:B12, and 0111:B4 -- the latter serotype predominated in both fecal and water sources.

Only a few cases of gastroenteritis were reported for the community of Gimo, although the drinking water supply was also found to be highly contaminated with coliforms after a spell of heavy rains. Serotypes 026:B6, 0114:B?, and 0125:B15 were identified from samples subjected to Danielsson's membrane filtration and fluorescent staining technique. However, since no clinical specimens were collected for bacteriological examination, etiology could not be confirmed. Danielsson and coworkers (1968) cautioned that their rapid screening technique could yield false positive results due to serological cross reactions with other bacteria, and they advised that conventional methods be used for confirmation.

A large waterborne outbreak of illness caused by enterotoxigenic E. coli occurred in June and July of 1975, at Crater Lake National Park, U.S.A. (Rosenberg, et al., 1977). More than 200 staff members and 2,000 visitors to the park experienced prolonged diarrhea, cramps, nausea, and vomiting. Telephone surveys and questionnaires strongly associated the illness with ingestion of the park's drinking water, supplied by a shallow spring. The water supply, although chlorinated before distribution, was not routinely monitored for chlorine residuals once it had entered the distribution system. Later tests, using fluorescein dye, revealed that raw sewage from an overflowing manhole was contaminating the water.

Lactose-positive and -negative colonies, picked from cultured stool specimens, were tested for toxin production

using mouse adrenal tumor cell, Chinese hamster ovary tissue culture, and infant mouse assays (Rosenberg, et al., 1977). Of 120 patients examined, enterotoxigenic E. coli (exclusively serotype 06:H16) was isolated from 20 of them. The organism produced both heat-labile and heat-stable toxins. No Salmonella, Shigella, pathogenic vibrios, or Yersinia enterocolitica were recovered from either the spring water or from clinical specimens.

These investigators pointed out the relative insensitivity of current culture methods. They explained that the lack of recovery of enterotoxigenic E. coli from many fecal specimens was, in all probability, due to the pathogen's short duration (averaging less than four days) after diarrhea had ceased. Also criticized was the practice of testing only five to ten E. coli isolates randomly chosen from nonselective media. The serum antitoxin immunity test was held to work well only in areas where a particular pathogen, such as cholera, is endemic and/or introduced at high antigenic levels. This was not the case with the Crater Lake outbreak. The authors recommended intensive screening of a substantial portion of diarrheal fecal specimens for presence of the enteropathogenic agent. Once a predominant serotype of E. coli was shown to be enterotoxigenic by criteria listed earlier, the remainder of fecal specimens would then be tested serologically for the presence of that strain.

The definition of the coliform group includes E. coli, so enteropathogenic E. coli is unlikely to be present in water in which coliforms are undetectable; this relationship is far more direct than is usual between indicators and pathogens. However, even if E. coli is shown to be present, its enteropathogenicity can be determined only by highly refined techniques. The presence of enteropathogenic E. coli is not a great deal easier to monitor than that of several pathogens, including viruses, which may cause waterborne outbreaks of acute diarrhea.

(v). Francisella Tularensis. Tularemia is a zoonotic disease, transmitted to humans from blood-sucking arthropods, domestic animals, and primarily by a number of wild animal species, many of which lead semi-aquatic lives. It is this semi-aquatic existence of such susceptible hosts as voles, beavers, muskrats, and water voles that accounts for most waterborne outbreaks of the disease in humans. Tularemia is endemic on three, possibly four, continents and is ubiquitous throughout the northern hemisphere, including North America,

Europe (except the British Isles, Spain, and Portugal), the U.S.S.R., Turkey, and Japan (Hopla, 1974).

The causative agent, Francisella tularensis, is described as a tiny gram-negative, aerobic, singly occurring, non-motile, nonencapsulated, nonsporulating, bipolar rod requiring special media to which glucose and cysteine or cystine have been added. Historically, it has occupied several generic designations -- these being Bacterium, Bacillus, Brucella, and Pasteurella. But, the organism was finally placed in a genus by itself, Francisella, based on its small size and because it does not grow on simple nutrient media. Nonetheless, investigators in the U.K. generally refer to this pathogen as Brucella tularensis because of cross-reactions with agglutinating antigens of the genus Brucella. F. tularensis is killed by heating for 30 minutes at 50°C, but it can survive over three weeks at -14°C or after desiccation.

The disease occurs as an anginose-bubonic infection when contracted through ingestion (as opposed to inhalation or skin contact with animals), producing buboes and areas of necrosis in organs and tissues of man and animals.

It was first suggested that tularemia was transmissible through water in 1935 (Pollitzer, 1967). The first reported outbreak of waterborne tularemia, in which 45 people, all of whom drank from a small stream where F. tularensis was later isolated, came down with the disease was documented in 1936. Lesions observed on the mucosa of the tonsils and the oral cavity implicated water as the vehicle.

Most references to waterborne tularemia are integrated into a very extensive body of tularemia literature contributed by Russian workers in response to a series of explosive tularemia outbreaks which ravaged the U.S.S.R. in 1928 and over the next 30 years. Several investigators have directed their studies to the westward penetration of tularemia in Eastern Europe during and immediately after the Second World War. The disease had calamitous effects on the Soviet army beginning in 1941 and was traced to drinking water contaminated with rodent carcasses and excrement as a vehicle of infection.

Outbreaks of waterborne tularemia have been reported throughout the U.S.S.R. Leningrad was struck with about 200 cases in 1944 - 1945 of which 20 percent were shown to be waterborne (Pollitzer, 1967). Drinking water contaminated with infected rodent carcasses accounted for 22.8 percent of tularemia cases in White Russia (Pollitzer, 1967). Three river cities in Central and Eastern Siberia experienced

tularemia epidemics in the 1940's in which contaminated drinking water played an important role second only to that of insect and tick bites. It appeared that a peak in the epidemic was reached during the warmer months of June to September. Cases of waterborne tularemia have been reported for the southern part of the U.S.S.R., notably Armenia and Kazakhstan, where the anginosebubonic form of the disease was greatly in evidence. Investigation of outbreaks in Kazakhstan placed the blame on direct or indirect contact with water rats. The Altai Mountain region was also hit with tularemia in 1955 through 1957, reportedly from drinking water contamination (Pollitzer, 1967).

Recent cases of waterborne tularemia in northern Norway have brought about renewed interest in water as a vehicle of infection in the Scandinavian peninsula. Mair (1973) studied a series of what he termed otolaryngological manifestations of the disease involving hunters who drank from a mountain brook during a period of peak rodent (notably lemmings) populations. Short-term contamination of rural streams is the more common, well documented source of waterborne tularemia outbreaks, and is attributed to epizootics among semi-aquatic wildlife, mainly voles, beavers, muskrats, and water voles.

There is no standardized method for the examination of water for *F. tularensis*. The genus is characterized by growth requirements for cysteine or cystine; no growth is obtained on ordinary culture media. Semi-solid media which allow for slow growth, such as gelatinized egg yolk and media containing cysteine, glucose, and defibrinated rabbit blood (or serum) can be used. Identification is accomplished by means of biochemical tests.

(vi) Leptospira. The genus Leptospira is composed of finely coiled, spiral organisms including a number of strains that cause leptospirosis in humans and many animals. The organisms are of slender appearance, have numerous coils with bent or hooked ends, and are very actively motile. They do not stain well in conventional stains, but require special preparations.

At present, all leptospirae are grouped within one species, L. interrogans. L. interrogans is divided into two complexes: 1) interrogans, all strains that are pathogenic or parasitic; and 2) biflexa, free-living or water leptospirae that commonly occur in fresh surface waters. The



interrogans complex contains 18 serogroups and about 150 serotypes. The most important serogroups are: Ictero-haemorrhagiae, Canicola, Hebdomadis, Pomona, Grippotyphosa, Autumnalis, Australis, Mitis, and Bataviae. More detailed studies are available (Fuchs and Burger, 1974). It was proposed in 1973 by the Leptospira subcommittee that these complexes be designated species: L. interrogans and L. biflexa.

Leptospirae can be grown on various media containing peptone and inactivated serum. They are aerobic, their optimal temperature is 28 to 30°C, and they grow well at pH 7.2 and 7.4. Reliable diagnostic methods are available, and most laboratories are equipped to distinguish leptospirosis from other diseases as well as to identify the specific serogroup responsible.

The leptospirae penetrate the surface epithelium of the host and enter the bloodstream, where they multiply and are carried to all organs of the body (hence, the diversity of symptoms). They finally settle in the convoluted tubules of the kidney and from there are excreted in the urine. Incubation time of the disease is usually from seven to 13 days. Symptoms may range from fever, headache, chills, malaise, vomiting, and muscular aches to very severe and even fatal illness including meningitis, encephalitis, haemorrhagic states, and infrequently, jaundice. Symptoms formerly ascribed to Weil's disease may be caused by all the pathogenic strains, depending on the virulence of the strain and on the reaction of the host. Severe cases may have fatality rates of as high as 50 percent (Turner, 1973).

The leptospirae are not particularly heat-resistant (Chang, et al., 1948) and are killed in 10 min at a temperature of 50°C. They are sensitive to desiccation, acid (such as gastric juice), and to disinfectants; and they are destroyed by bile. They do not tolerate high salt levels and are soon eliminated in polluted water or sewage. They can, however, withstand freezing for some time.

Leptospirosis is essentially a zoonosis that can occur in great numbers of domestic and wild animals depending on climate and availability of a food supply. The organism is maintained in the environment by both carrier and diseased hosts, and transmission is particularly favored by population explosions of animal carriers, especially rats. In temperate regions, animal hosts most likely to transmit disease to man are rats, dogs, and swine. Human exposure to

the disease has been from direct or indirect contact with urine from infected animals (Kathe, 1945; Müller, 1969a). Humans are considered to be a dead-end host, as person-to-person spread is rare. Mild anicteric forms are now recognized as more common than clinically severe icteric forms of the disease; consequently, human infection with pathogenic leptospirae may pass completely unnoticed.

In the U.S., the most likely sources of infection with Leptospira are surface water, dogs, rodents, cattle, and swine (Reasoner, 1977). However, infection by the water route is mainly the result of swimming in polluted ponds or creeks; or, in the case of miners, of walking through stagnant water infested with rodents. Warm ( $\sim 22^{\circ}\text{C}$ ), slow moving streams of neutral or slightly alkaline pH provide an ideal environment that can prolong Leptospira survival for many weeks. Infection with Leptospira is primarily associated with certain occupations such as mining, dairy farming, and sanitary engineering. Only rarely is it associated with drinking water (Heath, et al., 1965), as in times of disaster such as during wars, when there has been a breakdown in sanitation and public health systems. In post-war Berlin, the incidence of the infection was very high (Becker, 1969).

The detection of Leptospira is made difficult by the competitive growth of other organisms and the need to differentiate between pathogenic and saprophytic strains. There is no standard method for isolating Leptospira from environmental sources, but a tentative procedure entails analysis of bottom sediments by concentration, enrichment in Fletcher's semi-solid medium containing 10 percent rabbit serum, and incubation at  $30^{\circ}\text{C}$  for six weeks. During incubation, the medium should be checked repeatedly for the appearance of leptospirae and for any culture contamination. Upon detection, the Leptospira isolates must be further characterized by various biochemical and serological tests (American Public Health Assoc., 1975).

(vii) Vibrio Cholerae. The genus Vibrio comprises a large number of species, only a few of which are of medical importance: V. cholerae and its biotype V. cholerae El Tor cause cholera exclusively in man; V. parahaemolyticus (a marine organism which typically inhabits estuaries); and nonagglutinable (NAG) vibrios can cause cholera-like disease or mild diarrhea in humans (Heiberg, 1935), but are not normally transmitted by the water route. Only under exceptional circumstances (e.g., contamination with surface water

due to leakage or cross-connections) can NAG vibrios be transmitted through drinking water. However, numbers sufficient to cause illness ( $10^5$ ) are obtained only after subsequent enrichment in food (Muller, 1977a).

The genus is composed of polymorphic, gram-negative, nonsporeforming rods that are slightly curved, actively motile, and that possess a single thick polar flagellum. They are not fastidious and grow readily on a number of simple media which need only contain a balanced mixture of utilizable carbohydrate, inorganic nitrogen, sulfur and phosphorous sources, simple minerals, and an adequate buffer. Vibrios grow best between 30 and 40°C and at a pH near neutrality. They are classified according to their biochemical reactions in tests that include slide hemagglutination, Voges-Proskauer test, polymyxin-B sensitivity, and resistance or susceptibility to Mukerjee's group IV cholera phage (Finkelstein, 1973; Wilson and Miles, 1975). Two major serotypes, Ogawa and Inaba, and one rarely encountered serotype, Hikojima, are recognized in both V. cholerae and the El Tor biotype.

The vibrios are sensitive to heat, sunlight, and drying; and they are especially intolerant of acid but are able to withstand alkalinity up to pH 10.2. They survive well at low temperatures and can persist for weeks in cool, pure drinking water. The El Tor biotype seems hardier than the classical Vibrio biotypes and can survive longer in nature (Finkelstein, 1973).

Cholera, whether caused by classical V. cholerae biotypes or the El Tor biotype, produces the same clinical symptoms of profuse diarrhea, leading to rapid loss of fluid together with loss of bicarbonate, sodium, potassium, and chloride ions. In severe cases, this can be accompanied by a drop in body temperature and blood pressure, followed by prostration, kidney failure, and death. Untreated case fatalities are over 60 percent, but death always can be averted by early medical intervention. The time of incubation is anywhere from a few hours to six days. Infection is confined to the gastrointestinal tract, and formation of enterotoxin is what triggers host response. Diagnostic procedures are standardized throughout the world, and laboratories can easily identify the disease if alerted to the possibility of cholera and suitably equipped.

Fecally contaminated water is the primary vehicle of cholera transmission, although vibrios are also spread by a

multitude of other routes including food, soiled clothing, flies, and direct person-to-person contact. Extremely high numbers of cholera vibrios can be found in human feces and vomitus. The disease has a high rate of secondary spread when there is contact with sick individuals who shed the organism in enormous numbers, particularly during the first days of illness. Generally, the number of inapparent infections or mild cases greatly exceeds that of severe cases by a factor of ten up to several hundred. Major determinants of this ratio are levels of hygiene and nutrition, occurrence of other enteric infections (which can permit vibrios to pass unharmed through the gastric juices), and quantity of vibrios ingested [See Section B.4]. The carrier status is presumed to be transitory; but, especially in patients over 50 years of age, prolonged infection in the gall bladder has caused chronic and intermittent shedding (Zwadyk, 1976).

Cholera is still one of the most severe and contagious of infections, having spread to over 171,000 people in 42 countries since 1961. In 1971, it became clear that the El Tor biotype was responsible for this seventh recorded cholera pandemic. The agent has been widely disseminated due to a high frequency of unrecognized El Tor infections. The disease has characteristically been sporadic and endemic in areas of poor hygiene and warm humid climates (Barua, 1970; Feachem, 1977; Felsenfeld, 1967; and Mosley, 1970). However, isolated cases have been reported in Czechoslovakia, Spain, France, Portugal, Australia, New Zealand, Sweden, the U.K., and the U.S., mainly from importation through tourism (Finkelstein, 1973).

Crabs caught in a Louisiana (U.S.) lake caused six known cases of cholera in 1978 (Center for Disease Control, 1978c). Water sampled from the lake and from sewage of a nearby town showed presence of the Inaba serotype as did clinical specimens from patients. Except for these and a single case in Texas, the U.S. has had no reported cases of cholera since 1911.

During the last century, when standards of hygiene were lower, Europe suffered from several devastating epidemics. However, it is now well understood that the spread of cholera can be arrested quickly and entirely by adequate sewage and water treatment, together with prompt detection and treatment of cases and carriers. Moreover, a healthy and well nourished population is unlikely to succumb to infection with V. cholerae, particularly that caused by the El Tor biotype.

Methods for isolating vibrios from water have not been standardized. Sampling procedures have included the use of membrane filters, gauze pads, and grab devices. Enrichment in alkaline peptone water at pH 8.4 or in taurocholate tellurite peptone water at pH 9.2 yielded good results after incubation initially for 4 to 6 h at ambient temperatures ( $\approx 25^{\circ}\text{C}$ ) and then for 18 h at  $37^{\circ}\text{C}$  (Colwell and Kaper, 1977). Enrichment cultures were streaked onto TCBS agar and suspect colonies were screened by testing for presence of oxidase. Further differentiation was achieved by biochemical and serological testing.

(viii) Campylobacter. Campylobacter is a small, gram-negative, curved or spiral-shaped rod possessing a long, single polar flagellum at one or both ends of the cell. It has a characteristic corkscrew type of motility, is micro-aerophilic, and grows easily on a conventional culture medium at  $37^{\circ}\text{C}$  in a special atmosphere of 5 percent oxygen, 10 percent carbon dioxide, and 85 percent nitrogen (Smibert, 1978). Included in this genus are pathogens for both humans and animals as well as saprophytic forms normally occurring in the oral cavity, reproductive organs, and intestinal tract.

The organism was initially observed as the agent of infectious abortion in cattle and was named Vibrio fetus. However, because its G + C content is much lower than that of members of the genus Vibrio, and because it does not ferment or oxidize carbohydrates, V. fetus has been reclassified as Campylobacter fetus. Of the three species -- C. fetus, C. sputorum, and C. fecalis -- only C. fetus is pathogenic for man.

In addition to causing abortion and sterility in cattle and sheep, C. fetus ss. jejuni and intestinalis also may cause gastroenteritis in humans, cattle, sheep, and swine. Human infections with Campylobacter can lead to gastrointestinal disease characterized by abdominal pains, diarrhea, malaise, headache, and fever lasting from one to four days. All age groups and both sexes appear to be equally susceptible to infection. The organism inhabits the genitourinary and intestinal tracts and is excreted in the feces.

In several studies, Campylobacter was isolated from stools of 4 to 8 percent of patients with diarrhea -- an isolation rate comparable to those of the more commonly recognized enteric pathogens such as Salmonella [See Section

B.1.a(i)] and Shigella [See Section B.1.a(ii)] (Butzler, et al., 1973; Skirrow, 1977; Steel and McDermotts, 1978; and Pai, et al., 1979). Campylobacterial gastroenteritis with diarrhœa has been described in Rwanda (Africa) (De Mol and Bosmans, 1978), Canada (Laboratory Centre for Disease Control, 1978), and the U.S. (Center for Disease Control, 1978).

Feces from infected humans, animals, and fowl may contaminate surface waters destined to be used for drinking water supplies. If such source waters were inadequately treated, viable Campylobacter cells could theoretically gain entry to finished water. The exact mode of transmission to humans is unknown, but contaminated food and water probably serve as major vehicles (Joklik and Willett, 1976).

The best evidence for waterborne transmission of this organism to humans came from an outbreak in Bennington, Vermont (U.S.) (Center for Disease Control, 1978b). During two weeks in May 1978, 2,000 of the town's 10,000 residents became ill with gastroenteritis. An epidemiologic investigation showed a strong association between gastroenteritis and consumption of water from the town supply. C. fetus ss. jejuni was isolated from individuals with diarrhœa by culturing fecal samples obtained from rectal swabs. In this case, water samples taken from several areas of the town showed no residual chlorine. The report went on to state that investigators were seeking evidence for contamination from wild and domestic animals within the watershed.

Prior to the Bennington outbreak, isolation of this pathogen was occasionally successful only if blood from an infected individual was cultured (King, 1962). Later, a procedure for isolating Campylobacter from stools was described by Butzler and coworkers (1973). Also, a selective growth medium containing vancomycin, polymyxin B, and trimethoprim was described in England by Skirrow (1977). Both media require incubation at 43°C and microaerophilic culture conditions. Failure to isolate Campylobacter is more often the result of improper atmospheric adjustment than an incorrect choice of growth media. The organism also has been grown using Albimi Brucella broth (Pfizer Diagnostics, Flushing, N.Y.), supplemented with 10 percent animal blood. This formulation is used either as a semi-solid broth (0.16 percent agar) or a solid medium. Because it is microaerophilic, Campylobacter will grow only within the upper first few millimeters of a semi-solid growth medium.

At present, there are no standard methods for detecting Campylobacter in water. When such methods become available

for routine use, it will then be possible to determine the significance of Campylobacter in water as it relates to outbreaks of waterborne gastroenteritis.

(ix) Opportunistic Pathogens. Several other microorganisms present in water can cause disease infrequently, and almost always under unusual circumstances, either in abnormal hosts or in situations where the normal flora have been supplanted. These organisms are called opportunistic pathogens and are ubiquitous in nature, very resistant in water, can grow with only a few nutritional requirements, and are able to accept and transfer plasmids which carry the determinants for resistance to antibiotics. Concentrations of opportunistic pathogens found in drinking water are not normally sufficient to lead to infection in a healthy consumer.

The endotoxins produced by these agents, however, pose a significant health hazard to the hospitalized, immunodepressed patient who might suffer from septicemia, wound infection, urinary infection, or be in an otherwise weakened state. Also susceptible are post-operative patients, individuals being treated with immunosuppressive or antineoplastic agents, cancer or leukemia patients, newborn babies (especially when premature), and the very old and infirm.

The organisms are most frequently transmitted by contact with material, water, disinfectants, cleansing fluids, or via intravenous therapy; airborne spread occurs less frequently. These modes of transmission are to be distinguished from the definite possibility of self-infection, whereby the host, being in a weakened state, may become susceptible to the growth of an organism that is already present in the body in low numbers. Of all hospitalized patients, 5 to 18 percent can be expected to have contracted an infection from opportunistic pathogens; the risk is higher in hospital wards using more technical equipment, for example, in emergency care or neurosurgery.

The dangers resulting from bacterial metabolites, such as pyrogens, should not be overlooked; and problems caused by these organisms may extend to households and to scientific laboratories, where de-ionizer and soft water units have been shown to contain gram-negative bacteria. Opportunistic pathogens also have been found growing in humidifiers and ventilation plants.

Opportunistic pathogens whose presence in water can be anticipated include the following bacteria:

- Pseudomonas species, especially P. aeruginosa, present special problems in stored water and with medical procedures and equipment that use water, such as dialysis units, water baths, sprinkler heads, scrub sinks, and others (to be discussed further at the end of this section).
- Aeromonas hydrophila has been found in feces from healthy individuals and those suffering from diarrhea, in domestic animal feces, and in drinking water (Annapurna and Sanyal, 1977). This bacterium has drawn increased attention recently because of its ability to cause infection in man, animals, fish, and reptiles, and because it produces enterotoxins. Antibiotic-resistant species of Aeromonas, including A. hydrophila, not commonly identified as agents of human infection (but rather of certain species of fish and frogs), have been transmitted to humans via source water receiving wastewater and have caused cases of acute cellulitis (Hanson, et al., 1977). Populations of this organism in numbers as high as  $10^5$  to  $10^6$  cells per ml have been found in aquatic environments which receive wastewater.
- Edwardsiella tarda has been isolated from human patients and is associated with gastroenteritis. It is harbored in the intestines and can cause septicemia (Koshi and Lalitha, 1976).
- Flavobacterium can cause meningitis, bacteremia, or septicemia. It is composed of a variety of species, some of which tolerate high levels of chlorine, are resistant to antibiotics, and can produce pyrogenic metabolites (Colwell, et al., 1978).
- The genera Klebsiella [See Section III.C.2.d], Enterobacter, and Serratia of the tribe Klebsiellae have been recovered from human feces and water. They are able to grow in water, are often resistant to antibiotics, and can cause urinary infections or septicemia.



- The genera Proteus and Providencia of the tribe Proteae can infect the urinary tract and cause bacteremia in debilitated patients. They are found in the feces or urine of infected individuals.
- Citrobacter and Acinetobacter can cause infections of the digestive tract or produce bacteremia or septicemia in debilitated persons.

Staphylococcus aureus, Bacillus cereus, and Clostridium species are unable to multiply in water, but can cause illness (notably diarrhea) after incubation and growth in food to which contaminated water was added.

P. aeruginosa has received the greatest attention in its role as an opportunistic pathogen and also was the first organism to be described as such. Pseudomonas species (pseudomonads) are gram-negative bacilli, straight or curved, and are motile with polar flagella. They are strictly aerobic, but denitrifying species do exist. They are chemoorganotrophs and some are facultative chemolithotrophs [See also Section A].

P. aeruginosa is a bacillus of 1 to 3  $\mu\text{m}$  in length and 0.4  $\mu\text{m}$  in diameter, with a polar flagellum. It is ubiquitous in nature and may actively reproduce in potable and distilled water to populations as high as  $10^7$  per ml (Carson, et al., 1975). This bacterium has few requirements and can grow with only carbon as its energy source in a broad range of temperatures (4 to 42°C) and pH (5 to 8). P. aeruginosa is ordinarily a strict aerobe but can grow under anaerobiosis, utilizing nitrates or arginine as electron acceptors. The identification of P. aeruginosa includes determining its production of pyocyanin on King's medium and some biochemical characteristics, for example, as proposed by Brodsky and Cieben (1978). Strains can be differentiated on the bases of the antigens and pyocyanins that they produce, as well as by phage typing.

P. aeruginosa can cause illness, especially in immunodepressed patients. Ingestion or contact with large amounts of P. aeruginosa in water can cause enteric, eye, ear, and upper respiratory tract infections. The enteric infections are most often manifested as stomach upsets and nausea, but they are not usually reported to medical practitioners. To

become infected, a consumer must be weak (very young or old or immunodepressed) and ingest an effective dose (Hunter, 1947). The eye, ear, and upper respiratory tract infections often cause relatively long-term symptoms, as reported by Hoadley (1977).

A very important problem associated with P. aeruginosa is its increasing resistance to antibiotics (Van Dijck and Van der Vorde, 1976). This resistance is extrachromosomal and the plasmid can code for multiple resistances (Leclerc, et al., 1977a). These plasmids can be passed to the human enteric bacilli that occur with P. aeruginosa in water. P. aeruginosa can also be very resistant to antiseptics.

Even though the pathogenicity of P. aeruginosa is determined more by the patient's state of resistance than by any inherent virulence, the possibility of creating conditions for this microorganism to proliferate in distribution and plumbing systems must be considered. About 10 percent of the healthy human population are carriers and can eliminate P. aeruginosa in feces (Hugh and Gilardi, 1974). This organism can survive in raw water and can be present in drinking water with a frequency varying from 1 or 2 percent to more than 50 percent, depending on the quality of the water (potable or not potable) and the type of water treatment practiced. P. aeruginosa may also persist and grow in water for extended periods and so is frequently found in the absence of coliforms; one study reported that half of the finished water samples containing P. aeruginosa lacked coliform bacteria (Nemedi and Lany, 1971).

For all these reasons, consideration should be given to possible incorporation into routine drinking water analyses of tests for the presence of P. aeruginosa [See Sections F.2 to 3 and G.6], since suitable methods exist for its enumeration [See Section C.2.c].

b. Viruses. Viruses are ultramicroscopic intracellular parasites, incapable of replication outside of a host organism. They consist of a nucleic acid genome enclosed in a protective protein coat and some viruses have lipid-containing outer envelopes. They have been classified on the basis of their size and shape, the composition of their nucleic acid (single or double stranded DNA or RNA), and by their antigenic properties.

Large numbers and diversities of bacterial, plant, and animal viruses may be present in both polluted and unpolluted waters. Most of these viruses are harmless to humans;

they may, however, be economically damaging to agriculture and certain industries such as breweries and dairies.

The viruses of greatest concern are those of human origin which are capable of infecting and causing disease in humans. In general, they are shed in the feces and are known as the human enteric viruses. The most important groups of human enteric viruses will be discussed below. The virus particles (virions) in all these groups are roughly spherical, acid-stable, and lack envelopes [See Table B.1.b-1]. These viruses may cause symptoms in the digestive tract (vomiting and diarrhea), generalized symptoms such as fever, and occasionally respiratory illnesses; some of the more virulent enteric viruses may affect the central nervous system (meningitis or poliomyelitis) or the liver.

(i) Pathogenesis of Viruses. Infectivity resides in the nucleic acid portion of the virus particle. When a suspension of infectious particles is inoculated into a culture of susceptible cells, the particles are engulfed by, or penetrate, host cells, and the cells produce progeny virus. Death of the host cells often results as the viruses continue to replicate.

Infection usually takes place after viruses are ingested, possibly in contaminated water or food. They can pass unharmed through the stomach and infect cells lining the lower alimentary canal. Infection may also start in the throat or, in some cases, in the upper respiratory tract and then spread downwards to the gastrointestinal tract.

The severity of the disease depends on the health and immune status of the patient and on the virulence of the virus. Fortunately, symptoms are negligible or even non-existent with the majority of infections, even for the most virulent strains of virus. Diagnosis can often be difficult as one virus may cause a variety of symptoms in different patients and different viruses may produce the same symptoms.

(ii) Occurrence and Stability of Viruses. Because they are excreted through the feces of an infected individual, human enteric viruses are the ones most often encountered at sewage treatment plants, and therefore, they are the ones most likely to be released to environmental waters. To a lesser extent, viruses may enter wastewaters from other sources such as blood and urine. Additionally, animals

TABLE B.1.b-1

## HUMAN ENTERIC VIRUSES THAT MAY BE PRESENT IN CONTAMINATED WATER

Virus Group (Size and Composition)	Number of Types	Disease or Symptoms Caused	Host Range for Natural Infection	Principal Cultivation Methods
ENTEROVIRUS (About 20-30 nm diameter. Single-stranded RNA in a protein shell)				
Poliovirus	3	Poliomyelitis, meningitis, fever	Man	Human and monkey cells
Coxsackievirus A	24	Herpangina, respiratory disease, meningitis, fever	Man	Newborn mice, human cells
Coxsackievirus B	6	Myocarditis, congenital heart anomalies, meningitis, respiratory disease, pleurodynia, rash, fever	Man	Newborn mice, human and monkey cells
Echovirus	34	Meningitis, respiratory disease, rash, diarrhea, fever	Man	Human and monkey cells
New enteroviruses	4	Meningitis, encephalitis, respiratory disease, acute haemorrhagic conjunctivitis, fever	Man	Human and monkey cells
HEPATITIS VIRUS type A (probably an enterovirus)	1	Infectious hepatitis	Man	No known method except possibly in marmosets and chimpanzees
GASTROENTERITIS VIRUS (possibly an enterovirus)	2	Vomiting and diarrhea	Man	No method available

TABLE B.1.b-1 -- Continued

Virus Group (Size and Composition)	Number of Types	Disease or Symptoms Caused	Host Range for Natural Infection	Principal Cultivation Methods
ROTAVIRUS (About 70 nm diameter. Double-stranded RNA in a single or double protein shell)	?	Vomiting and diarrhea, mainly with children	Human infants and calves	Limited replication in pig kidney, continuous monkey kidney, and human embryo kidney
REOVIRUS (About 75 nm in diameter. Double-stranded RNA in a double protein shell)	3	Not clearly established	Man	Human and monkey cells
ADENOVIRUS (About 70-80 nm in diameter. Double-stranded DNA molecule in a protein shell)	>30	Respiratory disease, eye infections	Man	Human cells
PARVOVIRUS (Small diameter. Single-stranded DNA molecule)				
Adeno-associated	4	Not clearly established but associated with respiratory disease in children	Man and some domestic animals	Human embryo kidney cells coinfecting with adenovirus

contribute viruses to water, but as yet viruses from this source do not appear to present a public health hazard.

Over 100 different enteric viruses are known to be shed in human feces [See Table B.1.b-1], and new ones are still being discovered. They are often excreted in very large numbers,  $> 10^6$  per gram of feces, and  $> 5 \times 10^5$  per liter have been found in sewage. Shellfish that are grown in waters contaminated with sewage effluent can bioaccumulate enteric viruses, including the virus of hepatitis A. Viruses may be harbored as long as two months or more in shellfish digestive tracts after all indications of water contamination have ceased.

The human enteric viruses, in general, are stable in an acid environment and in cold temperatures. They are resistant to bile, ether, and chloroform; but they are sensitive to heat, desiccation, and to various oxidants. All are relatively stable outside the host organism, and some can persist in water over long periods of time. As a result, human enteric viruses have been recovered from water long distances from the initial point of contamination.

(iii) Human Enteric Viruses Likely to be Recovered from Water. Viruses of concern to water authorities are those capable of causing major epidemics, as happened in New Delhi in 1955 - 1956 when the water supply became grossly contaminated with sewage, spreading infectious hepatitis to 28,000 people (Viswanathan, 1957). Yet, except for the hepatitis A virus, the public health significance of human enteric viruses in water remains unclear due possibly to the inapparent or latent nature of viral infections and the difficulty of detecting waterborne viruses.

(iii.1) Enteroviruses. These viruses comprise an acid-stable subgroup of the picornaviruses. Human enteroviruses include the polioviruses, the coxsackieviruses groups A and B, and the echoviruses [See Table B.1.b-1]. In addition, several new members (yet to be fully classified) recently have been discovered. Members of the picornavirus group contain single-stranded RNA and are further characterized by the absence of a lipid-containing envelope, average 28 nm size (most subgroups), and increased thermal stability in the presence of divalent cations.

The polioviruses are the most widely studied because they are easy to culture and they include vaccine strains that are safe to handle. Still, they are the most potentially dangerous of the enteroviruses, causing the major crippling disease of infectious origin.

Polioviruses are transmitted primarily through direct contact with pharyngeal secretions or feces of an infected individual. The seasonal peak incidence of poliomyelitis is in the summer and fall (as is true for most all of the enteroviruses) although sporadic cases do occur in any month of the year. In recent years, however, occurrence of poliomyelitis has been reduced significantly by the use of highly effective vaccines. Nevertheless, the virus has not been eliminated from the community, and vaccination programs must be maintained to prevent the resurgence of a susceptible group of children.

Infection with poliovirus and probably most of other enteroviruses normally confers lifelong immunity against the infecting virus strain (this is the basis of the live attenuated vaccine). The older a person is before becoming infected, the more severe his symptoms are likely to be. In many developing countries where sanitary conditions tend to be poor, waterborne spread of polioviruses and other enteroviruses almost certainly occurs. There, infection usually takes place early in life with severe symptoms being few and limited to young children. However, in developed countries where more hygienic conditions prevail, infection may be delayed leading to a greater proportion of serious disease in older age groups. This pattern, characteristic in developed countries, has been observed with poliovirus and can be expected with other viruses.

Eight outbreaks of poliomyelitis, which occurred during the period of 1900 - 1953, in Europe and North America, were attributed to transmission by water, however, Mosley (1967) believed that only one of them was adequately documented. In this instance, 45 cases of poliomyelitis occurred among families living in a cluster of temporary houses on the outskirts of Lincoln, Nebraska (U.S.) in June and July of 1952. The water supply was known to have wide fluctuations in pressure, and vacuum breakers were missing from a number of the toilets.

Where sanitation is good, the oral-oral spread of poliovirus may be more important than the fecal-oral route. For this reason and others mentioned earlier, water would

not appear to be involved with the transmission of polioviruses in developed countries.

The other enteroviruses are less well known, particularly the group A coxsackieviruses. They also can cause serious illnesses [See Table B.1.b-1] but, like the polioviruses, usually only in a small proportion of those infected (generally, poliovirus causes significant central nervous system disease in only 1 percent or less of those infected).

The most common of the diseases associated with enterovirus infections may well be aseptic meningitis: over 3,000 cases of this disease were reported in the U.S. during 1974. The disease can be paralytic, mimicking poliomyelitis; however, the cases are generally not as severe as those caused by the polioviruses (reviewed in Safe Drinking Water Committee, 1977). Many of the infections are so mild as to escape clinical recognition; others produce encephalitic manifestations and transient paresis. Aseptic meningitis also occurs most frequently in late summer and early autumn, but its incidence tends to be sporadic rather than epidemic. It is possible that the viral agents of meningitis might be transmitted via water, but there have been no documented instances of this as yet.

Although large numbers of enteroviruses have been isolated consistently from fecally contaminated water, only a few reports have implicated water as the vehicle of transmission. This may be due to lack of suitable detection methods and difficulty in demonstrating disease incidence epidemiologically. Or, it could be that the viruses recovered from sewage were the consequence of viral infection in a population rather than the source. The ambiguities surrounding the question of cause or effect with respect to virus occurrence in water will be elaborated on later in the discussion.

(iii.2) Hepatitis A Virus. Hepatitis A is the only form of viral hepatitis known to be transmitted through water and it is also the most prevalent waterborne disease attributable to a specific etiologic agent. Its spread, via sewage-polluted water, is well documented due to its clear-cut symptomatology and the explosive nature of its occurrence. It is therefore considered the most important viral disease transmitted through water.



The virus particle is apparently small enough to be either an enterovirus or a parvovirus and buoyant density studies suggest that it resembles an enterovirus. Its nucleic acid composition has not yet been determined. The agent seems to withstand acidity and heat, but perhaps not more than what the enteroviruses will endure. Though chimpanzees (and perhaps other primates) are infected accidentally on occasion, the only natural host of the virus seems to be man. Transmission is predominantly fecal-oral.

The incubation period of the disease in humans ranges generally from 15 to 50 days, with a median of 28 days. Some people shed the virus in their feces as early as seven days before onset of symptoms; others may transmit the virus without ever becoming perceptibly ill. Anorexia, nausea, and vomiting are seen in most cases; and jaundice is common but certainly not universal. Laboratory diagnosis is often based on demonstration of abnormally high levels of glutamic oxalacetic and glutamic pyruvic transaminases (SGOT, SGPT) in the patient's blood serum. The carrier state does not seem to be prolonged; the virus is usually absent from feces after the symptoms have abated and serum transaminase levels have become normal.

The hepatitis A virus has caused several serious epidemics and numerous small outbreaks in various parts of the world, some of which have been attributed to the consumption of polluted water or contaminated shellfish. Hepatitis A has been epidemiologically implicated in 66 waterborne outbreaks from 1946 to 1975, but its incidence in developed countries does not appear to be increasing. Moreover, the occurrence of hepatitis A as a whole (of which waterborne spread makes up only a small fraction), has shown a downward trend since 1971, in the U.S. Of the 22 waterborne outbreaks associated with municipal systems, three resulted from either inadequate or interrupted disinfection and five were related to the use of contaminated, untreated surface or groundwater. Half (eleven) of the outbreaks traced to municipal systems occurred as the result of contamination of the distribution system, primarily through cross-connections and back-siphonage (Craun, 1978) [See Section F.4].

Attempts to culture the hepatitis A virus in cell lines have consistently failed so that all available evidence about its transmission by polluted drinking water has been obtained from epidemiological surveys. Human volunteers and chimpanzees have, however, been infected with the virus, and

recently developed methods employing immune electron microscopy (IEM) have afforded some progress. These investigations indicate that the hepatitis A virus may soon be classified as an enterovirus. If so classified, the hepatitis A virus could be expected to react to water treatment and purification processes in a manner similar to the other enteroviruses [See Section E.].

(iii.3) Gastroenteritis Viruses. Another group of small viruses potentially transmissible through water, some of which may in fact be enteroviruses, are called gastroenteritis viruses. Included in this heterogeneous group are the Norwalk agent and the related Montgomery County and Hawaii agents, rotaviruses, astroviruses, coronaviruses, caliciviruses, the W agent, the cockle virus, and the Ditchling agent [See Section B.1.d]. These have all been detected in diarrheal feces by direct electron microscopy. They do not replicate in routine cell cultures, although some have been shown to replicate to some extent in particular cells (reviewed by Madeley, 1979).

Gastroenteritis is probably the most common waterborne disease in developed countries and was reported to have involved 45,255 cases in 178 outbreaks between 1946 and 1970 within the U.S. (Craun and McCabe, 1973). Gastroenteritis epidemics of viral origin are known to be spread by personal contact; and it seems reasonable to suspect that many waterborne gastroenteritis outbreaks might stem from the same etiologic agents. [See Section B.1.d.]

(iii.4) Rotaviruses. These viruses are related to the reoviruses and belong to the same family, Reoviridae. They have been shown to be antigenically related to viruses of similar morphology isolated from various animal species; but they are antigenically distinct from reoviruses and orbiviruses. Rotaviruses are primarily associated with gastroenteritis in children.

Characterizations of rotaviruses have been made possible by the use of electron microscopy, and recent investigations suggest the possibility of more than one human serotype (reviewed by Madeley, 1979). The viruses have been concentrated and purified from fecal extracts for biochemical and biophysical characterization. Rotaviruses are described as being 70 nm in diameter and appear to contain double-stranded RNA and a protein component with eight

distinct polypeptides observed by electrophoresis. Particles with single- and double-shelled capsids have been detected at bouyant densities of 1.36, and 1.37 g/ml in cesium chloride gradients (Rodger, et al., 1975).

The route(s) of transmission of rotaviruses associated with diarrheal disease in infants and children has not been identified, although direct person-to-person spread has been indicated in some hospital nurseries. In temperate climates, infections with rotaviruses increase during the cold winter months; and at peak times, rotaviruses have been observed in fecal specimens of as many as 90 percent of young hospital patients. A few studies have indicated that adults may also be infected with rotaviruses, usually resulting in relatively mild gastroenteritis. The isolation of rotaviruses from U.S. students who experienced "travelers' diarrhea" while attending a Mexican university and from a community-wide outbreak in Sweden suggests that water transmission of the agent should be considered (Bolivar, et al., 1978; Lycke, et al., 1978). Rotaviruses may be excreted in very large numbers (up to  $10^9$  per gram of feces -- Madeley, 1979) and they are almost certain to be present in polluted water, but there is presently no suitable method for their detection at low concentrations [See also Section B.1.d].

(iii.5) Reoviruses. Reoviruses are members of the Reoviridae and share a number of properties with the enteroviruses (e.g., spherical shape, lack of an envelope) -- only reoviruses are larger and possess double-stranded RNA cores [See Table B.1.b-1]. They are unusual in that they infect a wide range of animals; furthermore, they have been recovered from persons with a wide variety of illnesses including upper and lower respiratory tract disease, gastrointestinal disease, steatorrhea, exanthems, and some central nervous system diseases. Although they have been found to be highly infectious and have been isolated frequently from sewage and contaminated water, their etiologic role in man has not been established (Horsfall and Tamm, 1965).

(iii.6) Adenoviruses. Adenoviruses are icosahedral and contain double-stranded DNA [See Table B.1.b-1]. At least 28 types are recognized and many serotypes have been isolated from human sources. The adenoviruses resemble enteroviruses only in their resistance to ether and absence of a lipid-containing envelope.

Members of this group generally are considered to be respiratory viruses; they can infect the upper respiratory tract as well as the intestines, typically without evidence of disease. Adenoviruses are often shed for prolonged periods in the feces of young children. They have been isolated frequently from stool specimens, sewage, and contaminated water. Curiously, only a few of those seen in feces by electron microscopy have yielded to culturing in cell lines.

The adenoviruses produce sporadic infections in the general population which tend to be highest in the colder months; but, overt disease is rare. Although they occasionally appear to have been involved with outbreaks of diarrhea, reports of their transmission through water have been connected only with outbreaks of conjunctivitis in persons frequenting swimming pools. Adenoviruses are readily inactivated by free chlorine at levels commonly used to protect water supplies; hence, they should be entirely absent from adequately disinfected drinking water.

(iii.7) Adeno-Associated Viruses. The adeno-associated viruses are members of the parvovirus group and, as such, are the smallest of animal viruses, some having diameters of as little as 19 nm. They are polyhedral, lack a lipid-containing envelope, and contain one molecule of single-stranded DNA. Buoyant density studies have placed them between 1.38 and 1.46 g/ml in cesium chloride. They comprise four known serotypes which have been found to chiefly infect the lower animals such as rats, mice, cats, dogs, swine, and birds; however, infectivity appears dependent on concurrent infection with adeno- or (less readily) herpesviruses. By themselves, the adeno-associated viruses are not known to cause any symptoms. They have, however, been recovered in association with childhood respiratory diseases.

These viruses are quite stable outside of the host organism and can withstand heat at 60°C for at least 1 h. They are highly resistant to many physical and chemical agents and are unaffected by ether, chloroform, and anionic detergents.

Since they have been isolated from feces together with adenoviruses, they are almost certain to be present in fecally contaminated water, although no method for their detection in water is currently available for confirmation.

There are, at present, insufficient data on these viruses for determining their pathogenicity and hence, for judging what, if any, threat they might pose if ingested with drinking water.

(iv) Methods for Detecting Viruses in Water. As more and more water is used to receive waste discharges and run-off from domestic, agricultural, industrial, and recreational uses, the opportunities for fecal, and therefore viral, contamination will increase accordingly. Most enteric viruses are shed in large numbers in the feces of infected persons, although it should be noted that the majority of people in industrialized nations are not infected with enteric viruses on any given day. Because viruses multiply only within susceptible host cells, they cannot increase in sewage. Their numbers are further reduced as a result of sewage treatment, dilution, natural inactivation, and water treatment practices [See Section E.]. Therefore, barring gross contamination of finished water, only low numbers of virus, if any, are likely to occur in properly treated supplies.

(iv.1) Concentration Techniques. The possible presence of only very low numbers of virus necessitates applying highly efficient methods, including a preliminary concentration step, to demonstrate and quantitate any viruses present. Some source waters may contain viruses at such low levels that sample volumes of 400 l or more would be required to enable them to be detected.

Adsorption methods employing glass microfibers (Jakubowski, 1974) and glass powder (Sarrette, *et al.*, 1977) appear promising for handling large volumes of water containing few viruses. Concentration with glass microfibers permits sampling of 2,000 l or more of water and is recommended as a tentative procedure in Standard Methods (American Public Health Assoc., 1975). Many of the enteroviruses can be adsorbed at pH 3.5 to 4.5 in the presence of  $AlCl_3$ , followed by elution with a protein solution at pH 9.5 or 0.05 M glycine buffer at pH 11.5. Excellent reviews of these methods have been published (Foliquet, *et al.*, 1973; and Sobsey, 1976).

Raw water containing suspended matter and organic substances may require more conservative analytical procedures, such as the aqueous polymer two-phase separation

technique described in Standard Methods (American Public Health Assoc., 1975). If enteric viruses are entrapped in fecal clumps, special procedures must be employed to disrupt the clumps, releasing the virus.

(iv.2) Cell Culture Techniques. Human enteric viruses, if they will replicate at all in the laboratory, must do so in primate cells, although no one cell culture will accommodate all of the various enteric viruses capable of propagation in cell lines. Therefore, selection of host cell systems will, of necessity, be a compromise between what one expects to find, what one knows will yield to culturing, and what costs one can afford.

Enteroviruses, reoviruses, and some adenoviruses can be detected by conventional cell culture techniques using human primary amnion or fetal cells (such as embryonic kidney) and suckling mice. For the coxsackieviruses A, all but three of the 24 types are isolated only in suckling mice. Human diploid embryonic lung cells were used successfully to recover 31 echoviruses (reviewed in Safe Drinking Water Committee, 1977). Unfortunately, there are yet many known enteroviruses that have no known tissue culture hosts. Likewise, there is no laboratory host system for detection of the virus of hepatitis A.

Neither are there cell culture systems for detecting gastroenteritis viruses, although rotaviruses will replicate, to a limited extent, in pig kidney, continuous monkey kidney, and in human embryo kidney (reviewed by Madeley, 1979). The Norwalk, Montgomery, and Hawaii agents, along with rotaviruses, adenoviruses, caliciviruses, the W agent, cockle virus, and the Ditchling agent are detectable, when present in patients' stools at high enough levels (at least  $10^{-6}$  pfu per g feces), using electron microscopy.

Adenoviruses can be cultured only in human cells, and adeno-associated viruses are cultured on human embryo kidney cells concurrently infected with adenoviruses. Quantitation of adeno-associated viruses is thereby handicapped by the necessary inclusion of a helper virus to induce infectivity.

(iv.3) Virus Identification Techniques. Serologic methods for virus identification can be based on serum

neutralization or antigen-antibody interactions. The antigen-antibody tests (comprising immunofluorescence and immunoenzymatic procedures) yield results sooner than the visible cytopathic effects required for interpretation of serum neutralization tests. However, these immunochemical techniques have not been adapted to use pooled antisera and so, unlike serum neutralization tests, they require as many individual reactions as there are virus types to be identified.

(v) Public Health Significance of Viruses in Drinking Water. The presence of viruses, pathogenic to humans, in groundwater, streams, rivers, and lakes, is certain. The majority of these emanate from domestic sewage but are present in widely fluctuating numbers, anywhere from no viruses per 100 ml to over 45,000 viruses per 100 ml of sewage (Gerba, et al., 1975a). The season, hygienic level of the population, and incidence of disease in a particular community are the major determinants of viral presence, and these factors all are subject to change.

Except for the occurrence of waterborne hepatitis A, however, there is little evidence to connect the presence of enteric viruses in water with incidence of viral disease. Although isolated regularly from sewage and environmental waters, the picornaviruses have not been demonstrated, epidemiologically, to cause disease by this route. Conversely, those outbreaks of gastroenteritis that have been traced to water have not been shown to be of viral origin.

If the epidemiologic data on transmission of hepatitis A through water are representative, it may be useful to consider the kinds of circumstances which have led to water-associated outbreaks of this disease. The overwhelming majority of reported waterborne outbreaks of hepatitis A were attributable to untreated or inadequately treated water supplies. In the case of semipublic and private water supplies, the fault lay usually with sewage contamination of the source coupled with little or no treatment. With large municipal supplies, the problem usually was one of cross-connections or back-siphonage during distribution. The solutions to these obvious deficiencies are straight-forward and attainable.

On the other hand, it is believed by some that viral infections may be spread insidiously by way of continual low level transmission through water. It is the nature of most

viral diseases that they elude the epidemiologist in his quest for definitive data. Many viruses can cause inapparent or latent infections which go unrecognized until secondary person-to-person spread finally leads to overt disease in scattered, virtually untraceable pockets of the population. One case in point is the picornaviruses, the majority of which cause subclinical infection much more frequently than overt disease.

Inadequacies in current water treatment techniques have been demonstrated on several occasions when viruses were isolated from conventionally treated potable supplies which had received treatment adequate to remove bacterial pathogens (Berg, et al., 1975; Jenkins and Mendia, 1967; Hoehn, et al., 1977). Whether the extremely small numbers of viruses that manage to get through into drinking water are sufficient to initiate infection in a community, or whether other modes of transmission play a much more prominent role in disseminating them, is not yet known.

Virus interactions with tissue cultures and with the intact host do not appear to be entirely comparable, although such comparisons have been made. There is evidence to suggest that anywhere from a few to a great number of viral particles must be present to account for one tissue culture dose (TCD) -- that quantity of virus required to produce in a tissue culture an infection that is perceptible on the basis of cytopathic effect, plaque formation, or some other manifestation. The number of virus particles corresponding to a TCD sometimes ranges in the thousands but is always greater than one. Although tissue cultures vary in their susceptibility to any given virus, it is clear that the process by which animal viruses initiate infection is inherently inefficient; there is no known system in which every single animal virus particle succeeds in initiating infection. The number of viral particles that equals a TCD varies with the cell line as well as with the virus; the laboratory procedures used to make these determinations impose further uncertainties. Finally, host cells in culture may not be strictly representative of intestinal cells *in vivo*; hence, experiments which try to relate TCD's manifested in cell lines to human infectious doses have produced quite disparate results.

Infection and disease are not synonymous. Viral infections may be highly prevalent when the incidence of viral disease is low. The occurrence of disease among infected persons is strongly dependent upon the individual hosts'



susceptibilities. A detailed summary of this topic is presented by the Safe Drinking Water Committee (1977).

For all of the reasons outlined above, reported levels of viral contamination in water cannot be used directly to assess the risk to human health. If surveillance programs were equipped and staffed to detect virus infections, there would be an increased likelihood of tracing sources of viral disease. However, such an approach would be almost impossible to implement because of the considerable expense and personnel time it would consume. Studies to determine virus levels in drinking water, in conjunction with epidemiologic surveys of viral disease in the community, are sorely needed. Epidemiologists and public health laboratories must have available to them the expertise for conducting extensive virologic studies whenever disease is suspected of being waterborne and the etiologic agent is unknown. Until information gathered from such investigations is forthcoming, the public health significance of small numbers of viruses in drinking water will remain undetermined.

(i) Entamoeba histolytica. This protozoon causes amebic dysentery as well as such other clinical manifestations as diarrhea, abscesses of the liver (or less commonly of the lung or brain), and skin ulceration. It can also cause chronic infections with minimal symptoms, or the organism may act as a commensal within its asymptomatic host carrier. Amebiasis (infection with E. histolytica) occurs world-wide; and dysentery epidemics are, by and large, waterborne -- usually the result of poor sanitation.

(i.1) Characterization and Pathogenesis. Entamoebidae is the only exclusively parasitic family in the order Amoebida; and E. histolytica (referred to in some American literature as Endamoeba) is the only true pathogen among five species of amebae which parasitize the human intestine. Two other members of the genus Entamoeba, E. coli and E. hartmanni, are harmless intestinal parasites, the latter morphologically resembling E. histolytica and easily confused in clinical diagnoses.

E. histolytica exists in both the actively growing trophozoite (9 x 11 um or 18 x 25 um) and dormant, thick-walled cyst (6 to 8 um or 12 to 15 um in diameter) states, as do the other intestinal amebae (except Dientamoeba fragilis which exists only as a trophozoite). The organism

is not infectious when passed in the feces of patients with acute dysentery, owing to its occurrence at this time as a fragile trophozoite. However, once lodged in the host, trophozoites can attack the walls of the intestine, feeding characteristically (but not exclusively) upon red blood cells. They may penetrate the intestinal lining, causing intense inflammation and ulcers (amebic dysentery). They may also gain entry to the lymph and blood vessels and then be carried to the liver, lungs, brain, and other organs where abscesses will result. Cysts are passed in the feces of asymptomatic carriers or of patients with chronic or mild cases of amebiasis; in this way, they may spread the disease.

As early as the 1940's, most researchers agreed that other factors beyond the solitary presence of E. histolytica were needed to provoke an infection (Chang, 1948). When axenic E. histolytica cultures were administered to gnotobiotic guinea pigs, no symptoms were apparent. However, animals whose intestines harbored either E. coli or A. aerogenes developed ulcerations after receiving the pathogen (Phillips, et al., 1955). The importance (but not the exact role) of an accompanying bacterial flora was realized: one proposed mode of mixed etiology was supposed to involve a profound anaerobiosis occurring as a result of disturbance to the normal bacterial flora (Chang, 1948). Such anaerobiosis would ostensibly favor penetration of the mucosa by E. histolytica. In its vegetative stage (trophozoites), E. histolytica is extremely fragile and is killed in 35 min at 45°C, in 2 to 5 h at 32°C, in 6 to 12 h at 25°C, and in 18 to 96 h at 15°C. The cysts are more resistant, being able to survive in the environment for three to four days at 25°C and more than four weeks in slightly alkaline water.

Although the U.S. Center for Disease Control has, in the last decade, received from 2,000 to 3,000 annual reports of symptomatic amebiasis (Center for Disease Control, 1977c), none since 1953 has been waterborne. Those which did occur prior to 1953 involved sewage contamination of water supplies that primarily serviced private distribution systems. It is clear that cross-connections or back-flow of sewage into water supply lines must be prevented in order to preclude transmission of E. histolytica through drinking water [See Section F.4]. No waterborne outbreak of symptomatic amebiasis has been reported in Western Europe during the 1970's.

(i.2) Effects of Treatment Practices. In the U.S., improved sanitary sewerage systems have been largely responsible for the curtailment of waterborne amebic dysentery. Also important has been the introduction of coagulation [See Section E.2] and filtration during water treatment. Sand filtration of water [See Section E.3] removes nearly all cysts, and diatomaceous earth filters remove them all. Data on survival of E. histolytica exposed to iodine [See Section E.5.d] are summarized in Figures B.1.c-1 and 2. The parameter of cysticidal residual used in these calculations is defined as that concentration required to kill 99.999 percent of cysts. High pH decreases the cysticidal activity of chlorine [See Section E.5.a], bromine, and iodine. But at pH 4, a bromine residual of 1.5 ppm produced 99.9 percent cyst mortality, whereas 5 ppm iodine residual and 2 ppm chlorine residual were required for the same results under the same conditions. Ozone, applied at 0.5 ppm, can kill 97 to > 99 percent E. histolytica cysts suspended in tapwater (Newton and Jones, 1949) [See Section E.5.b]. Also, heating to 52°C for 2 min destroys E. histolytica cysts (Chang, 1950); and drying causes instantaneous death (Chang, 1948). Finally, water storage for four weeks at 10°C and for one week at 20°C destroys cysts.

There is at present no standardized method for detecting E. histolytica in water. Various methods for concentrating by filtration have been recommended. Detection is essentially accomplished by careful microscopic examination of concentrated or unfiltered water samples that have or have not been stained. However, laboratory diagnosis for E. histolytica is often difficult and requires highly specialized procedures.

(ii) Giardia Lamblia. This protozoon infects the small bowel and causes prolonged diarrhea and several other intestinal symptoms. It is the most frequently diagnosed parasitic pathogen in U.S. public health laboratories; moreover, giardiasis appears to be emerging as a major waterborne disease, having been responsible for 14 waterborne outbreaks in the U.S. between 1965 and 1975, 12 of which occurred between 1971 and 1974 (Horwitz, et al., 1976). It was not until 1966 that water was recognized as a vehicle of giardiasis transmission, and since that time, increased awareness on the part of physicians may have accounted for the more frequent reporting of outbreaks.

FIGURE B.1.c-1

RELATIONSHIP BETWEEN CYSTICIDAL RESIDUAL<sup>a</sup>,  
TITRATABLE IODINE, ( $I_2$ ), AND CONTACT TIME<sup>b</sup>  
AT 3°, 10°, 23°, AND 35°C<sup>b</sup>

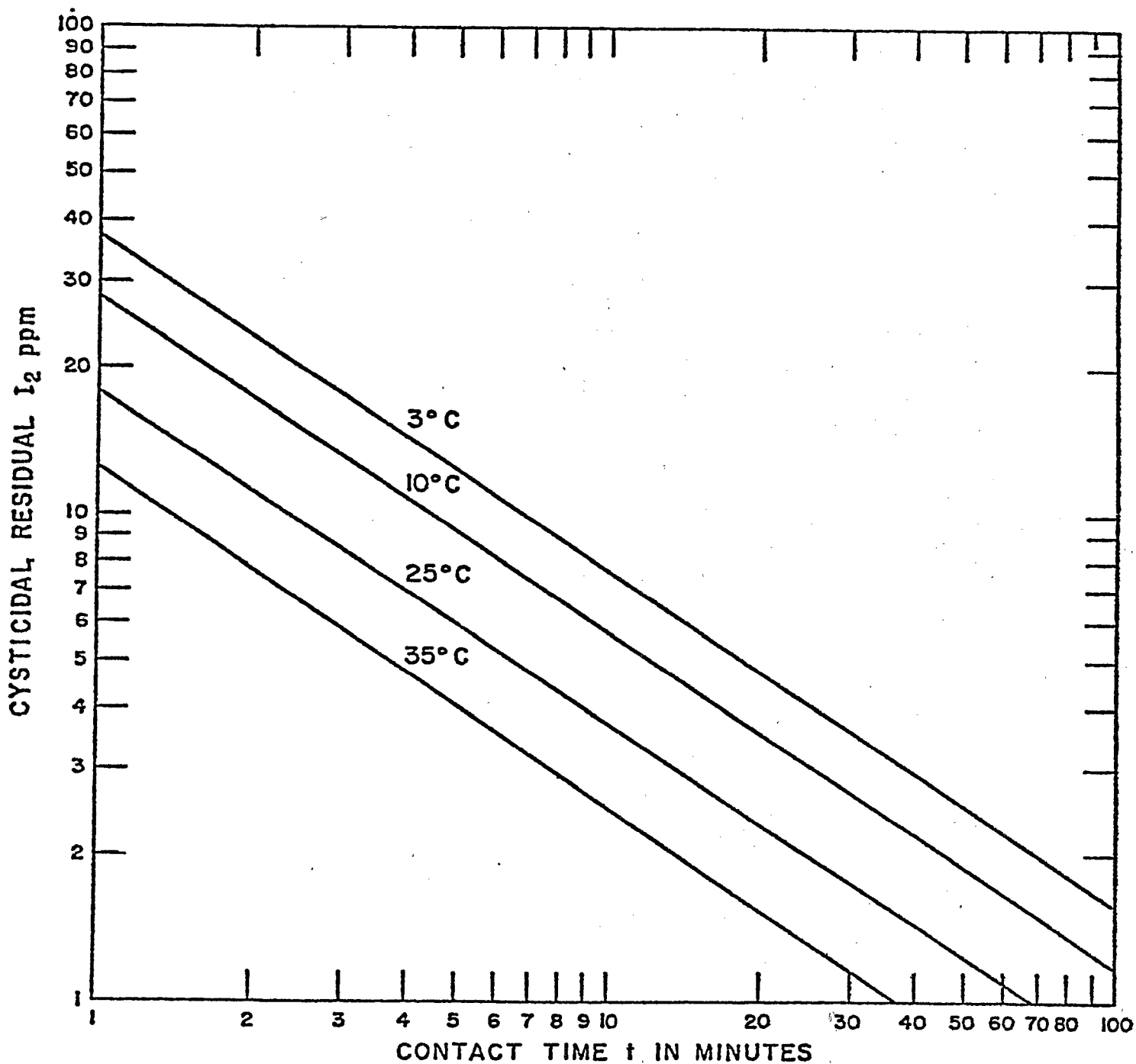

<sup>a</sup>Concentration needed to kill 99.999% of cysts.

<sup>b</sup>pH < 6.5 and iodine ion concentration < 20 ppm.

FIGURE B.1.c-2

RELATIONSHIP OF CONTACT TIME TO CONCENTRATION OF  $I_2$  AND HOI FOR DESTRUCTION OF 99.9% OF CYSTS, VIRUSES, AND BACTERIA AT 18°C

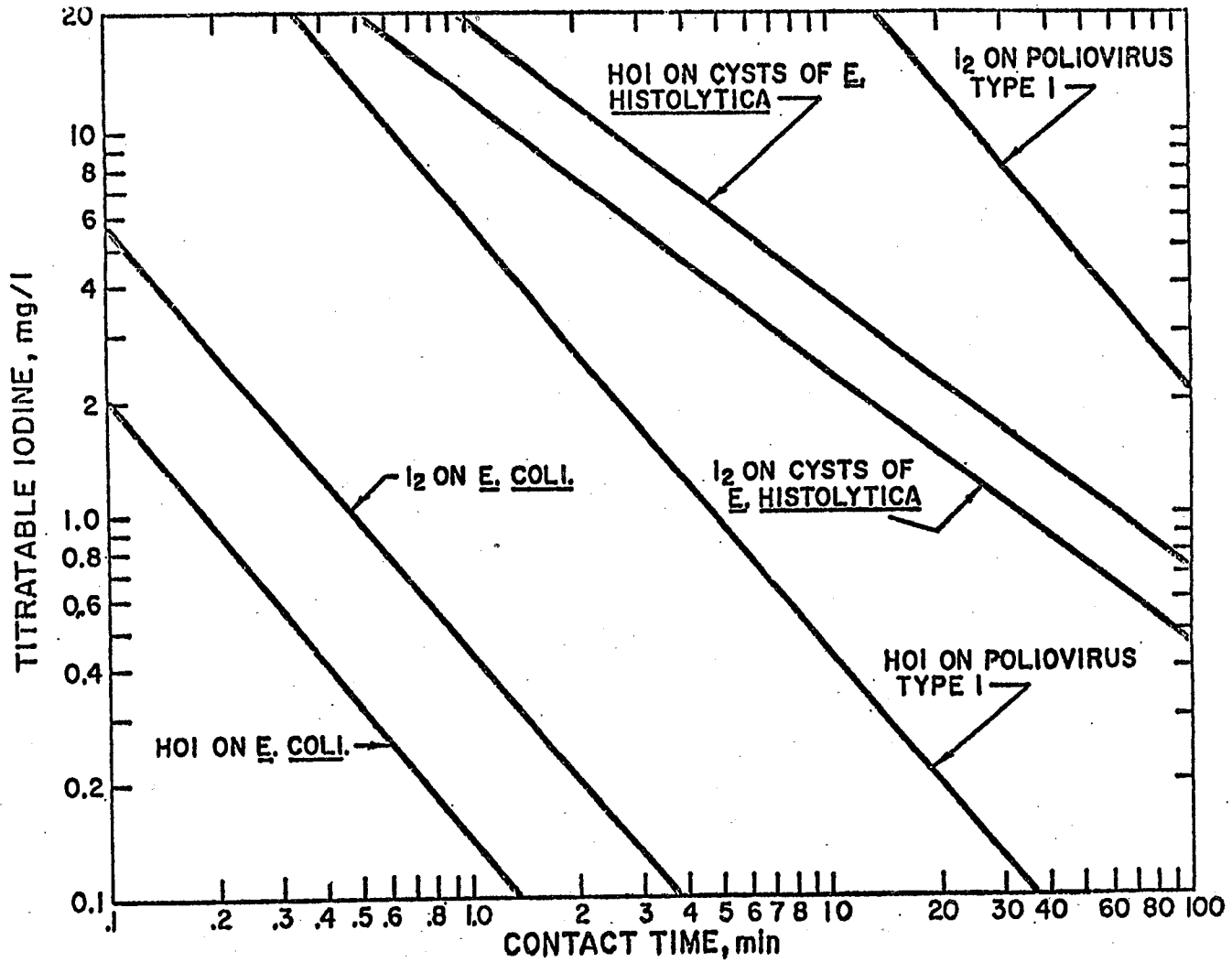

(ii.1) Characterization and Pathogenesis. The flagellate G. lamblia exists as both trophozoite (9 to 18  $\mu\text{m}$  x 6 to 9  $\mu\text{m}$ ) and cyst (9 to 12  $\mu\text{m}$  x 5 to 8  $\mu\text{m}$ ). After being ingested as cysts, the organisms quickly develop into infectious trophozoites, coating the mucosa of the duodenum and upper jejunum and often causing such changes as flattening of villi and roughing of mucosal surfaces; the flagellate bodies may imbed deeply in the villi (Burke, 1975; Nath, et al., 1974). The large number of trophozoites lining the mucosa interferes mechanically with absorption (especially of fats) and enzyme activity, and this can lead to weight loss, malnutrition, and anemia. Symptoms, which include chronic diarrhea, steatorrhea, and abdominal cramps, are generally more severe in children (especially those with any immunodeficiency) than in adults.

(ii.2) Epidemiology. Beavers were implicated as the source of a waterborne giardiasis outbreak which took place in Camas, Washington (U.S.) in 1976, which included 128 confirmed cases in a population of 6,000 people (Dykes, et al., 1977). Beavers, but not coyote, opossums, nutrias, or porcupines, were found to be carrying G. lamblia cysts which were recovered from both raw and finished surface waters. The beavers inhabited a pond bordering a heavily used state park and were within foraging distance of water intakes for Camas [See also Section B.2]. A similar epidemic occurred a year later in Berlin, New Hampshire (U.S.) where at least 205 residents (an attack rate of  $\sim$ 25 percent) were confirmed to be ill with giardiasis. Sewage contamination of one raw water source was demonstrated, and unrestricted public access to the other source provided opportunity for fecal contamination (Center for Disease Control, 1977c). Beavers trapped nearby were found with intestinal lesions produced by Giardia trophozoites.

The first laboratory confirmed (using pathogen-free beagle dogs) outbreak of giardiasis in the U.S., also the largest outbreak to date, involved an estimated 5,300 persons (in a population of 46,000) in Rome, New York; 359 of the cases were clinically confirmed (Shaw, et al., 1977). Raw mountain stream water from the heavily wooded, sparsely populated watershed had routinely shown low coliform counts over a two-year period, but very high total bacterial counts were recovered from water in the distribution system. This led investigators to conclude that raw water, though not contaminated with human sewage, was insufficiently chlorinated during treatment. However, they went on to caution against reliance on chlorine for destroying Giardia cysts.

Every U.S. outbreak involving municipal water supplies, except one, has been associated with surface water sources where disinfection was the only treatment. The one exception occurred in Aspen, Colorado in 1965 and 1966 (Moore, et al., 1969). Wells provided the town's water, but old, broken and leaking sewer lines passing close by served as the source of contamination.

(ii.3) Effects of Treatment Practices. G. lamblia cysts are not destroyed by chlorination at dosages and contact times commonly used in water treatment [See Section E.5.a], nor do closed pressurized filtration systems afford adequate protection, as was evidenced in the Camas outbreak. Beyond ensuring against opportunities for fecal contamination, water treatment regimes should include coagulation [See Section E.1], sedimentation [See Section E.2], and filtration [See Section E.3]. When aluminum sulfate was applied to water maintained at usual pH levels and turbidities encountered at a water treatment facility, 99.999 percent of suspended Giardia cysts were removed. The addition of calcium and/or magnesium salts to aid floc formation is recommended for very cold or very soft waters. Filters should be of adequate depth and the rates of filtration and back-flushing should be adjusted to ensure entrapment of cysts and to prevent turnover or channeling of the filter.

Proper maintenance is essential. The greatest risks will occur in water systems that use only disinfection and in contamination of water in the distribution system by sewage from broken lines or from cross-connections. More study is needed to define the conditions required for destruction of G. lamblia cysts.

Concentration techniques, using microporous filters, for recovery of G. lamblia cysts are based on established methods for concentrating viruses. When culture methods become available for inducing G. lamblia to excyst, propagate, form trophozoites, and encyst in one complete life cycle, the organism will then be accessible for closer scrutiny and possible eradication as a waterborne agent of disease.

(iii) Naegleria Fowleri. The facultatively parasitic ameba, Naegleria fowleri, has, in the recent past, been recognized as one of two agents (also Acanthamoeba) responsible for causing primary amebic meningoencephalitis (PAM), mostly in children and young adults -- a disease which is usually

fatal within three to seven days. The organism is a free-living ameba, ordinarily found in water, soil, and decaying vegetation. There is no evidence of any person-to-person transmission; instead, the infection appears to take hold, in most instances, when water containing N. fowleri cysts enters through the nose, usually as a result of swimming in fresh water lakes, swimming pools, or hot springs. Though associated with recreational waters, the ameba has more recently been isolated from tapwater in connection with incidences of PAM (Safe Drinking Water Committee, 1977).

(iii.1) Characterization and Pathogenesis. The first two known cases of PAM occurred in 1962, in Orlando, Florida (U.S.), but the causative agent was not definitely identified until several years later when a Naegleria species was isolated from cerebrospinal fluids grown on inorganic agar seeded with coliform bacteria (Butt, 1966; Butt, et al., 1968).

The genus Naegleria belongs to the family Schizopyrenidae, of which N. fowleri (which has been successively named N. fowleri, N. aerobia, and N. invades by different investigators) is the only species known to be pathogenic. The ameba measures approximately 8 - 15  $\mu$ m and has a spherical nucleus and one or more lobate pseudopodia. It exists either as a cyst or a trophozoite; the latter becomes flagellated after a few hours in water. Trophozoites are indistinguishable from those of the nonpathogenic N. gruberi in freshly prepared specimens. Both species have a conspicuous centrally located nucleolus and are slightly smaller than E. histolytica; they must be differentiated by serological tests.

Pathological findings indicate that, once insinuated into the nasopharynx, the ameba can "chew" its way from the roof of the nose through the cribiform plate into the cranial cavity. A phospholipase-like enzyme of the ameba can decompose syringomyelin in a chemically defined medium; this enzyme is probably the means by which the ameba can penetrate the olfactory mucosa and find its way into the brain through the olfactory nerve plexus (Chang, 1978). Extensive demyelination of the white matter in the central nervous system has also been attributed to the action of this enzyme. The typical syndrome comprises fulminating meningoencephalitis with severe frontal headache, nausea, vomiting, high fever, nuchal rigidity, and somnolence, with death on the fifth or sixth day.



(iii.2) Sources and Occurrence. Cases of PAM have been reported in Australia, Czechoslovakia, the U.K., Ireland, Belgium, New Zealand, India, Africa, and the U.S. As of 1974, there were 64 cases reported worldwide, most have occurred during the hottest time of the year. In South Australia, infection is believed to have occurred as the result of school children washing their noses with ameba-laden tap water (Fowler and Carter, 1965). In Czechoslovakia, a swimming pool (and possibly a stream) was the source of infection (Cerva and Novick, 1968); a swimming pool and thermally polluted stream served as vehicles of infection in Belgium. All cases in the southeast U.S., except one, were traced to swimming in lakes; in California, two victims had a history of swimming in a creek fed by a hot spring. An extensive survey of lakes in the Orlando, Florida (U.S.) area (Wellings, et al., 1977) revealed the presence of N. fowleri in 12 out of 26 lakes examined (single sample). Moreover, viable cysts, identified as Naegleria and Acanthamoeba species, have been found in eight of 15 finished water samples in a survey of large city supplies across the U.S. (reviewed in Safe Drinking Water Committee, 1977).

Increasing eutrophication and thermal pollution of water are likely to enhance the growth of N. fowleri. However, evidence of its rather widespread presence has not been associated with widespread occurrence of PAM. In fact, there has been no case in Czechoslovakia since 1968, in Australia since 1972, in Belgium since 1973, and in New Zealand since 1975. Other unknown factors may be important accompaniments to the occurrence of infection and should be investigated in view of the disease's high fatality.

(iii.3) Persistence. Little is known about the stability of N. fowleri cysts and trophozoites. Cysts very likely are resistant to chlorine [See Section E.5.a] as are those of other parasitic amebae; therefore, emphasis should be placed on coagulation [See Section E.2] and filtration [See Section E.3] processes to remove these organisms from waters in which they may be proliferating.

(iv) Acanthamoeba Species. Acanthamoeba, also associated with PAM, is the most widely distributed, free-living ameba in all types of fresh water and in sewage effluents (Chang, 1971a).

This facultative parasite measures 10 - 25 um and has multiple, spine-like filiform pseudopodia. Cysts have a double layered wall and, upon aging, give a wrinkled appearance from retraction of the inner wall. Acanthamoeba is able to grow axenically on ordinary media such as tryptic digest soy broth or even peptone solution; in contrast, Naegleria generally requires the presence of living bacteria, tissue culture cells, fresh tissue, or fetal calf serum.

Species of Acanthamoeba were formerly classified within the genus Hartmannella (Singh, 1953). There are still problems in the differentiation of individual species due to morphological and cultural similarities and because single strains oftentimes exhibit morphological variability, even under the same growth conditions (Chang, 1971a). Species must therefore be classified on the basis of serology. Acanthamoeba cysts are extremely resistant to chlorine [See Section E.5.a], drying, and freezing.

Experimental evidence indicates that all Acanthamoeba species, except A. palestinensis, are at least mildly pathogenic. Infection does not occur through any specific portal of entry; rather, the organism is believed to be a secondary invader taking advantage of abrasions, ulcers, or other infections initiated by other organisms (Chang, 1971a). When an ulcer is well established, the amebae may consume all the bacteria and feed on the exudate and cell debris. Acanthamoeba has been implicated in PAM cases of patients who were debilitated or undergoing immunosuppressive therapy.

Like Naegleria fowleri, Acanthamoeba species have been isolated from tapwater in association with PAM cases (reviewed in Safe Drinking Water Committee, 1977). However, their presence in finished drinking water seems unlikely to lead to PAM in the consumer. Acanthamoeba is detected by microscopic examination of the water sample.

(v) Helminths (Worms). In the U.S., metazoan parasites that may be transmitted by ingestion of water are limited to a few intestinal nematodes (roundworms) and even fewer trematodes and cestodes (flatworms). Of the nematodes, the following merit consideration: Ascaris lumbricoides (the stomach worm), Trichuris trichura (the whipworm), Necator americanus, Ancylostoma duodenale, A. brasiliense (hookworms), and Strongyloides stercoralis (the threadworm). Cestodes of

public health significance are Hymenolepis nana (the dwarf tapeworm) and Echinococcus granulosus (the dog tapeworm).

Eggs of the intestinal nematodes originate from feces and may be shed directly into surface waters or indirectly through surface water run-off or drainage from polluted soil where conditions would favor development of infective larvae. In order to infect, a hookworm larva normally must penetrate the host's skin, most commonly as a result of walking bare-foot on polluted soil. However, infection can also be acquired through penetration of oral mucosa by waterborne larvae which, in the case of Strongyloid larvae, have been found in drinking water as well as on leafy vegetables (Strong, 1944). The guinea worm Dracunculus medinensis is a nematode that develops as an infective larva in copepods, usually Cyclops. Humans can become infected by drinking water containing the larvae, and eggs may subsequently exit through the feet as a result of wading. D. medinensis is not endemic in the U.S.

Due to the complex life cycle of trematodes, infection occurs and is endemic only in areas where the appropriate intermediate snail host is present. Most cestodes that parasitize humans require vertebrates (cattle, swine, fish) as intermediate hosts. Cestode life cycles are relatively simple and the organisms are more widely disseminated in nature, particularly Hymenolepis nana and H. diminuta. H. nana is a tapeworm of man, but can incidentally infect rats and mice; H. diminuta is a tapeworm of rats and mice, but occasionally is found in humans. Water contaminated with human feces or rat droppings may serve as the vehicle of transmission, and the fully embryonated eggs are infective upon ingestion.

Eggs of most parasitic helminths are large, about 50  $\mu$ m in diameter or larger, and being heavier than water they are easily removed by standard water treatment processes that include storage, coagulation, sedimentation, and filtration [See Sections E.1 through 3]. However, the infective larvae of hookworms and threadworms are highly motile and can sometimes move through sand filters. Consequently, sand filtration and flocculation have not proved to be adequate safeguards against these larval forms. They are also much more resistant to disinfectants than are enteric bacteria, viruses, or even protozoan cysts. If such larvae are suspected in drinking water, heating to boiling is the only safe measure. On the other hand, the chances of obtaining a

serious worm infection via drinking water are extremely slim considering that: (1) eggs and most larvae settle out in water; and (2) each egg or larva develops into only one worm in the host, and this inability to replicate, coupled with the enormous dilution effect in water, makes transmission through drinking water highly unlikely. Such conditions of relative safety do not, however, apply to wells polluted with surface water nor to systems that use chemical disinfection as the sole treatment.

Since hookworm and threadworm larvae are about the same size as the harmless free-living adult nematodes (0.75 to 1.0 mm long, 40 to 60  $\mu$ m wide) and since these latter are frequently found in water supplies and breed well in slow sand filters, there are opportunities for mistaken identity. The harmless, free-living nematodes include members of the genera Cheilobus, Diplogaster, Diplogasteroides, Trilobus, Aphelenchus, and Rhabditis. They normally inhabit the soil, and if present in wastewater influent, will flourish during aerobic sewage treatment such as by trickling filters or activated sludge. Effluents from such treatment plants, upon entering receiving waters, may contain large numbers of these organisms. Sand filters used to process raw water for drinking purposes may become infested with these organisms, which ultimately will be carried through the distribution system to the consumer. Nevertheless, it should be borne in mind that these nematodes are a subject of concern only insofar as they reportedly produce a gummy substance, small quantities of which confer an unpleasant taste to finished water.

The only effective way to remove both the parasitic hookworm and threadworm larvae and the free-living nuisance nematodes from water is to chlorinate heavily, allowing at least 2 to 4 h contact time to immobilize them prior to flocculation and sand filtration. Nematodes are detected by filtering the water sample through a woven nylon strainer of 25 to 30  $\mu$ m pore diameter, then pipetting in phosphate buffer to dislodge them and finally examining the sample microscopically.

d. Gastroenteritis of Undetermined Etiology. Gastroenteritis, resulting in nausea, vomiting, and diarrhea, accounts for over half the reported cases of waterborne disease. The cause of illness cannot be determined in the majority of these cases.

Many causes of gastroenteritis are possible: among them, only the infectious agents are transmitted, with any frequency, by contaminated water or food. Fecally contaminated water is a likely source of these agents since diarrhea is one of the major symptoms of gastroenteritis. Indeed, sewage contamination of drinking water supplies has produced the largest number of documented cases of waterborne disease. Such contamination often results in explosive outbreaks of acute gastroenteritis affecting a large percentage of the individuals who ingest the water.

When gastroenteritis of undetermined etiology occurs in otherwise healthy individuals, it is generally self-limiting; and in the majority of cases, there is no need for medical attention. However, outbreaks that occur among malnourished or otherwise weakened persons can lead, especially when they occur repeatedly, to more serious consequences; as a result, this disease is considered to be a major cause of infant mortality, particularly in the tropics.

(i) Categories and Properties of Agents of Gastroenteritis. Many of the infectious agents which sometimes cause waterborne gastroenteritis are discussed in other sections of this report. Those most often incriminated are enteric bacteria of the genera Salmonella and Shigella [See Sections B.1.a(i) and (ii)], perhaps because these are often the only organisms sought in laboratory investigations of waterborne outbreaks. More extensive investigations may also include testing for enteric viruses [See Sections B.1.b and C.2.b], enteropathogenic E. coli [See Section B.1.a(iv)] and the cysts of Entamoeba and Giardia [See Section B.1.c]. Nonetheless, even when laboratories do thorough tests of diarrheal stool specimens and water samples they usually fail to identify an etiological agent. The illness in such outbreaks is often called "acute infectious nonbacterial gastroenteritis" (AING) if bacteria-free fecal extracts from affected individuals cause gastroenteritis when ingested by volunteers. The agents causing AING therefore were often presumed to be viruses, although laboratories were (and still are) unable to cultivate these presumed viruses. It is only recently that means have been developed for identifying some of the viruses responsible for AING. Most of the viruses that can be isolated from feces by standard cultural methods are not agents of gastroenteritis, but may, however, cause a variety of other symptoms [See Section B.1.b].

(i.1) Parvovirus-Like Agents of Gastroenteritis. A breakthrough in identifying AING agents came in the early 1970's when viral particles were detected in connection with a gastroenteritis outbreak that had a 50 percent attack rate at a school in Norwalk, Ohio, U.S. (Kapikian, et al., 1972). The outbreak was characterized by nausea, vomiting, and stomach cramps, and symptoms typically persisted for 12 to 24 h. Secondary cases occurred in 32 percent of family contacts.

The viral particles were seen by means of immune electron microscopy (IEM) in fecal extracts from a volunteer who had ingested stool filtrates from an outbreak victim. The well from which the school's water was obtained was suspected, but could not be definitely incriminated because the IEM method is not sensitive enough to detect viral particles in environmental samples. The virus was called the Norwalk agent and was characterized as a parvovirus-like 27 nm particle similar in appearance, but unrelated serologically, to the virus of hepatitis A.

Further investigation has revealed similar particles in stool specimens from two separate family outbreaks of AING, one in Montgomery County (U.S.) and the other in Hawaii (U.S.) (Thornhill, et al., 1977). The Montgomery County (MC) agent was found to be antigenically similar and the Hawaii (H) agent dissimilar to the Norwalk agent, suggesting that more than one type of parvovirus-like agent may be associated with AING. This conclusion is supported by work conducted in England where parvovirus-like particles designated "W", Ditchling, and cockle agents were associated with two distinct gastroenteritis outbreaks (Appleton and Buckley, 1977; Appleton and Pereira, 1977). These viruses are similar in morphology, size, and density, but are antigenically dissimilar to the Norwalk agent. They show considerable similarities to enteroviruses and may soon be classified as such. The cockle agent is of special interest because shellfish, the probable vehicle of transmission, were taken from water where sewage pollution was known to occur (Appleton and Pereira, 1977).

(i.2) Rotavirus. A second category of viral agents associated with gastroenteritis also was identified in the early 1970's. Reovirus-like particles were visualized in fecal extracts from infants and young children experiencing diarrheal illness (Bishop, et al., 1973). They were also reported by Riley to be the cause of several non-bacterial diarrheal outbreaks (reviewed in Craun, 1979). These particles have been found worldwide in association with diarrheal disease in infants and young children. They have been

isolated from as many as 75 percent of children with gastroenteritis (Madeley, 1979). Infections appear to be more common during colder winter months. The incubation period is about 48 h and the disease is short-lived; viruses are seldom isolated after the eighth day. Infection normally leads to long-lived immunity.

These viruses are now generally called rotaviruses, although they have also been referred to in the literature as orbiviruses, duoviruses, reovirus-like agents, and infantile gastroenteritis viruses. The human rotavirus, like the parvovirus-like agents, has not yet been isolated in laboratory cell cultures. However, it is often excreted by infected individuals in concentrations sufficient to be detected by direct electron microscopic examination of fecal extracts [See Section B.1.b].

(i.3) Other Viruses and Bacteria Associated with Gastroenteritis. In addition to parvovirus-like particles and rotaviruses, other yet unidentified viruses have been visualized by electron microscopy of diarrheal stools. These include particles resembling coronaviruses, myxoviruses, astroviruses, adenoviruses, and caliciviruses, ranging in diameter from 28 to over 100 nm.

Electron microscopy studies have revealed the presence of adenoviruses in feces, while normal cultural methods yielded negative results. The presence of these adenoviruses has occasionally been associated with mild outbreaks of gastroenteritis (Flewett, *et al.*, 1975). However, it is difficult to assess the extent to which the illness can be attributed to the virus because these viruses have commonly been isolated, using both cultural methods and electron microscopy, from healthy persons. It is not known why some of these viruses apparently cannot be cultured, nor is it clear whether or not the nonculturable strains are of different serotypes.

There is still considerable confusion in identifying viruses in feces, especially when variations in methods, possible artifacts, and the presence of bacteriophages are considered. Furthermore, all of these viruses have been isolated from healthy persons as well as from those with gastroenteritis and, on some occasions, more than one virus has been present. Therefore, the role of these agents in AING is unclear at present, but it would appear that AING might have several viral causes.

Investigations by the U.S. Public Health Service on waterborne outbreaks of acute gastroenteritis have indicated that parvovirus-like agents are most likely responsible for many of these episodes in the U.S. However, the nonbacterial nature of AING outbreaks is sure only in those instances where the disease has been transmitted to volunteers in bacteria-free filtrates of diarrheal stool. The recent association of Yersinia enterocolytica [See Section B.1.a(iii)] and of Campylobacter fetus [See Section B.1.a(viii)] with waterborne gastroenteritis outbreaks in the U.S. (Craun, 1976; Center for Disease Control, 1978b) must also be kept in mind. These bacteria are more difficult to cultivate in the laboratory than are the more familiar enteric bacterial pathogens and tests for their presence are not routinely conducted. For this reason they may sometimes be responsible for outbreaks that are mistakenly designated AING.

(ii) Conclusion and Recommendations. Now that electron microscopic and serologic procedures are available to detect them, it is clear that there are indeed viruses capable of causing AING. As more information is forthcoming, many once unidentified infectious agents will probably be classified as identifiable viruses. For example, infections now known to be caused by rotaviruses can no longer be referred to as "gastroenteritis of undetermined etiology." The incidence of gastroenteritis viruses in humans and in water and wastewater might be determined better if laboratory means of cultivating these agents could be developed. Meanwhile, culture procedures capable of isolating the less-frequently suspected bacterial causes of gastroenteritis should be employed in investigating all waterborne outbreaks.

## 2. Sources of Waterborne Pathogens

The reservoirs for microbiological diseases transmissible to man, consist of man himself as well as both domestic and wild animals (including some poikilotherms). The microorganisms responsible for causing disease generally are excreted in the feces or urine, whereupon they may gain access to water. If drinking water treatment is inadequate or lacking altogether, these organisms may pass freely into water en route to the consumer, thereby engendering a risk of infection and possibly disease [See Section E].



The human intestines are the source of most of the bacteria [See Section B.1.a], virtually all of the viruses [See Sections B.1.b and B.1.d], and the great majority of protozoan and metazoan parasites [See Section B.1.c] which can be transmitted through water to man. Nonhuman sources are significant for a few waterborne pathogens, as is seen in Table B.2-1.

a. The Role of Man. Pathogenic microorganisms are excreted not only by individuals with clinical symptoms, but also by asymptomatic carriers. The average number of individual humans excreting Salmonella at any given time will vary from < 1 percent to 3.9 percent according to studies conducted in several countries throughout the world [See Section B.1.a(i)]. In a great number of cases, these people were outwardly healthy yet excreted about  $10^6$  organisms per gram of feces.

Enteric viral infections are common in children, especially those under five years of age. The high frequency of occurrence is obscured by the fact that only a small percent of those infected manifest serious disease. Prior to the introduction of the poliovirus vaccine, it was estimated that only one of every 1,000 children infected with the wild virus contracted paralytic disease (Melnick and Ledinko, 1951). A similar ratio probably exists for many of the other enteric viruses, therefore, an indication of the prevalence of enteric viruses in a community must be determined from viral excretion data. A recent study conducted in Seattle, Washington (U.S.) indicated a rate of virus isolation in feces (excluding poliovirus) of 2 to 4 percent among family members selected for the study (Cooney, et al., 1972).

Poliovirus isolates were eliminated from the evaluation because they were assumed to be primarily of vaccine origin. Gelfand and colleagues (1957) in earlier work in Louisiana found that as many as 16 percent of the healthy children included in their study were excreting other than polioviruses during the summer months. They also found excretion rates to be inversely related to socio-economic status. Interestingly, Chin and coworkers (1967) were able to demonstrate the presence of vaccine strain poliovirus in sewage when as few as 0.3 percent of the local population has received the live-virus vaccine shortly prior to the examination of the sewage. The Seattle study also found that children less than one year of age had an average of 1.5 enteric viral infections per year which dropped to 0.58 for those two to

TABLE B.2-1

## SOURCES OF WATERBORNE PATHOGENS

Agent	MAN			Multiplication Outside Human Host	Major Animal Reservoir Other than Man	Domestic Animals	WILD ANIMALS	
	Patients	Healthy Carriers	Typical Average per g of Feces fr. an Infected Person				Mammals & Birds	Reptiles, Fishes, Shellfish
<b>BACTERIA</b>								
<u>Salmonella typhi</u>	+	+	10 <sup>6</sup>	+(food)	-	-	-	-
Other salmonellae	+	+	10 <sup>6</sup>	+(food)	+	+	+	+
<u>Shigella</u>	+	+	10 <sup>6</sup>	+(food)	-	-	-	-
<u>Yersinia enterocolitica</u>	+	+	10 <sup>5</sup>	? (food)	+	+	+	-
Enteropathogenic <u>E. coli</u>	+	+	10 <sup>8</sup>	+	-(?)	+	?	-
<u>Francisella tularensis</u>	+	?	?	?	+	+	+	-
<u>Leptospira</u>	+	?	?(urine)	-	+	+	+	-
<u>Vibrio cholerae</u>	+	+	10 <sup>6</sup>	unlikely	-	+(?)	-	+(?)
<u>Campylobacter fetus</u>	+	?	?	?	+	+	+	-
<u>Pseudomonas aeruginosa</u>	+	+	10 <sup>8</sup>	+	-	+	?	+
Other opportunistic pathogens	+	+	10 <sup>6</sup> -10 <sup>8</sup>	+	-	+	?	+
<b>VIRUSES</b>								
Enterovirus	+	+	10 <sup>6</sup>	-	-	-	-	-(?)
Hepatitis A	+	+	10 <sup>6</sup>	-	-	-	-	+
Rotaviruses	+	?	10 <sup>9</sup>	-	-(?)	+	?	-
<b>PARASITES</b>								
<u>Entamoeba histolytica</u>	+	+	10 <sup>5</sup>	-	-	-	-	-
<u>Giardia lamblia</u>	+	+	10 <sup>5</sup>	-	-(?)	+	+	-
<u>Naegleria fowleri</u>	-(?)	-	?	+	-(water)	-	-	-
<u>Acanthamoeba</u>	-(?)	+	?	?	-	-	-	-
Nematodes/Helminths	+	+	10-10 <sup>2</sup>	+(*)	+	-	+	+

+ In some cases Yes, in some cases No.

\* = Presence of an intermediate host.

five years of age and fell considerably lower for those over five [See also Sections B.1.b and B.1.d].

Protozoan cysts are passed in the feces of asymptomatic carriers or patients with chronic or mild cases of amebiasis. Patients with acute dysentery shed trophozoites that are non-infectious. Asymptomatic carriers of the protozoon E. histolytica usually outnumber those with symptomatic amebiasis. In the U.S., where the 1976 carrier rate for E. histolytica was 0.6 percent (Center for Disease Control, 1978a), there is evidence of one clinical case for every 500 carriers. Horster (1943) reported that many German soldiers who developed amebic dysentery in association with bacillary dysentery [See Section III.b.1.a(ii)] in North Africa had been E. histolytica carriers for years before in Germany. Likewise, Wenyon (1947) hypothesized that the 1933, Chicago epidemic of amebic dysentery was, in fact, an outbreak of bacillary dysentery in a population with a high rate of E. histolytica carriage. The source, in this outbreak, was traced to cross-connections between sewage and water lines in a hotel (Bundesen, et al., 1936).

Among populations exposed in three separate waterborne outbreaks of amebic dysentery, the percentage of asymptomatic persons passing cysts was quite high: 57 percent of those exposed were found to be carriers in the 1953, South Bend, Indiana (U.S.) epidemic (Offutt, et al., 1955); 62.9 percent in the Chicago epidemic (Hardy and Spector, 1935); and 50 percent in the 1947, Tokyo Mantetsu-apartment-building outbreak (Ritchie and Davis, 1948). Of these subclinical carriers, only a small fraction developed clinical symptoms [See also Section B.1.c(i)].

G. lamblia occurs throughout the world, especially in areas of poor sanitation. In 1948, G. lamblia was estimated to be present in 7.2 percent of the world's population, based on 84 stool surveys. Giardiasis is endemic and primarily asymptomatic in the Canadian arctic and has been reported in as high as 72 percent of Greenland populations. Curiously, Canadian travelers overseas have a relatively high rate of frank giardial illness and experienced a 59 percent morbidity in a recent outbreak among tourists to Leningrad (Center for Disease Control, 1976a). Whether those tourists who were stricken did not have prior exposure, or whether other factors such as variation in virulence were involved, remain matters for speculation and further study. Leningrad tapwater was implicated in a series of outbreaks among U.S. tour groups which visited Leningrad between 1969 and 1973, and which experienced a 23 percent (324 ill) attack rate [See also Section B.1.c(ii)].

It is not known whether there are carriers for Naegleria fowleri [See also Section B.1.c(iii)]. Acanthamoeba species have been recovered from the respiratory tract of healthy individuals and have been found in eye infections (Sotelo-Avilo, 1974; Nagington, 1974). They have also been isolated from throat cultures of asymptomatic children home from camp where activities included swimming [See also Section B.1.c(iv)]. Man can become an intermediate host in the life cycles of nematodes and other helminths and be severely or minimally infected, depending on geography and climate [See also Section B.1.c(v)].

b. The Role of Domestic Animals. Many waterborne human pathogens can be excreted by either sick or apparently healthy animals, such as domestic pets or farm animals. Excellent reviews are given by Reasoner (1977, 1978).

The incidence of Salmonella in dogs ranges from 6.9 to 18 percent; cats, 6.0 to 13.6 percent; pet turtles, 7.3 to 20 percent; and pet birds, 8.3 percent. Studies of large groups of clinically healthy farm animals indicate that Salmonella carrier rate may vary from 1 to 15 percent for sheep, 0.1 to 17 percent for cattle, 2 to 35 percent for pigs, 2 to 4 percent for goats, 22 to 29 percent for chickens, and 0.7 to 37 percent for ducks and geese.

It is well known that enteropathogenic E. coli can cause intestinal disturbance in domestic animals, especially in pigs; it also can be present without any symptomatology. This organism's ability to exchange plasmidic resistance factors with pathogens such as Salmonella and Shigella heightens the disease risk for individuals in close proximity to domestic animal carriers, but there is at least some evidence that enteropathogenic E. coli strains do not pass readily from one host species to another [See also Section B.1.a(iv)].

Yersinia can be derived from pets, cattle, and more frequently, from pigs [See also Section B.1.a(iii)]. Francisella tularensis has been identified in dogs, cats, sheep and horses [See also Section B.1.a(v)]. Studies reviewed by Reasoner (1977) reported the isolation of Leptospira from pet dogs (42 percent), cattle (1.2 and 59 percent), pigs (43 and 70 percent), horses (5 - 74.6 percent), sheep (7 and 65 percent), and goats (25 percent). These animals can become carriers after inapparent or acute infections and shed the bacteria in their urine [See also Section B.1.a(vi)]. Human carriers of Vibrio cholerae serve as the source of new

cases of cholera; and the role of animals, if any, seems to be minimal [See also Section B.1.a(vii)]. It has been suggested, however, that in the absence of human carriers, intermittent excretion of vibrios by cows and chickens may be a source of new infections. Campylobacter fetus can originate from cattle, sheep, pigs, and poultry [See also Section B.1.a(viii)]. Likewise, all opportunistic pathogens, especially the Enterobacteriaceae, can be found in domestic animals [See also Section B.1.a(ix)].

Man is thought to be the only important reservoir for members of the human enteric viruses. However, viruses that appear to be human viral serotypes have been isolated from the feces of domestic animals (Grew, et al., 1970; Graves and Oppenheimer, 1975). It is assumed that these animals are only passive shedders of viruses ingested via grossly contaminated food or water and that the viruses do not multiply in these hosts. Rotaviruses may be an exception to this viewpoint. Serologically related rotaviruses have been isolated from the feces of children, calves, piglets, mice and foals having acute gastroenteritis (Woode, et al., 1976). The role of these animals in the natural transmission of rotavirus disease in man has not been explored. In fact, the role of domestic and wild animals in the transmission of enteric viral disease to man has not been extensively studied, and further work in this area is needed.

Horses, cows, pikas, and sheep were found to be infected with Giardia species, according to unpublished animal surveys conducted in Colorado in 1975 and 1976. Since only one of two Giardia species infects humans, and since sources for these animal infections were undetermined, data from this survey raise more questions than they answer, such as:

- Which Giardia species was involved?
- Was there one source (perhaps domestic sewage) or multiple sources?
- Were there any cross-transmissions?

G. lamblia of human origin has been shown to be highly infectious for dogs (Craig and Faust, 1964), and has been successfully transmitted from man to rats (Hegner, 1930). Conversely, the organism appears to be transmissible from dog to man (Padchenko and Stolyarchuk, 1969). Giardiasis has recently been found to be apparently prevalent in various species of psittacine birds, but any cross-infectivity to humans has yet to be determined (Panigrahy, et al., 1979).

c. The Role of Wild Animals. Wild animals can serve as important reservoirs of some waterborne pathogens. For example, the carrier incidence of Salmonella in grain fed pigeons ranges from 1.4 to 3.8 percent. The occurrence of Salmonella in 6.9 to 26 percent of various species of sea-gulls may be directly related to their scavenger activities in garbage refuse and ocean dumping sites [See also Sections B.1.a(i) and E.1]. Among cold-blooded animals -- notably snakes, turtles, and lizards -- a high incidence of Salmonella (12.7 to 46 percent) may be due to feeding on dung-associated insects or on infected rodents or small birds.

Y. enterocolitica has been identified in several wild mammals including deer, hare, primates, rodents, foxes, rabbits, and wild birds. Contact with feces appears to be the major transmission route. F. tularensis has been identified in rodents, rabbits, voles, muskrats, beaver, deer, foxes, moles, wild birds, and many species of arthropods. There is no good evidence that animal hosts maintain carrier states; however, Bell (1975) demonstrated that rodents with a tularemia-induced nephritis chronically shed bacilli -- a matter of great theoretical interest. Leptospira interrogans has been identified in mice, opossums, field voles, badgers, rats, and squirrels. They constitute a major reservoir for this organism. It has been suggested that contaminated shellfish have served as sources of human infection with Vibrio cholerae (reviewed by Zwadyk, 1976). Campylobacter fetus has been isolated from birds and rats. As yet, there are insufficient data for ascertaining the role of wild animals in disseminating opportunistic pathogens. It appears that wild animals are not involved in the spread of human enteric viruses (including reoviruses and rotaviruses). Giardia lamblia has been recovered from deer, elk, marmots, raccoons, coyotes, beavers, and muskrats.

### 3. Persistence and Death of Pathogens in Water

Water is a hostile environment to most human pathogens which, once introduced, will die at varying rates. This discussion will deal mainly with factors that influence this death rate. The available data are sparse and scattered in the literature. Moreover, much of the data cannot be directly compared because the experimental protocols differ. An excellent review on the spread of pathogens through water was prepared by Geldreich (1972). As the present work is mainly directed towards drinking water, attention will be directed primarily to intestinal pathogens. In addition,

some data on indicator bacteria will be included to elucidate mechanisms of survival or inactivation.

a. Death of Bacteria. Before discussing the various factors that influence the death of pathogens in water, it will be necessary to consider the phenomenon of death itself. This is best done by citing Postgate (1976) who, in a very instructive paper, pointed out that death of a microbe is not the result of aging as it is in macrobes. A microbial cell divides and its contents live on indefinitely; death will occur only as the result of an environmental stress. Death is usually diagnosed retrospectively. That is, a population is exposed to a recovery medium, incubated, and those cells that do not divide to form progeny are considered to be dead. A marginal state exists between life and death, wherein a cell will grow in one recovery medium, but will fail to grow in another. As a consequence the bacterium will be counted as dead, or alive, depending on the experimental procedure.

In food microbiology, the term "sublethal injury" has been introduced to describe this phenomenon. General principles for the recovery (resuscitation) of sublethally injured bacteria have been developed and are reviewed by van Schothorst (1976). Several effects, not directly related to the aqueous environment, will influence the observed death rates in experimental systems. First, a dense population will die more slowly than a sparse one. This is partly because dying bacteria leak small molecules which not only protect neighbors from stress, but can actually be metabolized for further growth. Second, the use of inappropriate diluents can sensitize microorganisms to experimentally applied stresses. Even mild stresses which would normally elicit no reaction could, after an organism was exposed to an overt stress, have a marked effect. For example, E. coli became sensitive to warming at 50°C for 5 min after being starved for two weeks or more in stream water (Klein and Wu, 1974). This suggests that the pour plate method, which entails a certain amount of heat shock when the melted agar contacts the organisms, may be unsuitable for the enumeration of starved bacteria. On the other hand, no increased sensitivity to heat was observed for Aeromonas after starvation. Third, the use of different media, incubation temperatures, etc., will result in the recovery of a different proportion of the sublethally damaged bacteria. Also, the presence in the medium of a limiting nutrient that was lacking in the environmental system may lead to death in part of the population.

b. Factors that Influence the Death of Bacterial Pathogens. It has long been recognized that bacterial death is influenced by a number of factors (Rudolfs, et al., 1950a), some of which will be considered here.

In general, death rates increase with increasing temperatures (McFeters, et al., 1972; Mitchell and Starzyk, 1975; and Verstraete and Voets, 1976). Death rates in summer are higher than in winter, not only because of higher temperatures but possibly from the action of sunlight. Even though close correlations between the death rate and insolation or ultraviolet solar radiation have been found, it is impossible to distinguish between the direct effects of sunlight and the many indirect effects such as heating, promotion of algal growth, etc. (Verstraete and Voets, 1976; Calkins, et al., 1976) [See Section E.1].

It is well known that pathogens prefer conditions close to neutrality and survive best between pH values of six and eight. High acidity or alkalinity are deleterious, and sudden changes in pH from neutrality to either acidity or alkalinity accelerate the death rate considerably. Hanes and coworkers (1964) performed detailed studies and confirmed the earlier evidence that indicator bacteria survive better under aerobic than under anaerobic conditions.

The role of nutrients in bacterial survival in water is complex. High nutrient levels (as would occur in sewage effluent or fecal suspensions) may prolong survival (Tannock and Smith, 1971) or even promote bacterial growth. On the other hand, nutrients can also encourage the growth of bacterial predators (Kittrell and Furfari, 1963). Low nutrient levels will generally result in bacterial reductions as has been shown in numerous papers. Wuhrmann (1972) stated that pathogen multiplication is negligible in environmental waters where nutrients are sparse, although Cherry and coworkers (1972) found Salmonella in 44 percent of apparently unpolluted waters. This could have been a consequence of the high Salmonella carrier rates in birds and wild animals [See Sections B.1.a(i) and B.2].

The ecosystem of a receiving water has an inherent capacity to restore conditions to their previous norm. One important mechanism is predation by protozoa such as Vexillifera (Mitchell, 1972) and Colpoda steinii (Drake and Tsuchiya, 1976), and another is competition and antagonisms from the indigenous aquatic flora. Bacteriophages are frequently mentioned as important contributors to bacterial



die-off but no data have been published to confirm this hypothesis. Algae and cyanophages can also enhance bacterial death by a number of poorly understood mechanisms, including production of antibacterial substances (also true with higher plants), changes in pH, and limitation of carbon dioxide (reviewed by Davis and Gloyna, 1972). Filtration or autoclaving (the more efficient of the two) of raw river water removed its bactericidal effect on Shigella flexneri (Mohadjer and Mehrabian, 1975). Another indirect indication for the role of predators is the influence of stream morphology. In general, death rates in small streams (with a great surface-to-volume ratio) will be greater than those in large streams (Kittrell and Furfari, 1963; Wuhrmann, 1972).

c. Survival of Bacterial Pathogens in Water. The following data were obtained by investigators using different experimental procedures and are not meant to be construed as a basis for quantitative comparisons between pathogens.

The survival of Salmonella after having entered a receiving water depends upon several conditions. Salmonellae were regularly detected in surface water up to .25 km downstream from a wastewater treatment plant, but never at sample sites 1.5 to 4 km downstream (Kampelmacher and van Noorle Jansen, 1976). In this case, dilution was the main factor in reducing bacterial numbers. Salmonellae, transported by stormwater through a wastewater drain at a University of Wisconsin experimental farm, were isolated regularly .8 km downstream of a swimming beach (Claudon, et al., 1971).

Laboratory experiments suggest that cold water and available nutrients in wastes are critical to Salmonella persistence. When S. typhimurium was held in samples of river water, 90 percent reduction took place in 13 days at 5°C, five days at 20°C, and two days at 30°C (Ahmed, 1975). Ruys (1940) isolated Salmonella typhi from water in winter but not in summer. Studies of ice covered rivers showed survival times of from four to seven days (Spino, 1966; Davenport, et al., 1976).

Salmonellae were isolated during September from the Red River of the North, 36 km downstream of sewage discharges from Fargo, North Dakota, and Moorhead, Minnesota (U.S. Department of Health, Education, and Welfare, 1965). By November, salmonellae were found 100 km downstream of these

two cities. High levels of bacterial nutrients entered the river under ice cover during a January peak in sugar beet processing and accompanying waste discharges. Salmonella strains were then isolated 118 km downstream (or four days' flow time) from the nearest sources of warmblooded animal pollution. Similarly, water samples taken from the Vltava and Danube rivers, polluted with sugar beet wastewaters, supported Salmonella growth even when diluted 1,000-fold at 20°C and 30°C (Adamek, et al., 1977).

On the other hand, Shrewsbury and Barson (1952) conducted experiments which showed that Salmonella survives longer in pure water than in water containing dissolved inorganic substances. They inoculated  $5 \times 10^8$  and  $10^9$  S. typhi per ml into tapwater, distilled water, and normal saline. Samples were kept in daylight at temperatures between 7.2 and 35°C (mean, 21.1°C) under aerobic conditions. Viable organisms were recovered for up to 211 days in tap water, up to 443 days in distilled water, but only up to 153 days in normal saline.

Shigella flexneri survived more than a month at -8°C in tap water, but untreated river water was bactericidal for S. flexneri at 4 to 6°C and 23 to 25°C (reviewed by Reasoner, 1977).

Whereas most bacterial pathogens appear to show some similarity in survival rates in water, the stability of Y. enterocolitica in water differs considerably from that of the other Enterobacteriaceae. Y. enterocolitica is better able to survive in nature than are other human pathogens because it prefers lower temperatures (~20°C optimum). It has been hypothesized (Kristensen, 1977) that the ability of Y. enterocolitica to multiply at 4°C may explain its apparent increased occurrence in industrialized countries where refrigeration is used extensively. Dominowska and Malottke (1971) found that Y. enterocolitica survived longer in autumn and winter than in spring and summer, and that it survived for as long as 157 days in water free of other microorganisms. Krogstad (1974) found that during the first few hours and days in water, Y. enterocolitica and E. coli were reduced at nearly the same rate, but that Y. enterocolitica survived longer than E. coli at low temperatures. In seawater held at 15°C, the survival time was nearly the same for Y. enterocolitica serotype 0:3, Y. enterocolitica of the type frequently isolated from water (and showing an atypical rhamnose-positive reaction), and E. coli (Kristensen, 1977).

But, at 6°C, both Y. enterocolitica types persisted considerably longer than E. coli. Schillinger and coworkers (1978) found that Y. enterocolitica survived longer, compared to E. coli, in oligotrophic stream water at temperatures of 5.0 to 8.5°C. On the other hand, Y. enterocolitica died at a faster rate than E. coli in a continuous flow of chlorinated tap water.

Y. enterocolitica has also been shown to grow under low nutrient conditions. Highsmith and coworkers (1977) reported growth of Y. enterocolitica in sterile distilled water at 4, 25, and 37°C, but not at 42°C. Optimum growth was at 25°C. After 18 months of storage at 4°C, the flasks still contained  $10^6$  cells per ml.

According to Hopla (1974), whether or not tularemia organisms persist in water over long periods has not been satisfactorily resolved. Hopla described tests performed by Bell wherein he found that F. tularensis isolated from streams grew poorly or not at all when incubated at stream temperatures. Parker and coworkers (reviewed in Hopla, 1974) recovered F. tularensis over a 16-month period in certain areas of northwestern U.S. and postulated that specific properties of mud and water enhanced the organism's survival potential.

Enteropathogenic E. coli, unlike the non-pathogenic E. coli types, does not appear to survive long in water; whereas E. coli can persist in water for over 60 days, enteropathogenic E. coli dies within ten days, and this may be why it is very rarely isolated from environmental waters (Müller, 1967).

Survival of Leptospira is enhanced by temperatures of 22°C or above and a neutral to slightly alkaline environment [See Section B.1.a(vi)]. Vibrio cholerae survives best at low temperatures, but only at a neutral or alkaline pH [See Section B.1.a(vii)]. There is no information as yet on the survival of Campylobacter [See Section B.1.a(viii)] in water, nor are there any precise quantitative data for survival of opportunistic pathogens in water [See Section B.1.a(ix)].

The most promising types of experiments comparing pathogen survival in water appear to be based on the membrane filter chambers described by McFeters and coworkers (1974). Table B.3-1 summarizes results from these experiments on survival of different bacteria in well water at 9.5

TABLE B.3-1

COMPARATIVE DIE-OFF RATES OF  
FECAL INDICATOR BACTERIA AND ENTERIC PATHOGENS

Bacterial Species	Half-Time (Hours)*
<u>Aeromonas</u>	no death
<u>Shigella</u>	22 - 27
Enterococci	22
<u>Salmonella enteritidis</u> ser. paratyphi D	19
Coliform bacteria	17
<u>Salmonella enteritidis</u> ser. paratyphi A	16
<u>Salmonella enteritidis</u> ser. typhimurium	16
<u>Streptococcus equinus</u>	10
<u>Vibrio cholerae</u>	7
<u>Salmonella typhi</u>	6
<u>Streptococcus bovis</u>	4
<u>Salmonella enteritidis</u> ser. paratyphi B	2

\*The time required for a 50% reduction in the initial population.

Taken from: McFeters, et al., 1974.

to 12.5°C. In particular, the longevity of Shigella species is striking and should be of concern to water hygienists.

In recent years, several workers have shown that bacteria can sustain sublethal injury after starvation in the aqueous environment. Hoadley and Chang (1974) found counts of P. aeruginosa, S. faecalis, and E. coli on selective media to be consistently lower when these organisms were suspended in tapwater than when they were suspended in stream water or 0.1 percent peptone water (both containing ~550 mg per l of organic carbon). Bisonnette and coworkers (1975; 1977) studied the effect of environmental stress using membrane filter chambers. Both survival and death of E. coli and S. faecalis were found to be dependent on water quality as reflected by differences between eight sampling points. In general, the percentage of sublethally injured bacteria increased with time. Resuscitation for 2.5 to 3 h in enriched Trypticase Soy Broth was sufficient to restore the cell's ability to grow in selective media. Andre and coworkers (1967) noted that both colony size and morphology of Salmonella and Shigella grown on SS agar changed with increased exposure to water. Sublethal injury does not only manifest itself in the growth characteristics of a bacterial cell, but in many biochemical characteristics as well, including reduced oxygen consumption and dehydrogenase activity (Daubner, 1975). Oger and coworkers (1976) starved different Salmonella serotypes in river water and found that antigenic properties of the bacteria disappeared after two weeks at a survival of approximately 0.5 percent.

d. Persistence of Viruses in Water. Virus persistence in water has been the subject of a number of reviews. Clarke and colleagues (1964) reviewed the early literature that was published after the introduction of tissue culture techniques. A more recent summary of results appears in Table B.3-2.

There is no difference in opinion among the various authors on the role of temperature: lower temperatures favor persistence, whereas virus inactivation is accelerated at higher temperatures. The following features also are generally agreed upon: (1) viruses persist longest in distilled or deionized water; (2) viruses persist longer in autoclaved drinking water than in autoclaved river water; (3) viruses persist longer in water heavily polluted with sewage, in autoclaved and filter-sterilized river water, in tap water, and in distilled water than they do in untreated

TABLE B.3-2

## PERSISTENCE OF SOME ENTEROVIRUSES IN WATER

Type of Water	Viruses	Estimated Days before 99.9% Titer Reduction at a Temperature of			
		4 - 6°C	15 - 16°C	20 - 25°C	
Sea or estuary	Coxsackie B1, B3	90	8 - 14	2 - 28	
	Echo 6	30 - 88	15 - 16	4 - 15	
	Polio 1, 2, 3	30 - 130	8 - 15	2 - 8	
River	Coxsackie A2, A9, B3, B5	10 - 75	8	2 - 8	
	Echo 6, 7, 12	15 - 60	15	3 - 16	
	Polio 1, 2, 3	19 - 75	8 - 45	3 - 20	
Impounded fresh	Coxsackie A9, B3	6 - 18	-	3 - 6	
	Echo 6, 7, 12	5 - 42	-	4 - 24	
	Polio 1, 2, 3	21 - 52	-	3 - 22	
Tap	Coxsackie A2, A9	98	-	15 - 100	
	Echo 7, 12	85 - 130	-	10 - 11	
	Polio 1, 2, 3	140 - 168	-	95	
Deionized or distilled	Coxsackie B1	-	-	5	
	Echo 6	-	-	14	

Modified from Akin *et al.*, 1977.

environmental water, regardless of temperature; and (4) , enteroviruses persist longer than E. coli in water.

Apart from the seeming paradox of prolonged survival in water heavily polluted with sewage, the evidence suggests that the cleaner the water, the longer the survival time [See also Sections B.1.b and C.2.a to b].

e. Survival of Parasites in Water. Recently, a cesspool in Amersfoort (Netherlands) was uncovered that had been in use at a monastery around the year 1600. The material was almost free of bacteria, except for some anaerobic sporeformers, but it contained large numbers of Ascaris and Trichuris eggs (van Knapen, 1978). Although none of these eggs were viable, this observation indicates that parasitic eggs are very stable. The same holds true for parasites in water, as concluded by Rudolf and coworkers (1950b). Both protozoan cysts, such as those of Entamoeba histolytica, and parasitic eggs can still retain their infectivity for weeks or even months in water (reviewed by Geldreich, 1972) [See also Section B.1.c].

f. Conclusion. The fate of pathogenic organisms in water is subject to a great many influences including temperature, nutrients, pH, indigenous and accompanying flora, and a number of others. Furthermore, some pathogens under certain conditions persist longer in water than the standard bacterial indicators. Therefore, once a source water has been contaminated, specific treatment to remove pathogens is warranted; it is not enough to rely solely on natural die-off during storage.

#### 4. Infectivity of Waterborne Pathogens

The presence of a viable, pathogenic microbe in drinking water is always undesirable, but it does not always guarantee that infection, and especially disease, will result if someone drinks the contaminated water. There is a paucity of information concerning the infectivity of waterborne pathogens. Information that is available is mainly based on controlled feeding studies of healthy unstressed volunteers and probability of illness studies by Dudley and coworkers (1976). Dudley's work indicated that if a person were to swallow 506 S. typhosa, there would be a 0.0051 percent probability that illness would ensue, and that if

219 S. typhosa were swallowed, the probability of illness occurring would be .0003 percent.

For the present purpose, an ideal study would have been one in which a fully virulent infectious agent was administered to a large number of human volunteers representing a broad range of ages, if not states of health. The agent should have been administered with drinking water and the dose determined in terms of some absolute unit such as viable bacterial cells, viral particles, or protozoan cysts. Each recipient should have been observed carefully to determine whether infection (as contrasted to illness) occurred and, if illness resulted, the length of the incubation period and the duration and severity of the symptoms. A few studies with human subjects may have met one of these stipulations -- almost none seems to have met more than one. Obviously, there is a great need for research in this area. Unfortunately, it is extremely difficult to determine absolute numbers of agents such as virus particles in an administered dose; and it is virtually inconceivable that infants or the elderly would be used in this type of research, especially as recipients of virulent infectious agents.

The probability that a given agent will cause infection if ingested with drinking water is, almost certainly, a function of the dose; however, the mathematical nature of the function is not known and may well not be the same for all kinds of infectious agents. Mathematical rigor, in the analysis of results of studies to date, is discouraged by uncertainties in the measurement of administered dose. It seems safe to say that the probability of becoming infected is a function of dose ingested, but it is by no means clear that the probability of becoming overtly ill is enhanced by ingesting some dose greater than that which would have produced infection. If an agent is competely attenuated, no multiple of the infectious dose should produce disease. If an agent is virulent, the probability that it will produce disease may be a function of ingested dose, of host factors, or of a combination of the two. Inasmuch as most studies with human subjects have looked only for illness or only for infection, depending on the agent studied, the gaps in present knowledge are not surprising.

The data given in Table B.4-1 have been compiled by Bradley and Feachem (1979) and are presented on the premise that some information is better than none. The studies from which these numbers derive are inevitably subject to the limitations discussed previously, so the data must not be



TABLE B.4-1

MEDIAN PERORAL INFECTIVE DOSE OF  
WATERBORNE PATHOGENS CITED IN THIS SECTION

	Quantity Needed to Infect 50% of Human Volunteers
<b>BACTERIA:</b>	
<u>Salmonella</u>	$\sim 10^6$
<u>Shigella</u>	$10^2$ -- $10^4$
<u>Yersinia</u>	$10^6$ or more
Enteropathogenic <u>E. coli</u>	$>10^6$ -- $10^7$
<u>Francisella tularensis</u>	?
<u>Leptospira</u>	$<10^2$
<u>Vibrio</u>	$10^4$ -- $10^6$
<u>Campylobacter</u>	?
Opportunistic pathogens ( <u>Pseudomonas</u> )	?
<b>VIRUSES:</b>	
Enteroviruses	$<10^2$
Hepatitis A virus	$<10^2$
Rotavirus	$<10^2$
<b>PARASITES:</b>	
<u>Entamoeba histolytica</u>	$10^5$
<u>Giardia lamblia</u>	$10^5$

Taken from: Feachen et al., 1978.

taken too seriously either as absolute or relative predictors. A look at research on peroral virus infection illustrates these points.

There have been a few published studies regarding the infectivity of ingested poliovirus (reviewed by Safe Drinking Water Committee, 1977), but none on pathogenicity. Each was done with oral poliomyelitis vaccine virus and was subject to the criticisms that: (1) the attenuated virus may not be representative of "wild" types occurring in water and wastewater; and (2) the quantities of virus administered to the human subjects were measured in tissue culture infectious doses, rather than in numbers of particles, so that all of the results are expressed in relative terms. The results of the various studies appear to differ by as much as a factor of 100,000 in the relative infectivity of virus in the body and in tissue cultures. Nothing in these findings rules out initiation of an infection, either in a tissue culture or in the body, by a single virus particle: they do suggest that the probability of this happening is quite small in a tissue culture and smaller still in the human body. There are no data available on the relationship of viral dose to pathogenesis.

The incidence of waterborne disease in most industrialized nations appears to be quite low. The potential practical use of further studies with human subjects would be to allow more accurate assessment of the risk to public health associated with a given level of a pathogen in drinking water. In theory, an accurate set of risk assessments could be used by a government to array its public health resources in a way that would minimize transmission of infectious diseases by all routes, including the water vehicle. However, it must be recognized that there are at least two limitations to applying data on the infectivity of waterborne pathogens in this way. First, the data cannot be used to justify intensification of water treatment so as to reduce the concentration of a pathogen to some tolerable level: the presence of pathogens is not tolerable at any level, though there are, of course, practical limits to what can be done to ensure their complete absence. Second, most known outbreaks of waterborne disease have resulted from episodes in which the water produced during some short period had not received any treatment or in which properly treated water became contaminated by raw sewage during distribution: in such instances the outbreak results from the incident, and the precise level of contamination with the pathogen is not a preeminent concern. In summary, there

is a need for more information concerning the peroral infectivity of waterborne pathogens, but it is clear that such information can produce only limited changes in the practice of drinking water treatment and distribution and that it is unlikely to lead to testing water for pathogens rather than indicators in routine surveillance.

#### 5. Epidemiology of Waterborne Infectious Diseases

An infectious disease should be designated "waterborne" only if water has, in fact, served as the vehicle of transmission for the infectious agent. A distinction should be made between waterborne diseases and water-associated diseases. Describing a disease as waterborne in a general sense implies that water is a principal means of its transmission. The role played by water in the transmission of certain infectious agents has been overstressed at times to the point of being quite unrealistic (Henderson, 1968).

This discussion concerns the epidemiology of waterborne diseases, that is to say, the rates of infection and characteristics of the diseases principally associated with waterborne transmission in developed countries. There is a great difference between the situations in developed and developing countries. In many developing countries worldwide, more illnesses and deaths result from sheer lack of availability of water in quantities sufficient for personal and household hygienic uses than from impurities in drinking water. These deficiencies in quantity or availability, along with malnutrition and lack of medical care, are responsible for the millions of deaths ascribed annually to diarrhea and enteritis, which are water-associated, but much less commonly waterborne.

In developed countries, the quantity of water available for drinking and hygienic purposes is sufficient; the nutritional status and medical care are generally good, and the incidence of waterborne disease is low, due to more than a century's progress in sanitation. The epidemiological data all agree that there has been a dramatic regression of classical waterborne disease. For example, in the U.S. in 1908, 40 percent of the typhoid was transmitted via drinking water, compared to 1.4 percent between 1946 and 1964.

There is an important further distinction to be made between the waterborne diseases transmitted by drinking water and contaminated drinking water. Contaminated drinking water is drinking water, having been made potable according to accepted hygienic standards, that is later contaminated accidentally with wastewater. Such contamination

accidents have the potential of producing epidemics that include thousands of cases; whereas the extremely low numbers of infectious agents that might be present in uncontaminated drinking water, after proper treatment and disinfection, are unlikely to produce an appreciable incidence of disease. A third possibility is that untreated or inadequately treated water has been distributed still carrying significant levels of pathogens that were present in the source waters; as will be shown, substantial outbreaks have occurred in this way.

a. Reported Outbreaks of Waterborne Infectious Diseases.

The classic and traditional waterborne diseases -- typhoid fever, bacillary dysentery, and cholera -- have declined considerably in the developed countries. Development of methods for treatment and disinfection of drinking water, as well as construction of wastewater treatment facilities, has made it possible to safeguard against contamination of drinking water with bacteria of fecal origin, except in a few extraordinary cases. Hence, in the developed countries the majority of bacterial disease outbreaks reportedly associated with water consumption have not arisen from a state of endemicity in the population; rather, they have occurred as small localized outbreaks resulting from a temporary deficiency in water treatment or distribution.

Infectious diseases are generally declining in relative importance in developed countries; most of the infectious diseases which are still prominent are not transmitted by the fecal-oral route and are thus unlikely to be waterborne. Whereas bacterial diseases known to be waterborne are definitely less prevalent, the same may not be true for viral diseases. Hepatitis A, which is sometimes transmitted through water, shows a fairly constant overall incidence in the U.S. for the past several years (Center for Disease Control, 1977a). Laboratory methods by which the viral etiology of some gastroenteritides can be confirmed are so new that trends in annual incidence cannot be examined. A fundamental difficulty in comparing the incidence of diseases is that all of them tend to be underreported, in varying degrees, to the agencies that are charged with compiling statistics. This applies to diseases in general and to waterborne diseases in particular.

(i) Incidence in the U.S. The most complete data on waterborne disease are those reported for the U.S. by the Center for Disease Control and the Environmental Protection

Agency (Craun, 1978). During the period 1971 through 1975, 123 waterborne outbreaks, resulting in almost 28,000 cases of illness and perhaps two deaths, were documented in the U.S. [See Table B.5.a-1]. The three largest outbreaks involved municipal water systems: Sewickley, Pennsylvania (5,000 cases of gastroenteritis) in 1975; Rome, New York (4,800 cases of giardiasis) in 1974; and Pico Rivera, California (3,500 cases of gastroenteritis) in 1971.

The mean annual number of waterborne outbreaks reported in the U.S. during 1971 through 1975, was 25. This is twice as many outbreaks as the mean annual number reported during the period 1951 through 1970, and equals the mean annual number reported during the period 1920 through 1936. The reason for this apparent increase in number of outbreaks is difficult to ascertain but is thought to be primarily the result of increased reporting and surveillance activities.

An etiologic agent was implicated in only 49 percent of the outbreaks (including just 36 percent of the cases) from 1971 through 1975. Among these, 12 outbreaks (511 cases) were attributed to chemical poisoning. Outbreaks of infectious diseases included 21 (4,062 cases) caused by the Enterobacteriaceae (shigellosis, typhoid, other salmonellosis, and enterotoxigenic *E. coli*), 14 outbreaks (368 cases) of hepatitis A, and 13 outbreaks (5,136 cases) of giardiasis.

(ii) Water Systems Involved in Outbreaks. Water systems may be classified as municipal, semipublic, or individual. Municipal water systems are defined as public or investor-owned water supplies that serve communities. Individual water systems are those used exclusively by single residences or by persons traveling outside of populated areas. Semipublic water systems, located in areas not served by municipal systems, are developed and maintained for a group of residences (e.g., subdivisions and trailer parks) or at locations where the general public has access to drinking water (e.g., industries, camps, parks, resorts, institutions, and hotels).

The 123 waterborne outbreaks were classified by type of water system [See Table B.5.a-2]. More outbreaks occurred in semipublic water systems (57 percent) than municipal systems (30 percent) or individual systems (13 percent); however, outbreaks in municipal systems affected an average of 504 persons compared to 129 persons per outbreak in semipublic and nine persons per outbreak in individual systems. Therefore, most of the illness (67 percent) resulted from outbreaks in municipal systems.

TABLE B.5.a-1

## WATERBORNE DISEASE OUTBREAKS IN THE U.S., 1971-1975

	1971	1972	1973	1974	1975	Totals
Outbreaks	19	29	26	25	24	123
Cases of illness	5,182	1,638	1,774	8,356	10,879	27,829

From Craun, 1978.

TABLE B.5.a-2

WATERBORNE OUTBREAKS IN THE U.S.,  
1971-1975, BY TYPE OF SYSTEM

	Outbreaks	Cases of Illness
Municipal systems	37	18,633
Semipublic systems	70	9,058
Individual systems	<u>16</u>	<u>138</u>
	123	27,829

From Craun, 1978.

(iii) Deficiencies Leading to Outbreaks. Outbreaks of waterborne disease can also be classified on the basis of the kinds of deficiencies in the water supply system that led to transmission of the causal agent. This has been done, for a longer period of U.S. experience and with water supplies categorized simply as public or private, in Table B.5.a-3. One finds again that the greatest number of outbreaks and the greatest number of cases do not necessarily coincide. Whereas contaminated groundwater accounts for the majority of outbreaks (52 percent) and cases (47 percent) involving private systems, most outbreaks (40 percent) involving public supplies resulted from distribution deficiencies, but the most cases (45 percent) associated with public supplies resulted from treatment deficiencies.

It is extremely difficult to attribute disease contracted as a result of consuming contaminated drinking water directly to the discharge of treated wastewater. Communities that knowingly take their drinking water supplies from contaminated (or potentially contaminated) sources normally expend greater efforts to remove microbial pathogens that are expected to be present. The study of outbreaks is seldom sensitive enough to implicate specific sources of pollution, though they are likely to be the same as some of those that give rise to shellfish contamination. That is to say, the discharge to surface waters of untreated or inadequately treated wastewater always carries with it at least some potential for transmission of disease.

b. Risk Assessment. In addition to investigations of outbreaks, the data gathered as a result of epidemiologic surveys can be used as a basis for estimating risks. In some countries, groups such as the Center for Disease Control, Atlanta, Georgia (U.S.) collect data on many notifiable diseases, including several listed previously. Although this type of surveillance suffers from the problem of incomplete reporting, it can be useful in identifying trends and may also be of help in determining the order of magnitude of various risks of disease. These risks can be expressed alternatively as cases per 100,000 population, as percent of population affected, or as a probability of illness in a single individual at risk. The time dimension is normally one year.



TABLE B.5.a-3

## DEFICIENCIES RESULTING IN OUTBREAKS OF WATERBORNE DISEASE IN U.S.

Cause	Public Supply		Private Supply		Total	
	Outbreaks	Cases	Outbreaks	Cases	Outbreaks	Cases
Untreated surface water	19	7,363	38	1,349	57	8,712
Untreated ground water	19	24,402	188	10,816	207	35,218
Treatment deficiencies	35	36,972	64	7,522	99	44,494
Distribution deficiencies	60	12,246	22	994	82	13,240
Miscellaneous	17	1,155	52	2,436	69	3,591
Total	150	82,138	364	23,117	514	105,255

From Center for Disease Control, 1976b, 1977b ; Craun and McCabe, 1973; Craun, et al., 1976.

During the period from 1967 through 1976, 36 to 51 cases of enteric disease per 100,000 population were reported annually (Center for Disease Control, 1977a) (these included amebiasis, aseptic meningitis, hepatitis A, leptospirosis, poliomyelitis, salmonellosis, shigellosis, and typhoid fever, the agents of which may infect perorally after having been shed with feces or urine). About half of the cases were hepatitis A. Even if the reported cases only represent one out of 20 actual cases (Marier, 1977), it is likely that each year less than 1 percent of the U.S. population contracts infectious disease that is characterized as being spread by fecal-oral route. This compares to the rates observed in eastern Europe where reporting is thought to be much more complete (Szmunn and Dienstag, 1971). In 1974, Czechoslovakia reported a rate of about 290 cases per 100,000 population; Poland, 245; and Yugoslavia, 360 (World Health Organization, 1977). Estimates of the proportion of enteric disease that is waterborne range from about 1 to 33 percent (Mosley, 1967; Singley, et al., 1975), so the probability of contracting waterborne infectious disease in any year might range from 0.0001 to 0.0033 per person.

Over the past 30 years there have been over 100,000 reported cases of disease associated with water supply deficiencies [See Table B.5.a-3], or an average of approximately 3,500 cases per year. If one out of 20 are reported, as assumed previously, then this represents 70,000 actual cases or a probability of 0.0003 (1976 U.S. population = 214 million) which is within the range estimated above. For illustrative purposes assume that there are  $10^5$  cases per year in the U.S. This figure can then be compared to average water consumption in the U.S. It has been estimated that the average person drinks about 1.6 l of water per day (Safe Drinking Water Committee, 1977) which yields a national consumption figure of  $1.2 \times 10^{11}$  l per year. This leads to the estimate that there is less than one case of infectious disease for every 1,000,000 l of water consumed in the U.S. It would seem that U.S. water supplies are quite safe in terms of microbial hazards, although this admittedly represents a social judgment.

The purpose of the preceding exercise is to demonstrate that absolute values for risk can be estimated from general disease statistics, albeit not with a great deal of confidence. However, one can gain an idea of the magnitude of the problem in this way. The drawback to this approach is that the value obtained is insensitive to change because of

the high level of uncertainty. There is also no way of knowing what portion of the risk can be attributed to individual sources of infectious agents, such as effluents, although the outbreak record may eventually prove helpful in that regard.

Another approach to determining the risk associated with a given source of infection is to study specific populations that are most likely to be exposed to the hazard. Ideally, the level of the exposure is determined so as to be able to relate it to the observed response. That is to say, it should be possible to demonstrate a dose-response relationship. For sewage and effluents as a source, a declining order of probable exposure to infectious agents might be by way of: occupational exposure in sewers, occupational exposure in sewage treatment plants, shellfish consumption, beach pollution, land irrigation, and drinking water contamination. Studies intended to relate the frequency of enteric disease to some of these modes of exposure are now in progress.

c. Special Problems in Epidemiology of Waterborne Disease. At least two cases of infectious disease must have occurred before an outbreak can be considered to have taken place and a common source of the infectious agent sought. Except in unique circumstances, such as a case of chemical poisoning in which the chemical was identified in the water, a single case cannot be recognized as having been caused by drinking water. The waterborne outbreaks reported above are those in which drinking water has been implicated epidemiologically as the vehicle of transmission of the illness. In most of the outbreaks, the water was found to be bacteriologically or chemically contaminated. Nevertheless, the etiologic agent of the illness was identified in only about half of the reported outbreaks.

(i) Proving Transmission via Water. It is rare that a simple epidemiologic study can, of itself, develop proof of a cause and effect relationship. The strongest proof, of course, is that provided by the time sequence whereby removal of a suspected cause is followed by a reduction in the illness. Even here, however, it may be difficult to insure that an effect will be seen if the disease has a long latent period. False positive results, in the sense that not every event that follows an action has surely been caused by that action, have also to be anticipated.

In that epidemiologic studies are done with people having multiple activities and living in a complex world, many things affect the outcome of exposure to an infectious agent. The essence of a valid epidemiologic study is to compare an exposed group to an unexposed group in which all important factors other than exposure are identical. To find an appropriate control (unexposed) group which meets these needs is sometimes very difficult when the factor to be studied is drinking water. A truly comparable control group may be very difficult to identify when almost everyone is "exposed"!

Furthermore, the nature of a disease may of itself impose difficulties in undertaking prospective studies. For example, the movements of the study population become important problems when investigating a disease with a relatively long incubation period, such as hepatitis A.

In order to prove, irrefutably, that drinking water has acted as a vehicle in transmitting a particular disease agent, it is necessary to: (1) be relatively certain of the presence and levels of potentially pathogenic bacteria or viruses occurring in finished water (taking into account the limits of current techniques); (2) recover these agents from the water; (3) have accurate knowledge of the minimum infectious dose (i.e., to know at least approximately, the numbers of organisms one must ingest to provoke infection and disease); and (4) increase the probability of detecting sporadic and isolated illness in a population by conducting well-planned prospective studies.

(ii) Virus Transmission. The majority of hepatitis A and viral gastroenteritis outbreaks reported have been associated with drinking water supplies which, for reasons of poor management or inadequate or interrupted disinfection, became contaminated with fecal waste. There have not been any reported manifestations of enteroviral disease where the water in public distribution met conventional bacteriological standards of water quality. In view of this epidemiological void, three hypotheses have been offered: (1) either there is no waterborne transmission of virus at all (however, this seems unlikely, given the presence of viruses in wastewater, in surface water, and even in groundwater); (2) the impact to public health of virus transmission through water is negligible; or (3) the current inadequacy of methods of epidemiologic investigation has prevented the gathering of substantial evidence in support of viral transmission through water.

Assumptions have been made that lead to the estimate that one tissue culture infectious unit (TCIU) per 400,000 l would be the maximum level of viruses likely to be present in drinking water under currently accepted treatment and sanitary standards (Environmental Protection Agency, 1978). At this concentration, the residents of a typical city of 100,000 population would be exposed to about 100 TCIU of viruses each day in the water used for domestic purposes based on U.S. average community use of 640 l per person per day and 69 percent residential use (Murray and Reeves, 1977). If we assume that an "average" person drinks about one l of tap water per day, under the circumstances outlined above, one TCIU of virus in infectious condition would be ingested with water by a single individual in the typical city about every four days. The number of cases of clinical disease that would result from the infections produced by this level of ingestion is unknown but would most likely be several orders of magnitude lower than the frequency of ingestion. Factors important in the manifestation of clinical disease from viral ingestion include: (1) the immune state of the consumer as a result of previous exposure to the virus; (2) the number of viral particles required to produce infection; and (3) the virulence of the virus (i.e., the disease:infection ratio).

It is probable that current methods (or the current absence of methods) for obtaining epidemiologic information about a population would not allow detection of waterborne disease occurring at this level. Only in exceptional cases (e.g., when wastewater contamination of a supply is substantial) will numbers of affected consumers be sufficiently high to register epidemiologically as having resulted from a common source.

It also has been suggested that sporadic cases of viral disease may be transmitted indirectly by water supplies. That is, even though the levels of pathogens found in water may not cause disease, they could produce infections which, in turn, are spread through close contact of the infected individuals (Berg, 1973). However, these cases should not be considered as waterborne if there is a probability that the diseased individual could have contracted the infection elsewhere, nor should it be assumed that intervention with the water route of transmission will necessarily reduce the incidence of disease.

Berg (1967) has indicated that it may be impossible to prove, by current epidemiologic methods, that focal viral infections are contracted from water and then spread in a community by person-to-person contact. However, he concludes that, given the uncertainties inherent in the situation, future decision-making must err, if at all, on the side of safety. This point is certainly well taken, but it is also true that decision-making should not take place outside the context of the total picture of community health, including the kinds of illnesses that are really occurring in the population and the kinds of preventive measures (including those unrelated to water) that are most likely to exert a significant beneficial effect. Inasmuch as it may be impossible to demonstrate that focal waterborne infections do or do not occur, the controversy remains unresolved and may be expected to continue so for some time to come.

(iii) Parasites. Amebiasis has long been a major concern, both as regards public health in general and drinking water safety in particular. Certainly there have been enough incidents of Entamoeba histolytica transmission by water to show that the problem is a real one. However, another significant problem that is now being perceived in the U.S. and may be present, though undetected, in other developed countries is that of endemic and sometimes epidemic giardiasis [See Section B.1.c(ii)]. The total incidence of giardiasis in the U.S. may exceed that of amebiasis, but the figures are difficult to compare because amebiasis is a notifiable disease, whereas giardiasis is not (Center for Disease Control, 1977a). There is no doubt that transmission of Giardia lamblia through water is significant in the U.S. As was reported above for the period 1971 through 1975, waterborne outbreaks recorded in the U.S. included 13 of giardiasis with 5,136 cases (Craun, 1978). This was more cases than were attributed to any other waterborne agent, or even to the entire group of Enterobacteriaceae combined. Perhaps significantly, this case total compares to no reported outbreaks of waterborne amebiasis.

Reported outbreaks of waterborne giardiasis in the U.S. appear to have resulted primarily from use of surface water for drinking, after no treatment at all or only chemical disinfection by small municipal or semipublic water systems. Giardia cysts are relatively resistant to disinfection. However, Giardia-free water can probably be produced consistently by complete water treatment, including at least coagulation and sedimentation followed by some form of sand filtration before disinfection. Giardia contamination may not be a problem in groundwater from well-protected sources,

but any surface water should probably be suspected, inasmuch as contamination may sometimes derive from feral, nonhuman reservoirs as well as from wastewater containing human feces. For various reasons, it seems likely that waterborne giardiasis will eventually be shown to occur in other industrialized nations besides just the U.S.

(iv) Antibiotic Resistance in Bacteria. A current major concern with regard to bacteria in drinking water relates to their increasing resistance to antibiotics. Bacterial cells are endowed with a remarkable capacity for accepting genes of other strains, for incorporating these traits, and then transmitting them. Antibiotic-resistant enteric bacteria comprise 0.01 percent to 1 percent of the total flora present in feces (in the absence of antibiotic therapy); they make up 10 percent of cells isolated from urban wastewater, 50 percent of cells recovered from river water, and 82 percent of cells isolated from drinking water (Leclerc, et al., 1977a). It would seem, therefore, that over the years, antibiotic-resistant bacteria have been diffused to and concentrated in water, which might be explained in terms of a strong selective pressure in the aquatic environment. The hypotheses offered to explain this are that antibiotic-resistant bacteria enjoy a selective advantage, or that resistance is transferred directly from one strain to another in water; neither has yet received a direct experimental test.

It appears that in order to determine the seriousness of the risk to public health due to increased antibiotic resistance in waterborne bacteria, it would be necessary to perform a survey calling for collaboration between epidemiologists and public health specialists, water authorities, doctors, pharmacists, and diagnostic clinicians who see patients and isolate organisms responsible for producing disease manifestations. Such a survey ought to take into account the total population of one geographic area. Physicians should report all cases of confirmed infectious illness, especially when symptoms include diarrhea. Pharmacists should record all medicines prescribed to clients for treating infectious illness or diarrhea. Clinical diagnostic laboratories should list organisms isolated from patients on the basis of their antibiotic resistances. For their part, water authorities should analyze water for more than just the standard indicators of pollution. Finally, epidemiologists should seek better ways of ascertaining the role of water in the spread of disease within a population. However,

without substantial financial support and good collaboration among these professions, such a survey could not be conducted.

d. Modeling and Monitoring. An epidemiological model is a conceptual system that operates by resembling the natural course of a disease and its transmission. It incorporates major epidemiological factors that determine the dynamics of the spread of infection. A model necessarily represents a simplification of natural processes; nevertheless, if properly constructed it can simulate the natural evolution of an epidemic or an endemic situation, thus permitting the study of the disease dynamics and the effect of deliberate interventions on the natural course of transmission of the infection and hence, on the incidence of the disease (Cvjetanovic, et al., 1978).

Observations of epidemics of infectious diseases led epidemiologists to the conclusion that they present some regular features and that there must be some definite principles that determine the evolution of infectious processes. Efforts have therefore been made to express, in precise quantitative terms, time-related changes in the dynamics of infections and to formulate a mathematical theory of epidemics. One of the general principles of the mechanism of epidemics was established in 1927 by Kermack and McKendrick in mathematical terms when they formulated their theory of the initial "threshold of density" of susceptible populations as the determining factor in epidemics.

Later models have been proposed for individual diseases on the basis of general theories (stochastic, catalytic, and deterministic models) which are excellently reviewed by Cvjetanovic and coworkers (1978). Some of these models can be applied to diseases transmitted partly through water as well as by food. These models are constructed by identifying categories of individuals and factors that play a well-defined and important role in the dynamics of the disease. In order to make the model relatively simple and manageable it is desirable to eliminate unimportant factors and retain only those that significantly influence the epidemiological processes. It is obvious that the models must be based on the natural history of the disease and should be an expression of that history. The aim of the model construction is to arrive at a system that is able to "mimic" the natural processes, such as the past outbreaks and trends of disease, and thus to simulate various real or hypothetical situations.



(i) Potential for Modeling Waterborne Infectious Disease. The word "model" can take on many meanings. Even when it is clear that one is referring to a mathematical model, the great variety and complexity of models may still make the definition unclear. To many, modeling may seem to be a mathematician's art, interesting, but not very practical. Yet all models have one thing in common: they are attempts to represent reality and as such (if they are logically constructed) may be extremely useful in inferring information about real situations.

To be useful to decision-makers, a mathematical model must incorporate the following features: (1) it must be clearly defined; (2) the assumptions made in its construction must be clearly stated; (3) those variables which have the greatest impact on its output must be identified (sensitivity analysis); (4) data inputs must be carefully selected; and (5) it must be validated (Breidenbach, 1976). As a modeler tries to describe large areas, his model can become very complex; but as long as he adheres to the above tenets, the model should still be understandable to those policy makers who must use it. One of the major advantages of modeling is that it promotes the systematic collection and organization of information. On the other hand, if modeling is to have any practical value, representative field data will have to be collected in quantities sufficient to yield unbiased estimates for use in the model.

A major reason for the apparent difference in the incidence of a disease between areas is often the variation in the efficiencies of passive reporting systems. Several studies have indicated that from 60 to 90 percent of the clinical cases of hepatitis are not reported to health authorities (Center for Disease Control, 1975b; Koff, et al., 1973; Levy, et al., 1977; Liao, et al., 1954; Marier, 1977). During nonepidemic periods as few as 10 percent of the actual cases may be reported (Tolsma and Bryan, 1976). However, with the advent of screening for the hepatitis B surface antigen and the availability of immunoglobulin prophylaxis, it is likely that a higher percentage of cases will be reported in the future (Bernier, 1975). Inasmuch as reporting of even notifiable diseases is clearly inadequate, there is an obvious need for alternate, active methods of gathering data for use in epidemiologic modeling and risk assessment.

(ii) Dose-Response Relationships. One of the more basic approaches to estimating risk is the dose-response relationship which predicts the percent of a population likely to exhibit a specific response (e.g., infection, disease, or death) when exposed to a given dosage of a disease agent. Once this type of information has been obtained for representative populations, all that is necessary to assign risk is to measure the level of exposure to a given agent among the subject population. Further, if the sources of the agent are known, then the risk from each of these sources can be determined. However, there are several limitations to this approach: (1) there are many potential disease agents to be evaluated; (2) there can be a wide range of undesirable responses (for example, variety and intensity of symptoms); (3) it is difficult to measure the concentration of some disease agents; and (4) acquisition of the needed data normally requires experimentation on human beings of varying backgrounds, which has become a visible ethical problem (Katz, 1972).

The response to infection is normally acute and generally can be classified into the various states of: infection, disease, and death. Not all infections result in disease which, in the idealized form, means that the dose-infection curve represents lower doses than the dose-disease curve for a given percent response. The vertical difference between the two curves is a measure of the proportion of the infections that result in disease (for hepatitis A, this ratio is about 1:5 to 1:20). However, it cannot always be shown that a dose larger than that required to cause infection is necessary or more likely to produce disease. At present, very few cases of enteric disease result in death.

(iii) Monitoring Methods. There are, of course, active means of gathering needed data without having to challenge human subjects with infectious agents:

- Monitoring is an integrated system of making observations on health and environmental factors, and of scrutinizing, storing, and retrieving these data for specified purposes of protecting and improving human health.
- Health Surveillance is the closely associated system of collating and interpreting data collected from monitoring programs (and from any other relevant sources) with a view to the detection and evaluation of health problems so as to provide a basis for remedial action.

In addition, monitoring may often prove a valuable tool for the epidemiologist endeavoring to relate exposure to response in order to elucidate the causes of widespread diseases or to explain changes in the total disease and mortality patterns. In regard to vital statistics such as births and mortality, monitoring is already established in all developed and in many developing countries throughout the world, but two-thirds of the world's population still lack adequate birth and death registration. Communicable diseases are subject to surveillance, with the object of alerting public health authorities, even at the stage of suspicion, to take preventive action. Although highly developed computerized systems have been designed to provide the quickest possible warning, simpler systems can be devised to suit the needs and capabilities of the country.

It is possible, in looking at environmental hazards, to study a population of children. They tend to remain in the same area at least for a certain known period of time and since they usually go to school near their homes, it is relatively easy to determine the effect of an environmental factor.

The ultimate in this approach is to study a target population with a history of weak immunologic defenses, one that is easy to keep under surveillance, and one for which the source of drinking water is strictly controlled -- that is to say, a population of infants attending child care centers. By studying a population whose drinking water consumption is restricted to bottled water exclusively, and barring any person-to-person spread, one can obtain a good picture of the impact of a water sample on the health of the consumers.

In comparing different groups of the population exposed to environmental hazards, it is extremely important to choose appropriate control groups. In considering an environmental hazard in an industry, for example, it is possible to examine illness or morbidity among husbands and wives, using the wives as controls. It is unlikely that they will be exposed to the same occupational hazards as their husbands, whereas both are likely to be exposed to the same environmental hazards in their homes.

It is also possible to compare data from epidemiologic surveys of two geographic areas with populations of roughly equivalent size and activity; one in which the drinking water is of poor quality and the other using water of high

quality. By noting whether there has been any increase in the sale of antidiarrheal medications, one can obtain valuable data without requiring that there be notification of disease through official channels. The special merit of this approach is that it does not require direct, conscious participation by the populations that are included in the study.

Otherwise, whatever population is chosen, it is important to investigate that population as completely as possible. Information on those who do not participate is essential; they may, for example, have refused because they are ill or because they fear the consequences of having the disease discovered. Significant bias may be introduced in this way if adequate precautions are not taken.

Once the population has been defined and the variables to measure have been decided, the next step is to collect the necessary information. One method of doing this is by using a questionnaire. This is usually better than a clinical history, which may not identify and record in a repeatable way what the individual actually says. The importance of using a standardized questionnaire has been amply demonstrated; whatever questionnaire is used, it is vital that the sensitivity, specificity, and precision of the individual questions be validated. Interviewing techniques must also be standardized.

Physiological tests are another possible method of obtaining the necessary information. Such tests must be simple and if possible cheap to administer, acceptable to those who receive them, and must produce accurate and repeatable results. They must also be "sensitive" (give a positive finding in those who have the condition under investigation) and "specific" (give a negative finding in those who do not). Physiological tests, capable of direct and rapid assessment of the functional state or normality of any member of a study population, would obviously be of great help in minimizing the subjective aspect of an epidemiologic study. Unfortunately, such tests may not always be readily applicable to studies of enteric diseases. If they were, they would yield results well suited to the application of the threshold, or no-permissible-adverse-health-effects, approach that is the basis for all national regulations establishing drinking water quality standards. That is, exposure limits based on bacteriologic indicators in water are set at levels where no adverse health effect to consumers can be anticipated. This is feasible because the

relationship between the pathogenic bacteria and classical microbiological indicators is fairly well known, but may be insufficient for waterborne diseases because of the low correlation between the presence of bacterial indicators and viruses in water, as will be discussed in Topic C.

e. Summary. An extensive record of waterborne outbreaks of disease in the U.S. indicates that most such incidents have resulted from the use of untreated or under-treated water and from episodes of contamination of drinking water. Inasmuch as comparable records do not seem to be available from other countries, it is not entirely certain that the U.S. experience is typical of other industrialized nations. Better reporting, and recording, of disease outbreaks in other countries would certainly be desirable.

There is continuing concern about the possible incidence of sporadic illness in the consuming public, especially as a result of viruses that might be present at extremely low levels in finished drinking water. Existing systems of compiling disease statistics are passive in the sense that the compilers must wait and hope that clinicians who observe waterborne illnesses will report them. Alternate, active approaches to gathering information on waterborne disease are needed: several possible methods have been discussed in this section.

Meanwhile, decisions regarding drinking water safety and public health must be made with the information that is now available. The epidemiologic record (at least of the U.S.) appears to make a strong case for complete treatment and disinfection of drinking water. "Worst-case" assumptions may lead to predictions that a certain amount of disease will be transmitted even by completely treated water. The public interest may instead lie in determining the validity of these predictions through better epidemiologic work than in devising new water treatment techniques in hopes of solving a problem that has not yet been proven to exist.

## 6. Summary

Drinking water may transmit pathogenic organisms if it becomes contaminated with human or animal feces. Fecal contamination may occur at any point from the raw water source to the ends of the distribution network. If the

pathogens thus introduced are not subsequently removed or destroyed, a result may be that the consumer will ingest some quantity of bacterial, viral, or parasitic organisms. Geographic and epidemiologic conditions, as well as the overall numbers and virulence of the organism ingested, determine the result of such an incident.

a. Microbial Pathogens. The transmission of microbial pathogens through drinking water in industrialized nations has changed with time. Some of the most historically significant waterborne pathogens (notably those that cause typhoid fever, bacillary dysentery, and cholera) have been on the decline in recent years. Other bacteria, all of the enteric viruses, and the protozoon, Giardia lamblia, have evoked more concern of late, probably due instead to greater awareness and better reporting than because they present a greater threat than previously. This trend is associated with the development of better methods of detecting potential waterborne pathogens in clinical specimens and, in some cases, in water samples.

The genus Salmonella is a very large group consisting of 1,200 known serotypes that are pathogenic to humans, causing mild to acute gastroenteritis and very occasionally death. Typhoid fever, caused by S. typhi, and paratyphoid fever, caused by S. paratyphi A or B, are both enteric diseases that occur only in humans. The other Salmonella serotypes are responsible for foodborne illnesses accompanied by mild to acute gastroenteritis, but rarely death. These milder forms are referred to as salmonellosis and occur frequently in humans and wild or domestic animals.

Salmonellae are excreted by infected humans (exclusively so for S. typhi), farm animals, domestic pets, and warm-blooded wild animals. Salmonella strains were regularly found in the sewage system of a residential area of 4,000 persons. Streams, lakes, and rivers receiving discharges of meat processing wastes or effluents of untreated or inadequately treated community sewage may contain substantial numbers of salmonellae. Fish living in polluted water may ingest salmonellae and become vectors of pathogen transport. Drinking untreated, unprotected surface water presents the greatest risk to the consumer. There are presently no standardized methods for isolating salmonellae from water. Since these microorganisms ordinarily occur in lower numbers than those of sanitary indicator bacteria, they must initially be concentrated from large-volume samples of water.

The Shigella genus is divided into four main subgroups. All species cause bacillary dysentery (also called shigellosis) exclusively in humans and some primates. Infection is transmitted by the fecal-oral route: shigellae have been isolated from clothing, toilet seats, and contaminated foods. Infection with Shigella occurs endemically in most communities and may be maintained by a few symptomless carriers in the absence of clinical cases. Stricter sanitation measures, proper sewage disposal, and public health standards enforced in the developed countries have led to a shift in peak incidence from summer to winter, as low temperatures favor survival of Shigella. As with Salmonella, no standardized procedures have been established for isolating Shigella from water.

Evidence of infections due to Yersinia enterocolitica has been mounting since the early 1960's, especially from the world's cold or temperate regions. Yersiniosis is thought to be contracted perorally. Y. enterocolitica has been isolated from lymph nodes and feces of both sick and healthy humans and of a growing number of animal species. Different Y. enterocolitica types have been isolated so frequently from untreated surface water in some areas that they most likely represent part of the normal microbial flora of the water and surrounding terrestrial environments. Reports referring to waterborne Y. enterocolitica infections are few in number. Moreover, Y. enterocolitica grown at 37°C is less resistant to normal cellular bactericidal defenses than when grown at 20°C; this could explain why transmission of infections through direct person-to-person contact is relatively rare, and again, why an intermediate cold phase could be critical to its spread. If so, the life cycle of Y. enterocolitica would stand in sharp contrast to that of others in the family Enterobacteriaceae, which are transmitted through water less frequently than by contact. There is no standard method for the isolation and enumeration of Y. enterocolitica in water.

Transmission of enteropathogenic Escherichia coli through drinking water was frequently reported during the 1950's. Certain enteropathogenic strains of E. coli are now known to cause acute diarrhea, especially in infants, in travelers to foreign countries, and in consumers of contaminated foods. The definition of the coliform group includes E. coli, so enteropathogenic E. coli is unlikely to be present in water in which coliforms are undetectable; this relationship is far more direct than is usual between indicators and pathogens. However, even if E. coli is shown to be

present, its enteropathogenicity can be determined only by highly refined techniques.

Tularemia is a zoonotic disease transmitted to humans from blood-sucking arthropods, domestic animals, and primarily from a number of wild animal species, many of which lead semi-aquatic lives. The causative agent, Francisella tularensis, can be contracted through ingestion and may produce buboes and areas of necrosis in organs and tissues of man and animals. Outbreaks of waterborne tularemia have been reported throughout the U.S.S.R. Recent cases of waterborne tularemia in northern Norway have brought about renewed interest in water as a vehicle of infection in the Scandinavian peninsula. There is no standardized method for the examination of water for F. tularensis.

The genus Leptospira is composed of finely coiled spiral organisms, including a number of strains that cause leptospirosis in humans and many animals. Leptospirosis is essentially a zoonosis that may involve domestic and wild animals in great numbers depending on the climate and available food supply. The organism is maintained in the environment by both carrier and diseased hosts, and transmission is particularly favored by population explosions of animal carriers, especially rats. Human exposure to the disease has been from direct or indirect contact with urine from infected animals. Infections with Leptospira are primarily associated with certain occupations, such as mining, dairy farming, and sanitary engineering. It is associated with drinking water only rarely, when there has been a breakdown in sanitation and public health systems. There is no standard method for isolating Leptospira from environmental sources.

The genus Vibrio comprises a large number of species, only a few of which are of medical importance: V. cholerae and its biotype V. cholerae El Tor cause cholera exclusively in man; V. parahaemolyticus and nonagglutinable (NAG) vibrios can cause cholera-like disease or mild diarrhea in humans, but are not normally transmitted by the water route. Cholera, whether caused by classical V. cholerae biotypes or the El Tor biotype, produces the same clinical symptom, profuse diarrhea. Fecally contaminated water is the primary vehicle of cholera transmission, although vibrios are also spread by a multitude of other routes including food, soiled clothing, flies, and direct person-to-person contact. Cholera vibrios originate from human feces or vomitus. The disease has characteristically been sporadic and endemic in areas of poor hygiene and warm humid climates. However, isolated



cases have been reported in Europe, and the U.S., mainly from importation through tourism. Methods for isolating vibrios from water have not been standardized.

Campylobacter was initially observed as the agent of infectious abortion in cattle; it also may cause gastroenteritis in humans, cattle, sheep, and swine. The organism inhabits the genitourinary and intestinal tracts and is excreted in the feces. Feces from infected humans, animals, and fowl may contaminate surface waters destined to be used for drinking water supplies. If such source waters were inadequately treated, viable Campylobacter cells could, theoretically, gain entry to finished water. At present, there are no standard methods for detecting Campylobacter in water. When such methods become available for routine use, it will then be possible to determine the significance of Campylobacter in water as it relates to outbreaks of water-borne gastroenteritis.

Several other microorganisms present in water can infrequently cause disease, and almost always under unusual circumstances, either in abnormal hosts or in situations where the normal flora have been supplanted. These organisms are called opportunistic pathogens; Pseudomonas aeruginosa is a most notable case in point, along with some Enterobacteriaceae. Opportunistic pathogens are ubiquitous in nature, very resistant in water, and can grow with only a few nutritional requirements. Concentrations of opportunistic pathogens found in drinking water are not normally sufficient to lead to infection in a healthy consumer. Another very important property of these microorganisms is their great ability to accept and transfer plasmids which carry determinants for resistance to antibiotics.

Opportunistic pathogens present in drinking water include the following bacteria: Pseudomonas species, Aeromonas hydrophila, Edwardsiella tarda, Flavobacterium, Klebsiella, Enterobacter, Serratia, Proteus, Providencia, Citrobacter, Acinetobacter and Staphylococcus aureus. Examination of drinking water for the presence of Pseudomonas should be incorporated into routine analyses of the water since suitable methods exist for the enumeration of P. aeruginosa.

Viruses are ultramicroscopic intracellular parasites, incapable of replication outside of a host organism. Great numbers and varieties of bacterial, plant, and animal viruses may be present in both polluted and unpolluted waters. The viruses of greatest concern are those of human origin, which

are capable of infecting and causing disease in humans. In general, they are shed in the feces and are known as the human enteric viruses. Infection usually takes place after viruses are ingested, possibly in contaminated water or food. Except for the hepatitis A virus, the public health significance of human enteric viruses in water remains unclear due possibly to the apparent or latent nature of viral infections and the difficulty of detecting waterborne viruses.

Human enteroviruses include the polioviruses, the coxsackieviruses groups A and B, and the echoviruses. Although large numbers of enteroviruses have been consistently isolated from fecally contaminated water, only a few reports have implicated water as the vehicle of transmission. Hepatitis A is the only form of viral hepatitis known to be transmitted through water, and it is also the most prevalent waterborne disease attributable to a specific etiologic agent. The incubation period of the disease in humans generally ranges from 15 to 50 days, with a median of 28 days. Some people shed the virus in their feces as early as seven days before onset of symptoms; others may transmit the virus without ever becoming perceptibly ill. Attempts to culture the hepatitis A virus in cell lines have consistently failed, so that all available evidence about its transmission by polluted drinking water is obtained from epidemiological studies. Another group of small viruses potentially transmissible through water, some of which may in fact be enteroviruses, are called gastroenteritis viruses. Rotaviruses are primarily associated with gastroenteritis in children. Because rotaviruses may be excreted in very large numbers, they are almost certain to be present in polluted water; there is presently no suitable method for their detection at low concentrations. Reoviruses, adeno-viruses, and adeno-associated viruses can also be found in water.

Because viruses multiply only within susceptible host cells, they cannot increase in sewage. Their numbers are further reduced as a result of sewage treatment, dilution, natural inactivation, and water treatment practices. Therefore, barring gross contamination of finished water, only extremely low numbers of viruses, if any, are likely to occur in properly treated supplies. Large samples of water must be tested to enable detection of whatever low level of viruses might be occurring in any given source water. Adsorption methods employing glass microfibers and glass powder appear promising for handling large volumes of water containing few viruses. Until further information is forthcoming, the public health significance of small numbers of viruses detected in drinking water will remain undetermined, and it should be noted again that the hepatitis A virus cannot be detected in water.

Certain species of protozoa are now an increasing cause of waterborne disease. Entamoeba histolytica causes amebic dysentery, as well as such other clinical manifestations as diarrhea, abscesses of the liver, and chronic infections with minimal symptoms. Improved sanitary sewerage systems have been largely responsible for the curtailment of waterborne amebic dysentery. Another protozoan, Giardia lamblia, now appears to be emerging as a major causative agent of waterborne disease. It was not until 1966 that water was recognized as a vehicle of Giardia transmission; since that time, increased awareness on the part of physicians may have accounted for the more frequent reporting of outbreaks. The overriding point to be emphasized is that outbreaks involving municipal water supplies are associated with surface water sources where disinfection was the only treatment. G. lamblia cysts are not destroyed by chlorination at dosages and contact times commonly used in water treatment. Naegleria fowleri has been recognized as one of the agents responsible for causing primary amebic meningoencephalitis (PAM). Acanthamoeba is also associated with PAM; like Naegleria fowleri, Acanthamoeba species have been isolated from tap water in association with PAM cases. Metazoan parasites that may be transmitted in drinking water are limited to a few nematodes and helminths whose presence in water is only incidental to their life cycles. Standard chlorination is not effective against parasitic or nuisance-causing metazoa discussed in this section. Well-regulated flocculation, sedimentation, and filtration practices afford reliable protection against their occurrence in finished water.

Many causes of gastroenteritis are possible, including bacteria, viruses, and other unknown agents. The illness in such outbreaks is often called "acute infectious nonbacterial gastroenteritis" (AING). It is only recently that means have been developed for identifying some of the viruses responsible for AING, such as parvovirus-like agents, rotaviruses, and particles resembling coronaviruses, myxoviruses, astroviruses, adenoviruses, and caliciviruses.

b. Sources of Waterborne Pathogens. Reservoirs of diseases transmissible to man are man himself, as well as domestic and wild animals. The microorganisms responsible for causing disease generally are excreted in the feces or urine, whereupon they may gain access to water. If drinking water treatment is inadequate or lacking altogether, these organisms may pass freely into water en route to the consumer, thereby engendering a risk of infection and possibly

disease. Pathogenic microorganisms are excreted not only by individuals with clinical symptoms, but also by asymptomatic carriers.

c. Persistence and Death of Pathogens. Water is a hostile environment to most human pathogens which, once introduced, will die at varying rates depending on factors that influence this death rate: temperature, pH, nutrients, and predation. Under certain conditions, some pathogens persist longer in water than the standard bacterial indicators. Therefore, once a source water has been contaminated, specific treatment to remove pathogens is warranted; it is not enough to rely solely on natural die-off during storage.

d. Infectivity of Waterborne Pathogens. The presence of a viable pathogenic microbe in drinking water is always undesirable, but it does not always guarantee that infection, and especially disease, will result if someone drinks the contaminated water. There is a paucity of information concerning the infectivity of waterborne pathogens. The probability that a given agent will cause infection if ingested with drinking water is, almost certainly, a function of the dose; however, many other factors can affect the answer of the ingestor (immunity, nutrition, intestinal flora, intercurrent illnesses).

e. Epidemiology of Waterborne Infectious Diseases. The epidemiology of waterborne diseases in developing countries deals simply with the infection rates and characteristics of the diseases principally associated with waterborne transmission. However, in developed countries, the quantity of water available for drinking and hygienic purposes is sufficient; the nutritional status and medical care are generally good; and the incidence of waterborne disease is low, as a result of more than a century's progress in sanitation. Contaminated drinking water (water that is ordinarily treated so as to be safe to drink, but is accidentally contaminated by wastewater containing feces) is an important vehicle for epidemic outbreaks because of its potential for mass transmission. On the other hand, drinking water that is treated and disinfected so as to contain only a few residual microorganisms might produce only a barely perceptible or imperceptible rate of disease in the consuming population. More recorded outbreaks have been

associated with semipublic water systems than with municipal or individual systems; however, outbreaks from municipal systems have affected more people than those from semipublic or individual systems.

In some countries, an agency collects data on many notifiable diseases, including several previously listed. Although this type of surveillance suffers from the problem of incomplete reporting, it can be useful in identifying trends and may also be useful in determining the order of magnitude of various risks of disease. During the period from 1967 through 1976, in the U.S.A., 36 to 51 cases of enteric disease per 100,000 population were reported annually. About half of the cases were hepatitis A. Even if the reported cases only represent one out of 20 actual cases, it is likely that each year less than 1 percent of the population contracts infectious disease that is characterized as being spread by the fecal-oral route. Estimates of the proportion of enteric disease that is waterborne range from about 1 to 33 percent, so the probability of contracting waterborne infectious disease in any year might range from 0.0001 to 0.0033. Absolute values for risk can be estimated from general disease statistics, but not with a great deal of confidence. One can gain an idea of the magnitude of the problem, however. The drawback to this approach is that the value obtained is insensitive to change because of the high level of uncertainty. Another approach to determining the risk of a given activity is to study specific populations that are most likely to be exposed to the hazard. Ideally, the level of the exposure is determined in order to relate it to the observed response (dose-response relationship).

The record of waterborne outbreaks, even though they are underreported, reveals the most common deficiencies in water supply systems. Contaminated groundwater accounts for the majority of outbreaks involving private systems, whereas water distribution deficiencies are the most common causes among municipal systems. It is extremely difficult to associate the discharge of treated wastewater with disease contracted as a result of consuming contaminated drinking water. It has been suggested that sporadic cases of viral disease may be indirectly transmitted by water supplies. The importance of the so-called "focal infection" (caused by ingestion of water containing extremely low level of virus) in the spread of enteric viral disease in a community has been neither proven nor disproven. This is mainly because epidemiological research methods are not sufficiently sensitive to determine whether or not "waterborne focal infections" occur. In most of the reported outbreaks, the

water was found to be bacteriologically or chemically contaminated. An etiologic agent is determined in about 50 percent of the incidents, but the rate of reporting is very low.

In any individual, the result of ingesting an infectious agent with water will depend on a great many factors. It is rare that a simple epidemiologic study can, of itself, develop proof of a cause-effect relationship. The purpose of an epidemiologic study is to compare an exposed group to an unexposed group in which all factors other than exposure are identical. Finding an appropriate control (unexposed) group that meets these needs is sometimes very difficult when the factor to be studied is water. The nature of the disease sometimes imposes further difficulties in prospective studies, as in the case of hepatitis A, where the long incubation period affords much opportunity for subjects to move about before becoming ill. Efforts have, therefore, been made to derive precise quantitative expressions for time-related changes in the dynamics of infections.

Models are attempts to represent reality, and as such, may be extremely useful in inferring information about real situations if they are logically constructed. To be useful to decision makers, a mathematical model must incorporate the following: (1) it must be clearly defined; (2) the assumptions made in its construction must be clearly stated; (3) those variables which have the greatest impact on its output must be identified (sensitivity analysis); (4) data inputs must be carefully selected; and (5) it must be validated. One of the major advantages of modeling is that it promotes the systematic collection and organization of information.

It is possible, in looking at environmental hazards, to use a population of children. They tend to remain in the same area at least for a certain known period of time and, since they usually go to school near their homes, it is relatively easy to determine the effect of an environmental factor, such as pathogens present in drinking water.

## 7. Recommendations

1. It is not to be expected that community water suppliers will invariably start with pure source water, treat and disinfect it appropriately, and distribute it through a flawless

network. Even where source water is protected, as is true of many groundwaters, disinfection is recommended. This is especially important where finished water is to be stored rather than being used immediately.

2. Aftergrowth of opportunistic pathogens during distribution of finished water should be prevented by maintaining a chlorine residual throughout the distribution network, especially in large systems.
3. More sensitive methods for the detection of waterborne pathogens need to be developed, along with epidemiologic techniques to afford a more precise understanding of the effects of these agents on public health. Especially needed are well-planned prospective epidemiologic studies that are capable of establishing a valid causal relationship between the public water distribution system and the incidence of infection (and not only overt disease) in the consuming community.
4. Other situations in which it would be appropriate to test for pathogens in distribution water are: (a) after contamination is found to have occurred; (b) to trace the source of an outbreak; and (c) in analyzing disinfectant efficiency.
5. Better techniques must be developed for the detection and enumeration of all viruses that may be present in drinking water. Studies are needed to determine the quantities of waterborne viruses that must be ingested to produce infection and disease. Given the lack of correlation between viruses and the bacterial indicator systems, more research on the antiviral effectiveness of various water treatment processes is needed.
6. Epidemiologic surveillance networks should be established to determine the incidence of infections in populations of drinking water consumers, with an eye to either strengthening or relaxing specific standards.

### C. INDICATOR SYSTEMS FOR MICROBIOLOGICAL QUALITY AND SAFETY OF WATER

Good quality drinking water should be free of potentially harmful organisms and substances. Although this continues to be the main concern of drinking water microbiology, there is much more to the quality of drinking water, by present-day standards, than mere harmlessness. Today's good quality drinking water should be of acceptable color, odor, taste, and (if possible) temperature, and should be prepared and distributed under continuously controlled microbiological conditions.

In the present context, "indicator systems" are defined as quality control methods for water procurement, treatment, and distribution, even when these are not directly related to the presence of potential pathogens. In the broad sense, consideration has been given to methods which range from the traditional reliance on fecal indicators, to methods for recovering other more fastidious organisms, to those which employ chemical and physical means of determining microbial populations and activities.

There are few established routine methods for detecting human pathogens in drinking water due to the large diversities and low numbers encountered in potable waters. Since most of the important waterborne human pathogens are of fecal origin, tests for determining the presence of organisms normally found in human feces provide a means for alerting the microbiologist to any potential hazard from pathogens in the water. These tests for recovering normal fecal organisms, which occur in far greater quantities, need not be as sensitive and specific as methods which measure pathogens directly.

There is always room for improvement in the methods for ensuring the absence of pathogens from drinking water. However, we also intend to consider here microbiologically-based methods for the control of all phases of drinking water quality. Some of these methods are well established and routinely used in water testing while others are in



various experimental stages. Some may only be applied in special cases.

Probably no indicator system will be found ideal for all of the possible applications. Some may seem most appropriate for daily quality control; others may be most useful in measuring gradual deterioration in water quality over the long term. Some of the rapid or automated methods may find widespread application in determining water quality during emergencies such as cross-connections or line breaks. Other automated methods may be better applied to on-line monitoring of water quality.

This section will discuss both the theoretical bases of indicator systems and improvements in testing technology in an effort to evaluate their present and future roles in ensuring the quality and safety of drinking water.

#### 1. Established Viable Indicator Systems

The indicator systems in this category are the classical microbiological parameters of water quality which have proved useful for indicating the presence or potential presence of pathogens originating from fecal sources. It is generally agreed that a good indicator of these types of pathogens should fulfill the following criteria:

- It should be present and occur in greater numbers than pathogens.
- Any potential it may have for growth in the aquatic environment should not surpass that of pathogens.
- It should yield characteristic and simple reactions enabling, as far as possible, the unambiguous identification of the group.

The indicators in this group are dealt with in terms of their ability to satisfy these criteria and the extent to which they will continue to be relied upon, in the coming years, as the primary microbiological indicator systems of water quality.

a. Colony count. The colony count (also referred to as standard plate count, total microbial count, viable count, water plate count, total bacterial count, aerobic mesophilic viable bacteria, etc.) measures the number of

aerobic and facultative anaerobic heterotrophic bacteria in 1 or 0.1 ml of water that form colonies on nutrient medium at a specified incubation time and temperature. Nutrient media used and time and temperature of incubation vary from country to country [See Section D.6]. Colonies formed with this method do not represent all bacteria in the sample since no single growth medium will accommodate the nutritional requirements of all bacteria. Also, strict anaerobes and slower growing bacteria are missed by this method. Clusters or chains of bacteria or bacteria adsorbed to small particles do not necessarily yield colonies that were developed from each bacterium contained in such groupings.

Plates are incubated at 35 to 37°C for 24 to 48 h, favoring bacteria adapted to the body temperature of warm-blooded animals, or at 20 to 22°C for 48 to 72 h, favoring saprophytic bacteria which may be capable of causing operational disturbances in water treatment and distribution. Organisms able to grow at 20°C are found in tap water in much higher numbers than organisms that grow at 35°C. This is partly because the adverse conditions inherent in any water environment, such as lack of nutrients and sub-optimal temperatures, would tend to select for bacteria of little or no public health significance [See Section B.3].

The vast majority of bacteria are of this latter category and take part in virtually all cycles of nature: in the self-purification processes that occur in surface water, in antagonistic reactions among different species, and in the mineralization of organic matter (e.g., ammonia to nitrite, to nitrate), to name a few [See Section A]. Although the genera of bacteria detected by the colony count method may not be pathogenic to healthy humans, many of these organisms can produce acute or chronic infections in special cases -- for example, during medical therapy [See Section B.1.a(ix)]. Bacteria other than coliforms also are important because they can hamper filtration efficiency at the treatment plant [See Sections E.4 to 5] and their presence in large numbers often signifies a deterioration in finished water quality brought on when, for example, changes in pressure in a distribution system cause a release of microorganisms from dead ends and other protected sections [See Section F.2].

(i) Media Used for the Colony Count. Various nutrient media used in the colony count differ mainly with respect to the solidifier -- gelatin, agar, or silica gel. All nutrient media have to be enriched with some form of peptone

and meat or yeast extract, the type and concentration of which influence the number of developing bacteria [See also Section D.6].

Agar media contain either yeast or meat extract and differ mainly in the quality of peptone used and in the presence, in some cases, of glucose. However, the incorporation of glucose entails an additional analysis and calls for a number of precautions during sterilization in order to avoid hydrolysis of the sugar. For this reason, the European standardization committees INSTA and CEC do not recommend glucose media for the colony count technique (Commission of the European Communities, 1977).

Gelatin, sometimes used in conjunction with gelose, contains meat extract with or without sodium chloride. The gelatin is a nutrient for gelatin-liquifying bacteria, and as such, will influence the colony count. Thus, gelatin not only provides a quantitative measure, but also distinguishes certain "nuisance" bacteria, such as green-fluorescent pseudomonads [See Section C.2.c] and other bacteria that liquify gelatin rapidly. Gelatin nutrient media should be incubated only at 20°C, since they will liquify again at higher temperatures. Gelatin combined with agar in nutrient media can be incubated at 37°C and enables differentiation between bacteria that liquify gelatin and those that do not. Selective counting of gelatin liquifiers is accomplished after determination of the colony count by placing 5 ml of ammonium sulfate solution on the nutrient medium and counting colonies that become surrounded by clear halos after a few minutes. Silica gel retains its gelling properties regardless of variations in quality, but is not commonly used, mostly from lack of familiarity and consequent difficulty in preparing.

Studies compared yeast extract with meat extract at 37 and 20°C and found a more rapid development at 37°C and higher bacterial numbers at 20°C using the yeast extract. Numbers were either the same or lower when glucose was added (Commission of the European Communities, 1977). In addition, results from pour plates using plate count agar (American Public Health Association, 1976) were in agreement with peptone yeast extract medium, proposed by the ISO (Commission of the European Communities, 1977).

(ii) Method for Determining Colony Counts. Very simply, the procedure entails mixing the sample, then transferring 1.0 or 0.1-ml volumes of diluted or undiluted sample

into culture plates, and adding 10 ml of melted nutrient medium. The covered plates are swirled in a motion describing a figure 8, are allowed to solidify (within 10 min) on a level surface, and are then incubated. Colony counts are recorded from plates containing 30 to 300 colonies, and counts are made using a Quebec counter or a counter that gives equivalent magnification and illumination. Densely grown colonies may be counted by taking an average of the colony numbers within 1 cm<sup>2</sup> at six different sites on the dish, provided the colonies are evenly distributed.

The colony number is calculated by using the formula:

$$ab/c = G$$

where a = number of colonies counted per cm<sup>2</sup>; b = area of the culture dish in cm<sup>2</sup>; c = volume of the water sample transferred into the dish, in ml; and G = number of colonies per ml of the water sample. The colony count is expressed as a number per 1 ml of sample water, to not more than two significant digits. The colony number should be recorded along with information on type of culture medium and incubation time and temperature applied. Numbers of gelatin liquifiers, if determined, also are reported [See Section C.4.h].

(iii) Applications of the Colony Count. The colony count is not, by itself, an indicator of fecal pollution [See Sections C.1.b to d]. However, when used routinely to monitor water supplies -- at least every three months -- it can provide baseline data on the general bacterial population and aid in assessing the degree of bacterial pollution of that supply. It is an especially valuable tool, when used in conjunction with other tests, for assessing the purity of a possible new raw water source.

Used as part of routine analyses, the colony count would reveal any changes in the bacteriological quality of finished water in storage reservoirs and distribution systems. Colony counts taken repeatedly at specific sites in a water treatment plant, at different times of the year, and at various points throughout the distribution system offer a valid procedure for maintaining ongoing quality control [See also Section C.4]. Application of this method would indirectly limit the occurrence and level of Pseudomonas, Flavobacterium, and other secondary pathogenic invaders that could be harmful in a hospital environment [See Section B.1.a(ix)]. It would, in addition, serve to monitor the

effectiveness of chlorine throughout the distribution network. Also, it would alert water authorities to any deterioration in filtration efficiency at the treatment plant or sediment accumulation in the distribution network with consequent build-up of bacteria.

Many filter media (e.g., charcoal, polysterol, and asbestos) and ion exchange resins used in the home and elsewhere have been known to support large increases in bacterial populations (Muller and Herzel, 1973) [See Section G.2]. The colony count method is well suited as an indicator of such disturbances.

A sudden increase in the colony count from a given source can serve as an early indication of contamination. Indeed, sudden increases in colony counts which had been low for several years have, in the past, indicated the sources of waterborne outbreaks in the FRG. Such an increase in the colony count occurred prior to the typhoid fever outbreak in Hannover in 1926 (Mohrmann, 1927), the cause of which was flooding of untreated well water with heavily contaminated river water. High colony counts were observed in distribution system water before it was found to be positive for E. coli and total coliforms. Some 40,000 people became ill with nonspecific gastroenteritis ("water disease") [See Section B.1.d] two weeks before the first cases of typhoid fever were reported. The same observations were made during the typhoid fever outbreaks at Pforzheim in 1919 and at Gelsenkirchen in 1889.

Large populations ( $\approx 1,000$  per ml) of noncoliform genera, including Pseudomonas, Bacillus, Streptomyces, Micrococcus, Flavobacterium, Proteus, and various yeasts can suppress the growth of coliform bacteria below detectable levels. This may well have been the reason that coliform readings were negative just prior to a salmonellosis outbreak involving 16,000 cases in Riverside, California (U.S.) [See Section B.1.a(i)]. The colony count, used in conjunction with coliform tests, would reveal such interferences by noncoliform bacteria and thereby afford a more accurate interpretation of results.

(iv) Recommended and Mandatory Maximum Limits. Opinion varies in different countries as to the necessity or value of incorporating total microbial counts into routine water quality surveillance programs [See Section D.6]. Even in places where these tests are routinely performed, water

quality criteria will differ with respect to maximum allowable concentrations, evaluation of the counts, and the kind of water that shall be characterized by the count (Müller, 1977b) [See Table C.1.a-1]. Except for bottled water (which has legal limits imposed of 1,000 colonies per ml) [See Section G.6], all other types of drinking water in the FRG are subject only to recommended guidelines; however, German drinking water law specifies the method by which the colony count is to be conducted (Aurand, et al., 1976).

The colony count is not a required test in the U.S., but many health departments, water supply agencies, and local jurisdictions observe limits commonly applied within a range of 100 to 500 colony-forming units per ml. Geldreich (reviewed in Safe Drinking Water Committee, 1977) proposed that a 500 per ml limit (at 35°C for 48 h) be placed on the colony count and that immediate investigations of water treatment and distribution systems be undertaken whenever this limit was exceeded. The U.S. government has acknowledged the importance of the colony count in recommendations of the National Academy of Sciences, entered into the Federal Register (Environmental Protection Agency, 1977): "It [the colony count] is, however, a valuable procedure for assessing the bacterial quality of drinking water.... The SPC [colony count] has major health significance for surface-water systems that do not use sedimentation-flocculation-filtration, and chlorination, and for those systems and [sic] do not include chlorination."

(v) Summary. The colony count is not a substitute for total coliform measurements of the sanitary quality of potable water. However, if it is used in conjunction with other tests, bacterial numbers and types determined by this method can provide an integrated picture of conditions upon which to base decisions for further microbiological testing, epidemiological surveys, and repair or upgrading of treatment plants and distribution systems.

b. Total Coliforms. The relationship between the ingestion of polluted water and the occurrence of certain diseases has been recognized since the beginning of recorded history. Even before specific agents had been detected, epidemiologists were able to show that some human activities could give rise to disease. Von Fritsch's observation in 1882, that the presence of Klebsiella pneumoniae and K. rhinoscleromatis signified fecal contamination, and Escherich's

TABLE C.1.a-1

COLONY COUNT CRITERIA FOR VARIOUS TYPES OF WATER  
IN SEVERAL EUROPEAN COUNTRIES

Country	Maximum Allowable Numbers/ml	Incubation Temperature	Type of Water
Poland	25	--	--
Czechoslovakia	20	37°C	Public supply
	100	20°C	Public supply
	100	37°C	Well water
	500	20°C	Well water
Yugoslavia	10	37°C	Treated water
	100	37°C	Raw groundwater
	300	37°C	Raw surface water
Romania	20	--	Public water supply for 70,000 customers
	100 to 300	--	Other supplies
Switzerland	100	--	Raw water entering works
	300	--	Raw water during distribution
	20	--	Treated water immediately after treatment
	300	--	Treated water in the distribution system

TABLE C.1.a-1 -- Continued

Country	Maximum Allowable Numbers/ml	Incubation Temperature	Type of Water
Spain	50 to 65	37°C	Good quality finished water
	100	37°C	Tolerable quality finished water
Netherlands, Sweden, GDR	100	20°C	--
Fed. Republic of Germany	20 (recommended)	20 $\pm$ 2°C	Disinfected water
	100 (recommended)	20 $\pm$ 2°C	All other kinds of drinking water
	1,000 (recommended)	20 $\pm$ 2°C	Water tanks
	1,000 (mandatory)	20 $\pm$ 2°C	Bottled water
France, Austria, UK, Greece, Israel, Italy, Netherlands, US	--	--	No recommended or mandatory values



isolation of Bacillus coli (Escherichia coli) from feces in 1885, mark the beginning of the science of sanitary water bacteriology.

During the next twenty years, investigators were quick to recognize the difficulties in isolating pathogens compared to the relative ease in isolating B. coli from polluted waters (Heathman, et al., 1936). Before the turn of the century, Theobald Smith had observed that the presence of B. coli in water must be due to fecal discharges. Survival studies indicated that B. coli persisted longer in water than did the typhoid bacillus, the most feared pathogen of the day (Heathman, et al., 1936) [See also Sections B.1.a(i), B.3, and E.1]. Thus, the rationale for the use of B. coli as an indicator of the sanitary quality of water was established, being based on: its regular association with feces; its presence in water in numbers greater than those of pathogens; and its superior survival capabilities. In 1905, when the first edition of Standard Methods of Water Analysis was issued by the American Public Health Association, B. coli was recommended for use as an indicator of the bacteriological condition of water supplies.

There are several operational definitions of the coliform group. These differ in a number of procedural details [See Sections D.2 to 3]; but all tend to result in the inclusion of organisms from the genera Escherichia, Klebsiella, Enterobacter, and Citrobacter, not all of which are of fecal origin. For example, in North America, the 14th edition of Standard Methods for the Examination of Water and Wastewater (American Public Health Association, 1976) defines the total coliform group as: all aerobic and facultative anaerobic, gram-negative, nonsporeforming, rod-shaped bacteria that ferment lactose with gas formation within 48 h at 35°C; or, all organisms that produce a colony with a golden-green metallic sheen within 24 h on an Endo-type medium containing lactose. Members of the coliform group also are motile by peritrichous flagellation or immotile, they reduce nitrate ions to nitrite ions under anaerobic conditions, and they are oxidase-negative, a feature which distinguishes them from Aeromonas. These definitions are not to be regarded as identical but rather, as indicative of organisms roughly equivalent in sanitary significance.

The total coliform group is used today in many countries to indicate the microbial quality of raw and finished drinking water [See Sections D.2 to 3], and apparently this indicator system continues to ensure, with very few exceptions, that drinking water shall be safe for human consumption.

(i) Isolation Methods. Two standard methods are available for coliform determinations: the multiple tube fermentation procedure and the membrane filter technique. In the multiple tube fermentation procedure, tenfold dilutions of the water to be tested are inoculated into tubes containing the appropriate medium (five tubes per dilution). Dilution is unnecessary, however, for drinking water examination because of the expected low bacterial counts, so it is possible to set up 1 x 50 ml and 5 x 10 ml samples. The presence of gas (and acid) after incubation for 48 h at 35 or 37°C constitutes a positive presumptive test for coliforms and must be followed by confirmatory procedures. Results are reported as a most probable number (MPN). The MPN is a statistical estimate of the number of bacteria that, more probably than any other number, would give the observed result; it is not an actual count of the bacteria [See Section D.3].

The membrane filter (MF) technique has, in recent years, largely replaced the multiple tube fermentation procedure for the routine examination of drinking water. However, the multiple tube fermentation method is still of value when conditions render the membrane filter technique unusable (e.g., for water that is very turbid or heavily populated with noncoliform organisms capable of growth on the medium), and as a reference standard procedure.

The MF technique became accepted in bacteriological water analysis when it was demonstrated to be capable of producing results equivalent to those obtained by the multiple tube fermentation procedure. With the MF technique, the water sample is passed through a filter of 0.45  $\mu$ m pore diameter; the filter is placed on an appropriate selective/differential medium and incubated for 24 h, after which time the coliform colonies are counted. The technique allows for large quantities of non-turbid water to be examined, thus increasing sensitivity and reliability while markedly reducing time, labor, equipment, space, and material needed [See Section D.2]. A current area of controversy with the MF technique concerns the variable performance of filters in the recovery of coliforms. Brown (1973) reported that numbers of E. coli were 15 to 18 percent less on filters than on standard plate cultures. He attributed the discrepancy to lack of nutrients. Variation also has been ascribed to differences in filter sterilization procedures, surface pore size, and the source of coliforms (Sladek, et al., 1975; Tobin and Dutka, 1977).

(ii) Evaluation as an Indicator. There are several serious problems with the general use of total coliforms as indicator organisms (except when testing finished drinking water). Total coliforms can grow in water of rather low organic matter content as well as in low temperature water such as cold mountain streams. They have been recovered in soil, on vegetation, in forest and farm products, and in many other environments (Geldreich, et al., 1964) including those almost untouched by humans. Although these organisms clearly are not specific for fecal pollution, they are considered by some to be preferable to thermo-tolerant coliforms [See Section C.1.c] as quality indicators for finished water because of their greater resistance to disinfection. Lin (1977) and others have shown that the total coliform group is more abundant and relatively more resistant to chlorine and other stresses than are thermo-tolerant coliforms, and thus it serves as a more stringent measure of water quality. If total coliforms are detected in finished water their presence should not be ignored, but should signal an investigation of the type and source of pollution. There have been a few documented cases in which pathogenic organisms were isolated from water that was negative for coliforms (Dutka, 1973). This may have been due to inhibition of the coliforms by other microorganisms, a phenomenon known to occur when colony counts at 35°C exceed 500 per ml (Geldreich, et al., 1972) [See Section C.1.a].

(iii) Conclusion. The total coliform group was one of the first indicator systems used and is still used in many surveys. It has limited value as a direct indicator of fecal pollution in raw source waters because of the ability of some coliforms to multiply readily in the environment and because of the methodological difficulties involved. Hence, it is more appropriate to monitor raw water for the presence of E. coli or thermo-tolerant coliforms [See Section C.1.c], and to test finished water for the presence of total coliforms which serve as a sensitive indicator of disinfection inadequacy or problems during distribution. It is used in many countries as the primary microbiological test for evaluating the quality of finished water and may continue to be for some time to come, or at least until easier, faster, and more sensitive indicator systems are well established [See Sections C.2 to 4].

(iv) Summary. The total coliform measurement is one of the oldest and most frequently used methods in sanitary microbiology. It enumerates bacteria of the genera Escherichia, Klebsiella, Enterobacter, and Citrobacter. Since some of these bacteria are not restricted to fecal origin, their presence should not be construed as a specific indication of contamination with fecal or pathogenic organisms, but rather, as a cause for further investigation. On the other hand, the total coliform group is more resistant to chlorination and environmental stresses than many other indicators, and so continues to be preferred by many water authorities as the primary indicator system for evaluating the microbiological quality of finished water.

c. Thermo-Tolerant Coliforms and Escherichia Coli. For many years, the total coliform group [See Section C.1.b] served as the main indicator of water pollution. However, because many of the organisms in this group are not limited to fecal sources, methods were developed to restrict the enumeration to those coliforms which are more clearly of fecal origin. A modified method devised by Eijkman (1904) called for a higher incubation temperature and this was refined further to distinguish what are known as thermo-tolerant coliforms (also referred to as fecal coliforms; it was the consensus of this working group that the descriptor "thermo-tolerant" is more accurate and more representative of the thinking of scientists in the participating countries) (Hajna and Perry, 1943; Geldreich, et al., 1958). This indicator group has all the properties of the total coliform group and, in addition, is able to ferment lactose with the production of gas in 24 h at 44.5°C (American Public Health Assoc., 1976). In general, this test enumerates organisms of the genera Escherichia and Klebsiella. Klebsiella [See Section C.2.d] may derive from nutrient-rich, non-fecal sources; a further procedural refinement permits testing specifically for E. coli.

E. coli is the only member of the coliform group that unquestionably is an inhabitant of the intestinal tract; hence, it has come to be the definitive organism for demonstrating fecal pollution of water. E. coli has the definitive properties of all members of the coliform group [See Section C.1.b], but possesses the following additional

characteristics: production of acid and gas from lactose at 44°C, glutamic acid-decarboxylase activity [See also Section C.4.e], no pigmentation on nutrient agar during an incubation of eight days (20°C), inability to utilize citrate as a sole carbon source, negative cyanide test, no urea or gelatin decomposition, positive methyl red reaction, and negative Voges-Proskauer reaction. Most of the strains form indole from tryptophan contained in tryptone broth and produce acid and gas from glucose at 44°C. It must be understood that not all these tests are carried out for routine water analyses, so the bacteria enumerated could perhaps be best described as "presumptive E. coli".

E. coli meets the criteria of a valid fecal indicator in that: it is present in the intestine in numbers larger than those of enteric pathogens; it behaves similarly to enteric pathogens within the aquatic environment; and it is less susceptible than most enteric pathogens to treatment or disinfection procedures. The presence of E. coli in a water supply indicates contamination with fecal material from warm-blooded animals such as birds and humans. One must assume that, if E. coli has gained access to a waterway, enteric pathogens also may have entered this water. Indeed, results from recent epidemiological studies (Cabelli, et al., 1976) show a higher statistical relationship between presence of E. coli and incidence of gastrointestinal illness than other members of the Klebsiella-Enterobacter-Citrobacter group.

(i) Methods for Enumerating Thermo-Tolerant Coliforms and E. Coli. Since it is impossible in water investigation to test all characteristics essential for identifying species, simplified procedures have been developed. These must be followed precisely, for any deviation from the prescribed procedure (e.g., use of a different nutrient medium) may invalidate the results.

Methods used in various countries for enumerating thermo-tolerant coliforms are essentially high temperature modifications of the total coliform tests. As with the total coliform test, there are two methods for enumerating thermo-tolerant coliforms -- the membrane filter technique [See Section D.4] and the multiple tube fermentation procedure [See Section D.5] -- upon which are based two separate (but hygienically equivalent) definitions. The IMViC tests

(indole, methyl red, Voges-Proskauer, and sodium citrate) are often used to differentiate between coliform isolates, particularly to determine the presence of E. coli (American Public Health Assoc., 1976). In the FRG, as in several other countries [See Sections D.4 to 5], there are very specific protocols for identifying E. coli (Müller, 1977b). Here, E. coli is differentiated from coliform bacteria by means of tryptone broth cultures according to the following procedure.

A single colony of a pure culture is inoculated into tryptone broth; after the culture becomes slightly turbid (4 to 7 h), it is inoculated into the following nutrient media: ammonium-citrate agar slant (the material should be distributed homogeneously on the agar slope), glucose broth, lactose broth, nutrient agar plate, and Endo agar plate. All nutrient media, including tryptone broth, are then incubated for  $20 \pm 4$  h -- glucose broth at  $44 \pm 0.5^\circ\text{C}$  in a water bath, the other nutrient media at  $37 \pm 1.0^\circ\text{C}$  in an air incubator. After incubation, the Endo and nutrient agar plates are examined to determine whether all colonies show the same morphology. If not, fresh Endo agar plates must be inoculated from well isolated single colonies picked from the nutrient agar plate, and then incubated.

If a pure culture is present on the nutrient agar plate, the cytochrome oxidase test is performed by putting two to three drops of dimethyl-p-phenylenediamine on the colonies. The reaction is considered positive if the colonies turn blue within 1 to 2 min; if there is no color change, the reaction is negative. A positive cytochrome oxidase reaction means that colonies are not coliform bacteria (they may well be Aeromonas [See Section C.2.h] or Pseudomonas [See Section C.2.c], and no further testing is required. A negative cytochrome oxidase reaction and a positive reaction in lactose broth (i.e., gas and acid production) confirms the presence of coliform bacteria in the water sample. If acid is detected (brom cresol purple indicator turns from purple to yellow) without gas being present, the lactose broth is incubated another 24 h (48 h total elapsed time) and checked for gas, the presence of which is considered a positive result. If the result of the lactose broth culture is negative, there are no coliform bacteria present and no further tests are indicated. When coliforms are found to be present, the following biochemical

reactions are performed to determine the presence of E. coli:

1. Glucose Broth. If gas and acid are detected after incubation at  $44 \pm 0.5^{\circ}\text{C}$  (indicator changes from purple to yellow), the reaction is considered positive; no gas production, whether or not acid is present, indicates a negative result.
2. Tryptone Broth. Several drops of indole reagent are added to the incubated broth and the tube is agitated gently. The reaction is considered positive if a red surface layer forms in the culture within 1 to 2 min. If the surface layer remains yellow, the reaction is negative.
3. Ammonium Citrate Agar Slant. If visible colonies appear on the culture medium or if the indicator has changed from green to blue (even without detectable growth), the reaction is positive. Otherwise it is considered negative.

E. coli is confirmed to be present in the water under investigation by positive results in glucose broth (gas production) and in tryptone broth (indole positive), and by negative results on ammonium citrate agar.

(ii) Evaluation of Thermo-Tolerant Coliforms and E. Coli as Indicators. Recent research has confirmed the validity of the thermo-tolerant coliform test as an indicator of the potential presence of enteric pathogens in water. It has been shown that the frequency of Salmonella detection in water is related to the density of thermo-tolerant coliforms (Geldreich, 1970; Van Donsel and Geldreich, 1971). At thermo-tolerant coliform densities of 1 to 200 per 100 ml, Salmonella was detected in 28 percent of water samples examined; this frequency rose 85 to 98 percent in waters with thermo-tolerant coliform counts above 2,000 per 100 ml. Studies on survival in river water (Mitchell and Starzyk, 1975), well water (McFeters, et al., 1974), and septic tank effluent (Calabra, 1972) have shown that thermo-tolerant coliforms persist longer than salmonellae [See Sections B.3 and E.1]. Because they are more specific for fecal contamination, thermo-tolerant coliforms and E. coli are preferred over total coliforms for monitoring raw water for the potential presence of pathogens [See also Section C.1.b]. E. coli also is preferred in several European

countries for use in monitoring finished drinking water [See Section D].

(iii) Conclusion. Thermo-tolerant coliforms and E. coli are valuable indicators of fecal pollution in many situations where total coliforms are less applicable because of their widespread occurrence in the environment. When the means are available, E. coli is a preferred indicator for raw water because it excludes most of the Klebsiella organisms [See Section C.2.d] which may or may not originate from fecal sources. Because of its unrivaled specificity for fecal pollution, E. coli also is used for routine monitoring of finished drinking water, even though it is somewhat less resistant than total coliforms to chlorine and other disinfectants.

(iv) Summary. Coliform organisms can be further subdivided into thermo-tolerant coliforms (those capable of growth at 44°C) or E. coli, one of the principal species making up the thermo-tolerant coliform group. These latter two indicators are considered more specific for fecal pollution than total coliforms and are preferred for monitoring raw water quality. They also are the primary indicators used for finished water in several countries.

d. Fecal Streptococci. The three most commonly employed indicator groups for establishing the presence of sewage in a water supply, are total coliforms, thermo-tolerant coliforms, and fecal streptococci. All three groups occur in feces and feces-polluted waters in greater numbers than pathogens and fit all the other criteria for a valid indicator system [See Section C.1.Intro.]. However, drawbacks to total coliforms as indicators in raw water have been noted, due to their presence in the environment remote from any fecal pollution, and growth in nutrient-enriched waters [See Section C.1.b] (Clausen, 1977; Geldreich, 1970). Thermo-tolerant coliforms, a more restricted subgroup of the total coliform group, occur only in association with feces and thus are a better indicator of raw water quality. However, thermo-tolerant coliforms are more sensitive to conditions outside the animal intestinal tract than total coliforms, and possibly some pathogens including viruses, and thus may be subject to excessive die-off [See Section C.1.c].



Fecal streptococci serve as an index of fecal pollution of raw water and may provide valuable supplementary data when used in conjunction with thermo-tolerant coliforms. A ratio of thermo-tolerant coliforms to fecal streptococci can be used to identify the source of pollution as being either human- or nonhuman-derived. This is possible because humans have greater numbers of thermo-tolerant coliforms than fecal streptococci in their feces, whereas the reverse is true of other warm-blooded animals. In addition, the fecal streptococci are more resistant than coliforms to disinfection, are capable of longer survival in the environment, and do not exhibit aftergrowth, as is true of the coliforms. The fecal streptococci should therefore be considered a valuable indicator group for raw water quality when used as an adjunct to thermo-tolerant coliforms.

Fecal streptococci originate in the intestinal tracts of warm-blooded animals and are discharged with feces. They are easily detected in water because of characteristics which readily separate the fecal streptococci from other groups of bacteria including other gram-positive cocci. The fecal streptococci belong to the family Streptococcaceae and include catalase-negative, non-motile, gram-positive cocci that are indifferent to oxygen (Buchanan and Gibbons, 1974). The term fecal streptococcus in this discussion, as well as in most of the literature, is used as a synonym for Lancefield's group D streptococcus, but these terms are not precisely equivalent. Streptococci (e.g., S. mitis and S. salivarius and the group Q streptococci of fowl) other than those possessing the group D polysaccharide antigen between their cytoplasmic membrane and cell wall may occur in feces and thus may also be termed fecal streptococci (Clausen, et al., 1977); however these are not the streptococci that originate in the intestinal tracts of most warm-blooded animals. The group D streptococci (or fecal streptococci of sanitary significance; American Public Health Association, 1976) include:

Group D Streptococci

Streptococcus faecalis  
Streptococcus faecalis variety liquefaciens  
Streptococcus faecalis variety zymogenes

Streptococcus faecium  
Streptococcus faecium variety durans  
Streptococcus faecium variety casseliflavus

Streptococcus bovis

Streptococcus equinus

The first two species and their varieties are termed the "enterococci" and are the fecal streptococci that may be of human origin. In addition to these two species, feces of nonhuman warm-blooded animals also contain varying concentrations of S. bovis and S. equinus (Geldreich and Kenner, 1969) [See Table C.1.d-1]. The latter two species have been associated with pollution involving meat processing plants, dairy wastes, cattle feedlots, duck farms, and runoff from livestock pasture land (American Public Health Association, 1976; Geldreich, 1970); the detection of either of them indicates that the source of pollution is from animals other than humans.

(i) Isolation Methods. As is true for coliform testing, determinations of fecal streptococcus densities in water may be done by the multiple tube fermentation procedure or the membrane filter procedure. The mechanics and comparisons of these two general procedures are described elsewhere [See Section C.1.b]. In addition, fecal streptococci may be detected by a pour plate procedure (American Public Health Association, 1976).

The most probable number (MPN) method for determining fecal streptococcus concentrations, like the procedures for total or thermo-tolerant coliforms, includes both a presumptive and confirmed step (American Public Health Association, 1976). In the U.S., the presumptive medium used is azide dextrose (AD) broth. Replicate sets of three or five tubes of the medium are inoculated with tenfold dilutions of the water sample and incubated at 35°C. Growth constitutes a positive test after either 24 or 48 h of incubation. All tubes demonstrating turbidity are transferred to ethyl violet azide (EVA) broth. Growth in EVA, after 24 to 48 h of incubation at 35°C, is confirmed evidence of the presence of fecal streptococci. The MPN is taken from the number of positive EVA tubes.

Although the media in the U.S. for the multiple tube procedure have been adopted as part of their standard method (American Public Health Association, 1976), other media may be substituted for AD and/or EVA. Kibbey and coworkers (1978) have achieved higher fecal streptococcus recoveries when substituting KF streptococcus (KFS) agar (Geldreich and Kenner, 1969) or m-Enterococcus (ME) agar for EVA in the confirmed procedure, following incubation in either AD, KFS broth, or ME broth. The combination of KFS or ME presumptive broths followed by KFS or ME agar as the confirmed media

TABLE C.1.d-1

THERMO-TOLERANT COLIFORM (TTC)/FECAL STREPTOCOCCUS (FS) RATIOS AND  
FS DISTRIBUTIONS IN WARM-BLOODED ANIMALS

Fecal Source	Ratio TTC/FS	Occurrence (%)			
		Enterococci	<u>S. Bovis</u> <u>S. Equinus</u>	Atypical <u>S. Faecalis</u>	<u>S. Faecalis</u> Variety <u>Liquefaciens</u>
Human	4.4	73.8	None	None	26.2
Animal pets					
Cat	0.3	89.9	1.5	2.2	6.3
Dog	0.02	44.1	32.0	14.4	9.6
Rodents	0.04	47.3	17.1	0.4	35.3
Livestock					
Cow	0.2	29.7	66.2	None	4.1
Pig	0.04	78.7	18.9	None	2.4
Sheep	0.4	38.9	42.1	None	19.0
Poultry					
Duck	0.6	51.2	48.8	None	None
Chicken	0.4	77.1	1.1	None	21.8
Turkey	0.1	76.7	1.6	None	21.8

From Geldreich and Kenner, 1969.

have yielded the greatest number of streptococcal isolates (Kibbey, et al., 1978). The use of ME medium, however, has been discouraged by the American Public Health Association (1976) due to its poor recoveries of S. bovis and S. equinus; whereas these two species may be recovered on KFS medium (Clausen, et al., 1978).

The use of membrane filtration (MF) or agar pour plates for fecal streptococcus detection is recommended over the MPN procedure because recoveries on the MF and pour plate media are higher and less affected by interfering organisms, and greater numbers of false positive reactions occur in the AD/EVA broth MPN system (American Public Health Association, 1976). Also the MPN method using AD/EVA broths detects only the enterococci (Clausen, et al., 1978). For the MF procedure, filters are incubated on KFS agar at 35°C for 48 h, at which time all dark red to pink colonies (due to the reduction of the tetrazolium salt indicator) are counted (American Public Health Association, 1976). Turbid waters or chlorinated effluents cannot be analyzed by the MF procedure and one of the other methods must be employed.

An alternative method to either the MPN or MF method for fecal streptococcus detection is a pour plate procedure (American Public Health Association, 1976). The procedure should be used preferentially over the MF technique for those samples containing few fecal streptococci associated with significant turbidity. The only disadvantage to this procedure is that the sample volume that may be tested is usually limited to 1 ml. Two media have been recommended for use in the U.S.: KFS agar and Pfizer selective enterococcus (PSE) agar. Surface and subsurface colonies produced by fecal streptococci after 48 h of incubation at 35°C are dark red to pink. Few nonfecal streptococcus colonies will be observed on KFS agar because of the selectivity of the medium (American Public Health Association, 1976). Stream samples may sometimes contain gram-positive soil organisms that may grow on this medium, such as Corynebacterium or Bacillus species (American Public Health Association, 1976). Other false positive organisms reported to grow on this medium include: Pediococcus, Lactobacillus, and Staphylococcus (Clausen, et al., 1977); but none of these organisms reduce tetrazolium and thus, will not form a red colony. Fecal streptococci on PSE agar produce brownish-black colonies with brown halos, due to the formation of iron salts of hydrolyzed esculin, after 24 h of incubation at 35°C. The only gram-positive cocci that will grow and exhibit esculin hydrolysis are the group D streptococci. Listeria monocytogenes,

the only other organism capable of both growth and esculin hydrolysis on PSE agar, shows only pinpoint colonies at 24 h, and coloration of the colonies is less marked with Listeria than with the fecal streptococci (American Public Health Association, 1976). The advantage of PSE agar over KFS agar is the shorter incubation time of 24 h for PSE agar as compared to 48 h for KFS agar. Unfortunately PSE agar does not lend itself to use with the MF technique unless a PSE agar overlay is added after the MF has been applied to the medium. The overlay allows visualization of esculin hydrolysis directly above the colonies without having to turn over the plate to see the blackening of the medium under the MF (Clausen, et al., 1977).

All the media used for the detection of fecal streptococci are dependent on the inclusion of the metabolic inhibitor, sodium azide, which poisons hemeporphyrin components (e.g., the enzyme catalase and the cytochromes of the respiratory chain) of cells. Because the fecal streptococci lack any porphyrin-containing enzymes or coenzymes, they survive in the presence of this poison, whereas any aerobic or facultative anaerobic organisms should be completely inhibited.

Although the detection of fecal streptococci is relatively straightforward, and the selective media which are recommended yield few false positives, their speciation is extremely tedious and several different taxonomic schemes have been proposed (American Public Health Association, 1976; Buchanan and Gibbons, 1974; Geldreich and Kenner, 1969; Kibbey, et al., 1978) which have led to considerable confusion. The results of any identification are determined by the taxonomic scheme which is employed (Kibbey, et al., 1978). Characteristics of the enterococci used in most identification schemes include: growth at 10 and 45°C, growth at pH 9.6, tolerance to 60°C for 30 min, tolerance to 6.5 percent NaCl, growth in 40 percent bile broth, and reduction of 0.1 percent methylene blue. To identify the varieties of enterococci and to separate out S. bovis and S. equinus, other biochemical tests must be employed.

(ii) Evaluation as an Indicator of Raw Water Quality. The fecal streptococci are a diverse group of organisms that have variable fecal origins and survival characteristics; they include several biotypes of limited sanitary significance (Geldreich, 1970; Geldreich, 1979). Usually the detection of fecal streptococci in water denotes fecal pollution; but if they were to be used as the sole indicator

system, the existence of strains that have an environmental origin should be noted. S. faecium variety casseliflavus is described by Mundt and Graham (1968) as being plant-derived and possessing a yellow pigment (unlike other streptococci). It occurs in high numbers on vegetation, but rarely in association with fecal material (Mundt and Graham, 1968), although it also has been reported to be of human origin (Ator and Starzyk, 1976). It appears to be a transitional organism that has properties of both S. faecalis and S. faecium (Ator and Starzyk, 1976). S. faecalis variety liquefaciens also occurs in the environment in association with plants, insects, and certain types of soil, in addition to occurring in animal feces in high proportions (American Public Health Association, 1976 ; Clausen, et al., 1977; Geldreich, 1970). Geldreich (1970) has found high numbers of this organism in unpolluted wells, perhaps due to contamination of the wells by soil or insects. An atypical biotype of S. faecalis capable of starch hydrolysis may be isolated in association with vegetation, but rarely from feces. Recovery of the starch-hydrolyzing strain is uncommon from water, soil, insects, or warm-blooded animals. Group D isolates of human origin, by contrast, were found not to hydrolyze starch (Clausen, et al., 1977).

The plant-associated streptococci of nonfecal origin closely resemble the streptococci of fecal origin (Kibbey, et al., 1978), and low numbers of certain biotypes (e.g., S. faecalis variety liquefaciens) are present even in good quality waters free of fecal pollution (Geldreich, 1970); although in waters from vegetable-processing plants their numbers may be increased. Therefore, if high numbers of fecal streptococci are detected in the absence of thermo-tolerant coliforms, misinterpretation may be avoided if the species of the fecal streptococci are determined, so as to learn whether environmental rather than enteric varieties are involved.

Fecal streptococcus densities may be best used in association with thermo-tolerant coliforms as a ratio used to assign the probable source of waste discharge as being either human or from farm animals and wildlife. Fecal streptococcus densities are significantly higher than thermo-tolerant coliform densities in all warm-blooded animal feces except for those of humans as shown in Table C.1.d-1 (Geldreich and Kenner, 1969). In human feces, the thermo-tolerant coliform to fecal streptococcus ratio is always greater than four, whereas ratios for all other warm-blooded animal feces

are always less than 0.7. However, this ratio is influenced by die-off and is only valid at the waste outfall or during the first 24 h after discharge into the receiving waters (Geldreich and Kenner, 1969). Due to environmental factors such as death, survival, or aftergrowth, the proportions of fecal streptococci and thermo-tolerant coliforms in water may be altered (Geldreich, 1979).

Table C.1.d-1 illustrates the distribution of the fecal streptococci in warm-blooded animals including man. S. bovis and S. equinus do not occur in the feces of humans and therefore are considered specific indicators of nonhuman animal pollution; however, S. bovis and S. equinus are the indicator organisms most sensitive to rapid die-off outside the animal intestinal tract (Geldreich, 1970; Geldreich, 1978; Geldreich and Kenner, 1969). After 24 h at either 10 or 20°C water temperatures, less than 10 percent of S. bovis can be recovered, and even shorter survival times are seen with S. equinus (Geldreich and Kenner, 1969).

Although limited survival of S. bovis and S. equinus occurs when outside the intestinal tract, survival of the other fecal streptococci in the environment is greater. During favorable temperatures and in waters with high electrolyte contents, survival of fecal streptococci is enhanced (Geldreich, 1970; Geldreich, 1978). S. faecalis and S. faecalis variety liquefaciens persist longer in water than either thermo-tolerant coliforms or Enterobacter aerogenes (Clausen, et al., 1977). Unlike the total or thermo-tolerant coliforms, the fecal streptococci rarely multiply in polluted water, with the exception of the naturally-occurring S. faecalis biotypes that may replicate in vegetable processing wastewaters (Clausen, et al., 1977; Geldreich, 1978). Fecal streptococci are also more resistant to chlorine, and populations surviving disinfection are not as subject to aftergrowth as are total and thermo-tolerant coliforms. The apparent resistance of fecal streptococci to disinfectants and adverse environmental conditions is probably due to the clustering of the organism in chains: in a reaction with a disinfectant, all cells of a chain or cluster must be destroyed, or the surviving cells will again manifest growth of the chain or cluster (Berg, 1978). With the extended survival of the fecal streptococci beyond that of total or thermo-tolerant coliforms, and because they are heavily clumped, they more closely parallel survival of the enteric viruses (Berg and Metcalf, 1978; Clausen, et al., 1977; Kenner, 1978). Similar rates of destruction for both fecal streptococci and enteric viruses have been observed in mesophilic digested sludge, raw fresh waters, and possibly may occur in ocean waters (Berg and Metcalf, 1978; Kenner, 1978).

(iii) Conclusions. Like the total and thermo-tolerant coliforms, the fecal streptococci may be used as fecal pollution indicators in water because all three of these groups are present in the feces of humans and warm-blooded animals in higher concentrations than pathogens and also are present in feces-contaminated waters. In raw water, fecal streptococci are less numerous than total coliforms, which are ubiquitous in nature and do not necessarily indicate fecal contamination. Although the fecal streptococci occur in low numbers within environmental sources not necessarily associated with feces, their presence in high numbers, especially if thermo-tolerant coliforms also are present, indicate fecal additions have occurred. Because of the environmentally-associated biotypes, S. faecalis variety liquefaciens, the atypical S. faecalis, and S. faecium variety casseliflavus, it is important to include thermo-tolerant coliform densities with fecal streptococcus densities to determine whether fecal pollution actually has occurred, and to define the polluting source by the thermo-tolerant coliform to fecal streptococcus ratio.

Because fecal streptococci are not often found associated with plants in pristine environments, it appears that plant populations of fecal streptococci originate from a fecal source and establish a reservoir which then may be spread to other vegetation (Clausen, et al., 1977). To compensate for the low levels of the naturally occurring biotypes, fecal streptococcus densities of less than 100 per 100 ml should be considered of little sanitary significance (Geldreich, 1970; Geldreich, 1978).

Unlike the total coliforms, the fecal streptococci rarely multiply in polluted waters, but survive in waters, especially those containing levels of high electrolyte, at favorable temperatures (Geldreich, 1970; Geldreich, 1978). Although the two species occurring in the feces of nonhuman warm-blooded animals (i.e., S. bovis and S. equinus) survive for only short periods in the environment, the other fecal streptococci (i.e., the enterococci) have much greater survival capabilities outside the animal host than either S. bovis or S. equinus and also as compared to either total or thermo-tolerant coliforms.

Due to the species-specific survival characteristics and ubiquitous distribution of certain biotypes in the environment, it is not recommended that the fecal streptococci be used as the sole fecal pollution indicator. Other fecal indicators should be used concurrently if using the



fecal streptococci to investigate water quality (American Public Health Association, 1976). Improved assurance of the microbiological safety of raw water can be gained by using both the thermo-tolerant coliforms and fecal streptococci as fecal pollution indicators.

e. Sporeformers

(i) Definitions and Source of Indicators. Anaerobic (genus Clostridium) and aerobic (genus Bacillus) spore-forming species can be applied as indicators of pollution in the examination of drinking water. Bacillus species often constitute a considerable part of the colonies counted on plates, especially at 37°C; these organisms can accumulate in sand filters, and a sudden increase in numbers can indicate a breakthrough of the filter. However, an increased number of aerobic sporeformers may also indicate specific pollution (Schubert, 1975a); and the species demonstrated may give an indication as to the source, B. licheniformis being associated mainly with sewage; B. cereus, B. megaterium, and B. sphaericus with soil; and B. brevis with filter sand (Bonde, 1977).

The enumeration of anaerobic sporeformers (clostridia) is based either on counting all sulfite-reducing clostridia that grow at 37°C or on a specific count of C. perfringens.

A short definition of C. perfringens applicable in water quality examination is: gram-positive, anaerobic, sporeforming (although spores are infrequently seen), non-motile rods, which reduce sulfite to sulfide, give stormy fermentation on milk, produce lecithinase, hydrolyze gelatin, ferment sucrose but not mannitol, and do not form indole. Demonstration of sulfite reducers necessitates pasteurization of the sample to avoid interference from non-sporeforming organisms (Vibrio, Salmonella, Arizona, Edwardsiella, Citrobacter, Proteus mirabilis and P. rettgeri) that can form H<sub>2</sub>S from inorganic or organic sulfur compounds. A wide variety of clostridia can reduce sulfite at 37°C (Bonde, 1962), including C. perfringens, C. sporogenes, C. feseri, C. fallax, C. septicum, C. sphenoides, C. bifermentans, C. parasporogenes, C. botulinum, C. oedematiens, C. roseum, C. tertium, and C. cochlearium. Not all of these species are as suggestive of fecal pollution as C. perfringens, which on the other hand is often capricious with regard to sporulation and might in some instances be

lost or suppressed by the other sulfite reducers. The aerobic sporeformers B. polymyxa and B. macerans have sometimes been mentioned as sulfite reducers, but this has not been confirmed (Bonde, 1977).

Applying selective media and procedures, combined with incubation at 48°C, reduces the number of species enumerated to five, of which C. perfringens is more important in polluted waters than the other four species (C. bifermentans, C. feseri, C. sporogenes, and C. tertium), all of which generally grow more slowly.

(ii) Sources and Significance of C. Perfringens in Water Examinations. Bonde (1962) gives a review of the classification, production of toxins, and pathogenicity, as well as of the occurrence in soil, water, and sewage of this organism. The most controversial point is whether this organism is really ubiquitous and mainly found as spores in nature, or dependent upon pollution and found as vegetative forms in the neighborhood of the source of pollution.

Before 1900, C. perfringens was considered to be primarily a fecal and pathogenic organism and, as such, to have greater indicator significance than the coli bacteria. Pollution by sewage could be detected at a ratio of 1:500,000 by means of the "enteritidis test" (for C. perfringens) which was 25 times more sensitive than chemical tests. Wilson and Blair (1925) considered the demonstration of cells in the negative form to be particularly valuable, and stressed that C. perfringens is an organism of indisputably fecal origin that is of great importance for the detection of intermittent and occasional pollution. Many others (cf. survey by Bonde, 1962) considered a test for C. perfringens to be a valuable supplement to other examination methods. Windle Taylor (1958) emphasized that when water is satisfactory from a sanitary point of view according to all other criteria, it has never been possible to demonstrate the presence of C. perfringens, and that this organism is a particularly useful indicator in cases where the coli-aerogenes group fails.

Willis (1956) expressed more negative assessment of C. perfringens as an indicator after finding this bacterium in large numbers in soil samples from areas around boreholes. He also found poor correlation between counts of coliforms and of C. perfringens and showed that filter sand contained this organism in great numbers. He concluded from

his counts of vegetative cells that C. perfringens is able to multiply in tapwater. Windle Taylor (1958) also found C. perfringens in samples of filter sand, vegetative cells being predominant. However, considering that waterbearing strata are subject to contamination and that defects in sand filters are common, it is surprising that such adverse interpretations are made from these findings.

C. perfringens is also very important in water samples because it may cause "false positives" in the lactose fermentation test for coliforms more frequently than any other single organism, sometimes in nearly half of the samples. Windle Taylor (1958) considered this species a predominant cause of false positive results in testing filtered and chlorinated waters: C. perfringens accounted for 22.7 percent of the total of 32.6 percent false positive reactions.

Bonde (1962) did not find a regular correlation between counts of C. perfringens and E. coli, but stressed that such a correlation should not be expected. The initial numbers of both species are functions of fecal pollution, but the ecology, persistence, and survival of the two differ markedly. C. perfringens and E. coli must both be considered fecal organisms and are excreted together with potentially pathogenic organisms. On the whole, the counts of thermo-tolerant coliforms are usually greater, by a factor of about 100, than counts of C. perfringens regardless of whether the latter are done with nonpasteurized samples or as counts of spores. In some cases, however, C. perfringens may give higher counts than E. coli and may even be present despite negative tests for E. coli in as much as 46 percent of tapwater samples, whereas among water samples in general that contain E. coli, 85 percent lacked C. perfringens (Bonde, 1962).

Those opposed to the use of C. perfringens as an indicator have suggested that its numbers, in samples, are too small to be useful. However, improved methods now often reveal higher numbers of C. perfringens than of E. coli (Bonde, 1962).

(iii) Enumeration Techniques. Several methods and media are available for C. perfringens counts (Bisson and Cabelli, 1979; Bonde, 1962; British Department of Health and Social Security, 1969; Hirn and Raevuori, 1978; Windle Taylor, 1958). The methods differ mainly in using media that are liquid or solid and rich or lean in nutrients, in incubation at 37°C or at 45 to 48°C, and in pasteurization

of the inoculum or not. Liquid media are used for most probable number methods and solid media are used for colony counts.

An improved version of the Bonde pour-tube method uses a lean medium (meat extract 1 percent, peptone 1 percent, agar 0.75 percent, pH 7.2, in 10-ml amounts in tubes to which is added 2 ml 1 percent anhydrous sodium sulfite solution, two drops of 5 percent ferrous alum, and 5 ml inoculum). Ten tubes of pasteurized (at 80°C for 5 min) as well as of nonpasteurized samples are incubated at 48°C for 24 h. Based on a study of about 13,000 counts and confirmation by gram stain, motility, stormy fermentation-reaction, and fermentation of mannitol, colonies that had attained a size of more than two mm were confirmed as C. perfringens in more than 90 percent of cases, except in samples from polluted fresh water courses (75 percent). Lack of confirmation was, in most cases, due to failure to grow and not to the presence of other sulfite-reducers. The method can, therefore, be applied with good results as a presumptive test without confirmation. The same medium can also be used with membrane filters laid onto it.

(iv) Conclusions. Enumeration of C. perfringens compares to the requirements for an ideal indicator system as follows:

1. An indicator bacterium must always be present when pathogenic organisms are present. C. perfringens is a fecal organism and will be excreted together with possible enteric pathogenic organisms.
2. It must be present only when the presence of pathogenic organisms is a possibility. This rigorous requirement is not fulfilled by any of the known indicator species; Bonde (1977) has shown that C. perfringens is widespread but not ubiquitous, so it meets this criterion as well as other established fecal indicators.
3. It must be excreted in greater numbers than the pathogenic organisms. This appears to be true of C. perfringens now that the methods developed are yielding numbers comparable to those for E. coli in feces.

4. It must be more resistant, both to disinfectants and to hostile aqueous environments, than the pathogens. This condition is fulfilled by C. perfringens to a greater extent than by any other indicator.
5. It must display characteristic and simple reactions during growth, enabling rapid and, preferably, unambiguous identification; this is the case with C. perfringens.
6. The growth of the indicator bacterium should be independent of other species in the presumptive medium. This requirement is fulfilled by C. perfringens in sulfite-alum agar at 48°C.

C. perfringens may be preferable to E. coli as an indicator when examining samples that may contain substances toxic to microorganisms, including samples of chlorinated water, and in the examination of samples for which transportation problems are such that the samples cannot be analyzed within 12 h of collection. In all single examinations and all first examinations of untreated water, determinations of C. perfringens should be added to the usual tests. This species may be an especially valuable indicator in exceptionally hot or cold climates.

(v) Summary. Anaerobic, sporeforming clostridia can be applied as indicators of pollution in the examination of drinking water: the species of choice for this purpose is C. perfringens. Techniques for the enumeration of this fecal organism have been so refined as to allow them to be used with as much sensitivity as the methods for E. coli, in most cases. In general, good correlations are not found, nor are they expected, between C. perfringens and E. coli in environmental samples. C. perfringens is evidently widespread, but not ubiquitous in the environment; its detection in water must be considered evidence of fecal contamination.

## 2. Proposed Viable Indicators

For any of several reasons, the organisms in this group are not presently included under the designation, "established viable indicators." In some cases, the detection method is

too complex or time-consuming, or too recently developed. Not enough is known about some of the organisms to enable correct interpretation of results in all situations. Whatever drawbacks currently preclude their use may or may not be subject to revision in the future. The following critical evaluations will attempt to discern their utility and scope of application as indicators in light of the latest data.

a. Coliphages. Twort in 1915, and d'Herelle in 1917, were the first to report bacterial lysis caused by a virus. d'Herelle named these viruses "bacteriophage" (i.e., bacteria-eating); the name is frequently shortened to "phage."

Phages, each of which are specific for a single species of bacterium, have been isolated from fresh and seawater, as well as from wastewater. Those which attack Salmonella, Shigella, Pseudomonas, Staphylococcus, Vibrio, and other bacteria are described in the literature, as are phages that attack yeasts and cyanobacteria.

Best characterized are the "coliphages" (phages which infect E. coli), especially the T-phages; others designated MS<sub>2</sub>, f2, and  $\phi$ X174 have also been studied extensively. Coliphages are shed at high levels by humans and other warm-blooded animals and are present in the feces whether or not enteroviruses are.

The coliphages are not usually specific as to the species of animal in whose feces they occur, but they are quite selective as to which strains of E. coli they will infect. This specificity is determined by the coat protein (e.g., the tail structures in the case of the T-phages) of the virus particle, which must attach to a homologous receptor on the surface of the bacterial cell before the viral nucleic acid can be injected into the host. Only those coliphages that express themselves overtly (i.e., carry out a full replicative cycle) in cell culture can be used as indicators. Those that do not cause cell lysis within the 6 h incubation period -- lysogenic phages -- are not useful indicators.

The presence of coliphages (shed in all human feces) indicates that fecal material, possibly containing surviving pathogenic enteroviruses, is present. Since at least some coliphages are more resistant to environmental conditions and chlorination than most enteroviruses, the elimination of

the latter can be assumed to have occurred if these coliphages cannot be found. Coliform (especially thermo-tolerant coliform) bacteria are not considered good indicators of enteroviruses because they are much less resistant than enteroviruses to environmental conditions and chlorination (Scarpino, et al., 1972). Detection of waterborne coliphages is easier than enteroviruses because:

1. They are present in greater numbers than enteroviruses in fecal material and therefore, in sewage; and
2. They can be isolated and counted by relatively simple means, and in less time than is required for enteroviruses. Coliphage enumerations can often be accomplished within 4 to 6 h, whereas seven or eight days are required for enterovirus enumerations (Kott, et al., 1978b).

(i) Coliphage Enumeration Techniques. The agar layer method (Adams, 1959) provides an accurate means of enumerating coliphage, and does so within 24 h. The sample is inoculated directly onto a bacterial lawn grown on soft agar (or mixed together with the sample and molten agar) in petri plates, and plaques are counted. However, a preliminary concentration step must be applied before this technique can be used with large volumes of water containing small numbers of bacteriophage.

The most probable number (MPN) method has been used successfully for animal virus tissue culture enumerations and could detect coliphage in fresh water, seawater, and wastewater in numbers as low as two plaque-forming units (pfu) per 100 ml when E. coli B was the host strain (Kott, 1966). This technique has, accordingly, been recommended for use with larger volumes of up to one liter of water and provides for enrichment of phages. It calls for inoculation of sample into a 5-tube, 3-dilution series, using double and single strength Phage Assay Base (PAB) broth (Fisher Scientific Co., Pittsburgh, Pa.) as the enrichment medium. Culture tubes are incubated for 16 h at 35°C after which time a loopful from each tube is transferred to freshly seeded host E. coli plates and incubated for 6 h at 35°C. Results are computed from coliform MPN tables (Kott, 1966). Although the MPN method can be used with any E. coli strain, the best results in the cited study were obtained when E. coli B served as host.

(ii) Preparatory Concentration Techniques. Several techniques are available for concentrating viruses, including phages, which occur in water at extremely low levels [See also Section III.C.2.b]. Gilcreas and Kelly (1955) used alum flocculation and obtained almost 99.99 percent isolation of coliforms and coliphages; they accordingly recommended it for concentrating coliphages. Preformed flocs of aluminum hydroxide, aluminum phosphate, and calcium phosphate are generally used for the concentration and isolation of a great variety of viruses, and have been routinely employed as a step in drinking water treatment.

Sorber and coworkers (1972a) found that the polyelectrolyte (PE) 60 (a cross-linked copolymer of isobutylene maleic anhydride) adsorbed 100 percent of T2 coliphage from large volumes (up to 18 l) of water. These same authors (1972b) employed asymmetric cellulose-acetate membranes (commonly used in reverse osmosis) to collect coliphage T2 and poliovirus from large volumes of water.

Bachrach and Friedmann (1971) used a polyethylene glycol and dextran sulfate 2-phase system as well as zone centrifugation in sucrose gradients to isolate T-even and T-odd coliphages. When acid precipitation was employed, good recoveries were obtained with T2 and T4 phages, but not with T3 and T7 phages due to their susceptibility to the acid.

The method found most suitable for recovering low coliphage numbers from large volumes of water entails adsorption of the phage to a cellulose nitrate membrane filter after increasing the electrolyte concentration (for better adsorptive capacity) by adding 0.1 M  $MgCl_2 \cdot 6H_2O$  to the sample. The sample is filtered through a 50 mm<sup>2</sup> membrane of 0.45 um pore size (or larger membranes if over 20 l are applied); phages are eluted with 10 to 15 ml of 3 percent beef extract (pH 9.0). The eluate is examined either by the direct plaque count or by the MPN method (Vajdic, 1970). E. coli B host cultures were used with this method.

(iii) Occurrence and Persistence of Coliphage and Enterovirus in Different Water Sources. Types and numbers of coliphages present will vary depending on the source of the water to be tested -- whether taken, for example, from stream water, wastewater effluent, or a sewage lagoon. Therefore, the most appropriate bacterial host strain will depend on which coliphage types are likely to predominate,



depending upon their relative resistance to environmental (and disinfection) stresses, among other factors. Although most investigators use host bacterial strains susceptible to the T-phages, only 11 percent of hundreds of E. coli (differentiated by IMViC) strains isolated demonstrated susceptibility to the T-series. Moreover, the RNA bacteriophages f2 and MS<sub>2</sub> are more resistant than the other coliphages to chlorination.

Vaughn and Metcalf (1975) studied the presence of coliphages in an estuary polluted with sewage effluent. By testing samples with three host E. coli strains over a three-year period, they found that the dominant coliphage type shifted from one year to the next; this suggested that a host system selected on the basis of past experience might prove ill-suited to present needs. Their studies also revealed that coliphages were capable of multiplying in polluted estuarine waters containing susceptible host cells. They suggested that, due to the potential for coliphage replication in certain waters, coliphages might not always be used reliably to indicate the presence of enteric viruses in water. Cleaner quality waters, however, may show no such multiplication because coliphages infect and replicate only in growing cells and only under very restrictive conditions of pH, temperature, and more.

Ratio of coliphages to enteroviruses also vary among water sources. A three-year study of wastewater effluents found that while the comparatively small number of enteroviruses underwent seasonal fluctuations, the comparatively large number of coliphages ( $\sim 10^3$  to  $10^4$  times as many) remained steady (Kott, et al., 1978a). However, levels of both poliovirus 1 and coliphage f2, isolated from an experimental oxidation pond, remained stable over a period of several months; following oxidation pond treatment the coliphages exhibited higher resistance to chlorination. Sewage lagoons appeared to reduce enteroviruses and coliphages to approximately the same degree (about two orders of magnitude). But, when poliovirus 1 (strain LSc) and coliphage f2 were kept in tapwater and oxidation pond samples in the dark at room temperature, the poliovirus was totally inactivated in < 150 days in both sample waters, whereas the f2 remained viable for over 300 days in both samples [See also Section E.1.d]. Creek and stream waters often contain coliforms, coliphages, and enteroviruses: there may be from 10 to  $10^7$  times as many coliphages as enteroviruses present. Poliovirus survived < 217 days in dry sand, whereas coliphage persisted for several hundred days. In effect,

the physical and chemical quality of the water will influence, to a much greater extent, the numbers of enteroviruses recovered than it will the numbers of coliphages.

(iv) Summary. Coliphages (phages that infect E. coli) are indicators of the possible presence of enteroviruses in water because they are shed in the feces of humans and warm-blooded animals and may be more persistent than enteroviruses under adverse conditions (including disinfection). Coliphage numbers may range from a few per liter in streams and rivers to as many as  $10^6$  per ml in wastewater (where there has not been substantial dilution). Coliphages can be quantified directly by the plaque technique if numbers are high; low numbers necessitate use of the MPN method; either technique may be preceded by some method for concentrating the phages. The simplest method is that of adsorption to a cellulose nitrate membrane filter followed by elution in a small volume of fluid. Using coliphages to indicate the absence of enterovirus from drinking water is inexpensive, does not require a high level of operator skill, and yields results within 24 h. There are, however, circumstances under which coliphage detection may not accurately indicate the presence of enteric viruses.

b. Vaccine Polioviruses. A criticism frequently leveled at the microbiologic indicators of water quality presently in use today, is that their occurrence is poorly correlated with the incidence of human enteric viruses in water (Berg and Metcalf, 1978). The assertion may be true, but the criticism is not entirely valid, for indicators now in general use are expected to signal a variety of undesirable conditions without necessarily being absolutely related to the presence of any one specific pathogen. If one wants an indicator specifically to predict the incidence of human enteric viral pathogens, the indicator in question should always be present when these pathogens are present (Berg, 1978). The nonpathogenic, vaccine strains of the polioviruses are human enteric viruses and might thus serve as specific indicators of the virologic safety of water (Katzenelson, 1976).

More than 100 different virus types may be encountered in waters contaminated with human wastes, although only the hepatitis A virus has been demonstrated to be transmitted by water (Berg and Metcalf, 1978; Katzenelson, 1978; Melnick, et al., 1978). Most commonly encountered in water are the

enteroviruses (polioviruses, echoviruses, and coxsackieviruses); but the reoviruses, adenoviruses, hepatitis A virus, and gastroenteritis viruses may also be present [See Sections B.1.b and B.1.d] (Center for Disease Control, 1978d; Katzenelson, 1978; and Melnick, *et al.*, 1978). The concentration of such viruses in feces-contaminated water depends upon the number of infected individuals in the population, independent of the incidence of clinical symptoms.

The concentration of any virus, once introduced into water, can only remain at the initial level or decline (Berg, 1978; Katzenelson, 1978). Viruses do not replicate outside a susceptible living host, whereas indicator bacteria can multiply in nutrient enriched waters and thus, exaggerate the perceived risk of viral contamination (Berg, 1978; Geldreich, 1978). Enteric viruses are also more resistant to environmental extremes and to disinfection, so that enteric viruses may persist in water long after all indicator bacteria have been eliminated (Berg, 1978; Berg and Metcalf, 1978; Katzenelson, 1976; U.S. Environmental Protection Agency, 1978). These are general reasons that the occurrence of bacterial indicators cannot always be used to signal the presence of viruses in water, as has been demonstrated by outbreaks of hepatitis A resulting from consumption of shellfish grown in contaminated surface waters that were believed to be free of total coliforms (Berg and Metcalf, 1978; Portnoy, *et al.*, 1975). The presence of viruses in water may best be monitored using a viral indicator group.

In comparison to the traditional coliform indicators of water quality, the concentration of viruses in wastewater is quite low. Estimates of 100 to 400 virus units per liter in the U.S. (U.S. Environmental Protection Agency, 1978) and 100 to 10,000 per 100 ml in other countries (Fattal and Nishmi, 1977; Katzenelson, 1978) have been reported. After wastewater treatment and dilution in the environment followed by exposure to environmental extremes, the concentration of the remaining viruses in the water supply will be still lower. Thus, it is difficult to estimate the extremely low numbers of viruses that might occur in drinking water.

Given the many types of viruses that may enter water, the detection of any single viral pathogen is a formidable task, and the detection of a great range of virus types would be too complicated for routine laboratory analyses.

What is needed is a simple, reliable virus indicator system that consistently occurs in feces-contaminated waters and would dependably serve notice of the presence of viral pathogens.

In countries using the live trivalent oral polio vaccine (TOPV), the predominant enteric viruses isolated from sewage have been the three serotypes of the vaccine poliovirus (Fattal and Nishmi, 1977; Katzenelson, 1976; Katzenelson and Kedmi, 1979; U.S. Environmental Protection Agency, 1978). These virus isolates are shown to be vaccine-associated on the basis of the presence of distinctive genetic markers. Vaccine-derived poliovirus is assumed to be nonpathogenic, although of 142 cases of poliomyelitis reported in the U.S. from 1970 to 1978, 44 have been vaccine-associated; thus, the vaccine virus may be pathogenic for a small susceptible portion of the population (U.S. Environmental Protection Agency, 1978). The vaccine virus should not exhibit seasonal fluctuations in concentration, whereas the occurrence of wild viruses peaks in the late summer and early fall (Fattal and Nishmi, 1977; Katzenelson, 1976; U.S. Environmental Protection Agency, 1978).

Vaccine polioviruses are hardy, safe to handle, and easy to enumerate in the laboratory, whereas simple cell culture recovery systems for many other viruses are nonexistent. Because they are convenient laboratory tools, much is known about their survival in the environment, their responses to disinfectants, and methods for their recovery from environmental sources. It is for these reasons that the vaccine-derived polioviruses are attractive candidates to serve as viral indicators. Other investigators (Melnick, *et al.*, 1978) also have realized the value of using the readily demonstrable enteroviruses as indicators.

The major disadvantage of using a virus system for determining water safety is the time involved in performing virological assays, which usually takes more than 24 h and often requires three to seven days after a 24 to 48 h concentration step (Katzenelson, 1976). If polioviruses are to serve as useful indicators, a more rapid detection method is required. A proposed method uses the fluorescent antibody (FA) technique which identifies the virus after 18 to 24 h (Katzenelson, 1976). With the FA method, poliovirus antigens can be demonstrated after 6 to 9 h, but quantitative results require the complete 18 to 24 h incubation. An improvement of the original FA method incorporates tragacanth gum into the micro tissue culture medium, analogous to the

incorporation of agar into the plaque assay medium (Kedmi and Katzenelson, 1978). The resulting increase in viscosity allows the resolution of closely spaced plaques (preventing overlapping of neighboring plaques) and eliminates scattering of infected cells. Thus, a more accurate enumeration of plaque-forming units is achieved.

In countries routinely administering the TOPV to infants, in three to four challenges during the first year of life, a constant seeding of wastewater occurs (Berg and Metcalf, 1978; Katzenelson, 1976; Katzenelson and Kedmi, 1979; U.S. Environmental Protection Agency, 1978). The vaccine virus, like the wild virus, replicates in the human intestinal tract and is shed in high numbers ( $10^5$  to  $10^6$  plaque-forming units per g of feces) for several weeks after the initial administration. Vaccine-derived poliovirus should thus, be expected to occur consistently in the sewage of countries using the live attenuated virus.

In one study (U.S. Environmental Protection Agency, 1978), vaccine-derived poliovirus could be isolated from sewage when as few as 0.3 percent of the local population were vaccinated. In Israel, viruses were isolated from sewage at different locations; among the 489 isolates, 74 percent of those identified were polioviruses. However, in Hungary only 19 percent of the identified viral isolates were vaccine-strain polioviruses (Palfi, 1971). In this study, poliovirus was the prevalent type found in sewage only after the compulsory polio vaccination campaigns were carried out during the winter months. Reoviruses were isolated throughout the year, but were isolated in highest concentration only after excretion of the vaccine virus ceased. The same pattern was observed with other wild viruses, suggesting that vaccination of populations with live polioviruses alters the incidence of wild viruses within a population. This observation may be due to the very rapid destruction of cells, by polioviruses, during enumeration assays (Palfi, 1971) or to the displacement of other virus types in the human population. Administration of live vaccine virus also alters the ratio of indicator bacteria to viruses entering sewage (Berg and Metcalf, 1978). Intermittent vaccination programs would cause poliovirus predominance only seasonally, whereas continuous vaccination programs, as in the U.S. and Israel, should cause poliovirus to predominate throughout the year (Berg and Metcalf, 1978).

In Israel, where TOPV is administered year-round, raw sewage samples from both large cities and small communities were analyzed for poliovirus (Katzenelson and Kedmi, 1979).

In this study, poliovirus was isolated from only 50 percent of the samples assayed. Negative results may have occurred because the wastewater contained a low concentration of polioviruses that was beneath the limit of sensitivity of the investigators' detection system. Detectable viruses were absent not only in small communities where the infant population could be expected to be low, but also in the large communities that had a significant number of infants who had received the TOPV.

In order for vaccine polioviruses to serve as indicators for enteric viruses, they must be present in all waters receiving fecal discharges. Although vaccine-derived poliovirus is isolated from sewage more often than other viruses, it is not always present (as is true of E. coli) in detectable quantities; therefore, negative test results would not guarantee virus-free water (Katzenelson, 1976). Vaccine polioviruses could not be expected to serve as suitable indicators in small communities lacking a significant infant population, in countries administering TOPV only seasonally, or in countries and communities using a killed virus vaccine instead of TOPV. However, the vaccine-derived polioviruses would have been expected to predominate in raw sewage from large cities in Israel, where the vaccine is in continuous use. The inability to detect vaccine polioviruses in many of such samples suggests that this potential indicator system is not predictably better correlated, compared to others already in use, with the incidence of human enteric viruses in water (Katzenelson and Kedmi, 1979).

Summary. Vaccine polioviruses are prevalent in receiving waters in areas where live trivalent oral polio vaccine is used for immunization. These viruses have been considered for use as indicators of human pathogenic enteric viruses. They are frequently detected in sewage, but recent data suggest that there are significant numbers of cases where no polioviruses were detectable in raw sewage in urban areas where the oral polio vaccine was in constant usage. As a result, the vaccine polioviruses do not appear to offer increased reliability over conventional bacterial indicators for enteric viruses in water.

c. Pseudomonas Aeruginosa. Within the genus Pseudomonas, the species of concern to public health is P. aeruginosa [See Section B.1.a(ix)]. The most common diseases

caused are eye, ear, nose, and throat infections, although general infections and septicemia are also possible (Caselitz, 1966). Given the opportunity to multiply in foods, P. aeruginosa may cause diarrhea after ingestion of the contaminated food (Caselitz, 1966; Kubota and Liu, 1971). Since this organism can grow under low nutrient concentrations (i.e., in distilled water), it warrants consideration for use in routine monitoring of finished water.

P. aeruginosa has been defined by a working group of the International Standards Organization as:

"Gram-negative, non-sporing rods which are oxidase and catalase positive; capable of growth at 42°C, but not 4°C; usually produces a water-soluble, fluorescing pigment; exhibits oxidative metabolism as indicated by the Hugh and Liefson test; reduces nitrate beyond the stage of nitrite, and produces ammonia from the breakdown of acetamide; gelatin is liquified, casein is hydrolyzed, but starch is not hydrolyzed. Pyrocyanine is produced by more than 90 percent of strains."

The ecology of P. aeruginosa is not well known. Although the organism is found, regularly, in surface waters that receive wastewater effluents (mainly of urban origin) [See Sections A.Intro. and A.2.a], it is not clear whether this is necessarily the source of all P. aeruginosa. Recovery of Pseudomonas biotypes in areas untouched by humans indicates that environmental factors alone may support and even favor mass development of P. aeruginosa. Results from groundwater surveys show that P. aeruginosa is rarely found in undisturbed groundwater and that the presence of P. aeruginosa nearly always indicates contamination by surface water (Hoadley, 1977; Schubert and Blun, 1974a; Schubert and Scheiber, 1975). In addition, the organisms are not frequently found in groundwaters infiltrated with surface water or river water, which suggests that they are effectively eliminated during passage through the soil (Schubert and Blun, 1974a; Schubert and Scheiber, 1975) [See also Section A.1.e].

(i) Enumeration Methods. The most probable number (MPN) method is routinely used to enumerate P. aeruginosa, with enrichment either in nutrient broth containing malachite green dye incubated at 37°C (Schubert and Blun, 1974b) or in asparagine broth incubated at 35 to 37°C (American Public Health Association, 1976). Enrichment in Drake's medium 10

also has been shown to yield good results (reviewed by Hoadley, 1977). From there, cells are streaked onto a selective medium (MacConkey's agar, cetrinide agar, etc.), and finally identified by tests for fluorescein formation (on King's medium A) and/or pyocyanin formation (on King's medium B) as well as ammonia production from acetamide (which is of particular importance with apyocyanogenic strains (Schubert, et al., 1975)).

Several membrane filtration methods, based on the mPA medium of Levin and Cabelli (1972), are in current use. The mPA medium contains antibiotics to reduce background growth (sulfapyridine, kanamycin, nalidixic acid, and acidione) along with indicator systems to distinguish P. aeruginosa from colonies that ferment lactose, sucrose, and xylose, and produce hydrogen sulfide. Membrane filters are placed on the agar medium and plates are incubated at 41.5°C for 48 h. A recent modification of this procedure, known as mPA-C (Brodsky and Ciebin, 1978), allows presumptive identification of P. aeruginosa within 24 h at an incubation temperature of 41.5°C.

(ii) Evaluation as an Indicator. Pseudomonas is an organism worthy of attention in the area of finished drinking water, largely because it has been found capable of growth along portions of the distribution system, particularly under conditions of low water flow and where dead end pipes are situated [See Sections F.2.a and F.3.a]. Treatment processes such as ion-exchange systems [See Section G.2] and many filtering devices [See Section E.4], in addition to situations where warm water flows through some types of plastic tubing or containers, can be especially favorable to the growth of Pseudomonas. It has been suggested (Labonde and Festy, 1979) that, in certain cases (e.g., in bottled water, in epidemiological studies, in new homes, in high risk areas, and in water destined for therapeutic purposes), drinking water should be monitored for Pseudomonas.

(iv) Conclusions. P. aeruginosa is a potential pathogen, especially if ingested in high numbers, as can occur after enrichment in foods. Therefore, it must be considered undesirable in drinking water and should be absent from sample volumes of at least 100 ml of finished water. The presence of P. aeruginosa in drinking water almost always can be traced either to direct contamination by surface



water or to dissemination from a primary locus of contamination to other parts of the distribution system, reservoirs, or treatment facilities.

(v) Summary. Pseudomonas aeruginosa is an important opportunistic pathogen of humans. It may or may not be of fecal origin in water, but it can grow even at low nutrient levels, sometimes reaching high numbers under favorable conditions, some of which have been described here. Methods for the detection of Pseudomonas are sufficiently developed that the organism should be routinely monitored in high risk areas, in the distribution system, and in water destined for therapeutic use.

d. Klebsiella. The genus Klebsiella is a member of the family Enterobacteriaceae and is composed of non-sporeforming, non-motile, capsulated gram-negative rods (Ørskov, 1974).

Some species of the present genera Klebsiella and Enterobacter, with IMViC type --++, were traditionally classified as Aerobacter aerogenes. Later, the motile strains were designated Enterobacter (including A. aerogenes), while the non-motile organisms were placed in the genus Klebsiella. Another major difference between Enterobacter and Klebsiella is that the latter lack ornithine decarboxylase.

According to the Edwards and Ewing classification, which is widely accepted in the U.S. (especially in the clinical laboratory), the klebsiellae are divided into three species: K. pneumoniae, K. ozaenae, and K. rhinoscleromatis. This classification has been adopted by Bergey's Manual of Determinative Bacteriology, (Buchanan and Gibbons, 1974); however, alternate classification systems exist. The type species K. pneumoniae, is the predominant species isolated from environmental sources and is identified in 95 percent of clinical Klebsiella isolates in the U.S.

Biochemical procedures for differentiating K. pneumoniae are discussed elsewhere (Gellman, 1975; Dufour and Cabelli, 1976; Vlassoff, 1977). This organism is characterized as a non-motile rod that ferments lactose with the production of gas and does not decarboxylate ornithine. Its typical IMViC reaction is --++. Other tests useful for its identification are urease (slow +), H<sub>2</sub>S (-), oxidase (-),

gelatin liquefaction (-), KCN (+), lysine decarboxylase (+), arginine dihydrolase (-), and esculin hydrolysis (+).

Klebsiella isolates may be classified, serologically, on the basis of their heat-labile capsular (K) and heat-stable somatic (O) antigens. Presently, there are 72 known capsular serotypes and five O antigens. Rennie and Duncan (1974) found that biotypes and serotypes vary independently so that the two methods, used in conjunction, distinguish among more types than either method used alone.

Klebsiellae are widespread in normal humans and animals, but are also known to be opportunistic pathogens capable of causing infections when normal host defenses are weakened (Bagley and Seidler, 1978; Gellman, 1975). Furthermore, since the advent of antibiotic therapy, these organisms have shown increasing resistance to antibiotics because of their ability to accept and transfer plasmids (R factors) which carry determinants for multiple drug resistance.

(i) Sources of Klebsiella in the Environment. Klebsiella may originate from vegetable as well as animal sources (Duncan and Razzell, 1972). Klebsiella of animal origin, in the environment, most frequently derives from feces, but not all fecal samples yield Klebsiella. On the other hand, colonization of the human intestines, so that Klebsiella predominates, is a known, but abnormal phenomenon (Dufour and Cabelli, 1976; Knittel, et al., 1977; Vlassoff, 1977).

Regardless of its ultimate source, Klebsiella is ubiquitous in the environment (Dufour and Cabelli, 1976; Knittel, et al., 1977; Seidler, et al., 1977; and Vlassoff, 1977). These organisms are commonly associated with living trees and have been found in samples of water, soil, needles, and bark from different forest environments, including virgin forests of British Columbia. High densities of coliform bacteria, predominantly Klebsiella, can be found in pulp and paper mill effluents. Other carbohydrate-rich nutrient sources such as waste effluents from sugarcane, sugar refining, and kelp processing also yield high numbers of Klebsiella, far outnumbering the E. coli population. Significant numbers of Klebsiella have been isolated from a variety of market vegetables and seeds, dairy products (with positive coliform counts), and pet turtles.

The ability of Klebsiella to grow in nutrient-rich waters may be the cause of its frequent predominance over

E. coli in surface waters receiving wastewater discharges (Dufour and Cabelli, 1976; Seidler, et al., 1977). The capsule on the Klebsiella cell seems to impart some relative chlorine resistance, so that Klebsiella may predominate over E. coli in chlorinated water derived from raw water in which E. coli was the more numerous (Ptak, et al., 1973).

Total coliform counts exceeding U.S. federal regulations were detected by Seidler and coworkers (1977) in public and private drinking water systems that utilized redwood storage tanks. The coliform isolates were most often identified as K. pneumoniae and Enterobacter species. E. coli was isolated only rarely and was most likely due to more immediate fecal contamination. It appeared to the authors that specific nutrients in wood, trees, vegetables, and other plant matter selectively support coliforms of the tribe Klebsiellae.

(ii) Significance of Klebsiella in Water Bacteriology. Given the definition of the genus, virtually all Klebsiella organisms will yield a positive result in the total coliform test [See Section C.1.b]. Not all klebsiellae give a positive result in the thermo-tolerant coliform test [See Section C.1.c], apparently because some cannot grow at 44.5°C, however, most thermo-tolerant coliforms other than E. coli are Klebsiella (Dufour, 1977). Those klebsiellae which can grow at 44.5°C and are thermo-tolerant coliform-positive are not necessarily of fecal origin. Nevertheless, those which have been selected or adapted to growth in low temperature environments tend to be negative in the fecal coliform test (Naemura and Seidler, 1978), so there is a measure of correlation between the test result and fecal origin.

Members of the genus Klebsiella are not reliable indicators of sanitary quality or fecal contamination of water, for they do not meet several criteria of ideal indicator organisms. Detection of Klebsiella in water is more probably indicative of certain types of industrial pollution. Many studies have demonstrated high densities of Klebsiella, and few E. coli, in wood processing and other nutrient-rich effluents that were not known to have received human or animal wastes. Therefore, high coliform or fecal coliform counts in waters receiving such industrial effluents (unless sanitary wastes from the plant are included) should not be considered indicative of the presence of other microbial pathogens. Alternately, it has been suggested that

nutrients arising from vegetable material may selectively favor multiplication of the klebsiellae and that this could mask the presence of other fecal organisms (Dufour and Cabelli, 1976; Seidler, et al., 1977). Klebsiella may also inhibit the growth of other bacteria (Ptak, et al., 1973).

Klebsiella, used in conjunction with thermo-tolerant coliforms or E. coli, can be a useful indicator for monitoring certain industrial discharges and their receiving waters. Primary isolation methods, by which members of the genus Klebsiella can be enumerated and differentiated for this purpose, are obviously needed. Proposed media and methods have been reviewed by Vlassoff (1977). Sufficient data, on which to base a selection, are not yet available.

(iii) Conclusion. The widespread presence of Klebsiella in the environment is well known. Although carried by many healthy individuals, members of the genus Klebsiella are opportunistic human and animal pathogens and have become increasingly important as the cause of nosocomial infections. Some Klebsiella strains, readily recovered from environmental sources, have been found to be indistinguishable from clinical isolates when tested biochemically, serologically, and for their ability to grow at elevated temperatures (44.5°C) (Bagley and Seidler, 1978).

As is the case with any opportunistic pathogen, both a compromised host and a sufficient number of organisms are necessary for infection to occur. There is, as yet, no epidemiological evidence to connect the incidence of Klebsiella in drinking water or recreational waters with occurrence of human disease.

The klebsiellae cannot be considered reliable indicators of fecal pollution because: (1) they are not always present or found in high numbers in feces; (2) they are found in large numbers in certain industrial wastes; (3) they are ubiquitous in the environment; and (4) they are able to multiply in nutrient-rich effluents.

The klebsiellae are not thermo-tolerant coliforms; thus, since a large proportion are able to grow at 44.5°C, there has been some controversy about the validity of total and thermo-tolerant coliform tests which include these organisms. Insofar as the organisms detected are recognized as members of the genus Klebsiella, their presence is most likely to signify high nutrient levels in receiving waters or to give evidence of inadequate treatment of industrial wastes.

(iv) Summary. The genus Klebsiella is a member of the coliform group, Klebsiella pneumoniae being the species most predominant in both environmental and clinical isolates. In spite of its significance as a secondary pathogen, it is not entirely suitable as a fecal pollution indicator because: it is not always found in large numbers in feces; it is often found in large numbers in certain industrial wastes; and it is able to multiply in environmental waters rich in carbohydrates.

e. Bifidobacterium. Bifidobacterium, previously known as Lactobacillus bifidus, may have the necessary characteristics of an ideal bacterial indicator of fecal pollution in raw water (Evison and James, 1975). Bifidobacteria derive exclusively from feces and so, would occur only where there has been fecal contamination. Moreover the organisms are present only in very high numbers of  $10^9$  to  $10^{11}$  per gram of feces in humans (Levin, 1977; Cabelli, 1979) and occur, though in markedly lower numbers, in some warm-blooded animals, especially pigs. Both coliforms and E. coli are now recognized as being capable of regrowth in warm, organically polluted waters; conversely, under these same conditions, numbers of fecal streptococci tend to decline rapidly. Bifidobacteria, on the other hand, are anaerobic organisms with fairly specific growth requirements and thus, are highly unlikely to find all the conditions necessary for regrowth in raw waters.

Members of the genus Bifidobacterium have posed classification problems in the past and the nomenclature has been very confused. However, in the most recent edition of Bergey's Manual of Determinative Bacteriology (Buchanan and Gibbons, 1974), the genus has been divided into eleven clearly defined species on the basis of fermentation reactions with eleven carbohydrates. B. bifidum, B. adolescentis, B. infantis, and B. breve are regularly associated with human feces; B. longum, and perhaps B. pseudolongum, may also be isolated from human feces, but are more often found in feces of lower animals, as are B. thermophilum and B. suis; B. asteroides, B. indicum, and B. coryneforme are associated only with insects.

Bifidobacteria are defined as anaerobic, nonspore-forming, non-motile, gram-positive, thick, pleomorphic rods. They may exhibit branching bulbs, clubs, coryneforms, buds, spheroids, and bifurcated Y and V forms when freshly isolated from fecal sources. However, their morphology is

related to nutritional conditions and may be affected by exposure in an aquatic environment and by composition of the culture medium. A calcium deficiency has been said to encourage pleomorphism, but culturing on normal laboratory media, such as MRS broth (De Man, et al., 1960) or differential reinforced clostridial media (DRCM), greatly reduces pleomorphism. Although young cultures of bifidobacteria are gram-positive, cultures older than four days gradually become gram-variable or even apparently gram-negative (Buchanan and Gibbons, 1974). The organisms also are catalase negative, do not reduce nitrates, and produce mainly lactic and acetic acid, but not gas, from glucose fermentation.

(i) Methods for Enumerating Bifidobacterium. Several media have been proposed for isolating Bifidobacterium from water, but only two are in use at present. Both of these media are used with membrane filters, which allows concentration of the sample, as may sometimes be necessary in the case of raw water. The more fully defined isolation medium is based on that proposed by Gyllenberg and Niemela (1959), but has been modified considerably and improved (Bhoonchaisri, 1979) (MGN-Modified Gyllenberg and Niemela medium).

The isolation medium [See Table C.2.e-1 for formulation] is prepared in two parts. After Part A is melted and cooled to 45°C, Part B is added in proportions of 10 ml Part B to 90 ml Part A. Raw water samples are filtered through cellulose nitrate membrane filters (0.45 µm pore diameter, 47 mm filter diameter), the membranes are placed on the solidified medium in incubation tins, and incubated at 37°C for three days. Bifidobacterium colonies appear pink to red and are raised, with a diameter of 0.5 to 1.5 mm. They also will grow equally well in conventional anaerobic jars or in jars containing gas generator packets.

A second medium, YN-6, has been proposed by Resnick and Levin (1977) [See Table C.2.e-2 for medium formulation and preparation]. Membrane filters are incubated, anaerobically, for two days at 37°C. Bifidobacterium colonies will measure 1 to 2 mm in diameter and appear light to dark green, convex, glistening, and smooth.

Colonies from either MGN or YN-6 medium can be identified to the generic level by a simple series of tests.

TABLE C.2.e-1

## MODIFIED GYLLENBERG AND NIEMELA MEDIUM FORMULATION

Part A

Lactose	10.0 g	
$K_2HPO_4$	5.0 g	
$(NH_4)_2SO_4$	4.0 g	
Cysteine hydrochloride	0.4 g	
$MgSO_4 \cdot 7H_2O$	0.2 g	
Tween 80	1 ml	Adjust pH to 6.5.
$FeSO_4 \cdot 7H_2O$	0.01 g	Portion out in 90 ml
NaCl	0.01 g	aliquots. Autoclave at
		121°C for 15 min.
$MnSO_4 \cdot 4H_2O$	0.007 g	
Nalidixic acid	0.007 g	
Biotin	5 ug	
Riboflavin	250 ug	
Pantothenic acid	500 ug	
Neutral red	0.1 g	
Oxoid agar No. 3	12 g	
Distilled water	900 ml	

Part B

Ascorbic acid	10 g	Adjust pH to 6.5. Sterilize
Distilled water	100 ml	by pressure filtration
		through membrane filter of
		0.45 u pore diameter

TABLE C.2.e-2

## YN-6 MEDIUM FORMULATION AND PREPARATION

---

---

Yeast extract	20 g
Peptone	10 g
Lactose	10 g
Casamino acids	8 g
Sodium chloride	3.2 g
Brom cresol green	0.3 g
Distilled water	1 liter

Boil all ingredients for 10 min and cool. Add cysteine hydrochloride (0.4 g), Nalidixic acid (80 mg), adjust to pH 6.9, add agar (15 g) and autoclave at 121°C for 15 min. Cool to 60°C, add 1 ml stock Neomycin (2.5 mg/ml) and dispense into incubation tins.

---

(LEVIN, 1977)



Colonies are grown on solidified DRCM medium and Gram stained (Gram +), spore stained (negative), tested for motility (negative), aerotolerance (negative), and catalase activity (negative). They also are grown in MRS-nitrate broth to check for nitrate reduction (negative). Species of bifidobacteria are identified by their carbohydrates fermentations. Purified isolates are inoculated into MRS-sugar broths that have been modified by replacing 2 percent glucose with other carbohydrates. Positive fermentation is indicated by acid production (chlorophenol red indicator), but no gas production. The isolates are divided initially into four groups, on the basis of arabinose and gluconate fermentation, as in Table C.2.e-3. Identification within groups is achieved by additional tests for lactose, ribose, xylose, mannitol, and starch fermentation (Levin, 1977; Bhoonchaisri, 1979).

(ii) Comparative Evaluations of Proposed Bifidobacterium Culture Media. Results obtained when raw water was examined for Bifidobacterium differ according to the isolation medium used. When the MGN and YN-6 media were compared, using the same sample, the MGN medium yielded higher counts of confirmed Bifidobacterium than the YN-6 medium. Although the YN-6 medium showed higher initial colony counts, a larger proportion of these were aerotolerant (non-Bifidobacterium) organisms. Bhoonchaisri (1979) also showed that the incorporation of a reducing agent (0.05 percent cysteine hydrochloride) into the sample diluent inhibited the growth of Bifidobacterium.

(iii) Evaluation of Bifidobacterium as an Indicator of Fecal Contamination. Studies of Bifidobacterium in fecal specimens from humans have shown that the population is higher and more constant than E. coli or fecal streptococci across all age and ethnic group boundaries (Drasar, 1974; Evison and Morgan, 1978). To quote Cabelli (1979), "Of all the indicator systems, Bifidobacterium appears to be the one most exclusively associated with human, as opposed to lower animal, fecal wastes." It seems that this group may offer potential as a means of distinguishing human from animal pollution and may be very useful, for example, in determining whether domestic waste has entered a stormwater system.

Studies with pure cultures of B. bifidum, B. adolescentis, and B. pseudolongum have demonstrated clearly that

TABLE C.2.e-3

Groupings of Bifidobacterium species

Group	Arabinose	Gluconate	Species
I	+	+	<u>B. adolescentis</u> , <u>B. asteroides</u> , and <u>B. coryneforme</u>
II	+	-	<u>B. longum</u> , <u>B. pseudolongum</u> , and <u>B. suis</u>
III	-	-	<u>B. bifidum</u> , <u>B. breve</u> , <u>B. infantis</u> , and <u>B. thermophilum</u>
IV	-	+	<u>B. indicum</u>

bifidobacteria are unlikely to multiply in raw waters (Evison and Morgan, 1978) because: very little growth occurs above or below the extremely narrow temperature range of 30 to 40°C; no growth can occur above 7 percent atmospheric oxygen; and maximum growth rates can occur only in the presence of high concentrations of proteins or carbohydrates.

One problem that has become apparent in recent studies is that the Bifidobacterium isolation media are not as selective when used with surface waters as they are for sewage samples. Gram-positive rods are commonly found in surface waters and are able to grow on the selective media, so further development of the media is required to overcome this interference.

A further problem, yet to be resolved, is that of the survival potential of bifidobacteria in the aquatic environment. Evison and James (1975), and Opara (1978), found that survival of bifidobacteria was equal to, and sometimes greater than, survival of E. coli in laboratory tests. However, Resnick and Levin (1977), and Cabelli (1979), have suggested that survival of bifidobacteria is poor in the aquatic environment. A possible explanation for this discrepancy might be that the YN-6 medium used by these latter authors contains high concentrations of antibiotics which may interfere with recovery of attenuated bifidobacteria.

(iv) Summary. The genus Bifidobacterium offers potential as a fecal indicator of raw water quality because it derives exclusively from feces (with high numbers in human feces and low numbers in animal feces) and it does not multiply in water (narrow temperature range, low tolerance of dissolved oxygen, high nutrient requirements). Better selective media are urgently needed in order to study the distribution and survival characteristics of the Bifidobacterium group in raw water.

f. Candida Albicans. Candida albicans is a dimorphic yeast which can be differentiated from other fungi by its formation of germ tubes and chlamydo spores (Ahearn, 1974). The former are elongated cell extensions with no constrictions at the point of origin and are induced when young cells are incubated for 1 to 3 h, at 37°C, in calf serum. Chlamydo spores are large, thick-walled, refractile bodies formed on pseudomycelia produced by growth of C. albicans on corn meal or oxgall agar or other appropriate media, at 22 to 26°C.

Although other species of Candida (viz., C. tropicalis, C. parapsilosis, C. guilliermondii, C. krusei, C. pseudotropicalis) are involved in human infection (Ahearn, 1978), C. albicans (syn. C. stellatoidea) is by far the most frequently encountered. While classical pathology involves oral, vaginal, and skin loci (Winner and Hurley, 1964), more recent awareness of the role of C. albicans as a serious opportunistic human pathogen has led to the increasing frequency of reports of systemic infections affecting a wide variety of internal organs (Kashkin, 1974; Ahearn, 1978).

(i) Sources of C. Albicans in the Environment. Human feces contain C. albicans in numbers ranging up to  $10^4$  per g while its occurrence in raw sewage may be as high as 25,000 per l, although a few thousand per l is more common (Buck and Bubucis, 1978). In addition, large numbers of C. albicans are shed by individuals with active cases of diaper rash or vaginitis caused by the yeast. In the latter case, it is estimated that over two million cases of vulvovaginitis of C. albicans etiology occur annually in the U.S. (Ahearn, 1978). Increasing numbers of infections can be correlated with the popularity of oral contraceptives.

The organism is known to occur in domestic and farm animals, although little information is available for these hosts. Feces of beagle dogs contain  $10^3 - 10^5$  cells per g, and over  $10^6$  per g have been recorded from pigeons. C. albicans also occurs in sea gulls and marine mammals (dolphins, porpoises, etc.) although no quantitation has been recorded.

Englebrecht and coworkers (1977) found yeast densities of up to 400 per l in chlorinated sewage effluent. They showed that C. parapsilosis, C. krusei, and other yeasts had a high chlorine resistance compared with coliforms. C. albicans has also been isolated frequently from chlorinated (0.3 - 0.5 mg per l) aquarium water containing marine mammals (J.D. Buck, unpublished data), and chlorine tolerance has been noted (Jones and Schmitt, 1978). The organism is capable of surviving in natural seawater, in situ, for at least six days (Buck, 1978).

(ii) Significance of C. Albicans in Water Microbiology. From the above, it is clear that C. albicans occurs in natural environments; but little is known concerning maintenance of infectivity and infective dose. Since there is no

direct evidence of candidiasis in humans as related to the consumption of water, C. albicans probably does not represent a public health threat in drinking water, although McCabe (1977) suggests the possible use of yeasts as indicators of drinking water quality, based on their chlorine resistance. Bonde (1977) includes "Candida, and yeasts" among agents of waterborne diseases. Brisou (1975) has noted increased incidence of vaginal infections in women using polluted recreational waters. With the necessity for recycling water in some areas, potential microbiological problems must be considered (Lund, 1978). Environmental stress may have a profound effect on the ability to recover indicator bacteria (Bissonnette, et al., 1975). Some reports are available on the occurrence of pathogens in water in which no thermo-tolerant coliforms were detected (Bonde, 1977; Berg, et al., 1978). In fact, the concept of bio-indicators is being reexamined (Hoadley and Dutka, 1977; Pipes, 1978).

(iii) Enumeration of C. Albicans. The definition of C. albicans is clear-cut, unlike that of total and thermo-tolerant coliforms, fecal streptococci or other indicator groups. A standard description and characterization is provided by van Uden and Buckley (1970). In addition, a new method for detection and enumeration of C. albicans (Buck and Bubucis, 1978) has been incorporated into the Environment Canada Microbiology Methods Manual for the Analysis of Waters, Wastewaters, and Sediments and will soon undergo testing in accordance with the American Society for Testing and Materials (ASTM) prior to eventual establishment as a standard procedure. The method has proved useful for assessing bathing water quality (Sherry, et al., 1979).

(iv) Recommendations for Future Research. The significance of C. albicans in raw and finished water would be better understood if some additional research were done. More should be known of the rate at which C. albicans is shed in feces of normal humans and animals and of the role of sea gulls and other birds as sources of this organism in water. Second, the effects on C. albicans from sewage treatment (including chlorination), temperature, salinity, pH, industrial wastes, etc., need further study. It would also be well to determine whether sediments in drinking water collection basins concentrate or protect C. albicans, as occurs with coliforms. Finally, ratios between densities

of C. albicans and accepted bioindicators should be measured for as many situations as possible.

(v) Summary. Candida albicans is a yeast derived from the feces of humans, animals, and birds. Although this organism has not yet been implicated in any drinking water disease outbreaks, it has emerged as a significant opportunistic human pathogen with common occurrence in environmental and wastewaters. Therefore, it would be prudent to occasionally monitor for Candida albicans in raw and finished water. A membrane filter method is now available that is suitable for these analyses.

g. Vibrio. Vibrio species are widely distributed in aquatic environments. Recent studies have shown that Vibrio cholerae, Vibrio parahaemolyticus, and other pathogenic vibrios are found in brackish water and estuarine habitats (Colwell, et al., 1977). Cholera has long been recognized as a waterborne disease; the infectious agent enters water, directly from the infected host or indirectly via wastewater, from areas in which are found clinical cases of cholera, persons in the incubation stage, or healthy carriers. The first documented outbreak of cholera in the U.S. since 1911 (Center for Disease Control, 1978c) has brought into focus the potential for cholera outbreaks in those geographical areas hitherto considered cholera-free because of the assumption that good sanitation practices and high standards for waste treatment provide protection for the community. Two newly described groups, the lactose-positive and Group F vibrios, have been found to be associated with disease in man. Thus, the potential health hazard of Vibrio species, transmitted via the water route, has been well documented and there is now a recognized need to consider vibrios as potentially useful indicator organisms of water quality.

(i) Taxonomy of the Genus Vibrio. The description of the type species, V. cholerae of the genus Vibrio, is as follows: short, curved or straight rods, single or united into spirals, that grow well and rapidly on the surfaces of standard culture media, are asporogenous and gram-negative, and produce L-lysine and L-ornithine decarboxylases, but not L-arginine dehydrolase or hydrogen sulfide (Kligler iron agar). The overall deoxyribonucleic acid (DNA) base composition is about 48 ± 1 percent

guanine plus cytosine. V. cholerae includes strains that may or may not be hemolytic, may or may not be agglutinated by Gardner and Venkatraman O group I antiserum, and may or may not be lysed by Mukerjee V. cholerae bacteriophages I, II, III, IV, and V (Buchanan and Gibbons, 1974; Sebald and Veron, 1963).

V. cholerae strains are grouped into 53 serotypes, based on possession of O antigens. However, the non O-I vibrios, termed NCV, NAG, or non O-I of Heiberg groups I and II, also have been implicated in cholera-like diseases. In addition to the difficulties in assessing potential pathogenicity of the non O-I V. cholerae, Vibrio species often are confused with species of other genera such as Aeromonas, Spirillum, Plesiomonas, and other related groups. A table of features useful in separating these genera has been published elsewhere (Colwell, and Kaper, 1977).

(ii) Enumeration Methods. In order to enumerate Vibrio species in water, enrichment must be done prior to enumeration. For this MPN procedure, a three dilution, five-tube replication series in which 1 liter and 100 ml volumes of water are filtered, is recommended. The volumes employed will vary according to the species of Vibrio (viz. V. parahaemolyticus, V. anguillarum, etc.) and the numbers in which they are present in the sample. The filters are placed in 50 ml of alkaline peptone broth after filtration is completed (Colwell and Kaper, 1977). A third dilution is obtained by inoculation of a 10-ml sample into 10 ml double-strength alkaline peptone broth containing 10 g per 1 peptone (Difco Laboratories, Detroit, Michigan), 10 g per 1 sodium chloride (NaCl), pH 8.4. After inoculation, the enrichment flasks are incubated at ambient temperature (25°C) for 6 to 8 h, followed by 18 h incubation at 35 to 37°C, yielding a combined incubation period of approximately 24 h. The cultures should be streaked onto TCBS agar (Baltimore Biological Laboratories, Div. of Bioquest, Cockeysville, MD) at 6 h and after overnight incubation. Plates should be heavily inoculated from enrichment cultures and incubated at 35°C for 18 to 24 h. V. cholerae typically appear as large, smooth, yellow colonies, slightly flattened, with opaque centers, and translucent peripheries.

For slide agglutination and other identification procedures, colonies should be picked from TCBS and transferred to gelatin neopeptone agar containing no added NaCl. The gelatin neopeptone agar plates should be incubated at 35°C for 18 to 24 h. Gelatinase positive strains that are

also oxidase positive can be tested with polyvalent O group I antiserum by slide agglutination. Non O group I strains should be tested for lysine and ornithine decarboxylase, arginine dehydrolase, and other selected characteristics (Colwell and Kaper, 1977).

Several enrichment broths for V. parahaemolyticus have been suggested. A modification of the arabinose, ethyl violet broth of Horie and coworkers, containing (in g per l): peptone (Difco Laboratories Inc., Detroit, Michigan), 5.0; beef extract (Difco), 3.0; NaCl, 30.0; bromothymol blue, 0.03; ethyl violet, 0.001; and galactose, 5.0, pH 9.0, yields good results (Kaper, et al., 1979). After incubation for 24 h at 37°C, the enrichment broth cultures are streaked onto TCBS and incubated at 37°C for 24 h. Blue-green colonies typical of V. parahaemolyticus can be picked to Brain Heart Infusion Agar for further testing. See Colwell and Kaper (1977) for recommended differentiating features.

Because of their halophilic nature, the lactose positive and Group F vibrios must be cultured on heart infusion agar, which usually contains 0.5 percent or more NaCl, or on a suitable marine agar. Enrichment may be achieved, in the case of the lactose-positive vibrios, by using a marine salts solution (Kaneko and Colwell, 1978) with lactose added as a fermentable carbohydrate in a properly buffered medium. Enrichment methods for both the lactose positive and Group F vibrios, however, have yet to be fully documented.

(iii) Significance of Vibrio Species as Water Quality Indicators. With the geographically widespread occurrence of cholera and cholera-like disease, it is clear that Vibrio cholerae and related vibrios are of immediate, practical interest to public health authorities responsible for water quality. The diagnosis of vibrio-induced disease has increased in recent years, due, in part, to greater awareness of the potential pathogenicity of Vibrio species.

The primary indicator organism for water quality has long been E. coli, the presence of which is considered to signify fecal contamination and the presence of potentially pathogenic bacteria. In contrast to E. coli, however, V. cholerae, V. parahaemolyticus, and the lactose-positive and group F vibrios have been demonstrated to be pathogens and are associated with foodborne disease and wound, ear, and eye infections in man. It would be very useful to develop a "Vibrio Index" for raw quality assessment based on total



vibrio counts. The evidence available to date would suggest that when the total count of vibrios is elevated, the presence of the pathogenic vibrio species is more probable and the human risk factor much greater. The significance of large numbers of vibrios in the aquatic environment, both freshwater and marine, has yet to be determined, so no absolute limits can be set at this time. It is necessary to point out that a correlation between standard pollution indices and numbers of Vibrio species in water or food has not been documented. Quite to the contrary, it has been shown that no relationship exists between the counts of V. parahaemolyticus and E. coli in estuaries. Thus, periodic analyses for Vibrio in raw waters could be a useful adjunct to routine water analyses.

(iv) Conclusions. Vibrios are a potential health hazard in the environment, although their fate and role as pathogens in finished drinking water is largely unknown. In order to determine levels in the environment and to determine whether or not a possibility of this pathogen in finished drinking water exists, the periodic analysis for total vibrios is considered useful.

(v) Summary. Vibrios are geographically widespread pathogens not necessarily associated with fecal pollution. Recent outbreaks of cholera and other Vibrio-associated illness have indicated that these pathogens have significant health implications. Methods for their enumeration are available for freshwater and estuarine species. The presence of large numbers of vibrios in a water sample suggests that pathogenic species of Vibrio may also be present. Inasmuch as established microbial indicator systems are poorly correlated with the incidence of pathogenic vibrios, a Vibrio-specific test affords the only potentially valid basis for predicting the presence of these pathogens [See also Section B.1.a(vii)].

h. Aeromonas. The genus Aeromonas includes straight, gram-negative, facultatively anaerobic rods that closely resemble members of the Enterobacteriaceae, but instead, are included in the family Vibrionaceae (Buchanan and Gibbons, 1974). Unlike the enterics, Aeromonas is motile by means of a polar flagellum; and, more important diagnostically, it is cytochrome oxidase positive. For these reasons, it resembles Pseudomonas; however, the metabolism of Aeromonas is

fermentative as well as respiratory. Like Pseudomonas, it is also capable of utilizing high molecular weight substrates such as proteins (e.g., casein and gelatin), deoxyribonucleic acids, starch, dextrin, and glycerol (Buchanan and Gibbons, 1974; Lennette, et al., 1974). Aeromonas occurs in uncontaminated waters as well as in sewage and sewage-contaminated waters. The organism may be pathogenic for humans, other warm-blooded animals, and cold-blooded animals including fish (Buchanan and Gibbons, 1974; Lennette, et al., 1974). Because of its consistent occurrence in appreciable, but variable, numbers in raw and treated sewage and sewage contaminated waters, the use of Aeromonas as a potential indicator of raw water quality has been considered (Cabelli, 1977).

Among the three species belonging to the genus Aeromonas, only A. hydrophila and A. punctata, as well as their subspecies, are of sanitary importance. Only these two species occur as free-living organisms in water, whereas A. salmonicida and its subspecies are fish pathogens that do not occur in surface waters, unless associated with infected fish. Several subspecies of A. hydrophila and A. punctata may be pathogenic not only for fish, amphibians (e.g., frogs), and reptiles (e.g., snakes, turtles, and alligators), but also for warm-blooded animals including humans, mice, and guinea pigs, when the organisms are ingested or enter the body through a wound; however, only A. hydrophila, subspecies hydrophila, is of concern to human health (Buchanan and Gibbons, 1974; Lennette, et al., 1974; Schubert, 1967a). This organism has been isolated from a wide variety of specimens of human origin, including blood, wounds, ulcers, pus, throat swabs, urine, bile, and feces of persons with diarrheal disease, as well as from normal stools (Lennette, et al., 1974); however, the organism is isolated from feces of normal individuals only infrequently, and then only in low numbers (Cabelli, 1977). Cases of dysentery caused by A. hydrophila have been documented (Annapurna and Sanyal, 1977) [See Section B.1.a]. Dysentery caused by Aeromonas-like organisms may also be due to Plesiomonas shigelloides (formerly Aeromonas shigelloides). The genus Plesiomonas, and its single species, P. shigelloides was created for those organisms resembling Aeromonas, but lacking some essential features of the genus. This includes the possession of a restricted carbohydrate metabolism and the absence of the enzymes diastase, DNase, lipases, and proteinases. Also P. shigelloides has multiple polar flagella grouped into a tuft, rather than possessing a single flagellum (Buchanan and Gibbons, 1974; Lennette et al., 1974). P. shigelloides has been isolated from the

feces of humans and other mammals, and was responsible for causing two known outbreaks of acute infectious gastroenteritis. It has also been found in association with Shigella in persons with dysentery; in fact, some strains of P. shigellioides possess an O-antigen identical to Shigella sonnei (Buchanan and Gibbons, 1974; Lennette, et al., 1974).

(i) Enumeration Methods. Membrane filtration using DSF medium (Schubert, 1976) is capable of detecting A. hydrophila and A. punctata in drinking water. The multiple tube method employing Rimler-Schotts medium has been extensively used to enumerate A. hydrophila in natural waters (Schotts and Rimler, 1973).

Aeromonas is not fastidious in its growth requirements, and abundant growth occurs on nutrient agar and blood agar. Aeromonas grows on the differential-selective media used for coliform plating, such as eosin-methylene blue (EMB) agar, MacConkey agar, and Salmonella-Shigella (SS) agar, mimicking coliform colonies, and occasionally on brilliant green agar producing colonies resembling Salmonella (Hendricks, 1978; Lennette, et al., 1974; Mack, 1977). The oxidase test is a rapid and easy means to distinguish the Aeromonas colonies from the coliform or Salmonella colonies, and its use is thus of cardinal importance in total coliform detection procedures (Mack, 1977).

(ii) Evaluation as an Indicator. Because A. hydrophila and A. punctata are capable of degrading high molecular weight organic wastes such as starches, lipids, and proteins, their enrichment occurs in waters that have received wastewater additions. Massive multiplication of Aeromonas has been noted to occur even in pipes draining household wastes (Schubert, 1967b).

In raw sewage, it is not uncommon for Aeromonas concentrations to reach  $10^6$  colony-forming units per ml. During primary treatment their numbers are not reduced, but a significant decline in their numbers occurs during secondary treatment, the degree depending on the biological treatment method employed (Schubert, 1967c). Reductions in the numbers of Aeromonas could possibly be used to indicate the extent of pathogen removal during treatment of wastewaters and in the final effluent. It has been shown that the elimination of Aeromonas correlates well with the elimination of Salmonella and other pathogens (Schubert and Schäfer, 1971).

From these and other results, it appears that the enumeration of Aeromonas from treated sewage effluents may be used as an index to determine whether pathogens remain in the wastewater. Its detection from surface waters or groundwaters indicates sewage contamination of that water.

Once introduced into water, Aeromonas may grow on the organic pollutants contained in the wastewater. Growth of Aeromonas has been reported to occur on filters at potable water treatment works as well as in other locations containing sufficient organic material (Hendricks, 1978) [See Sections E.3 and 4]. The detection of high numbers of Aeromonas has been reported to be a reliable indicator of the degree of contamination of a water source with organic wastes (Schubert and Schafer, 1971).

The proportions of aerogenic to anaerogenic subspecies of A. hydrophila may also be used to evaluate the degree of wastewater contamination. Table C.2.h-1 describes the subspecies of the two important Aeromonas species from the standpoints of their aerogenicity and their distributions in raw waters (Buchanan and Gibbons, 1974).

In wastewaters, or in waters containing wastewaters and solid wastes, the Aeromonas population consists almost entirely of the anaerogenic varieties, with very few aerogenic organisms isolated. The reverse is true of good quality surface waters in which Aeromonas densities are low, but of those organisms isolated, 95 to 98 percent are aerogenic (Schubert, 1975b). In groundwaters, aerogenic Aeromonas varieties are found at the surface, whereas the anaerogenic varieties occur in deep or undisturbed areas (Schubert, 1976).

Studies of the water from river bank infiltration wells demonstrates that the proportion of aerogenic aeromonads increases with increasing distance from the point of application, so that as purification of the river water occurs by passage through the soil, the population of Aeromonas shifts from predominately anaerogenic to predominately aerogenic (Schubert, 1976). Thus, the isolation of anaerogenic aeromonads from raw water indicates contamination with inadequately treated wastes.

Aeromonas resembles coliforms in all respects except that it possesses polar flagella and is cytochrome oxidase positive (Buchanan and Gibbons, 1974; Hendricks, 1978; Lennette, et al., 1974). During total coliform isolation,

TABLE C.e.h-1

DISTRIBUTION OF AEROGENIC VERSUS ANAEROGENIC AEROMONAS IN WATER

	<u>A. Hydrophila</u> Subspecies			<u>A. Punctata</u> Subspecies	
	<u>Hydrophila</u>	<u>Anaerogenes</u>	<u>Proteolytica</u>	<u>Punctata</u>	<u>Caviae</u>
Gas produced from:					
glucose	+	-	-	+	-
glycerol	+	-	-	-	-
Isolated from:					
uncontaminated					
water	+	-	ND <sup>a</sup>	+	-
contaminated					
water	-	+	ND	-	+

<sup>a</sup>No data available.

the lactose-positive, aerogenic strains of Aeromonas are also recovered, since the multiple tube test detects gas production. Therefore, the presence of Aeromonas elevates the apparent total coliform concentration (Leclerc, et al., 1977b; Mack, 1977). In the FRG, coliform analysis of drinking waters revealed that 30 percent of the samples having positive presumptive tests also contained Aeromonas (Leclerc, et al., 1977b). Thus, it is essential to distinguish these organisms from coliforms. Unfortunately, Aeromonas differentiation from coliforms is neglected in the current standard procedures for total coliform testing used in the U.S. (Leclerc, et al., 1977b).

(iii) Conclusions. Aeromonas is a saprophytic organism that occurs in both marine and fresh waters. Its presence in raw waters does not signal any significant health hazard; however, these organisms are opportunistic pathogens especially if ingested in large quantities (e.g., after enrichment in foods, although as yet few food-related diseases due to Aeromonas or the closely related Plesiomonas have been reported). High numbers of Aeromonas also are undesirable in bathing waters, for they may act as opportunistic pathogens if they gain entry into the body via a wound.

Because Aeromonas is a potential pathogen, it must be considered undesirable in drinking waters. Aeromonas is generally sensitive to disinfection treatments, so its presence in finished waters indicates inadequate disinfection or subsequent contamination [See Section F.2.a]. As an indicator of finished water quality, Aeromonas detection has no advantages over the detection of total coliforms.

Aeromonas survives in environmental waters considerably longer than E. coli or most coliforms. However, because it is capable of aftergrowth, as is true of some members of the total coliform group, but not of E. coli, Aeromonas detection may falsely signify contamination with sewage. Small numbers of aerogenic Aeromonas are common in groundwater, at the surface, and in contaminated surface waters, so they do not connote any hazard to public health; whereas anaerogenic Aeromonas varieties are predominant in wastewater and their detection indicates contamination of the water with sewage. Because the current Aeromonas enumeration methods do not distinguish aerogenic from anaerogenic varieties, detection of Aeromonas could lead to false condemnation of a raw water.

The aerogenic varieties, although present in smaller quantities than the anaerogenic types, are already being

detected along with total coliforms in the MPN total coliform procedure, and all types are probably isolated when using the membrane filtration procedure. Thus, it seems that the easiest way of determining the presence of Aeromonas would be to do an oxidase test following total coliform isolation. The most important feature of Aeromonas is that its presence may yield inaccurately elevated estimates of coliform densities, so any total coliform detection procedure should also include the oxidase test to determine their presence. Because of its natural occurrence in the environment, potential for aftergrowth in nutrient-enriched water, and confusion with total coliforms, Aeromonas would not be a very specific indicator of sewage discharge or pathogen occurrence; where raw water quality is concerned, Aeromonas should be considered as a general indicator in relation to nutrient discharge.

(iv) Summary. Some members of the genus Aeromonas, particularly A. hydrophila and A. punctata are potential pathogens that are widely distributed in the environment. They thrive in heavily contaminated waters, particularly those derived from kitchen wastes. The anaerogenic varieties are common to contaminated waters, therefore, their presence may be considered an indicator of the degree of organic contamination of raw waters. However, because Aeromonas is capable of aftergrowth in environmental waters, its detection may exaggerate or falsely signal a public health hazard. Because Aeromonas is very sensitive to disinfection, its presence in drinking water is an indication of inadequate treatment or a breakdown in the distribution system. Due to its similarity with the total coliforms, Aeromonas, if present, will be detected along with them and may even constitute a significant proportion of the detected total coliforms. The extent to which this occurs may be determined with the aid of the oxidase test.

If for some reason, drinking water is to be used without disinfection, aerogenic Aeromonas may cause false positive results in both the multiple tube and membrane filter total coliform tests with water that is not unsafe. Anaerogenic Aeromonas seen in the membrane filter coliform test with such samples would, in fact, signal a hazard. No Aeromonas should be present in finished drinking water that has been disinfected, so both false (due to Aeromonas) and true positive results in the total coliform test are significant with such samples. In a sense, the presence of Aeromonas augments the sensitivity of the total coliform test for finished drinking water.

### 3. Other Indicators of Microbial Quality

Three relatively new biochemical methods have been employed to determine water quality. They do not measure microbial numbers directly, as do the indicator systems presented in the previous two sections. Instead, microbial numbers are determined indirectly in the case of Limulus lysate and adenosine triphosphate; these tests for fecal sterols serve as a chemical index of fecal pollution. Although these methods certainly must be measured against the more traditional microbiological indicator systems, their validity as indicators ultimately must be decided on the basis of their own merits.

a. Limulus Amebocyte Lysate. Limulus amebocyte lysate (LAL) is an aqueous extract of blood cells (amebocytes) from the horseshoe crab, Limulus polyphemus (Levin and Bang, 1969). LAL forms a clot or becomes turbid when incubated with lipopolysaccharides (LPS), also known as endotoxins, which are components of the cell wall of all gram-negative bacteria.

An elevated LPS or bacterial biomass concentration in a water sample does not, by itself, constitute a health hazard to a normal, healthy human. However, an elevated LPS or bacterial biomass level indicates contamination of a water source by gram-negative bacteria and in certain areas, for example, near sewage outfalls, may indicate the presence of potentially pathogenic bacteria (Evans, et al., 1978) [See also Sections A.1.f and B.1.a(ix)]. LAL currently is used to detect and quantitate endotoxins in a variety of solutions by a technique commonly referred to as the LAL or LPS test (Watson, et al., 1977).

The LPS test has been modified for use in determining bacterial biomass in aquatic environments (Watson, et al., 1977). The concentration of LPS in a sample is measured before and after centrifugation at 10,000 x g. The level of LPS that is free (in the supernatant after centrifugation) is subtracted from the total LPS (in the sample before centrifugation) to determine how much LPS was bound to cells. Finally, the bacterial biomass is obtained by multiplying the concentration of bound LPS by a factor of 6.35 (Watson, et al., 1977) to obtain the grams of bacterial cellular carbon in a given volume of water.

(i) Methods of Reading the LPS Test. The LPS test can be read either by a clot or a spectrophotometric method.



With the clot method, 0.1 ml of the sample is added to 0.1 ml of the LAL and incubated for 1 h at 37°C. If a firm clot is formed after incubation, the test is considered positive. This can be applied as a quantitative test by reacting an LPS standard, prepared in twofold serial dilutions, with LAL. The endpoint of the test is the lowest LPS concentration that will trigger clot formation of LAL. Appropriate twofold dilutions of the water sample also are made and reacted with LAL. The highest dilution in which clotting occurs is multiplied by the sensitivity of the LAL to obtain the LPS equivalents in the test water, expressed as ng per ml.

The clot method is easy to perform and requires minimum operator skill. However, it does not allow for exact quantitation of LPS in a water sample; instead, this can be done using a spectrophotometer by the method of Watson and coworkers (1977). In this method, 0.2 ml of LAL is added to a 1.0-ml portion of the sample. For freshwater samples, dilutions should be made with pyrogen-free distilled water, whereas seawater dilutions are made with a 3 percent pyrogen-free sodium chloride solution. After incubation for 1 h at 37°C, the samples are gently mixed by rotary agitation and the absorbance of each read in a spectrophotometer at 360 nm.

A standard curve is generated by incubating LAL with known concentrations of LPS in a dilution series that can range from 0.1 to 100 pg per ml. The limits of the range vary according to the sensitivity and range of linearity of the particular LAL preparation used. The concentration of LPS can then be determined by making serial dilutions of the sample and reacting these with LAL. LPS concentrations in samples are determined by comparing their absorbance readings with those found in the linear region of the standard curve.

(ii) Evaluation of the LPS Test as an Indicator of Water Quality. Some studies have demonstrated the presence of LPS in raw and finished water. DiLuzio and Friedman (1973) detected LPS in 16 of 18 finished water samples using an insensitive assay with a detection limit of 10 ug per ml (the two negative drinking water samples came from artesian wells). When the positive samples were measured for endotoxin content by taking serial dilutions, they were found to contain LPS levels of between 1 and 10 ug per ml. Raw surface water, used as a drinking water source, was tested

in the same study and found to have LPS levels of 20 to 400 ug per ml. In other studies (S. Watson, unpublished results), LPS levels of between 1 and 10 ng per ml were found in finished water of Woods Hole (Massachusetts, U.S.).

A number of samples of drinking water and renovated wastewater from advanced wastewater treatment plants was analyzed by Jorgensen and coworkers (1976). Drinking water, sampled from ten cities in the U.S., had LPS concentrations ranging from < 0.625 to 500 ng per ml. When the processes employed by the water treatment plants were examined, no association was found between use of activated charcoal and high endotoxin levels. But, high LPS levels were found in the effluents of five out of eight advanced wastewater treatment plants surveyed, and positive results did correspond with those plants that treated with activated carbon [See Section E.5]. One of the other three wastewater treatment plants, in which only low endotoxin levels were revealed, also used activated carbon, but followed it with breakpoint chlorination [See also Sections E.2 and F.2.a]. One plant, which employed a reverse osmosis unit as the final treatment step, produced water containing no detectable LPS. As more and more water is being reclaimed due to limited water resources in the world, application of advanced wastewater treatment for producing potable water will increase.

Evans and coworkers (1978) used a spectrophotometric assay with tapwater and found the sample to contain 1.19 ng per ml of LPS, of which 1.10 ng per ml was free LPS and 0.09 ng per ml was bound or cell-associated LPS. They also used this assay with several environmental samples to determine the correlation between endotoxin levels and bacteriological parameters. The correlation coefficients between bound LPS and the other parameters were: coliform (0.907), enteric bacteria (0.946), gram-negative bacteria (0.934) and heterotrophic bacteria (0.952) [See also Sections C.1.a to c and D]. Whether all environmental water exhibits this high correlation, and whether the same holds true for drinking water, has not been established.

(iii) Potential Applications of the LPS Method. The LPS method could be applied in long-term routine monitoring and also as an emergency method to determine whether there has been an increase or decrease in gram-negative bacteria in raw or finished water. Another application for which this test may be particularly well suited pertains to the

increased use of granular and powdered activated carbon in the treatment of drinking water to remove organic compounds. Since bacteria are likely to grow on the adsorbed organic material, the LPS assay could prove useful for monitoring bacterial growth [See Project Area II.b]. Likewise, this assay could serve as a fast and simple method for determining, periodically, the LPS or bacterial levels in home point-of-use water treatment devices, such as activated carbon and reverse osmosis units [See Section G.2]. Even though these devices are known to eventually foster bacterial growth if not properly maintained (Wallis, et al., 1974), their use in the home has increased. Commercially available LAL kits could easily be adapted to serve as convenient household monitors.

The endotoxin assay will not replace coliform and colony counts or other methods routinely used to survey bacterial populations in municipal water supplies [See Sections C.1.a to c]. However, it could serve as a fast and convenient additional technique for measuring parameters related to public health [See also Section C.4.g]. The values could be used to indicate long-term trends, reveal differences from city to city, or rapidly determine sources of contamination in emergency situations, even in the field, if necessary.

(iv) Summary. The LAL or LPS assay for LPS quantitation is fast, accurate, and inexpensive. LPS, a component of the cell wall of all gram-negative bacteria, is of potential harm to humans and other animals only after entering the bloodstream. However, the LPS concentration in a volume of water is directly related to the level of gram-negative bacteria contained in that water. Thus, the LPS test has considerable potential for use in monitoring raw and finished water for the presence of gram-negative bacteria or endotoxin, including assessing bacterial contamination due to growth on activated carbon filters. It also could be of great assistance in evaluating the efficacy of advanced wastewater treatment employed as a means of producing potable water.

b. Adenosine Triphosphate. There have been many attempts to quantify cellular components in an effort to estimate cell numbers and, in this manner, to develop a nonspecific, quantitative indicator of biota in drinking water. Most of these attempts have been less than successful because of the difficult problem of distinguishing among

compounds present in viable, active cells and those present in dead cells or detrital material. Adenosine-5'-triphosphate (ATP) is a compound which, to a large extent, circumvents this problem. ATP shows good potential as a non-specific indicator of viable organisms in drinking water because it is: (1) present in all living cells; (2) rapidly hydrolyzed by cellular enzymes upon cell rupture or death; and (3) relatively constant in proportion to the biomass of many studied organisms.

A figure of 0.4 percent of total carbon is usually applied when determining the ATP content of a cell; hence, the total carbon is estimated as 250 times the ATP mass. Although this represents a moderate concentration within the organism, direct chemical analysis of ATP is not usually possible because the numbers of organisms most often encountered in drinking water are low.

The most commonly used method to determine ATP levels is the firefly luciferin-luciferase assay. ATP is extracted from the cells and reacted with firefly lantern luciferin and luciferase, in the presence of magnesium ions and at the proper pH (which depends on the extractant used). This reaction results in the production of light and may be shown as follows:

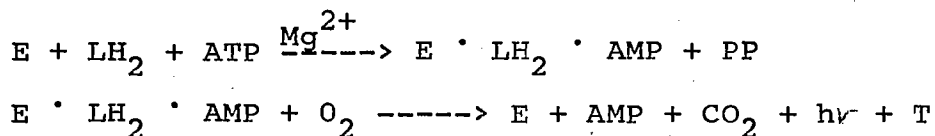

where E is the enzyme luciferase,  $LH_2$  is reduced luciferin, AMP is adenosine-5'-monophosphate, PP is pyrophosphate,  $h\nu$  is light, T is thiazolinone (which is decarboxylated reduced luciferin). The light emitted when ATP is injected into the enzyme reaction mixture rises in intensity quickly and then decays exponentially. Both the maximum intensity, measured as peak intensity, and the total light output are proportional to the amount of ATP added, as long as it falls within a range of  $1 \times 10^{-9}$  to  $2 \times 10^{-2}$  g per l.

(i) Methods for extracting and quantifying ATP. When testing environmental samples, extracting ATP from microorganisms and stabilizing it can become more difficult. Not only can the growth rate and physiological state of cells from various sources affect the content per cell of ATP, but also the extraction process itself may alter final ATP readings.

The extractant must be capable of immediately inactivating intracellular and extracellular ATPases and phosphatases, which can otherwise decrease the ATP concentration within a few seconds (Tobin, et al., 1978). It must also be capable of efficiently extracting the ATP from the large variety of cells which may be encountered. Both organic materials (such as humic substances) and inorganic cations often associated with drinking water (such as  $\text{Ca}^{++}$ ,  $\text{Mg}^{++}$ ,  $\text{Al}^{+++}$ ,  $\text{Fe}^{++}$  and  $\text{Mn}^{++}$ ) may interfere to varying degrees, depending on the method of extraction used. A judicious choice of extractants will usually prevent such interference (Tobin, et al., 1978).

Extractants include tris-(hydroxy methyl)-aminomethane (Tris) buffer, sulfuric acid, nitric acid, dimethyl sulfoxide, glycine buffer, phosphate buffer, and many others. Of the most commonly used extractants, boiling alkaline (pH 10) glycine buffer, containing magnesium-ethylene-diamine-tetraacetate, offered the most efficient combination of extracting ATP (in the presence of organic and inorganic constituents) and stabilizing it (Tobin, et al., 1978). When automated systems were employed to concentrate the sample and extract ATP, the use of nitric acid afforded adequate stabilization (Picciolo, 1977; 1978). The most common extractant currently in use for environmental samples is boiling Tris buffer (American Public Health Assoc., 1976). It is the basis of one of the original extraction techniques (Holm-Hansen and Booth, 1966), and one on which much of the ATP data is based.

The enzyme reaction and apparatus for detecting and measuring luminescence have been fairly well established. Several types of photometric equipment are commercially available which quantify ATP by integrating the light output over a period of less than 1 min, or by determining the peak light output during the first few seconds of the reaction, or both. Other equipment, such as liquid scintillation counters, fluorometers, and reaction-rate analyzers may also be used to quantify the light output.

Perhaps the greatest problem with using the bioluminescent method for determining ATP levels in drinking water is the need to concentrate the sample sufficiently. The linear range of ATP detection for a typical photometer is down to about  $10^{-12}$  g ATP under ideal sample conditions. The average bacterium has been variously estimated to contain  $3 \times 10^{-16}$  g ATP (Picciolo, et al., 1977a), or from 2 to 40  $\times 10^{-16}$  g ATP, depending upon growth phase (Hamilton and Holm-Hansen, 1967). If the value of  $3 \times 10^{-16}$  g ATP per cell is

used, it can be calculated that a minimum of  $3 \times 10^3$  cells would be required to evoke a quantitative response under ideal conditions. If the maximum acceptable level is 500 cells per ml of finished water, then it is necessary to make estimates based on this critical quantity, and therefore concentration of the sample usually is required.

A recent report (Picciolo, *et al.*, 1978) compared several methods of concentration which included centrifugation; in-line membrane filtration; radial- and tangential-flow, flat-surface membrane concentration; and hollow fiber membrane filtration. Only the hollow fiber membrane filtration procedure (modified for backwashing) provided adequate concentration and recoveries. A commercially available unit, with a filter area of  $10^4$  cm, was capable of concentrating the sample 600-fold with up to 88 percent recovery after backwashing steps had been performed. This unit offers good potential for determining levels of bacteria which one may find in tapwater. Unfortunately, the method has yet to be tested extensively on actual tapwater.

(ii) Evaluation of ATP as an Indicator. Few studies have as yet been performed on finished water, and more often pertinent data obtained from raw water studies are used for drinking water analyses. One study has been reported briefly (Rexing, 1977) in which the luciferase ATP method was used to replace the tedious microscopic counting of algae, and to verify chlorination efficiency on drinking water. Raw water was filtered through a 3.0  $\mu$ m membrane filter which was then submerged in boiling Tris buffer. ATP levels were usually about  $10^{-7}$  g per l and increased to about  $10^{-6}$  g per l during a *Cyclotella* bloom. It was demonstrated that most of the algae which passed through the treatment system were killed and were, therefore, not positive for ATP; in this instance, then, the method was not suitable for monitoring total algal counts in finished water. A free chlorine residual of 1.6 mg per l caused at least a 99 percent decrease in the biomass, as measured by the luciferase ATP method. Surface water of Lake Ontario was shown, in a limited study (Afghan, *et al.*, 1977), to harbor an average of  $5 \times 10^{-5}$  g ATP per l.

Although no extensive studies have been made of the ATP content of drinking water, some comparisons between bacterial estimates calculated from a model plate count system, and those from an ATP system, have been made (Picciolo, *et al.*, 1977a). In this study, *E. coli* cultures were diluted in

0.9 percent NaCl or dechlorinated tapwater. The results were linear from  $10^5$  to  $10^9$  bacteria per ml by both methods, and the ratio between plate counts and counts estimated by ATP content did not differ from 1 at the 5 percent confidence level. However, when treated effluents from a pilot sewage treatment plant were analyzed, the luciferase-measured ATP indicated bacterial levels of 1.8 times the number obtained by viable plate counts. This was likely attributable to residual ATP in viable cells which were debilitated to the point of being unable to undergo cell division under the culture conditions used.

A limited study on the ATP content of a municipal tapwater in Canada (J. Cairns, unpublished data) showed  $11 \times 10^{-9}$  g per l (range of five values was  $5.3 \times 10^{-9}$  to  $16 \times 10^{-9}$  g per l) and after passing through a 0.6  $\mu$ m polycarbonate (Nuclepore) filter, the ATP content was reduced to  $3.7 \times 10^{-9}$  per l (range was  $2.5 \times 10^{-9}$  to  $6.3 \times 10^{-9}$  g per l). While this would indicate the potential of about  $10^4$  bacteria per ml, it has been shown that chlorine-stressed coliforms, thermo-tolerant coliforms, and total heterotrophic bacteria are much more reduced in ability to grow on their respective media than the decrease in ATP would indicate (Cairns, *et al.*, 1979). Thus, it is improbable that this number of bacteria would be found by standard colony counts.

These results point out a problem which has yet to be resolved: that is, the effect of stress on the ATP content of organisms and on their ability to divide. It appears that in some stress situations, organisms lose their ability to divide, and the ATP decreases to a minimum level which may be a maintenance or survival value (Dawe and Penrose, 1978). A systematic study should be made of the effects of chlorine on the total microbial population in water, so that the interpretation of data will more closely reflect actual conditions.

(iii) Potential Applications of the ATP Method. The luciferin-luciferase assay has been shown to be a reliable nonspecific method for the analysis of the viable bacteria in water. Because of its potential to enumerate microorganisms in water, it may become useful in supplementing total plate counts in water, especially when applied as an on-line system to signal any changes in water quality at a water treatment plant. It may also be employed during emergencies when the rapid analysis of samples is required,

for example, in the event of disruption of a water main or gross bacteriologic contamination of samples.

Presently, the major problem with the ATP assay is the requirement for concentration in order to quantify the bacteria in water. Progress in this area has been made with the use of hollow fiber filters, which should enable the technique to be used routinely in the near future. A system of semi-automatic filtration and analysis, both in one apparatus (Picciolo, *et al.*, 1977b), would seem to lead the way to rapid and accurate determinations. Some studies have been initiated on the use of immobilized enzymes in the performance of the ATP assay (Lee, *et al.*, 1977). The use of immobilized enzymes may increase the potential for automation and economy of reagents.

The combination of flow concentration and immobilized enzyme reactors in close proximity to phototubes could significantly increase the number of samples processed and lower the cost per assay. It may be possible to have an automated sampling system which monitors raw water input and finished water output, and which alerts the waterworks operator to any unusual changes in values for either of the two. Long-range trends in the quality of water should be monitored closely by the use of retrospective data analyses, and any trends noted in the deterioration of water quality should evoke appropriate corrective steps.

(iv) Summary. ATP is a compound present in all living cells and is degraded rapidly upon cell death. The luciferin-luciferase assay for ATP can be used for analyzing the approximate numbers of microorganisms in water. The reaction is valid between about  $10^3$  to  $10^7$  bacterial cells and generally requires large concentration factors for the low densities of bacteria encountered in drinking water. Concentration can be achieved by means of hollow fiber filters to about 600 times with up to 88 percent recoveries. The principal applications of the ATP analysis are in monitoring algal content and removal in raw water, and in determining total bacterial numbers and disinfection efficiencies in finished water. Other potential uses are analyzing samples during main breaks and monitoring long-term changes in treatment and in the distribution system.

c. Fecal Sterols. Coprostanol or coprosterol (5 $\beta$ -cholestan-3 $\alpha$ -ol) is the major fecal sterol of man, comprising



40 - 60 percent of the total neutral sterols excreted. Studies to date, identifying it in sewage and surface waters, have lent support to proposals that it be considered for use as a fecal marker of water pollution -- especially pollution of the type associated with industrial or wastewater treated discharges (Murtaugh and Bunch, 1967; Smith, et al., 1968; Smith and Gouron, 1969; Kirchmer, 1971; Tabak, et al., 1972; Dutka, et al., 1974; and Wun, et al., 1976). If coprostanol were confirmed to originate only in the feces of man and higher animals, as is generally believed the case, then it would be a highly specific chemical indicator. And, being a chemical indicator, coprostanol analysis would have the advantage over bacterial indicators of requiring less preparation and processing time. Furthermore, various purification processes applied to drinking water or simple passage through soil in the case of groundwater, can remove fecal organisms without removing some of the associated fecal material. Testing for coprostanol could be useful in this regard, especially in connection with drinking water analyses. However, more definitive information is needed before coprostanol analysis of water quality could be performed routinely.

(i) Cholesterol Reduction to Coprostanol. The reduction of cholesterol to coprostanol and the various factors affecting such a transformation in biological systems have been studied by many workers. Earlier investigations have been documented in several reports (Gould and Cook, 1958; Hoffman, 1970; Kirchmer, 1971). It has been shown that the hydrogenation of cholesterol to coprostanol is mediated by microorganisms in the large intestine of man and higher animals. Apparently, this is the only source of the  $5\beta$ -stanol. Recently, an anaerobic gram-positive eubacterium, having an absolute requirement for  $\Delta^3-3\beta$ -hydroxy steroids, was isolated from human feces and from rat intestinal contents (Eyssen, et al., 1973; and Sadzikowski, et al., 1977). This diplobacillus reduced the 5, 6-double bond of cholesterol, campesterol,  $\beta$ -sitosterol, and stigmasterol, yielding the corresponding  $5\beta$ -saturated derivatives. When cholestanone (4-cholesten-3-one) and coprostanone were incubated with this organism, the carbonyl and the 3-oxo groups of these molecules were reduced to a  $3\beta$ -hydroxyl group (Eyssen, et al., 1973). Using dual labeled cholesterol as a tracer, Parmentier and Eyssen (1974) concluded that the major pathway for the conversion of cholesterol to coprostanol in the animal intestine involved the intermediate formation of 4-cholesten-3-one followed by a reduction.

(ii) Coprostanol Removal During Sewage Treatment. A wastewater plant which employs an activated sludge process will produce an effluent low in or free of coprostanol (Murtaugh and Bunch, 1967; Smith, et al., 1968; and Smith and Gouron, 1969). This removal was believed to be mainly physical (Smith, et al., 1968). However, by comparing coprostanol degradation rates in chlorinated versus unchlorinated sewage effluent, Kirchmer (1971) concluded that coprostanol removal by the activated sludge process was due principally to biodegradation. C. K. Wun and coworkers (unpublished data) detected unusually high levels of coprostanol in the activated sludge. They found coprostanol breakdown to occur at a much slower rate when sewage was combined with sterilized (membrane-filtered) fresh water and seawater than when combined with unsterilized (unfiltered) water. It is likely that both physical and biological processes are at work removing coprostanol during activated sludge treatment.

(iii) Environmental Effects on Coprostanol Degradation. The rate of coprostanol ester degradation is essentially the same as that of free coprostanol. Coprostanol esters are present in large amounts in feces (approximately 30 percent of the total coprostanol), and the ratio of the steryl esters to the total sterols was found to be 10 - 15 percent in sewage samples (Kirchmer, 1971). Using radioisotope labeled coprostanol palmitate, Wun, Walker, and Litsky (unpublished data) found that the ester bond was rapidly hydrolyzed resulting in 80 percent degradation during one to three days of any environmental exposure. This rapid hydrolysis may occur under aerobic conditions in the sewer system prior to the treatment plant, and may account for the low ratio of steryl esters to sterols found in raw sewage samples.

(iv) Agreement between Coprostanol and Other Accepted Criteria. In an attempt to establish fecal sterol criteria and standards, efforts have been made to correlate coprostanol concentrations with other accepted water quality standards. Tabak and coworkers (1972) reported that coprostanol concentrations in non-chlorinated polluted water correlated well with fecal coliform densities in the same locations. Other investigators obtained contrasting results (Kirchmer, 1971; Dutka, et al., 1974; Dutka and El-Shaarawi, 1975; and Wun, et al., 1976). Kirchmer (1971) postulated that fluctuations in bacterial populations (from chlorination and from additional coliforms released in waterfowl feces) might explain why no clear relation could be shown

between coprostanol and bacterial densities. Singley and coworkers (1974) reported a linear relationship with a coefficient of determination ( $r^2$ ) of 0.977 between coprostanol and total organic carbon (TOC) in sewage samples. Results of correlating the coprostanol concentration with biochemical oxygen demand (BOD) and chemical oxygen demand (COD) were less satisfactory.

(v) Significance of Coprostanol in Water. The unique characteristics of coprostanol recommend its use as a chemical index for water quality determination. It appears that the only source of this chemical is the feces of man and higher animals. It is biodegradable and can be removed from sewage by adequate treatment. Studies have also shown that coprostanol concentrations correlate closely with the extent of fecal pollution (Murtaugh and Bunch, 1967; Smith and Gouron, 1969; Kirchmer, 1971; Tabak, *et al.*, 1972; and Wun, *et al.*, 1976). Coprostanol, as opposed to coliforms, remained unaffected by wastewater chlorination, heat, and toxic industrial discharges; hence, coprostanol quantitation was seen to overcome many flaws inherent to coliform analyses (Kirchmer, 1971; and Tabak, *et al.*, 1972). The relative stability of coprostanol is especially significant in view of current trends of rapid industrial development and the increasing emphasis on disinfection of raw and treated wastewater.

Because of its tolerance of environmental rigors, coprostanol might also be used for monitoring the source, course, and extent of fecal pollution in the ocean or brackish waters where bacteriological evidence is often doubtful. It also offers promise as a method for analyzing the distribution and mixing dynamics which occur when, for example, sewage effluent enters river water, or when sewage polluted surface water infiltrates into groundwater. Examinations of water that reveal the presence of fecal sterols, but no fecal bacteria, still indicate fecal pollution. Conversely, when indicator bacteria are present, but fecal sterols are not detected, this may indicate bacterial regrowth or infiltration, rather than fecal pollution, although degradation of the sterols must also be considered.

(vi) Coprostanol Analysis. The routine procedure for estimating coprostanol levels in water consists of hexane extraction, clean-up by thin layer chromatography (TLC), and

subsequent analysis by gas-liquid chromatography (GLC) (Murtaugh and Bunch, 1967; Smith, et al., 1968; Smith and Gouron, 1969; Kirchmer, 1971; Tabak, et al., 1972). The TLC clean-up procedure has been considered necessary for all surface water samples regardless of concentration (Murtaugh and Bunch, 1967; and Tabak, et al., 1972). However, processing samples through an alumina micro-column affords a more efficient clean-up procedure (Dutka, et al., 1974). The TLC clean-up can also be omitted if a sample containing > 1 ug of coprostanol per l is washed instead with acetonitrile saturated with hexane (Kirchmer, 1971).

In earlier studies of coprostanol quantitation, analysis included mild alkaline hydrolysis and/or preparation of trimethylsilyl ether derivatives (Murtaugh and Bunch, 1967; Tabak, et al., 1972). Results reported by Kirchmer (1971) suggest that omission of these time-consuming processes does not significantly affect coprostanol identification and quantitation. Later findings led to elimination of the saponification step, resulting in analysis of only the free sterol (Dutka, et al., 1974; Wun, et al., 1976; 1978).

Although the hexane liquid/liquid partitioning procedure was satisfactory for coprostanol extraction, it required an excess of reagents and was often further complicated by emulsion problems (Murtaugh and Bunch, 1967). In addition, much of the coprostanol present in heavily polluted areas is bound to particulate matter (Kirchmer, 1971; Wun, et al., 1978). Switzer-House and Dutka (1977; 1978) have shown that, in most samples, > 70 percent of the fecal sterols are associated with the pellet after centrifugation. Hexane's immiscibility with water may protect the fecal sterols, trapped within aggregates, from contact with the solvent. Under such circumstances, fecal sterols are unlikely to be extracted completely (Wun, et al., 1978). A column method has been developed which employs XAD-2 polystyrene polymeric resin for extracting coprostanol from water (Wun, et al., 1976; 1978). This method has been shown to be effective and avoids the excessive use of chemicals. However, adsorption and desorption are pH-dependent; the solvent must be dried repeatedly due to traces of water in the acetone eluate. Recently, the column technique has been improved by using XAD-1 non-ionic resin -- chemically similar to, but more porous than, XAD-2. Results indicate that XAD-1 resin eliminates the need for adjusting pH. Rapid drying of the eluate may be accomplished by means of a basic methanol

partial clean-up step added to the new column procedure. This entails displacing water in the column with methanol prior to elution (Wun, Rho, Walker, and Litsky, unpublished data). The use of benzene during elution, however, is undesirable for routine testing and a more acceptable solvent to remove the fecal sterols from the resin is now being sought.

(vii) Comparison of Coprostanol, Cholesterol, and Coprostanone as Indicators. Three of the neutral steroids found in the feces of man and higher animals -- namely, cholesterol (5-cholestan-3 $\beta$ -ol), coprostanol (5 $\beta$ -cholestan-3 $\beta$ -ol), and coprostanone (5 $\beta$ -cholestan-3-one) -- have been suggested as potentially useful chemical indicators of fecal pollution in water (Murtaugh and Bunch, 1967; Smith, et al., 1968; Tan, et al., 1970; and Dutka, et al., 1974). Although cholesterol constitutes a major component of the fecal sterols, it is also present in eggs, milk, lard, and wool grease (Murtaugh and Bunch, 1967). Except in specific instances, this sterol does not specifically indicate fecal pollution. In addition, cholesterol seems to be widely distributed at its limit of solubility in seawater (Smith and Gouron, 1969). Coprostanone, on the other hand, is usually a minor component of feces, being present at about one-tenth the concentration of coprostanol. It was suggested that coprostanol may be readily oxidized to coprostanone in the environment and that this ketone is, in effect, a more stable chemical indicator (Dougan and Tan, 1973). However, environmental contaminants interfered less in the detection, by means of gas liquid chromatography, of coprostanol, rather than coprostanone (Wun, Walker, and Litsky, unpublished data).

(viii) Conclusion. Coprostanol satisfies the generally accepted criteria for a good indicator of fecal pollution. To employ this fecal sterol for the practical assessment of water quality, however, more work is needed. Although this chemical appears to originate from the intestine of man and higher animals, it has been found to occur in the feces of chickens and in tissues of other animals (Kirchmer, 1971); also, seaworms obtained from sewage-polluted seawater may excrete large amounts of coprostanol in their feces (Wun, Walker, and Litsky, unpublished data). High concentrations of coprostanol have been shown to absorb onto sewage particulates, as do viruses. Hence, it is likely that by ingesting

and concentrating these contaminated particulates, various aquatic organisms have been responsible for the high levels encountered. Whether lower animals concentrate coprostanol exclusively by ingestion, or whether they also harbor microorganisms which can transform cholesterol to coprostanol, remains to be learned. Two procedures, hexane liquid/liquid partitioning and polystyrene polymeric resin column extraction, are presently available for coprostanol isolation from waters. Gas-liquid chromatography is commonly used for quantifying this fecal sterol.

Coprostanol is biodegradable; nonetheless, Dutka and coworkers (1974) recovered high concentrations of this sterol at a substantial distance from fecal sources, suggesting a possible resistance to biodegradation. More studies are needed to determine how coprostanol is degraded and how various environmental factors affect decomposition rates. Also needed are studies to ascertain coprostanol persistence and baseline levels in surface waters and in sediments.

(ix) Summary. Coprostanol is the major fecal sterol of humans, comprising 40 to 60 percent of the total neutral sterols excreted. This compound can be concentrated from water and quantified by gas-liquid chromatography in a relatively short time. It is considered a good indicator of fecal pollution because it can be biodegraded during adequate sewage treatment, but is unaffected by chlorination, heat, and toxic industrial discharges; hence it overcomes some inherent problems of conventional bacterial indicators. Further testing of this method is required to obtain more baseline levels in the environment and to ascertain the factors affecting coprostanol persistence.

#### 4. Potentials for Mechanization, Automation, and Shorter Read-Out Times

As water becomes increasingly more subject to reclamation and pollution, and owing to the limited resources available for microbiologic analyses of water, the direction taken in analytic procedures inevitably will be toward large-scale economies. Some of the more successful of these approaches are those that automate, simplify, or otherwise modify the methodology to enable the work to be more precise and accurate, and the results to be obtained more quickly. Increasing the productivity of a method often means that more samples can be taken, thus, increasing the degree of

certainty of results. The methods presented here range from improved versions of established methods to completely new approaches to water microbiology.

a. Radioactive Isotope Methods. Methods in chemistry, especially clinical biochemistry, have evolved rapidly during the last 20 years. Autoanalyzers as well as chromatographic and electrophoretic equipment have become an integral part of most diagnostic laboratories, enabling rapid and accurate chemical analyses. Radioimmunoassay has become an essential, sensitive tool for diagnosing various viral diseases and assaying simple molecules, including hormones.

However, progress in microbiology over the past 30 years has been slow. Diagnostic procedures have not changed significantly. Most of the conventional methods are based on the physiological properties of the various bacterial strains, especially their ability to ferment certain carbohydrates or to metabolize specific amino acids. The sanitary quality of drinking water is still usually determined by counting coliform bacteria, which serve as indicators of fecal contamination [See Sections C.1.b to c].

Methods currently practiced in some countries, for detecting coliforms, entail membrane filtration followed by the fermentation of carbon sources such as lactose [See Sections D.2 and 4]. Biochemical changes become apparent only after a prolonged (minimum 24 to 48 h) incubation to permit the growth of large numbers of the  $3$  indicator (it takes  $1.7 \times 10^3$  coliforms to produce 1 mm<sup>3</sup> of gas -- Levin, 1963). Thus, contaminated samples of drinking water may already have been consumed before public health officials are apprised of the danger and can institute corrective action. More rapid coliform detection methods are needed so that, ideally, bacteriological results would be obtainable within 6 h or less. There is also a need for semi- or fully-automated systems for rapid on-line coliform detection in water treatment plants or at strategic monitoring points in the distribution system [See also Sections C.4.c to g].

Radioactive isotopes have been used, extensively, to study biochemical changes, including bacterial fermentations. These techniques are much more sensitive than the conventional bacteriological procedures; therefore, it is not surprising that labeling compounds with  $^{14}\text{C}$  to help detect, quantify, or identify contamination indicators was

first proposed more than twenty years ago. Unfortunately, despite its merits, this approach has not received the attention which it deserves and is not widely employed for routine microbiological monitoring. There are two applicable radioactive isotope methods, one based on fermentation; the other, based on isotope incorporation.

(i) Fermentation Method. This approach makes use of known biochemical properties of the various bacterial strains. Levin and coworkers (1956) used  $^{14}\text{C}$ -labeled lactose broth to utilize the coliform's ability to metabolize lactose, unlike soil organisms which show no  $\beta$ -galactosidase activity. They reported that this method gave presumptive evidence of coliforms in water in 1 h. Other carbon sources including [ $^{14}\text{C}$ ]glucose and [ $^{14}\text{C}$ ]sodium formate have also been tried, but since these reactions lack specificity, they cannot be used to identify or quantify coliforms.

The sensitivity of the assay can be markedly increased by including additional nutrients in the medium, thereby enhancing bacterial multiplication which in turn contributes to the fermentation process. As in the standard procedures, inhibitors can be added to the isotope-containing medium, rendering it selective. Thus, adding bile salts prevents the growth of soil bacteria but permits that of coliforms. In addition, raising the temperature from 37 to 42°C (as has been suggested) increases the uptake of labeled carbohydrate, along with other enzymatic reactions, thereby accelerating  $^{14}\text{CO}_2$  production.

The radioisotope procedure was modified further with the introduction of membrane filters for concentrating bacteria in large volumes of water. This modification permitted the detection of two to ten coliforms within 6 h (Bachrach and Bachrach, 1974; Reasoner and Geldreich, 1978). The radioisotope procedure has limitations, however, in that it does not permit the exact quantitation of an indicator. The rate at which coliforms ferment carbohydrates may be affected by their previous environmental exposure or handling. Starvation, lack of nutrients, or toxicity of membrane filters may decrease the initial rate of  $^{14}\text{CO}_2$  release, producing a nonlinear  $^{14}\text{CO}_2$  curve when [ $^{14}\text{C}$ ]lactose is the carbon source. This may result from a lag in the induction of  $\beta$ -galactosidase production [See also Section C.4.g].



(i.1) Detection Techniques. Two techniques for collecting and measuring radioactive  $^{14}\text{CO}_2$  are: (1) trapping  $^{14}\text{CO}_2$  on filter papers or by hyamine injection, and counting with a Geiger-Muller or a scintillation counter; and (2) continuous monitoring of the  $^{14}\text{CO}_2$  by flushing the cultures with gas, and counting with an analogue recorder connected to an ionization chamber (Deland and Wagner, 1969).

(i.1.1) Trapping  $^{14}\text{CO}_2$ . Various means have been employed to trap the released  $^{14}\text{CO}_2$ . The reaction is usually carried out in a sealed test tube or container which is shaken in a water bath. Filter papers containing either barium hydroxide (Levin, 1963) or potassium hydroxide are attached to the lid of this container. The reaction is usually stopped by injecting acid, which also releases the radioactive  $\text{CO}_2$  trapped in the solution (in the form of carbonate when the pH of the medium is high). The filter papers containing the radioactive  $\text{CO}_2$  are then transferred to scintillation vials and assayed for radioactivity by liquid scintillation spectrometry (Bachrach, and Bachrach, 1974), or dried and counted with a Geiger-Muller counter.

An alternative method, which may be more precise, uses rubber stoppers to support center wells (K-882320, Kontes Glass Co., Vineland, New Jersey, U.S.) into which hyamine is injected (Bachrach and Bachrach, 1974). The reaction is stopped in the same manner as above, and the center wells are transferred to scintillation vials and counted. In principle, this radioisotope technique can be modified to monitor potable water quality automatically, as suggested by Pijck and Defalque (1963) and Reasoner and Geldreich (1978).

(i.1.2) Continuous Monitoring of  $^{14}\text{CO}_2$ . This approach has the advantage of being automatic and permitting continuous monitoring of radioactive  $\text{CO}_2$  (Morello, 1975). It should, however, be pointed out that accurate results can be obtained only when bacteria are grown in an acidic medium to prevent trapping the  $\text{CO}_2$  in the medium.

There are several commercially available instruments which afford continuous automatic monitoring. The best known is the BACTEC system (Johnston Laboratories, Cockeysville, Maryland) which represents an important advance in the field of automation for microbiology. It was originally designed to detect bacteria, automatically, in blood cultures and to test for sterility, but it may easily be used to monitor water quality.

With the BACTEC system, the sample is injected into a culture medium containing a  $^{14}\text{C}$ -labeled substrate. Thereafter, the culture vial is attached to a cylinder of gas (containing 10 percent  $\text{CO}_2$ ), connected to an ionization chamber, and incubated at the required temperature. At the start of the cycle, needles, which have not yet descended into the culture vial, are heated to sterility; and the pressure in the ionization chamber is lowered to about 1/2 atm. The needles then descend into the culture vial; gas from the cylinder is forced through a sterilizing filter into the vial and then swept out into the ionization chamber, where any radioactive  $\text{CO}_2$  is counted.

(ii) Isotope Incorporation Method. The fermentation methods just described are quite sensitive in that, a single coliform bacterium may metabolize many molecules of the radioactive carbohydrate; the amount of evolved radioactive  $\text{CO}_2$  is a function of cell number, incubation time, and temperature. Yet, these methods do have drawbacks. "Inactivated" coliforms, which are unable to multiply (due to chemical or physical water treatment), may still ferment the carbohydrate. To avoid inclusion of these in the results, alternative procedures have been proposed. Incorporation methods measure bacterial growth, usually to the exclusion of inactivated microorganisms. Khanna (1973) used a radio-metric assay, based on the synthesis of macromolecules, wherein he incubated bacterial cells with  $^{32}\text{P}$  and measured the amount of isotope incorporated into cellular nucleic acids. At the end of incubation, cells were collected on Whatman No. 40 filter paper, washed, dried, and their radioactivity determined. This procedure has been used for quantitating E. coli cells.

Radioactive phosphorus is not the only isotope which can be used for incorporation studies. Radioactive sulfur has been used in attempts to detect extraterrestrial life (Levin, 1968). This isotope may easily be used to quantify coliforms in water. Using radioactive phosphorous or sulfur has the advantage that these isotopes may be obtained at high specific activity (unlike radioactive amino acids, purines, or pyrimidines), facilitating labeling and quantitation of bacteria. However, they may present a health hazard because they emit relatively high-energy  $\beta$  particles; in addition, their short half-lives may lead to practical difficulties. Since sulfur isotopes would be incorporated into bacterial proteins and phosphorous isotopes, into

nucleic acids, they would permit the detection of bacterial growth, but could not be used, as such, for the identification of specific bacteria.

This procedure clearly requires modification before it can be applied directly to water quality control. Soil bacteria behave like coliforms in that both groups incorporate the radioactive elements. Therefore, inhibitors should be added to the growth medium to permit selective growth. Bile salts and related compounds probably would permit the growth of coliforms while inhibiting the multiplication of any bacteria not in the family Enterobacteriaceae.

Tritium-labeled amino acids, carbohydrates, or purines are usually not suitable for incorporation studies. These isotopes cannot be obtained at sufficiently high specific activities; therefore the assay is not very sensitive. On the other hand, iodinated amino acids may be used and would probably permit the detection of bacteria even in small numbers.

(iii) Application. Both the fermentation and incorporation methods provide means of testing for sterility and, as such, could be applied to water samples after chlorination or other treatment.

As mentioned earlier, radioactive lactose may be used to differentiate between coliforms and soil bacteria. Other radioactive carbohydrates may similarly be used and may help in classifying indicator types. Related biochemical properties of specific bacterial strains should also be considered. *E. coli*, for example, shows lysine decarboxylase activity, and releases radioactive  $\text{CO}_2$  when incubated with [ $^{14}\text{C}$ ]lysine (labeled at the carboxyl group). In this way, *E. coli* may be differentiated from other Enterobacteriaceae; when this test is run concurrently with [ $^{14}\text{C}$ ]lactose or [ $^{14}\text{C}$ ]glucose incubations, total coliform or total bacterial levels, respectively, may be ascertained.

Incorporation studies may be used to test the sensitivity of the organisms to various agents. Any decrease in isotope incorporation in the presence of the drug would be a sensitive indication of growth inhibition. By monitoring isotope incorporation, in parallel cultures incubated aerobically and anaerobically, one may identify aerobic and anaerobic bacteria.

(iv) Conclusions. The radioactive isotope method, applied either to bacterial fermentation or isotope incorporation, is a useful tool for the early detection, quantitation and identification of microorganisms in water. It can be automated and applied as an on-line system to signal any changes in water quality. The fermentation of radioactive substrates offers a means of differentiating E. coli from other coliforms, and coliforms from soil bacteria, but it does not necessarily distinguish between viable and inactivated organisms. Enzymatic reactions can be accelerated by certain modifications to increase radioactive CO<sub>2</sub> output, although initial rates of <sup>14</sup>C CO<sub>2</sub> production are not always linear due to metabolic lag periods or previous environmental exposure. Isotope incorporations permit easy, accurate coliform quantitation, but do not identify specific bacteria. The use of membrane filters permits detection of sparse bacterial numbers in large volumes of water. The procedures are sensitive and permit the detection of two to 20 coliforms within 6 h.

(v) Summary. There are two radioisotope methods applicable to drinking water microbiology: one based on fermentation, the other based on isotope incorporation. The fermentation method utilizes the ability of bacteria to metabolize specific <sup>14</sup>C-labelled compounds, whereby the <sup>14</sup>C CO<sub>2</sub> released can be trapped and quantified. A judicious selection of substrates, inhibitors, and reactions will enable detection of specific groups such as coliforms.

b. Impedance Methods. The impedance technique offers potential as an automated, rapid, and non-specific indicator of viable microorganisms, analogous in several ways to the use of ATP [See Section C.3.b]. Both detect only viable microorganisms, and the response of both is a function of the number of viable organisms present. No work, however, has been published on the use of impedance for microbiological monitoring of drinking water, although this technique has been applied to microbiological problems in a number of other areas.

The impedance technique has been applied to several problems of practical importance in clinical microbiology, food microbiology, wastewater management, and environmental monitoring. Using this method, clinical microbiologists can screen rapidly for: microorganisms' tolerance of, or susceptibility to, antibiotics (Ur and Brown, 1974, 1975a;

Cady, 1978); clinically significant populations ( $< 10^5$  per ml) in urine samples as a means of diagnosing bacteriuria (Cady, 1978); evidence of infection in blood samples (Hadley and Senyk, 1975); and pathogen characterizations and identifications, such as for Neisseria gonorrhoeae, by simultaneous impedance responses to multiple substrates and media (Hadley and Senyk, 1975; Cady, 1978). The impedance technique can be used to measure the rate of microbial sulfate reduction in pure cultures of anaerobic sulfate reducing bacteria and in estuarine sediment samples (Oremland and Silverman, 1979).

(i) Principles Underlying the Use of Impedance. When microorganisms in an aqueous medium metabolize, they generate a complex series of reactions whereby higher molecular weight substrates are converted by extracellular enzymes to lower molecular weight compounds. These, in turn, are metabolized at or within cell surface structures, or they are metabolized internally. Also, other lower molecular weight organic and inorganic compounds are transported into the cell, often accompanied by an influx or efflux of inorganic ions. Eventually, metabolic products of lower molecular weight, including gases, accumulate in the aqueous environment outside the cell. As a result of microbial growth, electrically charged molecules and ions in the water will change in species and increase in concentration over time.

If an electric current is passed through the solution between two electrodes, a decrease in resistance (with direct current) or impedance (with alternating current) will occur as ions and electrically charged molecules increase in concentration and relative mobility. Reactions also will occur at or near the surface of the electrodes when charged molecules or ions are attracted to or adsorbed on the electrode surface, causing the electrode to act as a capacitor. Thus, the entire system can best be visualized as a circuit containing both a resistor and a capacitor in series. These concepts are discussed more extensively by Cady (1978). Other discussions on principles and applications in microbiology may be found in Cady (1975), Cady and coworkers (1978), Ur and Brown (1974; 1975a,b), Hadley and Senyk (1975), Munoz and Silverman (1979), Silverman and Munoz (1979), and Oremland and Silverman (1979).

A certain minimum number of growing microorganisms must be present before a detectable impedance signal will be

delivered. When numbers lower than the minimum are present, there will be a lag period of no detectable change in impedance signal, until populations reach the minimum detectable size -- among the bacteria, this number is generally  $10^6$  to  $10^7$  per ml. The lag period, or detection time, is inversely proportional to the number of viable microorganisms present at zero time, and can be as short as one hour for an inoculum of  $10^5$  to  $10^6$  cells, or as long as 18 h for one cell (Cady, *et al.*, 1978; Ur and Brown, 1974, 1975a; and Silverman and Munoz, 1979).

(ii) Instrumentation. Two commercial instruments are available at present for measuring impedance changes generated by microbial metabolism. The Bactometer is available from Bactomatic, Inc., Palo Alto, California, U.S., and the Bactobridge (formerly called the Strattometer) can be obtained from T.E.M. Sales, Ltd., Crawley, Sussex, U.K., or from Koniak and Partners, Ltd., Geneva, Switzerland.

The Bactobridge, described by Ur and Brown (1974), employs a matched pair of borosilicate glass capillary cells 30 mm in length and 2 mm internal diameter, plated at both ends with a gold coating. One cell, used as the reference, is filled with a sterile nutrient medium, while the sample cell contains nutrient medium inoculated with the sample. Both cells are inserted into the Bactobridge where, in order to avoid extraneous effects on impedance, a constant temperature is maintained to within  $0.1^\circ\text{C}$ . A 10 KHz sinusoidal alternating current, maintained below 0.5 volts, is passed through both cells in a bridge circuit. The bridge circuit is balanced initially using a 10 turn 1 Kohm potentiometer. Thereafter, any impedance imbalance in the bridge circuit, due to microbial metabolism, in the sample tube is amplified, rectified, and recorded continuously on a chart recorder. The only signal obtained, therefore, is that which relates to the activity of the microorganisms. The use of the Bactobridge in microbiology was described by Ur and Brown (1974; 1975a,b).

The Bactometer, described by Cady (1975; 1978) and Cady, *et al.* (1978), detects growth by measuring the increase with time in the electrical impedance ratio,  $R_z$ , between an inoculated sample vial and an uninoculated sterile reference vial (both vials contain nutrient medium), according to the relation:

$$R_z = Z_{\text{ref}} / [Z_{\text{ref}} + Z_{\text{sample}}],$$

where  $Z_{\text{ref}}$  and  $Z_{\text{sample}}$  are the impedance of the reference and sample vials, respectively. In theory, the impedance

ratio at zero time should be 0.5000 with identical solutions in the sample and reference vials. As cells grow and metabolize and the impedance of the inoculated sample declines accordingly, the  $R_z$  will approach 1.0000. In practice, initial impedance ratios ranged from 0.4500 to 0.5500 (Silverman and Munoz, 1979). More detailed descriptions of the Bactometer and the theory and practice of impedance ratio measurements of microbial growth and metabolism have been published elsewhere (Cady, 1975; Cady, 1978; and Hadley and Senyk, 1975).

The Bactometer model 32 accepts up to 32 sample/reference pairs in four modules of eight pairs each. The instrument generates an alternating current of either 400 or 2,000 Hz, passes it through the electrodes of a sample/reference pair every 3 sec, reads the impedance ratio, then indexes automatically to the next pair. A complete cycle of 32 sample/reference pairs is read every 96 sec. The impedance ratio output for each pair is recorded on individual channels of a 32-channel strip chart recorder and displayed simultaneously on the face of the instrument. The Bactometer also converts the impedance ratio data into a form readily stored in a computer for subsequent processing. A variety of disposable sample/reference tubes is available, with total volumes ranging from 2 ml per tube up to 100 ml or more, complete with stainless steel electrodes.

(iii) Evaluation of Impedance in Microbiology. All species of bacteria, yeasts, and fungi tested, that produce visual evidence of growth in broth cultures, generated a detectable impedance signal. Included are many species important in public health, such as Escherichia coli, Streptococcus faecalis, Klebsiella pneumoniae, Pseudomonas aeruginosa, Salmonella enteritidis, Staphylococcus aureus, and Shigella species. Lists of microbial species that have been detected by the impedance technique were published by Cady (1978) and Cady and coworkers (1978).

A selective medium was introduced into multiple sample units of the Bactometer 32 to provide a rapid, single-step most probable number method for enumerating fecal coliforms in sewage treatment plant final effluents (Munoz and Silverman, 1979). A linear relation was found between the  $\log_{10}$  of the number of fecal coliforms in the inocula of sewage treatment plant effluents and the detection time by the impedance technique. This permitted the preparation of standard curves of  $\log_{10}$  thermo-tolerant coliforms, plotted

against detection time, for determining the number of fecal coliforms in wastewater directly from the detection times. Thermo-tolerant coliform counts obtained with this method were in excellent agreement with counts obtained by the standard MPN procedure (Silverman and Munoz, 1979).

Detection times determined for varying numbers of microorganisms in frozen vegetables correlated with numbers determined by the standard plate count method. This enabled detection times by the impedance technique to be employed in screening frozen vegetables for unacceptable levels of bacterial contamination (Cady, 1978).

(iv) Application of the Impedance Technique to Drinking Water Analysis. One problem common to all methods for detecting and enumerating microorganisms in drinking water is that of low numbers per unit volume. With respect to the impedance technique, strategies can be employed to overcome the problem. By accepting multiple samples, the Bactometer 32 should be able to perform a single-step MPN enumeration, as was demonstrated for thermo-tolerant coliforms in wastewater (Munoz and Silverman, 1979). Sample bottles and vials of up to 100 ml or more capacities are available, so that it should be possible to use larger sample volumes (i.e., greater than the 1 ml maximum in agar plating techniques) for relating detection times to numbers of microorganisms in a sample. Alternatively, methods for concentrating organisms could be employed; for example, collecting them on membrane filters, incubating the filters in an appropriate medium, and relating numbers to detection time.

Specificity can be incorporated as part of the impedance technique by the judicious use of selective media, temperatures, antibiotics, etc., when particular genera or species are sought. The impedance technique should prove useful particularly in cases where sample turbidity precludes the use of membrane filter techniques or standard plate counts. Turbidity will not affect microbial generation of an impedance signal, nor interfere with its detection. Finally, the instrumentation, commercially available, provides automated and simultaneous analyses of multiple samples, affording more frequent microbiological monitoring. In addition, its capacity for computer data storage and processing provides users with the opportunity for obtaining retrospective analyses of long-term trends in microbial types and numbers within a water supply.



(v) Summary. Metabolic processes and products of bacterial growth measurably decrease the resistance of an electrical current passing through the growth medium. In this way, the impedance method can be used to detect all viable organisms present in a sample. Selection of appropriate media and growth conditions will enable detection of a specific group of organisms or even one species. The method is extremely sensitive and can yield results in as little as one hour for highly polluted water, or in up to 18 h or longer for a single cell. Although the impedance method has been employed with several bacterial species of public health and sanitary significance, it has not yet been extensively tested for use with drinking water.

c. Automated Sampling, Plating and Incubation. Even though much is now known about water pollution, the problem continues to grow with industrialization and urbanization of society. The bacteriological control of drinking water quality is indispensable in this context; but methods presently used for the purpose have shortcomings, in that sampling is periodic, transporting of samples imposes additional quality control problems, and results represent a static image of a dynamic system. Variations in the bacteriological quality of a water supply may result from human activity, but also from that of wildlife [See Section B.2], and from climatic [See Section B.3] and geologic [See Section A] changes. An ideal method would take into account changing conditions and make possible the determination of a most probable contamination risk.

A logical solution may lie in the application of continuous sampling at selected sites at a water source, at the treatment plant, and along the distribution network [See also Sections 4.a to e]. Although continuous sampling is attainable with conventional manual methods, particularly the membrane filtration technique [See Sections C.1.b to c, C.4.f, C.4.h, D.2, and D.4] greater potential could be realized with the development of automated sampling and analytic equipment. Since these may be installed at a sampling site, the use of such devices would obviate the need for transport.

Several conventional techniques could also serve as a basis for automated procedures, although some obviously would lend themselves more readily than others to automation. Thus, the multiple tube fermentation technique [See Sections C.1.b to c, D.3, and D.5] would require extensive adaptation for use with automated equipment, which would not be practical. The membrane filtration technique, on the other hand, holds

more promise. This technique has been simplified for use as a manual procedure, but not as applied to automation.

A laboratory prototype model for automated sampling and bacteriological analysis has been developed and was exhibited at the Symposium on Rapid Methods and Automation in Microbiology, held in Stockholm in 1973. The apparatus is divided into three components: a vessel through which water is pumped, continuously, from the source to be tested; a compartment for storing 24 culture plates of a suitable solid medium; and an incubation chamber. The prototype works on a direct current of 6 V. It is equipped with a transformer and can run on the main supply. It also is connected to a battery for auxiliary power, should the main current fail.

Water, entering continuously into the first container, is aspirated at preset intervals of 15, 30, or 60 min for inoculation onto the culture plates. As each culture plate is transferred from the storage compartment to the incubation chamber, the lid is removed, and a measured dose (may be adjusted to any volume between 0.2 and 2.0 ml to permit testing of up to 48 ml of water in each series) of sample water is swept evenly over the medium. A rinse cycle with fresh water follows each inoculation to avoid any bacterial transfer to consecutive samples. The inoculated plate passes to the incubation chamber, which may be set at 22, 30, or 37°C.

This model was initially devised for use in the event of a catastrophe or war. However, the advantages to be gained from such a system during normal times are many. Soon-to-be-published results from pilot studies using this prototype have demonstrated the efficacy of automated bacteriological monitoring of water from different sources. An industrial adaptation of the prototype, incorporating the latest developments in electronics and automation, might enable a wide variety of individual water analyses.

Work is now in progress to increase the versatility of the model. For example, ways are being sought to incorporate the detection of anaerobic sporeformers, such as Clostridium perfringens, and to permit dilution of samples of highly contaminated water or concentration of samples for analysis of finished water.

d. Automated Plate Counting. One of the most slow, tedious, and routine laboratory procedures practiced today is the counting of certain groups of organisms or total numbers of colony-forming units for water quality assessments or ecological investigations. Raw, as well as finished, water contains indigenous and exogenous microorganisms in constantly changing numbers [See Section A] and studies of the bacteriological quality or population dynamics of a water source usually entail extensive quantification. Depending on the purpose of the investigation and the microbial composition and density of the sample, counts generally are taken on spread plates, pour plates, or membrane filters [See Sections C.1 and D].

Automated colony counting instruments, recently developed and made available, promise to reduce the monotony that comes with manual counting and help greatly in microbiological testing by the spread plate, pour plate, and membrane techniques if the operational characteristics are fully understood.

(i) Principle of Automated Counting. The instrument usually consists of a viewing monitor and an electronic counter. A high resolution television (tv) camera functions as a rapid scanning light detector that recognizes signals from a bright field/dark field light source moving horizontally in parallel lines over the culture plate. The camera is connected to an electronic circuit with a counter and a digital readout. Usually, a tv monitor is also connected to present an enlarged picture of the culture plate. This magnified view makes it easier for the operator to fix the electronic window precisely on the area to be counted.

The position and size of the window, as well as its shape (circular, square, or rectangular) are all adjustable. Adjustments for colony size and optical density (referred to as sensitivity) also are manually set so that any object exceeding that threshold setting will be counted. Appearing on the monitor screen will be an illuminated marker dot superimposed over the object to be counted, enabling the operator to check for a correct threshold setting that will tune out smaller particles and debris and count all colonies. The automated counter usually can be connected to a computer for easy data handling and storage.

(ii) Sensitivity and Accuracy. What will constitute the smallest detectable size depends on the magnification of

the camera lens, the number of lines in the scanning pattern, the spot diameter, and the level of contrast between the colony and the plate. The contrast level, in turn, is determined, in large measure, by the type of illumination employed.

Since what is recognized by the counter is the difference in light intensity between the background and the colony, the opacity of the agar and, therefore, the type of illumination applied is of major importance.

There usually are three types of illumination from which to choose. Reflected light is used with membrane filters or spread plates that contain opaque or colored agar media such as blood or chocolate agar. Membrane filters also can be counted using reflected light, but only ungridded filters are acceptable since grid marks may interfere with detection and produce inaccurate counts. Gridded filters serve only as a guide in manual counting and should, if possible, be avoided when using the automated counting device.

Transmitted light is preferable when the medium used is relatively transparent (as with pour plates) and the contrast normal. Colonies near the bottom of the dish that are low in contrast may not be counted, but applying an underlay of sterile agar usually will overcome this effect. Use of transmitted light also permits counting of plaques [See Section C.2.a], lipolytic zones, and the like, when cleared spots contrast with the agar by > 20 percent. Detection is possible at lower contrast with an auxiliary dark field illuminator.

With an ordinary 50 mm lens, objects measuring about 0.2 mm can be counted if the contrast level approaches 100 percent. If the contrast is low, the colony must be at least 0.4 mm in diameter. This was demonstrated in an earlier evaluation (Goss, *et al.*, 1974) in which colonies could be counted manually after 18 h, having attained a mean diameter of 0.17 mm; but they were detectable by automated counting only after 48 h, when they had reached a mean diameter of 0.31 mm. With a 75 mm lens, colonies 0.1 to 0.2 mm in diameter (approximately the limit of resolution for the human eye) are readily detectable.

(iii) Correcting for Variables. Automated counts would tend to be somewhat lower than manual counts without

application of a correction factor. This calibration adjustment takes into account distortions or error from colonies that overlap or that are masked at the periphery of the plate.

Overlapping or clustered colonies separated by  $< 0.3$  mm will be counted as multiple or single units depending on their orientation to the scan lines. It is possible, however, to calculate the probable frequency of colonies spaced  $< 0.3$  mm apart if the original sample was homogenous and distributed uniformly over the medium. This is because the frequency with which colonies cluster increases in proportion to the bacterial density of the sample (Goss, et al., 1974; La Grange, et al., 1977; Miller, et al., 1975). Once determined by experimental manipulation and set on the machine, this correction factor will adjust the count automatically, but it should be applied only within a range of 50 to 500 counts since densities above or below are subject to variation from other factors.

(iv) The Spiral Counter. A special type of automated counter has been developed for use with the spiral plate method. Here, a small volume (35  $\mu$ l) of sample is deposited on the surface of a rotating agar plate in decreasing amounts from the center to the edge, forming an Archimedes spiral. The method enables the counting of a single plate for samples having a 10,000-fold range of bacterial concentrations (Gilchrist, et al., 1973). Counting is accomplished with a laser electronic counter, designed to record a preset number of colonies that have developed from the edge to the center of transparent plates. If the plate contains more than the preset number, the counter stops and displays the area in which the count is made. The count per milliliter is then determined from a calibration curve (Donnelly, et al., 1976). This method is of potential value for counting colony-forming units from different quality waters where the total count exceeds 1,000 per ml.

(v) Agreement with Manual Counting. Good correlations have been obtained in published comparisons using pure cultures (Brusick, 1978; Fruin and Clark, 1977; Goss, et al., 1974), mixed flora of human origin (Goss, et al., 1974), cultures from dairy products (Fruin and Clark, 1977; LaGrange, et al., 1977), and cells forming plaques from antibody production (Katz, et al., 1977). There apparently have not been any published accounts comparing organisms

from raw water or slower growing organisms. Nevertheless, the 14th edition of Standard Methods (American Public Health Association, 1975, p. 911) states with regard to automatic counters: "Their use is acceptable if evaluation in parallel with manual counting gives comparable results."

(vi) Advantages and Disadvantages of Automated Counting. The major advantage of automated counting is the savings afforded in time and labor. Counting time, including manual adjustments and allowance for any operator error, is less than one-third that of manual counting. Automated counting also minimizes manual count variations due to carelessness, fatigue, or other factors leading to human error or to differences in technique. Several unpublished studies have been made on this subject, including one by the American Public Health Association, in which it was found that for 95 percent of the manual counts, differences between technicians counting the same plates varied by  $\pm 24$  percent.

Scratches, irregularities in the agar, air bubbles, dust particles, and particles from the sample may be counted with both transmitted and reflected light, giving mistakenly high numbers. When illumination is by transmitted light, stacking ridges and marks such as finger prints on the petri dish can interfere with the count. Dust particles on the camera lens also may interfere. These problems are most evident with plates containing few colonies (Fruin and Clark, 1977), very small colonies, or with plates requiring adjustment to a high sensitivity. Adjusting the colony size or re-adjusting the sensitivity control to tune out smaller particles and irregularities usually will overcome these interferences. This is not always possible, however, with small colonies. Instead, a zero count can be taken for the freshly poured, spread, or filtered plates before incubation, and then subtracted from the final count. Here, it is necessary to put the plates in the same fixed position so that any scratches or elongated particles hold the same orientation, as before, to the scanning lines.

The automated counter does not distinguish between colonies of different color. Therefore, only if the background flora are quite minimal, as with the thermo-tolerant test [See Section C.1.c], should automated counting be used. Otherwise, with tests such as that for total coliforms [See Section C.1.b], where background growth is more developed, automated counting is of limited value.

Plates with mold colonies, filamentous bacteria, or surface spreaders are not well suited for use with automated equipment and should be counted manually. Anaerobic cultures incubated on spread plates may be a problem, since many of these colonies normally have a very low contrast, along with a tendency to spread at times.

(vii) Applications of Automated Counting. Automated counting is useful for all types of studies with pure cultures, and for many others using mixed cultures where the total number of colonies is to be counted. Differentiation of colonies by aspects other than size, however, is less applicable.

Automated counters can be used with spread plates and pour plates and with ungridded membrane filters (when tests are highly selective). Since cleared zones also can be counted when the dark field illuminator is used, automated instruments probably can be employed for enumerating coliphages and cyanophages from different quality waters [See Section C.2.a]; or they might serve in studies of biochemical differentiation, for example, with quantification of cleared zones of lipolytic organisms. An auxiliary camera mounted on a photomicroscope enables objects to be counted automatically. The automated counter also can be connected to a computer programmed for statistical compilations to speed handling of the numerous data entries.

(viii) Summary. Although the applications of automated counters are many, it is still the operator and not the machine who make the judgments. The automated counter is no more than a useful tool in the laboratory that can help to release the technician from boring, repetitive, and time-consuming work. The high resolution television cameras with high quality lenses are used to count colonies as small as 0.1 mm in diameter, and can be used with transmitted or reflected light. The major advantages over manual methods are the greater speed and lower cost of automated counting. The major disadvantage is the inability of the device to differentiate between colonies and other objects in the same size range or to distinguish colors. Advances in data processing methods speed up the handling of the voluminous data generated.

e. Automatic Enzymatic Methods. Current techniques for the bacteriological monitoring of finished water have

been of value in combating waterborne epidemics, but are not without shortcomings. Some of these shortcomings may be overcome by a recently developed, automated method which is based upon the Technicon auto-analyzer. Current water sampling and analytical practices entail a series of disjointed, lengthy steps including sample transport and preparation, as well as multi-phased laboratory procedures. This not only invites mistakes, but permits only intermittent sampling and analysis. Moreover, the coliform test, on which monitoring of finished water is based, has proved liable to misinterpretation.

The major advantages of the new apparatus are its automated and continuous performance, its ability to be installed at the water treatment site, and its increased sensitivity to the detection of E. coli (an indicator of well established significance). This selectivity for E. coli is accomplished by the introduction of a glutamate solution under strictly controlled conditions of pH and temperature. E. coli was shown to carry on continuous biosynthesis of glutamic acid decarboxylase (GAD), and surveys of various bacterial species encountered in water indicate that GAD production is limited to E. coli, Shigella, Proteus rettgeri, P. hauseri, and Clostridium species (Leclerc, 1967; Leclerc and Catsaras, 1967). Shigella is only rarely recovered from water and poses no problems of interference. From the authors' experience, P. rettgeri and P. hauseri are always associated with E. coli and occur in polluted water. Clostridium species are unable to survive aerobic conditions imposed in this analytical method. Therefore, the test is highly specific for E. coli and exclusively so for fecal contamination.

(i) Sampling and Culturing Mechanism. The entire apparatus is shown schematically in Figure C.4.e-1. It operates on the basis of continuous and sequential flow by means of a peristaltic pump. A 3-way valve (constructed in a T-shape to eliminate problems of contamination arising from dead volume) enables attached silicone feeder tubes to separately draw up water sample and culture medium [See Figure C.4.e-2], after which these are mixed.

To compensate for the low volume of flow dictated by this model, a hollow fiber ultrafiltration unit was designed to reduce an initial 100 ml volume to 5 ml (Trinel and Leclerc, 1976). The Technicon auto-analyzer can, in this way, accommodate 120 water samples of 100 ml each (or 12 l) daily, accomplishing analysis of 100 ml every 12 min.



FIGURE C.4.e-1

AUTOMATIC APPARATUS FOR CONTINUOUS TESTING FOR E. COLI IN WATER: SCHEMATIC DIAGRAM

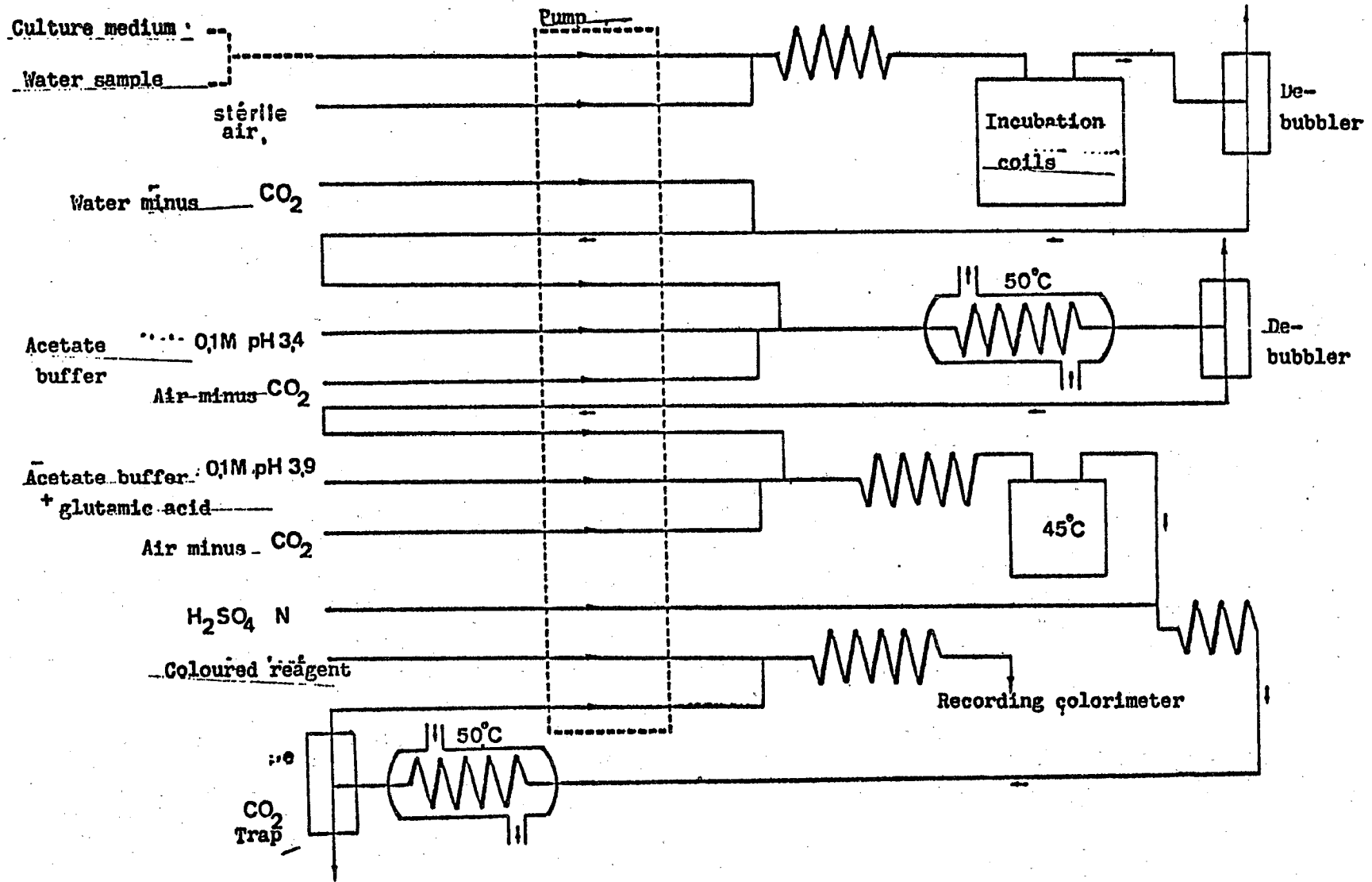
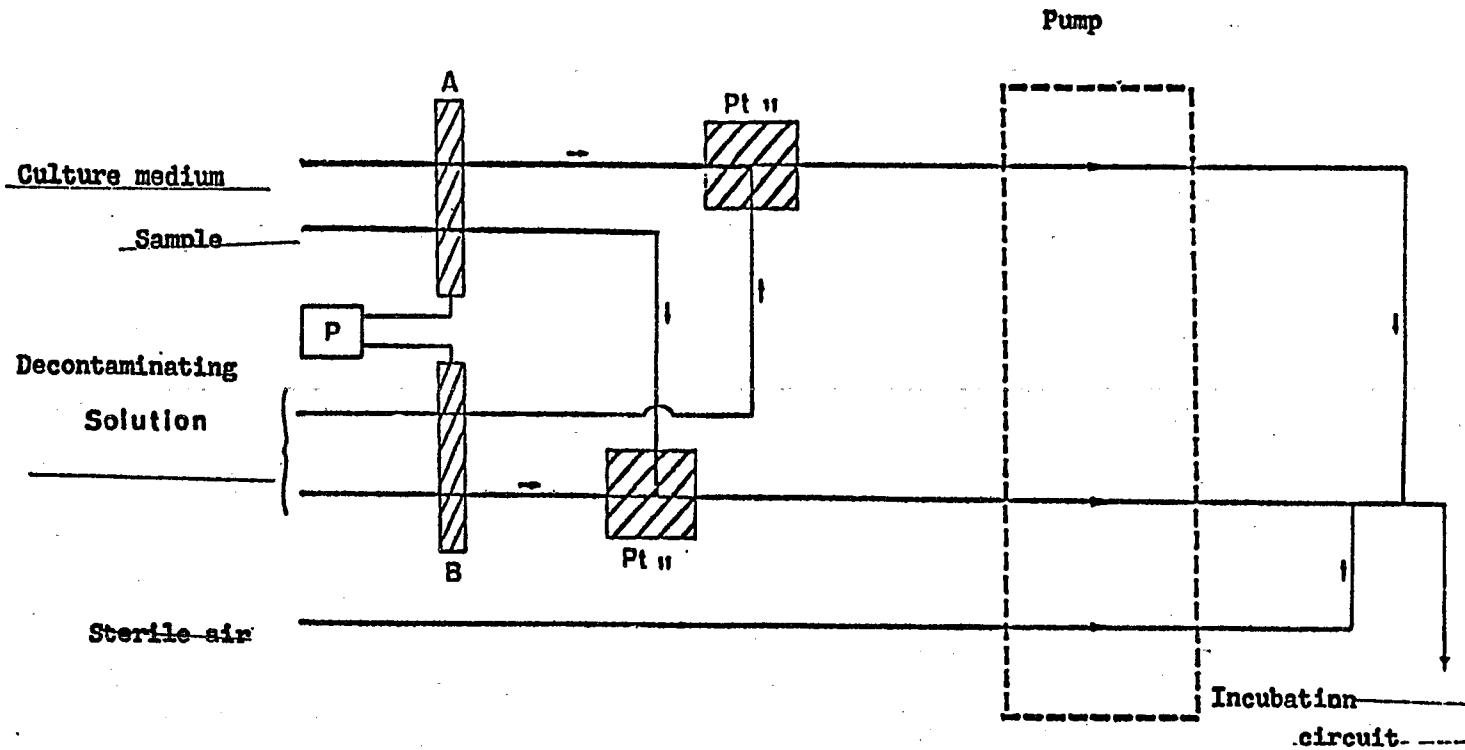

FIGURE C.4.e-2

SEQUENTIAL DIAGRAM OF INTRODUCTION OF SAMPLES, CULTURE MEDIUM AND DECONTAMINATING SOLUTION  
A & B: PNEUMATIC LIFTERS ALTERNATELY CLOSING OFF THE TUBES SUPPLYING CULTURE MEDIUM,  
WATER SAMPLE AND DECONTAMINATING SOLUTION



P: Programmer

P<sub>11</sub>: T-valves

The growth medium is a buffered lactose broth (BLB) which selectively cultures for any E. coli present in the sample [See Table C.4.e-1]. The consistent and selective growth of fecal coliforms (especially E. coli) on BLB medium is achieved by, and contingent upon, strict adherence to a pH of 6.8 (using phosphate buffer) and a temperature of 41°C. Soil and water coliforms (e.g., Citrobacter and Enterobacter) do not grow well in this medium, and the growth of aquatic bacteria (e.g., Pseudomonas, Aeromonas, and Acinetobacter) is greatly inhibited. Research by Trinel and Leclerc (1976) indicated that this medium was more sensitive and efficient in promoting the growth of E. coli than conventional techniques.

Phthalate HCl-buffer, a disinfectant which is introduced between sample volumes, both sterilizes passages and separates one water sample from another, thereby preventing any cross contamination of consecutive samples. Yet, once diffused into the medium, phthalate buffer takes on the pH of the medium and imparts no harmful effects to incubating cultures. The continuous circulation of microorganisms throughout the system makes the issue of disinfection a critical one. Phthalate HCl-buffer (0.047 M at pH 2.4) appears, from results of experiments conducted in our laboratory, to offer an effective means of decontamination.

The mixture of sample and medium next enters a coil of glass tubing maintained at 41°C in a water bath. Incubation proceeds for approximately 12 h, during which time sterile air is bubbled through to provide oxygen for bacterial growth.

(ii) Glutamic Acid Decarboxylase (GAD) Detection. As the culture medium leaves the incubation coils, all gaseous fermentation products are bubbled off and the remaining liquid is diluted with sterile water from which all carbon dioxide has been removed. Sulfuric acid, added after 25 min, liberates evolved carbon dioxide which is recovered and measured by a colorimetric response with phenolphthalein reagent. Results are recorded as colony forming units (cfu) per 100 ml, permitting a detection accuracy of one or less than one E. coli per 100 ml.

(iii) Summary. An apparatus has been devised which is particularly suited to the on-site (i.e., treatment plant, reservoir, or water main) sampling and analysis of water

TABLE C.4.e-1

## BLB FORMULATION

---

---

Meat extract (Liebig)	3.0 g
"Bacto-tryptone" (Difco)	10.0 g
Lactose	4.0 g
Yeast extract (Difco)	3.0 g
Sodium chloride	5.0 g
Monopotassium phosphate	6.0 g
Disodium phosphate · 12 H <sub>2</sub> O	19.7 g
Distilled water	q.s. 1000 ml

---

supplies. It operates continuously and automatically, thereby eliminating manual procedures and providing for uninterrupted monitoring. Daily water volumes of 10 to 20 l may be analyzed within 12 to 13 h using ultrafiltration. The technique employed is highly sensitive to and specific for E. coli, as measured by the presence of carbon dioxide evolved from the biosynthesis of GAD.

f. Rapid Thermo-Tolerant Coliform MF Method. Temporary disruptions to the water supply (e.g., water treatment plant failure, line breaks in a distribution network, or other natural or man-made disasters) create an urgent need for methods that permit rapid assessment of the sanitary quality of the water. The 7-h membrane filter fecal (thermo-tolerant) coliform test (M-7h FC) provides results equivalent to those obtained using the conventional 24-h thermo-tolerant coliform procedure employed in the U.S. [See Section C.1.c] and can thus serve as a rapid, preliminary read-out while awaiting the 24-h test results. Accordingly, the M-7h FC test offers a means of detecting gross contamination of potable water in emergency situations, permitting more rapid responses and decisions by public health or other officials.

(i) \ Principles Applied to this Method. The M-7h FC test uses a lightly buffered lactose-mannitol based medium that contains an acid-sensitive indicator system (Reasoner, et al., 1976). To lessen the adverse effect of higher temperatures upon recovery of thermo-tolerant coliform organisms which may have been stressed by disinfectants, the incubation temperature has been reduced to 41.5°C (Van Donsel, et al., 1969). During 7 h of submerged incubation, thermo-tolerant coliforms ferment lactose to acid, causing the color of the indicator to change from purple to yellow. The thermo-tolerant coliform colonies typically appear yellow against a purple background; all yellow colonies are counted as thermo-tolerant coliforms.

(ii) Medium Preparation and Procedure. The medium may be obtained from Difco or prepared in the laboratory [See Table C.4.f-1]. It can be prepared in bulk quantity by mixing the dry ingredients and storing in a clean jar in a dry, warm place, or in a dessicating chamber to prevent absorption of moisture from the air. The medium is prepared for use by adding the appropriate quantity of the mixed dry

TABLE C.4.f-1

M 7-h FC  
MEDIUM FORMULATION<sup>a</sup>

---

---

Proteose peptone No. 3	5.0 g
Yeast extract	3.0 g
Lactose	10.0 g
D-Mannitol	5.0 g
Sodium chloride	7.5 g
Sodium lauryl sulfate	0.2 g
Sodium desoxycholate	0.1 g
Brom cresol purple, free acid	0.35 g
Phenol red, water soluble	0.3 g
Agar	15.0 g
Distilled water	1,000 ml
Final pH	7.3

---

<sup>a</sup>All ingredients are manufactured by Difco Labs., Inc., except sodium chloride, brom cresol purple, and phenol red which are manufactured by Fisher Scientific Co.

medium to the required volume of laboratory quality distilled water. The medium is then heated to boiling to dissolve the agar. The final pH of the prepared medium should be adjusted to  $7.3 \pm 0.1$  using sterile 0.1 N NaOH or 0.1 N HCl. Plates are prepared by dispensing 5 to 6 ml of the melted M-7h FC agar into small (50 x 12 mm or 60 x 15 mm) petri dishes and allowing the agar to solidify. The prepared plates can be stored in the dark at 2 - 8°C for up to two weeks.

Water samples are tested by passing an appropriate volume (up to 100 ml) through a membrane filter [See Section C.1.c]. Membrane filters are then placed on the agar plates (taking precautions to avoid trapping any air bubbles), put inside watertight plastic bags, inverted, and submerged in a 41.5°C water bath for 7 h. Plates with 20 - 60 yellow colonies are counted using a binocular wide-field dissecting microscope. Colonies are recorded as numbers per 100 milliliters.

(iii) Accuracy and Verification of Results. Results from a study of thermo-tolerant coliform differentiation (Geldreich, 1975) showed that 94.3 percent of the yellow colonies from the 7-h medium verified as thermo-tolerant coliforms; when the same samples were analyzed by the 24-h thermo-tolerant coliform method, 93.7 percent of the blue colonies verified as thermo-tolerant coliform. These data indicate that both media measured essentially the same population of bacteria. Both the 24-h and the 7-h tests underestimate the actual thermo-tolerant coliform density.

(iv) Summary. A 7-h membrane filtration method for thermo-tolerant coliforms (M-7h FC) has been developed that is suitable for determining gross contamination of potable water in emergency situations. It gives results equivalent to the conventional 24-h thermo-tolerant coliform test routinely used in North America. After 7 h of incubation, thermo-tolerant coliforms appear yellow against a purple background. About 94 percent of the yellow colonies can be verified as thermo-tolerant coliforms.

g. Presence Absence Test. Routine analyses of drinking water samples from municipal distribution systems traditionally have been designed to quickly signal the presence and numbers of total coliforms. Initially, most laboratories used the most probable number (MPN) procedure for

this function [See Section D.3.]. However, MPN analyses are rather time-consuming, and the incubation period can extend up to four days before numerical results are available.

The membrane filter (MF) technique [See Section D.2] was introduced in the late fifties as an alternative to the MPN procedure. This technique yields results approximately equivalent to the MPN procedure, but it does so within a 24-h period and requires less preparation. In addition, numerical results from the MF method have been more consistent among samples from the same location.

Sudden, unexplainable instances of pollution occurring in a distribution system and leading to disease outbreaks are relatively rare. Aside from main breaks or equipment failure in the treatment plant, water quality deterioration in a distribution system is more likely attributable to a gradual process of microbial degradation, engendering bacterial slimes, corrosion, or encrustation [See Sections F.2 to 3 and G.2 to 4]. Distribution systems may, in fact, exert their own influences upon finished water, producing conditions whereby slower growing debilitated bacteria or pollution indicators of non-fecal origin may become established. This microbial activity will produce sediments and tubercles that reduce flow rates [See Section G.3], and will create a need for increased chlorination to prevent regrowth and to afford adequate disinfection.

The presence-absence (P-A) test is a simple, inexpensive procedure for the rapid, qualitative detection of fecal indicators (e.g., *Escherichia coli*), as well as indicators of marginal water quality (i.e., slower growing, debilitated bacteria and water bacteria which cause sliming and fouling of distribution systems). The test, as such, would be advantageous to laboratories with limited time and resources. This method, in use for over ten years by the Ontario Ministry of the Environment Laboratories (Canada), supplies results satisfying the criteria enumerated above when used on drinking water samples submitted daily or weekly. Since 90 percent of the samples are ordinarily free of pollution indicators, there is no need to provide quantitative results for each sample.

(i) Procedure for Conducting the P-A Test. Fifty or 100 ml of drinking water samples are added to double or triple strength MacConkey (MacC) broth (respectively) contained in P-A bottles with inverted durham tubes. Samples



and medium are mixed so as not to permit any stratification of the concentrated medium which would inhibit growth. The P-A bottles are incubated at 35°C for four days and checked every 24 h for acid production (with or without gas), as evidenced by the color yellow. If, after three or four days of incubation, only a slight acid reaction is apparent, cultures should be checked for the presence of Staphylococcus (see below).

Pollution indicator types are determined by inoculating presumptive-positive cultures into confirmatory media, diagrammed in Figure C.4.g-1 and described previously (Clark, 1969; Clark and Vlassoff, 1973). Most laboratories will find that the initial confirmatory tests provide sufficient information for assessing the sanitary quality of the water. However, further taxonomic tests may be applied to isolated cultures if more definitive information is required.

Tests for confirming fecal and total coliforms are easily performed. Only fecal coliforms produce gas in the EC broth at 44.5°C; but both fecal and total coliforms produce gas in the EC broth at 35°C; and both produce lactose fermenting colonies on MacC agar. If lactose fermenting colonies are evident on MacC agar, but gas is not seen in either of the EC broth tubes, the organisms are anaerogenic coliforms (debilitated coliforms which have lost the ability to produce gas from lactose fermentation), or aeromonads. Aeromonas can be readily distinguished from anaerogenic coliforms by streaking on a non-carbohydrate medium such as Nutrient-Gelatin agar, and performing an oxidase test on 24 h colonies. If a good growth of only non-lactose fermenters appears on MacC agar, these colonies should be identified further with taxonomic tests.

Gram-positive organisms, including Staphylococcus, Micrococcus, and Bacillus sp. are frequently present when gram-negative organisms are absent from any of the other confirmatory media. When grown on Mannitol-Salt agar, Staphylococcus produces convex, yellow colonies surrounded by a yellow zone. Micrococcus types usually produce white or colorless colonies with no evidence of mannitol utilization. Some Bacillus species which produce mucoid, yellow colonies may be distinguished with a Gram stain.

Although Pseudomonas aeruginosa grows vigorously in P-A bottles and may dominate in mixed cultures, its presence may go unnoticed because of its inability to ferment lactose. It

will, however, be noticed if, for coliform confirmation, the organism is streaked onto MacC agar plates. P. aeruginosa can be detected and differentiated using Drake's broth (Drake, 1966), incubated at 41.5°C. Each day for four days, tubes are checked for any fluorescent growth. Cultures from positive tubes are inoculated onto Skim Milk agar, or onto Milk agar which is prepared in the laboratory according to the Brown and Foster modification (American Public Health Assoc., 1975), and incubated at 35°C for 24 h. P. aeruginosa hydrolyzes casein, producing typical green colonies.

Fecal streptococci, when present alone in P-A bottles, produce acid with no gas, but the same is also true for anaerogenic coliforms or aeromonads. To confirm the presence of fecal streptococci, cultures are inoculated into Ethyl Violet Azide (EVA) broth and onto Enterococcus (Enterococcus) agar.

Clostridium perfringens reacts in either of two ways in P-A bottles: it may produce abundant gas and acid in the MacC broth, thus resembling a coliform reaction; or, it may produce abundant gas, but confer a bleached, pale, greenish tinge to the medium. A stormy fermentation in Skim Milk broth is usually conclusive for C. perfringens, but a doubtful reaction should be checked with a Gram stain.

All media described in this section (except Drake's broth) may be obtained commercially from Difco. Use of the various confirmatory and taxonomic test media is not rigid. All laboratories have their own favorite media and procedures for confirming and identifying the pollution indicators described above. Even Lauryl Tryptose or Lactose broth may be substituted for MacC broth if a Brom-Cresol-Purple indicator is added at the rate of 0.01 g per l; although Lauryl Tryptose broth is somewhat more inhibitory than MacC broth, requiring sometimes an extra 24 h to develop a presumptive-positive reaction.

(ii) Interpreting Quantitative and Qualitative Results. Since most laboratories cannot run quantitative analyses for all the indicator bacteria, they may achieve an acceptable compromise by conducting a quantitative analysis for total coliforms with the MF technique; and by testing for the presence of all other indicator bacteria with the P-A method. When the P-A method is employed in conjunction with the MF coliform method, 50 ml sample volumes are used in each test. The P-A procedure, when applied by itself, calls for 100 ml

sample volumes. The following is a recommended procedure for handling results:

1. If the MF plate has a sheen colony count of greater than ten per 100 ml and the P-A bottle shows an acid reaction with or without gas, then the MF count is taken as the final result and the P-A bottle is discarded.
2. If the MF plate produces no sheen colonies, the P-A bottle should be incubated up to four days before discarding. If acid with or without gas occurs, confirmatory tests should ensue to identify the indicator group present.
3. If the MF plate has a sheen colony count, but the 24 h P-A bottle shows little or no reaction, several sheen colonies should be picked off and confirmed. (This type of result is frequently presumptive for Aeromonas organisms.) The P-A bottle should be kept for the remainder of the incubation period in case later presumptive results need confirming.

The above procedures will provide a quantitative result for total coliforms and a qualitative result for all the other indicator bacteria. At least 5 percent of the samples showing no total coliforms by the MF technique will be demonstrated by the P-A test to contain them. Thus, by substituting the P-A test for routine analyses and by applying the MF total coliform test only to random portions (15 - 25 percent) of sample blocks, quantitative data will be available if, at any time, the P-A test results should indicate pollution in part or all of the distribution system. Moreover, since many water suppliers find no total coliforms in 95 percent or more of water samples tested throughout the year, the money expended to run quantitative analyses for each sample may not be justifiable, particularly when the P-A method can provide more information at less cost.

(iii) Generic Distribution of Organisms Isolated from Raw and Finished Water by the P-A Test. Table C.4.g-1 lists organisms recovered from raw and finished surface water samples. Cultures isolated from presumptive positive P-A bottles were identified or characterized according to the scheme in Figure C.4.g-1. Usually 85 percent of these presumptive-positive cultures from both raw and finished

TABLE C.4.g-1

IDENTIFICATION AND RELATIVE FREQUENCY OF CULTURES FROM  
RAW AND DRINKING WATER SAMPLES

Raw Water*		Drinking Water**	
<u>Identification</u>	<u>Frequency</u>	<u>Identification</u>	<u>Frequency</u>
Escherichia coli	40%	Enterobacter cloacae	26%
Klebsiella pneumoniae	17%	Escherichia coli	24%
Enterobacter cloacae	14%	Klebsiella pneumoniae	16%
Aeromonas sp.	11%	Aeromonas sp.	14%
Enterobacter agglomerans	5%	Enterobacter agglomerans	6%
Citrobacter freundii	5%	Citrobacter freundii	5%
Enterobacter aerogenes	2%	Enterobacter aerogenes	2%
Enterobacter hafniae	2%	Ungrouped cultures	2%
Proteus sp., Providencia sp., C. diversus, K. ozaenae, Salmonella sp., Shigella sp., Ungrouped cultures	< 2% each	Proteus sp., Providencia sp., E. hafniae, K. ozaenae, Serratia sp., C. diversus, Salmonella sp., Shigella sp., Yersinia sp.	< 2% each

\* Number of cultures identified from raw water samples were 413.

\*\* Number of cultures identified from drinking water samples were 1,376.

**FIGURE C.4.a-1**  
Scheme for Identification of Cultures from P-A Test

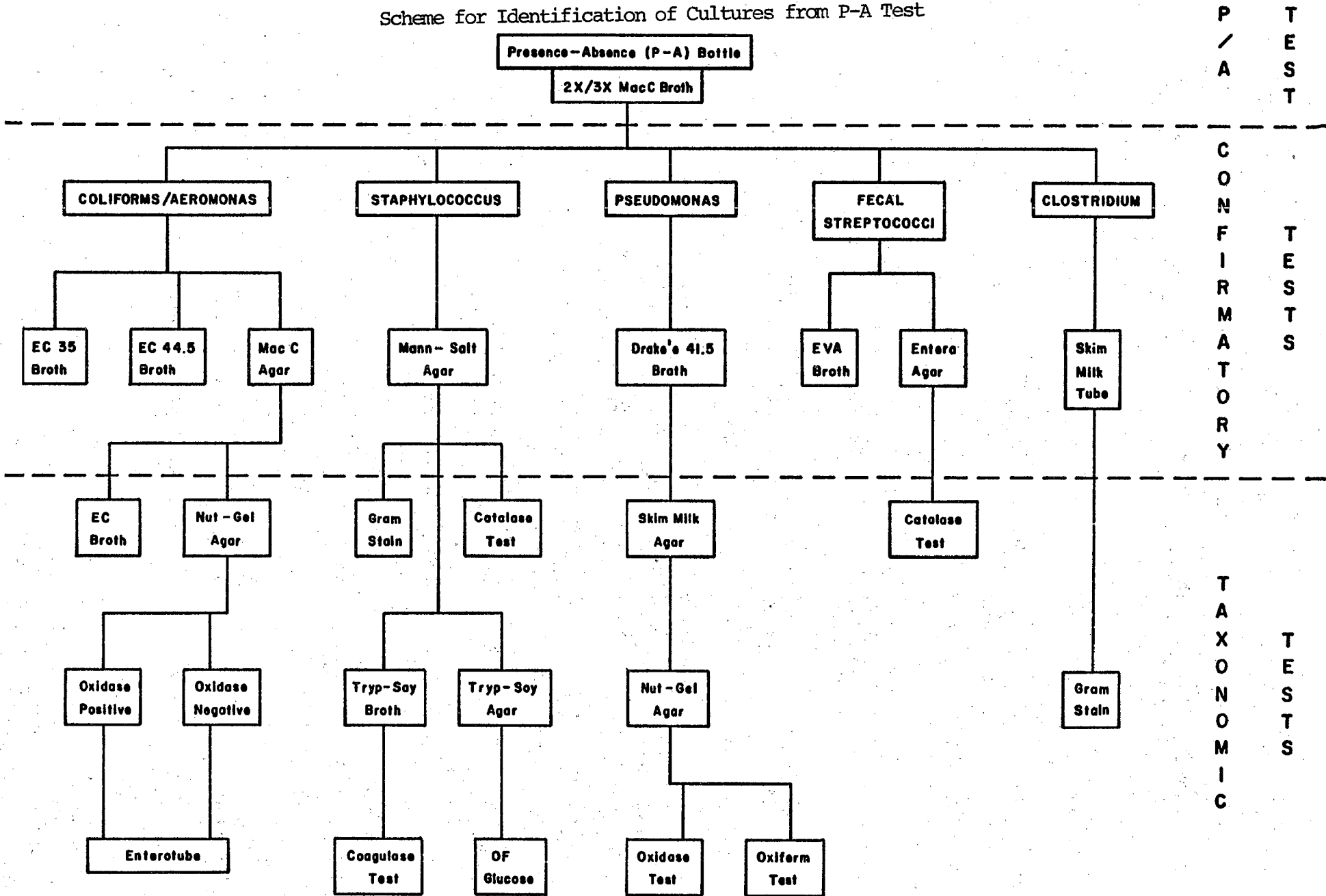

P / A TEST  
 CONFIRMATORY TESTS  
 TAXONOMIC TESTS

water sources proved to be coliforms. Other indicators were recovered less often, their presence being more a function of water source and nature of pollution. Most, but not all, of the colonies isolated from MacC agar plates were lactose fermenters. Those few which didn't ferment lactose, but which predominated on a culture plate, were picked along with the others for identification.

The use of Enterotubes and Oxyferm tubes (Hoffman-La Roche, Ltd.), according to the scheme in Figure C.4.g-1, afforded a more extensive determination of coliform genera. E. coli was most often isolated from raw water samples, but declined the most following water treatment. Alternately, isolation frequencies for other coliforms varied little from raw to finished water sources. While Enterobacter cloacae was more frequently isolated following water treatment, other Enterobacteriaceae were isolated as often from one source as from another.

Though E. coli was most often isolated from raw water samples, it showed the greatest reductions following water treatment. E. coli [See Section C.1.c] has been recognized as the indicator most closely associated with and representative of fecal pollution in drinking water; hence, its presence signifies the potential presence of pathogenic organisms such as Salmonella [See Section C.1.c]. Nonetheless, the results in Table C.4.g-1 demonstrate that though the presence of E. coli indicates fecal pollution, its absence does not necessarily indicate water safety after treatment. In contrast, any of the other coliform genera can be used to measure water treatment efficiency, but not to measure fecal pollution.

Klebsiella pneumoniae [See Section C.2.d] has also been isolated on a number of occasions from drinking water samples and is sometimes the organism responsible for positive fecal coliform tests. Its presence was therefore anticipated, but not in the relatively high numbers and unvaried isolation frequencies noted between raw and drinking water samples. From these results, and in view of the evidence that K. pneumoniae is more often associated with pulp and paper mill and other industrial effluents, its use as an indicator of fecal pollution is not recommended.

Recovery of Aeromonas [See Section C.2.h], also identified in these tests, signifies a deterioration in water treatment or along distribution lines, and it should, therefore, be included as an indicator of water treatment efficiency. However, this organism is often indistinguishable

from coliform colonies when the MF technique is used for analysis. Unless Aeromonas is differentiated, the water will be considered contaminated with fecal pollution, whereas slime deposits in water mains may instead be supporting entrenched Aeromonas populations. This organism is associated with nutrient-rich waters which receive heavy soil run-off's and it is also found as the predominant organism in certain groundwater supplies.

These generic tabulations should not be interpreted to represent all drinking and raw water sources; nor should they be taken to reflect year-round populations. More pollution indicators are detected in summer and fall months when distribution systems carry warmer water which may afford opportunities for regrowth. At other times, pollution indicators will be detected more frequently because of periodic treatment deficiencies at an individual facility. In the event of any such abnormalities, waterworks operators should be alerted so that they may step up disinfection.

(iv) Understanding P-A Test Results. P. aeruginosa [See Sections B.1.a(ix) and C.2.c] and S. aureus are both potential pathogens and their detection is cause for concern, especially since they may be established along portions of the distribution system. Most healthy individuals may not be affected by ingesting small numbers in drinking water, but there may be those who are susceptible to infections by these bacteria.

When fecal streptococci are isolated in association with total or fecal coliforms, the water is probably contaminated with fecal material. However, isolation of fecal streptococci by themselves may indicate marginal treatment of the water supply. Because many species in this group tend to be host specific, proper interpretation may call for species identification.

Staphylococcus epidermidis and Micrococcus species were isolated (Clark, unpublished data) when no other pollution indicators were detected in water samples. They were found to be protected from disinfection by slime deposits in water mains and reservoirs. Their detection may have no sanitary significance, but rather, should signal that some portion of the distribution system needs attention due to deteriorating conditions.

Total coliforms are employed in North America as the primary indicator of finished drinking water quality [See Sections D.2.g and D.3.f]. However, it is useful to make a

distinction between aerogenic and anaerogenic coliforms when discussing water of deteriorating quality. Among the coliform genera, variability exists within each genus, ranging from no fermentation of lactose to fermentation of lactose at 44.5°C with the production of gas. Depending on the length of time and degree of treatment that intestinal organisms have had in water, their physiological reactions could be altered so that they no longer respond exactly as typical strains. The detection of aerogenic coliforms sometimes indicates that the water supply received no treatment, whereas the detection and differentiation of anaerogenic coliforms may indicate unsatisfactory water treatment or insufficient chlorine residuals. The significance of anaerogenic coliforms has not been fully investigated because some MPN procedures do not use a pH indicator and thus, rely mainly on gas production to detect coliforms. MF techniques fail to distinguish non-lactose fermenting variants of the coliform genera, and do not differentiate between aerogenic and anaerogenic variants.

Clostridium perfringens has been shown to occur more frequently in distribution systems during winter and spring when seasonally colder waters reduce the efficiency of chlorine disinfection and aid survival of C. perfringens in the distribution system. This organism has been shown to build up in sand filters whereupon it may detach and be passed along through the distribution system.

When good quality water is delivered through well maintained and disinfected distribution systems, water samples taken from anywhere along the distribution route will be free of the pollution indicators described here. However, if good quality water passes through pipelines and reservoirs which have been allowed to deteriorate, pollution indicators will continue to appear in water samples; albeit, they may be of genera quite different from those usually associated with fecal sources. The point to be emphasized is that because of certain ecological factors in distribution systems, particular types of organisms, whether gram-positive or -negative, may become the resident flora. By using simple, rapid, and reliable test procedures to determine which pollution indicators are becoming established, remedial action can be taken before a crisis develops (Ontario Ministry of the Environment, 1976).

(v) Summary. The P-A test provides a simple, effective means of assessing water quality for the routine surveillance of distribution systems. A full range of



taxonomic tests would not be required on a routine basis, as the confirmation tests specified would be sufficient to assign most of the organisms to one or more indicator groups. Differentiation of the coliform genera, other than E. coli, would not likely be very helpful in determining whether the water was safe to drink. However, if coliforms, aeromonads, or any of the other indicators are detected, with any degree of frequency, in consecutive samples or sample blocks, this signifies problems within the distribution system. Either the walls of water mains are not being adequately protected from slime deposits, or factors such as warmer water and available nutrients are inducing regrowth of such organisms within the distribution system.

h. Membrane Filter Procedure for U.S. Standard Plate Count. The method presented here produces results closely parallel to those achieved with the standard plate count (SPC) used in the U.S. [See Section C.1.a]. The membrane SPC (M-SPC) method is offered as a substitute for the SPC and, as such, would be used (in conjunction with standard coliform analyses) to measure changes in the bacteriologic quality of potable water passing through water supply distribution systems or point-of-use treatment devices.

(i) Advantages of Using Membrane Filters. The M-SPC procedure would have a marked advantage for the enumeration of bacteria in potable waters by allowing the examination of sample volumes larger than one milliliter, thereby drastically increasing the statistical acceptability of results heretofore obtained with the SPC method. A membrane filter procedure would have the additional benefits of savings in time, incubator space, equipment, materials, and labor (Clark, et al., 1951). Also, colony pigmentation develops more readily on the membrane filter, and individual colonies may be easily picked for further identification. The only factors potentially restrictive of this procedure are sample turbidity and spreading of colonies on the filter surface. Colony density on the filter can be controlled by adjusting sample volumes appropriately.

(ii) Medium Preparation and Procedure. The M-SPC medium utilizes a general enriched formulation consisting of three conventional nutrients: peptone, gelatin, and glycerol. It may be obtained, in dehydrated form, from Difco (glycerol must be ordered separately), or prepared in the laboratory [See Table C.4.h-1]. Rehydrate the gelatin, peptone, and agar in distilled water; then heat to

TABLE C.4.h-1

## M-SPC MEDIUM FORMULATION

---

---

Gelatin	25.0 g
Peptone	20.0 g
Agar	15.0 g
Glycerol	10.0 ml
Distilled water	1000 ml

---

---

boiling. Cool to 45 - 50°C and adjust to pH 7.0 with 1 N NaOH. Then, add glycerol and autoclave for 5 min at 121°C. Pour medium into petri plates with tight fitting lids [See Section C.1.b], and store between 2 and 10°C.

An appropriate volume of water sample (100 - 500 ml or more) is passed through a membrane filter [See Section C.1.b], the filter is then placed (taking precautions to avoid trapping any air bubbles) on an M-SPC agar plate. Plates with filters are incubated at 35°C for 48 to 72 h to achieve maximum colony size. An incubation temperature of 35°C is selected, to conform with procedures specified in the U.S., for determining a "standard" plate count in potable water (American Public Health Assoc., 1976). Membranes selected for counting should contain between 20 and 200 bacterial colonies. All colonies are counted with the aid of a wide-field dissecting microscope, 10 - 15X magnification, and recorded as numbers per one milliliter.

(iii) Agreement Between the SPC and M-SPC Methods. The mean SPC/M-SPC ratio for 164 drinking water samples was 1.099, indicating that the two procedures very closely approximate one another (Taylor and Geldreich, in press). In point of fact, the geometric mean ratio was 0.501, revealing the inclusion of a few unusually high ratios in the field data. That is, 120 of the individual samples registered ratios of less than one, indicating that the M-SPC procedure provided higher counts than the SPC procedure approximately 75 percent of the time. It remains to be seen whether results of the two methods will correlate as closely when applied to a greater number and variety of field samples.

(iv) Summary. A membrane filtration method has been developed that gives results closely parallel to those achieved with the U.S. standard plate count. The method is designed to replace the pour plate technique, and as such, to measure changes in the distribution system or in passage through point-of-use water treatment devices. In addition to increased volumes of water that can be tested, the method allows savings of time, space, and equipment. Colony pigmentation develops better on the membrane filter, and the colonies may be easily picked for identification.

i. Epifluorescence -- Total Cell Count. The direct counting of bacteria with a microscope is a technique with a

long history. As traditionally practiced, it has entailed concentrating bacteria by filtering 2 ml of sample water through a membrane. Bacteria trapped on the filter are stained. Then, the filter is dried and rinsed; finally, what are supposed to be bacteria are counted with the aid of transmitted light. Direct counting has never been popular because most bacteria in environmental waters are so small that identifying them from small dots required an act of faith. However, recent improvements in both membrane filters and microscopes have resulted in easier and more reproducible methods of direct counting. The epifluorescence direct count method is a rapid and simple way to determine total numbers of bacteria in water [See Sections C.3.b and C.4.b].

By employing direct counting methods, investigators have observed high numbers of bacteria in all water sources sampled: the Great Lakes and coastal oceanic waters may have about  $10^6$  bacteria per ml (Zimmerman and Meyer-Reil, 1974); mountain lakes or open ocean waters contain about  $10^5$  cells per ml; even distilled water, stored for a month in the laboratory, may have as many as  $10^6$  cells per ml (Daley and Hobbie, 1975). Sewage polluted water has been found to contain as many as  $10^8$  cells per ml (Straskraba and Straskrabová, 1969).

Bacteria will grow in any suitable water, including most distilled water. Rather high numbers of bacteria, over  $10^6$  per ml, have been found in drinking water (although no controls were run for presence of residual chlorine or effects from storage) [See Section G.6]. Bacteria are capable of growth during distribution where finished water does not contain a sufficient chlorine residual. Though generally not hazardous to health, these organisms may cause a number of technical and nuisance problems [See Sections C.4.g, F, and G.2 to 4] and may not be enumerated efficiently using plate count agar.

Most bacteria seen with epifluorescence do not grow well under laboratory conditions, although up to 90 percent of these same organisms are, according to autoradiographic studies, actively taking up substrates (such as sugars and amino acids) from solution (Hoppe, 1976). Therefore, direct counting using epifluorescence can remedy deficiencies in total bacterial enumerations, though it is not specific for pathogens or indicator organisms, and should only be used to supplement or replace non-specific plate count techniques.

(i) Materials for Direct Counting with Fluorescence Microscopy. A variety of dyes have been successfully used for staining samples prior to counting; they all provide adequate contrast, but none is specific for bacteria. Fluorescein isothiocyanate (FITC) has been used (Fliermans and Schmidt, 1975), as has euchrysin (Jones, 1974), but acridine orange (AO) is the most widely accepted (Hobbie, et al., 1977). The usual final concentration is 0.01 percent AO.

Polycarbonate membranes, such as those produced by Nuclepore, have a very flat surface that retains all the bacteria on top of the filter. Although cellulose filters also retain all of the bacteria, many are trapped inside the filter where they cannot be counted. The polycarbonate membranes used in this procedure are 25 mm in diameter and have straight-through cylindrical pores with a diameter of 0.2  $\mu\text{m}$ . A 0.1  $\mu\text{m}$  porosity filter can also be used but at this diameter, the filtering rate is greatly reduced. The filter is stained before use by soaking 2 to 24 h in a solution of 2 g irgalen black (a competitive stain) in one liter of 2 percent acetic acid (Hobbie, et al., 1977).

A variety of microscopes have been used with success. Most manufacturers now make an epifluorescence attachment and have light filters especially for AO (e.g., Zeiss, Leitz, American Optical, Olympus, Nikon). A quartz halogen lamp is satisfactory, but a mercury lamp may give a higher intensity if necessary.

(ii) Method for Direct Counting with Fluorescence Microscopy. A few drops of a fluorescent dye are added to a water sample. It is convenient to place a 2.0-ml subsample in a small test tube and to add 0.2 ml of 0.1 percent AO (in distilled water). After the sample is held for one minute, it is filtered through a polycarbonate membrane. Filtering less than 2 ml does not permit an even distribution over the filter surface; therefore, dilution water may be added so that the total quantity filtered is 2 ml. When bacterial numbers are low, larger sample volumes can be filtered. Placing the polycarbonate membrane on top of a cellulose membrane filter during filtration helps to produce a more uniform distribution of cells.

While still damp, the membrane is placed on a glass slide, and immersion oil is added. Then, a cover slip is put on top, and more immersion oil added. Bacteria are counted,

using epi-illumination, within one hour or several hours (depending on type of water sampled) after preparation.

The epi-illuminated microscope allows a wet filter to be counted because the illuminating light comes from above; it also provides very intense light because the objective lens of the microscope acts as the condenser. As a rough guide, 2 ml of most raw water will yield about 90 bacteria per field when a 90X or 100X objective is used. Usually, one quarter of each of ten randomly chosen fields is counted, for a total of 200 to 400 cells. Because bacteria will readily grow in every kind of water, including distilled water, the numbers found by this technique are likely to be large and may reach  $10^6$  cells per ml.

With this method, bacteria are seen as fluorescent spots against a dark background. In some cases, dividing cells, rods, or spirilla can be seen. However, indicators or pathogens cannot be separated from the abundant naturally occurring bacteria. In most cases, bacteria can be differentiated from debris because bacteria take up more stain (when kept at a relatively low concentration, AO interacts with the nuclear material of bacteria) and appear more regular in shape. That these small brightly fluorescing foci are bacteria was verified by the good agreement of their numbers with scanning electron microscope counts (Bowden, 1977) and with indirect measures of bacteria such as the lipopolysaccharide content of the sample (Watson, et al., 1977)(See Section c.3.a).

The water sample (and the AO too) can be preserved with formaldehyde at a final concentration of 2 to 4 percent and stored for at least two months. Permanent slides can be produced with the Zimmermann (1977) technique.

(iii) Potential Applications for Use with Drinking Water. Epifluorescent direct counts have not been used on finished drinking water. However, this method offers potential for use in tracing breaks in supply systems, or in monitoring the overall quality of water supply sources. Pollution in a water supply may cause an increase in total cell numbers of 10 to 100 times.

By conducting a series of studies of bacterial numbers at different points in the treatment and distribution system, waterworks microbiologists could determine general levels and employ epifluorescence counting for quick assessment of the quality of water. Likewise, this technique could be

used for rapid tracing of breaks in lines and other similar emergencies. Further evaluation of this type of application is recommended.

Another possible approach could be based, not on total numbers of bacteria, but on the size of individual cells. Most bacteria in unpolluted waters are tiny, 0.2 to 0.4  $\mu\text{m}$  in diameter, whereas bacteria in extremely productive or organically polluted waters grow to diameters of up to 1  $\mu\text{m}$ . Whether a richer nutrient source brings about increased sizes in the initial flora, or whether different organisms predominate under polluted conditions, is not yet known.

(iv) Summary. Bacteria in water can rapidly be counted (within 15 minutes of sampling) by staining with a fluorescent dye such as acridine orange, concentrating by filtration through a polycarbonate membrane, and viewing with an epifluorescent microscope. Because the technique is not specific for indicator or pathogenic organisms, it can be used only to supplement or replace non-specific plate count methods used for investigating the quality of finished water. It may be valuable for monitoring the quality of supply waters or for obtaining rapid analyses of line breaks or other emergency situations.

## 5. Summary

The indicator systems in this section are extremely varied, ranging from fecal indicators and pathogens to biomass estimates, including new, faster, and automated methods to increase speed and sampling efficiency. It is clear that not all of these organisms or techniques have the same health and sanitary significance, nor are they all applicable to the same types of waters.

It seems evident that the "classical" fecal indicator organisms have served rather well in preventing transmission of human disease by drinking water and shall continue to be used for some time to come. Total coliform enumeration, for example, is of limited value in the determination of raw water quality, but is a sensitive method for determining finished water quality and treatment adequacy. Total coliforms in drinking water do not necessarily reflect fecal contamination, but their presence should alert the responsible agency to a possible problem, and action can then be taken to find the cause and correct it as necessary. Thermotolerant coliforms (fecal coliforms) or Escherichia coli and Clostridium perfringens, on the other hand, can be employed for both raw and finished drinking water. The presence of

any of these organisms in finished water should be an immediate cause for concern and should be followed by resampling and corrective measures. Their level in the raw water is generally considered valuable in determining the type and degree of treatment required. Obviously, the greater the degree of contamination of the raw water, the more safeguards (perhaps both intensified treatment and stepped-up testing of the finished water) will be required to protect the consumer. Clostridium perfringens is a particularly hardy organism because of its ability to form disinfectant-resistant spores; it may thus be of value in determining the adequacy of water treatment and filtration. Fecal streptococci are of limited value in monitoring finished water quality, except when gross contamination occurs, but are used extensively for raw water. The judicious use of this indicator can greatly assist in determining the source, distance, and time of pollution of the raw water, when the studies are done in conjunction with other indicators such as thermo-tolerant coliforms.

Since this group of fecal pollution indicators is so important and routinely used, any procedural modification that reduces cost, speeds up the analysis, or reduces the labor involved is considered an improvement. For this reason, the 7-h membrane filtration fecal (thermo-tolerant) coliform test appears to be a valuable method, especially for emergency use, such as when finished drinking water is found to be polluted as a result of main breaks or cross contamination with sewage pipes. The presence-absence test is applicable to finished water only; it quickly and cheaply screens out all coliform-free samples, so that the positive samples can be given more detailed analysis. Both the automated sampling and plating methods and the automated plate counting methods could be applied in specific settings for these organisms. At present, they are not widely used, but further improvements in automation and data handling, as well as the increased costs for personnel to carry out routine analyses, will eventually make them more attractive. Other methods presented here, that show potential for thermo-tolerant coliform indicators, are radioisotope methods, impedance methods, and enzymatic methods. Each of these has been tested to a limited extent, to determine levels of coliforms or Escherichia coli and may have more widespread application in the future. They represent the application of physical and chemical technology to the field of drinking water microbiology, an endeavor that must be encouraged.

The analysis of fecal sterols is emerging as a promising indicator that eliminates some of the drawbacks of fecal



bacteria indicators. The fecal sterols display many adsorption and elimination properties similar to viruses and bacteria, but additionally, are not affected by most disinfection processes, by elevated temperatures, nor by toxic effluents. Further work is required to determine their ultimate applicability.

Certain other organisms are considered here, as indicators, because of their applicability in certain problem areas and their properties as pathogens or opportunistic pathogens of susceptible humans. Pseudomonas, Klebsiella, and Aeromonas are common opportunistic pathogens in water and are able to multiply under relatively low nutrient conditions, sometimes causing problems in the distribution system. It is worthwhile to monitor for these organisms occasionally, or when there is a known problem. Their health significance in low numbers in finished water is not well established, but their presence indicates potential problems in the treatment or distribution system and should stimulate more intensive sampling and investigation. The presence of Klebsiella in raw waters is often the result of its growth in carbohydrate-enriched waters, and its effect as a positive bias on total coliform and thermo-tolerant coliform counts is well known. Vibrios are becoming increasingly important as pathogens in the marine and estuarine environment, as is Candida albicans in the fresh-water environment; both warrant further study in reference to drinking water quality. Bifidobacteria show extremely good promise as a fecal indicator and are receiving increasing attention; the problem at this time is the lack of adequate methods for measuring them.

In addition to the presence of fecal material and human pathogens in water, there is concern for the general bacterial population in tapwater. General bacteria are usually present in much larger numbers, in both raw and finished waters, than organisms of health and sanitary significance, and they may have important consequences. First, when present at levels greater than 500 per ml, they greatly diminish the ability to detect total coliforms in the water, thereby adversely affecting the accuracy of that method. Second, increases, particularly sudden ones, in total bacterial colony counts may signal a change in water treatment efficacy, distribution problems, or other sources of contamination even before the traditional fecal indicators can signal such a change. They are also useful to determine bacterial growth in point-of-use water treatment devices. Plate count methods vary as to procedure, media, and incubation temperature; a new membrane filter method is described

that is more versatile and economical than some of the pour-plate or spread-plate methods. Two other possible mechanisms exist to determine numbers of bacteria in water: direct counting and biochemical measurements. The epifluorescence method has the distinct advantage of being very fast and can be particularly useful in emergency situations. Among the biochemical methods, measurement of ATP is probably the one most often used, although concentration methods are required for low bacterial levels in finished drinking water. The Limulus lysate assay is much more sensitive, and can easily detect the low levels of lipopolysaccharides derived from the cell walls of gram-negative bacteria in tapwater. Further research is required to ascertain how these methods relate to the more common plate count methods.

The problem of an adequate indicator system to signal the presence of human enteric viruses in water is one that has not been resolved. Bacteriological indicators of fecal pollution are not always adequate for this purpose because of the greater ability of viruses to resist environmental extremes and disinfection processes. Concentration, elution, and cell culture techniques do not exist for all of the viruses known to be transmitted in water, so it is impossible to detect them all even if it were economically feasible to do so. Vaccine polioviruses are a logical enteric virus indicator because of their relative abundance in waters in areas where trivalent oral polio vaccine is used. Present data leave some doubt, however, as to the adequacy of polioviruses for this purpose, for they are not detected in waters with the frequency that would be predicted on the basis of the numbers of persons excreting them. Coliphages, on the other hand, are found in much larger numbers and are not dependent upon the use of vaccines in the population. The ideal host for this method, and the actual relationship between the occurrence and survival of these bacterial viruses and human viruses is still open to question. Thus, until the basic question of virus indicators is settled, routine analysis of drinking water for fecal pollution indicator bacteria and the maintenance of sound water treatment and disinfection practices must be relied upon to ensure the virological quality of the water.

The list of indicator systems considered here is not exhaustive; there are many others that could have been included. Some of those selected, however, are among those most firmly established, others are among the most promising, and still others are among the most interesting. It becomes

evident very early that even though the field of water microbiology is by no means new, there is still no best indicator system for every situation, nor is there ever likely to be one. Each situation may require one or several microbiological tests that can be selected from the ever-changing array of indicator systems.

## 6. Recommendations

1. Colony counts should be used in conjunction with total coliforms to assess finished water quality and to monitor for any changes in water quality along the distribution system. A limit of 500 colonies per ml at 35°C should be considered for finished water, to reduce problems with detection of total coliforms due to interference from non-coliforms.
2. Membrane filtration media for total coliform enumeration should be developed to replace those requiring the dye, basic fuchsin, in view of the impending shortage of this dye.
3. Membrane filter methods for detecting Escherichia coli should be improved to permit faster and simpler enumerations with disinfected water.
4. Better selective media and methods should be developed for recovery of bifidobacteria in raw and finished water. Bifidobacterium should be studied, extensively, in its role as a fecal indicator.
5. Studies should be carried out to determine sources of Candida albicans (e.g., humans, birds, animals, etc.). Also needed are studies to determine the survival rates of C. albicans in water treatment and disinfection processes. In addition, the relationship, if any, between densities of C. albicans and classical indicators should be determined. Finally, the role of sediments in concentrating C. albicans in drinking water collection basins and other receiving waters should be evaluated.

6. The significance to human health of vibrios present in raw source waters should be determined.
7. Attention should be given to the use of immobilized enzymes and other rapid methods for determining adenosine triphosphate (ATP) levels.
8. Studies should be carried out to determine the mechanism by which coprostanol is degraded in water and what the effects are from environmental factors. Coprostanol persistence and baseline levels in surface waters and sediments should be determined.
9. The impedance method should be further refined to make it sufficiently sensitive and fast for on-line analysis of finished water.
10. Automated sampling and plating devices should be improved to enable detection of anaerobic sporeforming organisms. Concentrators for these devices need to be developed so that assays may be sensitive enough for use with finished water.

#### D. TESTING AND STANDARDS

Tests to assess the microbiological quality of drinking water rely largely on the recovery or enumeration of coliform bacteria, thermo-tolerant coliform bacteria, or Escherichia coli and, in some instances, aerobic heterotrophic bacteria. Formal standards of drinking water quality usually are based on numerical values derived from specified test procedures. While it may be assumed that coliform or thermo-tolerant coliform bacteria are identical and unaffected by national boundaries, differences in test procedures may produce differences in results because, in part, the definitions are functional and depend on the analytical procedures used. To evaluate these differences, a survey was conducted among the participant nations to identify analytical techniques and water quality standards. To simplify the data gathering and reporting and to make possible direct comparisons in definitions and techniques, the information has been summarized in a series of tables [Tables D-1 to D-6]. Although these tables are largely self-explanatory, some general comments are necessary.

The questionnaire was prepared in English and was keyed to the practices used in the U.S. as described in Standard Methods (American Public Health Association, 1976). This led to some difficulties of interpreting the questions and may have resulted in inappropriate responses. One major area in which this problem consistently occurred was that of quality assurance. The term quality assurance usually is understood as an assessment, statistical or otherwise, of the quality of the product. What was not clearly understood was the nature of the product. Thus, some respondents dealt with water quality as indicated by standards, while others responded in terms of quality control within the laboratory. Although it was intended that this latter subject be addressed, it frequently was not. Irrespective of the information provided herein, it is clear that control of personnel, procedures, materials, etc. in the laboratory, is of paramount importance, but often is not dealt with officially. Excellent

guides to quality assurance practices in health laboratories in general (Inhorn, 1978) and in drinking water laboratories (Environmental Protection Agency, 1978) are available.

An additional difficulty lies in the occasional absence of a formal national methodology or in the failure of some laboratories to conform to the national methodology. This problem is compounded by the continuing evolution of laws and regulations so that changes in procedures are constantly underway. Hopefully, the tables summarize the officially accepted techniques whether or not they are in current use.

### 1. Sampling and Sample Storage

Table D-1 summarizes the data obtained for sampling frequency, sample size, and sample storage. Generally, sampling of both raw and treated water is not required (except in the Netherlands, Norway, and Sweden), and primary control of bacteriological quality of water is attempted through collecting and analyzing samples from distribution systems. Typically, the required frequency of sampling is a function of the population served or the volume of water distributed by a water system. The required sample size varies from 50 to 800 ml with the average being about 200 ml. Although many European countries require refrigeration of water samples not analyzed within 3 to 4 h, this is not mandatory in Canada unless sample transit times exceed 24 h, nor in the U.S., where ambient water temperature is acceptable provided no sample awaiting analysis exceeds a 30 h limit. Replies to the questionnaire indicated a consensus of opinion that a temperature above freezing, but less than 10°C, probably is adequate. Despite the recognition that holding samples, even though they may be chilled, may affect the bacteriological content of the samples [See Sections E.1 and G.6], storage of up to 36 h (Sweden) is permitted. Problems of sample transport clearly influence the maximum holding time and every effort must be made to keep the time to a minimum.

### 2. Total Coliform Testing, Membrane Filter Technique

Table D-2 summarizes the data obtained with respect to the definition of total coliform bacteria and the analytical details used for the membrane filter technique. Two types of definitions are used: one is based on specific physiological and morphological characteristics of the organisms (aerobic or facultatively anaerobic, rod-shaped, gram-negative, nonsporeforming); the other definition is based directly on the analytical technique used (organisms producing a typical sheen on a defined medium). Some definitions,

TABLE D-1

## SAMPLING AND SAMPLE STORAGE, DRINKING WATER ANALYSIS

	Canada	Denmark	FRG	France	Greece	Israel <sup>2</sup>	Italy
1. Frequency of required sampling							
a. Raw water	As required by control agency <sup>1</sup>	As required <sup>1</sup>	Voluntarily by producer <sup>1</sup>	As required <sup>1</sup>	Not specified <sup>1</sup>	As required <sup>1</sup>	--
b. Treated water	See c.	See c.	See c.	See c.	Not specified <sup>1</sup>	As required <sup>1</sup>	--
c. Distribution system	At least 4x/month, depending on population served (Table & figure available)	At least 1x/year, depending on population served	Undisinfected: 1/30,000 m <sup>3</sup> distributed; Disinfected: 1/15,000 m <sup>3</sup> distributed	At least 3x/year; up to 1x/day for large supplies	At least 1x/month, depending on population served (Table available)	As required	--
d. Other	--	--	--	--	--	--	--
2. Sample size, ml	> 100	> 500	about 250 <sup>1</sup>	> 350	200	100, 200	200

TABLE D-1 -- Continued

	Netherlands	Norway	Spain	Sweden	UK	US
1. Frequency of required sampling						
a. Raw water	1x/4 weeks	As required	Large systems 1x/day; small systems 1x/month	Groundwater 1x/year; surface water 4x/year	Large systems (> 10,000) 1-2x/week	Not required <sup>1</sup>
b. Treated water	Groundwater 1x/week; surface water 1x/day	Large systems (> 10,000) 3x/wk; medium systems (5,000-10,000) 2x/wk; small systems (1,000 - 5,000) 1x/wk, (< 1,000) 1x/month	See a.	Large systems (> 4,000) 1x/week; small systems 1x/month	Large systems 5x/week; small systems 1x/week at least	Not required <sup>1</sup>
c. Distribution system	1x/week	Same as for treated water	See a.	Not required	At least 1x/week, depending on population served (Table available)	At least 1x/3 months, depending on population served (Table available)
d. Other	--	--	--	--	--	--
2. Sample size, ml	250-500	2 x 250	200-300	800	228	MF <sup>3</sup> 100 MPN <sup>4</sup> 5 x 10 or 5 x 100



TABLE D-1 -- Continued

	Canada	Denmark	FRG	France	Greece	Israel <sup>2</sup>	Italy
3. Maximum storage time, hours	24	24	3, if refrigerated 24-30 h	8	12	3, 0.5	6
4. Storage temperature, °C	Refrigerate if stored > 24 hours	0-5	about 4	4-6	about 4	ambient, 4-10	4

TABLE D-1 -- Continued

	Netherlands	Norway	Spain	Sweden	UK	US
3. Maximum storage time, hours	24	3, if refrigerated 30	8	4 h, if refrigerated at < 10°C 36 h	6	30
4. Storage temperature, °C	0-4	2-10	2-4	< 10	4	ambient 0-10

<sup>1</sup>Not legally specified.

<sup>2</sup>Israel reported results for Public Health Lab., Tel Aviv and National Water Co.

<sup>3</sup>MF = Membrane filter procedure.

<sup>4</sup>MPN = Most probable number or multiple tube dilution procedure.

TABLE D-2

## TOTAL COLIFORM TESTING, MEMBRANE FILTER TECHNIQUE, DRINKING WATER ANALYSIS

	Canada	Denmark	FRG	France	Greece <sup>1</sup>	Israel	Italy
1. Total coliform bacteria, define	Aerobic and facultative anaerobic, gram-negative, non-sporeforming cytochrome-oxidase negative, rod-shaped bacteria producing colony with golden green metallic sheen in 24 hours on Endo-type medium containing lactose	Bacteria producing yellow colonies at 37°C & biochemically & morphologically similar to <u>E. coli</u>	Gram-negative, cytochrome-oxidase negative, non-sporeforming rod-shaped bacteria producing acid & gas from lactose or producing red colonies on Endo agar after 24 h at 37°C	Ferment lactose with formation of gas (See ISO definition)	Not legally specified (See definition in <u>Standard Methods, American Public Health Assoc., 1976</u> )	Not legally specified (See definition in <u>Standard Methods, American Public Health Assoc., 1976</u> )	Not applicable
2. Samples							
a. Volume filtered filter, ml	> 100	100	100	100 or 50	100, 50	100	
b. Number of replicated/sample	Not required	Not required	Not required	Not required	Not required	Not required	
c. Are diluted samples analyzed	Not routinely	Not routinely	Routinely, if necessary	Not routinely	Not routinely	Not routinely	

TABLE D-2 -- Continued

	Netherlands	Norway	Spain	Sweden	UK	US
1. Total coliform bacteria, define	Facultative anaerobic, gram-negative, non-sporeforming rod, producing acid and gas in lactose medium at 37°C in 48 hours	Dark red colonies with or without fuchsin sheen	Not legally specified (dark colonies with metallic sheen)	Not applicable	Gram-negative, oxidase negative non-sporing rods growing aerobically on agar containing bile salts and fermenting lactose within 48 hours at 37°C producing acid and gas	Organisms producing golden green metallic sheen
2. Samples						
a. Volume filtered/filter, ml	100	100	100		50 or 100	100
b. Number of replicated/sample	Not required	2	2		Not required	Not required
c. Are diluted samples analyzed	Not routinely	Not routinely	Yes, if highly contaminated		Yes, if highly contaminated	Not routinely

TABLE D-2 -- Continued

	Canada	Denmark	FRG	France	Greece <sup>1</sup>	Israel	Italy
3. Dilution water, if used, specify formula	--	Phosphate buffer (3 g $K_2HPO_4$ & 1 g $KH_2PO_4/1$ )	Normal saline or tap water	Distilled water or Ringer's 1/4x	Ringer's solution 1/4x		
4. Membrane filter							
a. Filter diameter, $\mu m$	47	47	50	47	47	47	
b. Pore diameter, $\mu m$	0.45	0.45	0.45	0.45	0.45	0.45	
c. Sterilization							
Autoclave - time & temperature	10 min at 121°C	Purchase sterile	Purchase sterile or boil for 20 min in distilled water	Purchase sterile or autoclave or boil for 20 min	Purchase sterile	Purchase sterile or U.V.	

TABLE D-2 -- Continued

	Netherlands	Norway	Spain	Sweden	UK	US
3. Dilution water, if used, specify formula	0.1% peptone water	Not specified	Phosphate water (1.25 ml/l of 34% solution of $\text{KH}_2\text{PO}_4$ )		Ringer's solution 1/4x	Phosphate buffered distilled water or 0.1% peptone water
4. Membrane filter						
a. Filter diameter, um	47	47	47-50		47	47
b. Pore diameter, um	0.45	0.45	0.45		0.45	0.45
c. Sterilization						
Autoclave - time & temperature	Purchase sterile or boil	Boil for 5-10 min	10 min at 120°C		Boil in sterile distilled water 10-15 min	10 min at 121°C

TABLE D-2 -- Continued

	Canada	Denmark	FRG	France	Greece <sup>1</sup>	Israel	Italy
<b>5. Media</b>							
<b>a. Single step procedure</b>							
Liquid medium	M-Endo broth		--	--	0.4% Teepol broth or M-Endo broth	M-Endo broth	
Solid medium	LES-Endo agar	Teepol agar (Burman)	Endo agar	Chapman modified by Buttiaux	--	--	
<b>b. Enrichment procedure</b>							
Enrichment liquid medium	Lauryl tryptose broth	--	--				
Enrichment solid medium	--						
Final liquid medium	M-Endo broth						
Final solid medium	LES-Endo agar						
<b>c. Sterilization - time &amp; temperature</b>							
	Lauryl tryptose: 121°C for 15 min Endo broth or agar: heat to boiling	110°C for 15 min		120°C for 20 min	Steaming for 30 min on 3 consecutive days or boiling	Heat to boiling	

TABLE D-2 -- Continued

	Netherlands	Norway	Spain	Sweden	UK	US
<b>5. Media</b>						
<b>a. Single step procedure</b>						
Liquid medium	--	M-Endo broth or Sartorius dehydrated Endo pads	M-Endo broth		0.4% Teepol broth	M-Endo broth
Solid medium	0.4% enriched Teepol agar	M-Endo agar or Endo LES agar			--	LES-Endo agar
<b>b. Enrichment procedure</b>						
Enrichment liquid medium	--	--	--		--	Lauryl tryptose broth
Enrichment solid medium						--
Final liquid medium						M-Endo broth
Final solid medium						LES-Endo agar
<b>c. Sterilization - time &amp; temperature</b>						
	121°C for 15 min	Heat to boiling and cool immediately to 45-50°C	Heat to boiling		Steaming for 30 min on 3 consecutive days	Lauryl tryptose: 121°C for 15 min Endo broth or agar: heat to boiling



TABLE D-2 -- Continued

	Canada	Denmark	FRG	France	Greece <sup>1</sup>	Israel	Italy
<b>6. Incubation</b>							
<b>a. Single step procedure</b>							
Time (hours), temperature (°C)	22-24, 35 ± 0.5°	24 & 48 37 ± 0.1°C	20 + 4, (but observe up to 44 + 4 h); 37 ± 0.5°C	24 (21-25), 37°	4 hr at 30° then 14-16 hr at 35-37°	20-24, 35 ± 0.5°	
<b>b. Enrichment procedure</b>							
Enrichment: time, temperature	1.5 hr, 35 ± 0.5°	--	--	--	--	--	
Final step: time, temperature	20-22 hr, 35 ± 0.5°						

TABLE D-2 -- Continued

	Netherlands	Norway	Spain	Sweden	UK	US
<b>6. Incubation</b>						
<b>a. Single step procedure</b>						
Time (hours), temperature (°C)	6 hr at 25° then 12 hr at 37°	24 ± 3, 37 ± 0.5°	24 35 ± 0.5°		4 hr at 30° then 14 hr at 35° or 37°	22-24, 35 ± 0.5°
<b>b. Enrichment procedure</b>						
Enrichment: time, temperature	--	--	--	--	--	1, 5-2 hr, 35 ± 0.5°
Final step: time, temperature						20-22 hr, 35 ± 0.5°

TABLE D-2 -- Continued

	Canada	Denmark	FRG	France	Greece <sup>1</sup>	Israel	Italy
<b>7. Counting and reporting</b>							
a. Appearance of coliform colony	Golden green, metallic sheen	Yellow	Flat, red or with metallic sheen	Yellow or orange or brick with yellow halo in medium	Teepol: Yellow Endo: Metallic sheen	Metallic or dark sheen	
b. Visual aids used	10-15 x binocular wide-field dissecting microscope	--	--	Hand lens (8x)	Stereoscopic microscope	Hand lens	
c. Units of reporting results	No/100 ml	No/100 ml	Coliforms present or absent /100 ml; number/100 ml	No/100 ml	No/100 ml	No/100 ml	

TABLE D-2 -- Continued

	Netherlands	Norway	Spain	Sweden	UK	US
7. Counting and reporting						
a. Appearance of coliform colony	Yellow	Dark red, with or without metallic sheen	Dark, metallic sheen		Yellow	Golden green, metallic sheen
b. Visual aids used	--	Hand lens	10x		Hand lens	10-15 x binocular wide-field dissecting microscope
c. Units of reporting results	No/100 ml	No. of colonies and average of 2 replicates/100 ml	No/100 ml		No/100 ml	No/100 ml

TABLE D-2 -- Continued

	Canada	Denmark	FRG	France	Greece <sup>1</sup>	Israel	Italy
<b>8. Coliform verification</b>							
a. If required, frequency	Not required	Not required	Yes, all samples	Not required	Not required	Not required	Not required
b. Verification procedure	--	--	Cytochrome oxidase; lactose fermentation at 44 ± 0.5°C in 20 ± 4 hr; utilization of citrate	Treated water: check yellow colony for fermentation of glucose and lactose, oxidase negative, and gram-negative	Transfer to glutamate or MacConkey broth (48 hr at 37°); transfer positive acid and gas to MacConkey agar; typical, gram-negative = coliform	Transfer atypical colonies to MacConkey or violet red bile agar; red colonies = coliforms	
c. Adjustment of results per verification	--	No	Yes, only verified results reported	No	No	Yes, add number of verified colonies	

TABLE D-2 -- Continued

	Netherlands	Norway	Spain	Sweden	UK	US
<b>8. Coliform verification</b>						
a. If required, frequency	Yes, if yellow colonies present	Not required except for new sample sites with atypical colonies	Not required		Yes, for treated water	Yes, 5 or more colonies/filter with > 5 colonies
b. Verification procedure	Transfer 5 colonies to 2% brilliant green bile broth; gas = coliforms	--	Check dark colonies with metallic sheen for <i>E. coli</i> (See Table 4)		Transfer to 1% lactose-peptone and incubate at 37° for 48 hr; transfer to nutrient agar; acid and gas, oxidase negative = coliform	Transfer to lauryl tryptose broth; incubate 24-48 hr at 35 + 0.5°; transfer to brilliant green bile broth, 24-48 hr at 35 + 0.5°; gas = coliform
c. Adjustment of results per verification	No, no coliforms permitted	--	--	--	Yes, reduce counts according to results	Yes, but procedure not specified

TABLE D-2 -- Continued

	Canada	Denmark	FRG	France	Greece <sup>1</sup>	Israel	Italy
9. Water quality standard, specify	< 10/100 ml, 90% of samples in 30 days negative, no coliforms in 2 consecutive samples, no fecal coliforms	Coliforms should be absent in 100 ml	Coliforms should be absent in 100 ml (recommended); no <u>E. coli</u> /100 ml (mandatory)	Untreated water: coliforms should be absent; no <u>E. coli</u> ; treated water: no coliforms	Unchlorinated: 50% of samples/month < 1/100 ml; 80% < 2/100 ml; none > 10/100 ml; chlorinated: < 1/100 ml	See Table 3	

1

Membrane filter technique not legally specified

TABLE D-2 -- Continued

	Netherlands	Norway	Spain	Sweden	UK	US
9. Water quality standard, specify	No coliforms/100 ml	Undisinfected surface water: good < 1/100 ml; not fit for use > 30/100 ml; disinfected surface water; good < 1/100 ml; not fit for use > 2/100 ml; in a year 80% of samples should be good	No <u>E. coli</u> /100 ml; coliforms: good < 2/100 ml tolerable > 2 - < 10/100 ml unsuitable > 10/100 ml		Treated water: no coliforms/100 ml; in practice, the standard is not always obtainable in the distribution system, and the following standards apply: in a yr, 95% of samples coliform free; no samples > 10/100 ml; no coliforms in 2 successive samples	1/100 ml as arithmetic mean, 4/100 ml in < 1 sample if < 20 samples/month; 4/100 ml in 5% of samples if > 20 samples/month



additionally, include the negative cytochrome-oxidase reaction (Canada, FRG, and U.K.). Other definitions are derived from liquid enrichment culture procedures that specify the production of gas or acid and gas from a medium containing lactose (FRG, France, Netherlands, and U.K.). Irrespective of the formal definition, all countries generally have a common understanding of the term total coliform bacteria.

Sample size is relatively uniform at 100 ml, although 50-ml samples are occasionally specified or permitted. With two exceptions (Norway and Spain), analysis of replicate sample portions is not required and diluted samples are not routinely analyzed. In the event that sample dilutions were necessary, as would occur with highly contaminated raw or untreated waters, there is no consensus with regard to type of diluent used. Distilled water, tapwater, normal saline, Ringer's solution at 1/4 normal strength, 0.1 percent peptone water, or phosphate buffered distilled water are all used.

The membrane filter itself is relatively standardized at a diameter of 47 or 50 mm with a pore diameter of 0.45  $\mu\text{m}$ . It is most commonly purchased sterile; if not, it is boiled for 5 to 20 min or sterilized by autoclaving for 10 min at 121°C.

With only one exception (Canada), every country uses a single-step rather than a two-step (enrichment and transfer to final medium) procedure. The single-step medium may be liquid (M-Endo broth or 0.4 percent Teepol broth) or solid (LES Endo agar, Endo agar, Chapman agar, or 0.4 percent Teepol agar). In the two-step procedure, which is seldom used in drinking water testing, lauryl tryptose is used as the enrichment medium. Media are sterilized by steaming for 30 min on three consecutive days (Greece and U.K.), heating to boiling (for M-Endo broth) or autoclaving at 120 to 121°C for 15 or 20 min. Incubation, most commonly, is for 20 to 24 h at 35 or 37°C, although several countries use two-step incubation (Greece and U.K. -- 4 h at 30°C, then 14 to 16 h at 35 to 37°C; Netherlands -- 6 h at 25°C, then 12 h at 37°C).

The specified appearance of the coliform colony is a function of the medium used. For Endo-type media, a metallic sheen and/or a red color is required; with Teepol media, coliform colonies appear yellow; and with Chapman agar, coliforms appear yellow to orange. Colonies on membranes

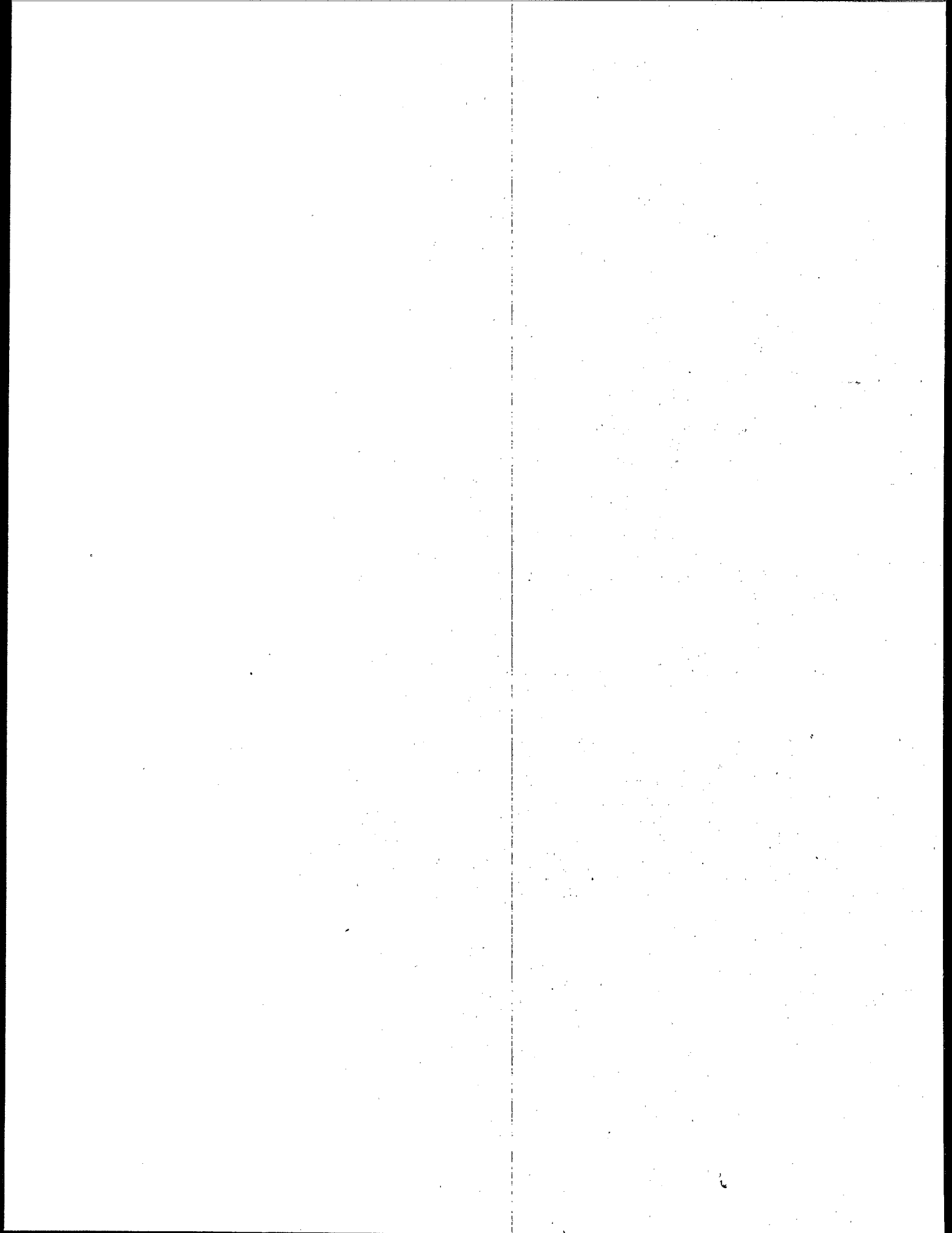

may be examined with or without magnification. Results uniformly are reported as a number per 100 ml.

Verification of coliform colonies is interpreted by the use of additional tests such that the colony identified as a coliform on the membrane filter conforms to the above definition of coliform bacteria, except where the practice is to confirm the colony as E. coli which has a different significance. The simplest procedure for verifying coliforms involves transfer to lactose-containing media (lauryl tryptose broth and/or brilliant green bile broth) and the demonstration of gas after up to 48 h incubation at 35 to 37°C. Lauryl tryptose broth and brilliant green bile broth are not used for coliform verification in the U.K., on the premise that an inhibitory agent is unnecessary where the inoculum is from a single (and presumably pure) colony. More involved techniques include determination of cytochrome-oxidase activity and citrate utilization as well as gram stain. Verification usually is not required.

The criterion for the bacteriological acceptability of water is the absence of coliform bacteria (in 100 ml) [See also Section C.1.b]. Because of procedural and statistical complications, this is variously stated as < 10 coliforms per 100 ml, < 1 coliform per 100 ml, etc. Most countries include in their standard the sampling frequency, how frequently coliforms are found, and an absolute coliform number. The membrane filter procedure is not formally specified in several countries (Greece, Israel, Italy, and Sweden) and appears not to be used officially in Italy and Sweden (Sweden has proposed its use as an official procedure).

### 3. Total Coliform Testing, Multiple Tube Technique

Table D-3 parallels Table D-2 for total coliform testing, but by the older multiple tube technique rather than the newer membrane filter procedure. The definitions of coliform bacteria are comparable to those given in Table D-2, but are restricted to organisms producing gas or acid and gas from a medium containing lactose.

The simpler procedures require testing of five 10-ml or five 100-ml portions of the sample (Canada and U.S.). All other countries use various combinations of sample volumes and tubes per dilution such as ten 10-ml, five 1-ml and one 0.1-ml portions (France); five 10-ml, one 1-ml, and one 0.1-ml portions (Israel); and five 100-ml, five 10-ml, and five

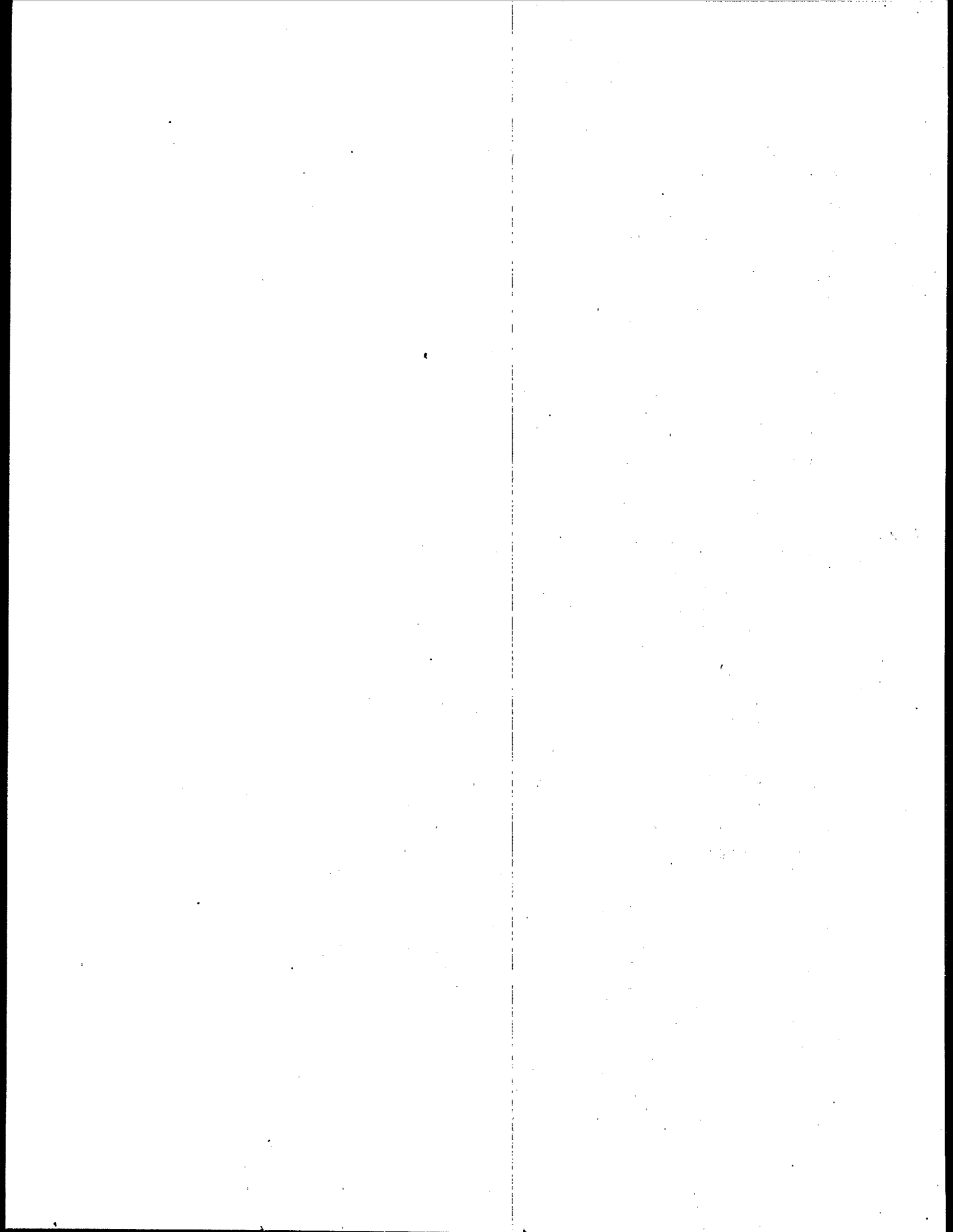

TABLE D-3

## TOTAL COLIFORM TESTING, MULTIPLE TUBE TECHNIQUE, DRINKING WATER ANALYSIS

	Canada	Denmark	FRG <sup>2</sup>	France <sup>2</sup>	Greece	Israel	Italy
1. Total coliform bacteria, define	See Table 2	Bacteria producing gas from lactose in 48 h at 37°C that have biochemical & morphological similarity to <u>E. coli</u>	See Table 2	See Table 2	See Table 2	See Table 2	Organisms producing gas from lactose in lactose broth in 24/48 hours at 37°C and in brilliant green lactose bile broth in 24/48 hours at 37°C
2. Samples							
a. Volume/tube, ml	10 or 100	(1 x 50 ml (5 x 10 ml (5 x 1 ml	100	(10 x 10 ml (5 x 1 ml (1 x 0.1 ml (1 x 0.01 ml (1 x 0.001 ml	(10, 1, 0.1 ml in either a 5-tube or 3-tube replicate series	(5 x 10 ml (1 x 1 ml (1 x 0.1 ml (	(5 x 10 ml (5 x 1 ml (5 x 0.1 ml (
b. Tubes/sample	5		Not specified	(	(	(	(
c. Are diluted samples analyzed	No	Not routinely	Yes, if necessary	Yes	Not routinely	No	No

TABLE D-3 -- Continued

	Netherlands	Norway	Spain	Sweden	UK	US
1. Total coliform bacteria, define	See Table 2	Aerobic facultatively anaerobic, gram-negative, non-sporeforming rod-shaped bacteria producing acid & gas from lactose at 37°C in 48 hours	Organisms producing acid & gas from lactose in 48 h at 37°C	Same as for Norway except incubation temperature of 35°C	See Table 2	Aerobic and facultative anaerobic, gram-negative non-sporeforming rod-shaped bacteria producing gas from lactose at 35°C in 48 hours
2. Samples						
a. Volume/tube, ml	(100 ml or 5 x 10, 1 x 50 ml ( (	(5 x 10 ml 5 x 1 ml 5 x 0.1 ml ( (	(1 x 50 ml 5 x 10 ml 5 x 1 ml ( (	(5 x 100 ml 5 x 10 ml 5 x 1 ml ( (	(1 x 50 ml 5 x 10 ml 5 x 1 ml ( (	(5 x 100 ml ( or 5 x 10 ml ( (
b. Tubes/sample	(	(	(	(	(	(
c. Are diluted samples analyzed	No	Not routinely	Not routinely	Not routinely	Yes, if highly contaminated	No

TABLE D-3 -- Continued

	Canada	Denmark	FRG <sup>2</sup>	France <sup>2</sup>	Greece	Israel	Italy
3. Dilution water, if used, specify formula	--	Phosphate buffered distilled water	Normal saline or tap water	Distilled water or Ringer's 1/4x	Ringer's solution 1/4x	--	--

TABLE D-3 -- Continued

	Netherlands	Norway	Spain	Sweden	UK	US
3. Dilution water, if used, specify formula	0.1% peptone	Not specified	--	Phosphate buffered distilled water	Ringer's solution 1/4x	--



TABLE D-3 -- Continued

	Canada	Denmark	FRG <sup>2</sup>	France <sup>2</sup>	Greece	Israel	Italy
<b>4. Media</b>							
a. Presumptive test	Lactose or lauryl tryptose broth	MacConkey broth	Lactose broth (double strength), Endo agar	Lactose broth	Minerals modified glutamate or MacConkey's broth	Lactose broth	Lactose broth
b. Is double strength required for 10 ml portions	Yes	Yes	Yes	Yes	Yes	Yes	Yes
c. Confirmed test	Brilliant green bile broth	MacConkey broth	Endo agar, tryptophane broth, citrate agar, sugar broths, cytochrome oxidase	Brilliant green <sub>3</sub> bile broth	MacConkey agar, lactose broth	MacConkey agar or brilliant green broth	Brilliant green bile broth
d. Completed test, if used, specify	EMB or Endo agar, lactose broth, nutrient agar	--	--	--	--	--	--
e. Sterilization - time and temperature	15 min, 121°C	15 min	20 min, 0.8 atm	20 min, 120°C	12-20 min, 115°C	15 min, 121°C	15 min, 121°C

TABLE D-3 -- Continued

	Netherlands	Norway	Spain	Sweden	UK	US
<b>4. Media</b>						
a. Presumptive test	Minerals modified glutamate (oxid)	Lactose-peptone broth with brom cresol purple	Lactose broth with brom cresol purple	Lactose broth with brom cresol purple	Improved formate lactose glutamate broth or minerals modified glutamate (oxid)	Lauryl tryptose broth
b. Is double strength required for 10 ml portions	Yes	No, triple (3x)	Yes	Yes	Yes	Yes
c. Confirmed test	Brilliant green bile broth	Brilliant green bile broth	Not required but identify coliforms isolated on EMB agar	Brilliant green bile broth or Endo agar	Brilliant green bile broth or lactose ricinoleate broth	Brilliant green bile broth
d. Completed test, if used, specify	--	Brilliant green bile broth	--	Brilliant green or Endo agar	MacConkey agar, nutrient agar	EMB agar, lauryl tryptose broth, nutrient agar
e. Sterilization - time and temperature	15 min, 121°C	15 min, 110°C	20 min	15 min, 110°C	IFLG 10 min, 115°C BGB 15 min, 115°C LRB 20 min, 115°C	15 min, 121°C

TABLE D-3 -- Continued

	Canada	Denmark	FRG <sup>2</sup>	France <sup>2</sup>	Greece	Israel	Italy
5. Incubation							
a. Presumptive test, time and temperature	48 + 3, 35 ± 0.5°	48 h 37 ± 0.1°C	20 + 4, 37 ± 0.5°	48, 30 + 1° (or 37°)	48, 37°	24/48, 35°	24/48, 37°
b. Confirmed test, time and temperature	48 + 3, 35 ± 0.5°	24 44°C	Negative at 20 + 4 h at 44 ± 1°C	48, 37°	24/48, 37°	24, 35°	24/48, 37°
6. Counting and reporting							
a. Define positive tubes							
Presumptive	Gas in any amount	Acid & gas	Acid & gas	Gas	Acid & gas	Gas in any amount	Gas in any amount
Confirmed	Gas in any amount	Acid & gas	See Item 7	Gas	Typical colony gram-negative: coliform	Red and dark pink colonies	
b. Units of reporting results <sup>1</sup>	MPN/100 ml	MPN/100 ml	Coliforms present or absent/100 ml; coliform titer	MPN/100 ml	MPN/100 ml, % tubes positive	MPN/100 ml	MPN/100 ml

TABLE D-3 -- Continued

	Netherlands	Norway	Spain	Sweden	UK	US
5. Incubation						
a. Presumptive test, time and temperature	48, 37°	24/48 + 3, 37 ± 0.5°	48 h 30 ± 1°C	48, 35 ± 0.3°	48, 37°	24/48 + 3, 35 ± 0.5°
b. Confirmed test, time and temperature	48, 37°	24/48 + 3, 37 ± 0.5°	--	48, 35 ± 0.3°	48, 37°	24/48 + 3, 35 ± 0.5°
6. Counting and reporting						
a. Define positive tubes						
Presumptive	Acid & gas	Acid & gas	Acid & gas	Acid & gas	Acid & gas	Gas in any amount
Confirmed	Gas	Gas	Pink & dark colonies with metallic sheen on EMB agar	Gas	Gas	Gas
b. Units of reporting results	MPN/ml or 100 ml, present or absent in 100 ml	MPN/100 ml	--	MPN/100 ml	MPN/100 ml	MPN/100 ml, % tubes positive

TABLE D-3 -- Continued

	Canada	Denmark	FRG <sup>2</sup>	France <sup>2</sup>	Greece	Israel	Italy
7. Completed test (coliform verification)							
a. Required frequency	As required	No	Yes, all samples	See footnote <sup>3</sup>	Yes, for chlorinated samples	No	No
b. Procedure	Streak on EMB or Endo agar, pick colonies to lactose broth and nutrient agar; gas, non-spore-forming, gram-negative = coliform		Streak on Endo agar, pick to lactose broth, tryptophane broth, citrate agar; gas, incubation at 44 + 0.5°C, & indole produced, citrate & cytochrome oxidase (-) = <u>E. coli</u>		Gas from lactose, gram-negative rods		
c. Adjustment of results per completion	Yes	--	Yes		Yes	--	

TABLE D-3 -- Continued

	Netherlands	Norway	Spain	Sweden	UK	US
7. Completed test (coliform verification)						
a. Required frequency	No	Yes, for new sources or as necessary	As required	Yes, if results difficult to interpret	Yes, for treated water	Yes on 10% of positive samples or 1x/3 months
b. Procedure		Gas from lactose at 44°C and indole positive	Identify coliforms isolated on EMB agar (by indole, urease, & citrate utilization tests); gram (-) rods	Gram and spore stain of colonies from Endo agar, gas from lactose	Typical colonies on MacConkey agar, IMViC and oxidase negative	Same as Canada
c. Adjustment of results per completion		Yes	--	Yes	Yes	Yes

TABLE D-3 -- Continued

	Canada	Denmark	FRG <sup>2</sup>	France <sup>2</sup>	Greece	Israel	Italy
8. Water quality standard	90% of samples in consecutive 30 days negative; no coliforms in 2 consecutive samples; no sample with MPN > 10/100 ml	Coliforms should be absent in 100 ml	Coliforms should be absent in 100 ml; no <u>E. coli</u> /100 ml	See Table 2, #9	See Table 2, #9	Good: < 2/100 ml; repeat sampling: 3-10/100 ml (if positive, check for fecal coliforms); > 10/100 ml, repeat sampling immediately	Coliforms and thermo-tolerant coliforms should be absent in 100 ml

TABLE D-3 -- Continued

	Netherlands		Norway	Spain	Sweden	UK	US
8. Water quality standard	See Table 2, #9	See Table 2, #9	See Table 2	Clean water; suitable < 1/100 ml; unsuitable > 10/100 ml	See Table 2, #9	10 ml sample: < 10% tubes positive/month 100 ml samples: < 60% tubes positive/month	

<sup>1</sup>MPN = Most probable number derived from tables in Standard Methods (American Public Health Assoc., 1976). 14th edition, pages 923-925.

<sup>2</sup>Method of choice = Membrane filter technique.

<sup>3</sup>Unofficial confirmation uses brilliant green bile broth. Official procedure requires confirmation of E. coli (gas in bile broth and indole production, both at 44 + 0.5° or isolation and identification of all coliforms (by streaking on EMB and incubating at 30° for 24 or 48 hours followed by IMViC tests).



1-ml portions (Sweden). If diluted samples are required, the diluents mentioned above are used.

For the presumptive test, lactose or lauryl tryptose broth are most commonly used, although several countries use chemically defined media (minerals modified glutamate broth -- Greece and Netherlands; improved formate lactose glutamate broth -- U.K.). All countries except Norway (which uses triple-strength) use double-strength presumptive medium for sample portions of 10 ml or more. For the confirmed test, brilliant green bile broth is most common except where Endo agar (FRG), MacConkey agar (Greece and Israel), or lactose ricinoleate broth (U.K.) are used. EMB or Endo agar, lactose or lauryl tryptose broth, and nutrient agar are used for the completed test. Media are sterilized by autoclaving at temperatures as high as 121°C for 15 min (Canada, Israel, Italy, Netherlands, and U.S.) and 120°C for 20 min (France and Spain) and at temperatures as low as 110°C for 15 min (Norway and Sweden).

With the presumptive test, samples are usually incubated for up to 48 h at 35 or 37°C; in the FRG, only a 24 h incubation at 37°C is required; in France and Spain incubation may be at 30°C. Likewise for the confirmed test, incubation is typically for 48 h at 35 or 37°C except for Israel (24 h at 35°C).

A presumptive-positive tube is defined as one in which gas has been produced; if the medium contains a pH indicator, gas and acid production both are required for a positive result (FRG, Greece, Netherlands, Norway, Sweden, and U.K.). Gas production is the characteristic of a positive confirmed test in all countries using a liquid confirmation medium. Results are reported either as coliforms present or absent, percentage of tubes positive, or most often, as the most probable number (MPN) per 100 ml.

The completed test is used for coliform verification and is comparable to verification in the membrane filter procedure. It is not typically required, at least not for all positive samples. As with membrane filter verification, it is sometimes defined in terms of E. coli presence (FRG, France, Norway, and U.K.) by such tests as indole production at 44°C, gas production from lactose at 44°C, or the IMViC series.

The water quality standards are comparable to those described above under the membrane filter technique [See also Section C.1.b].

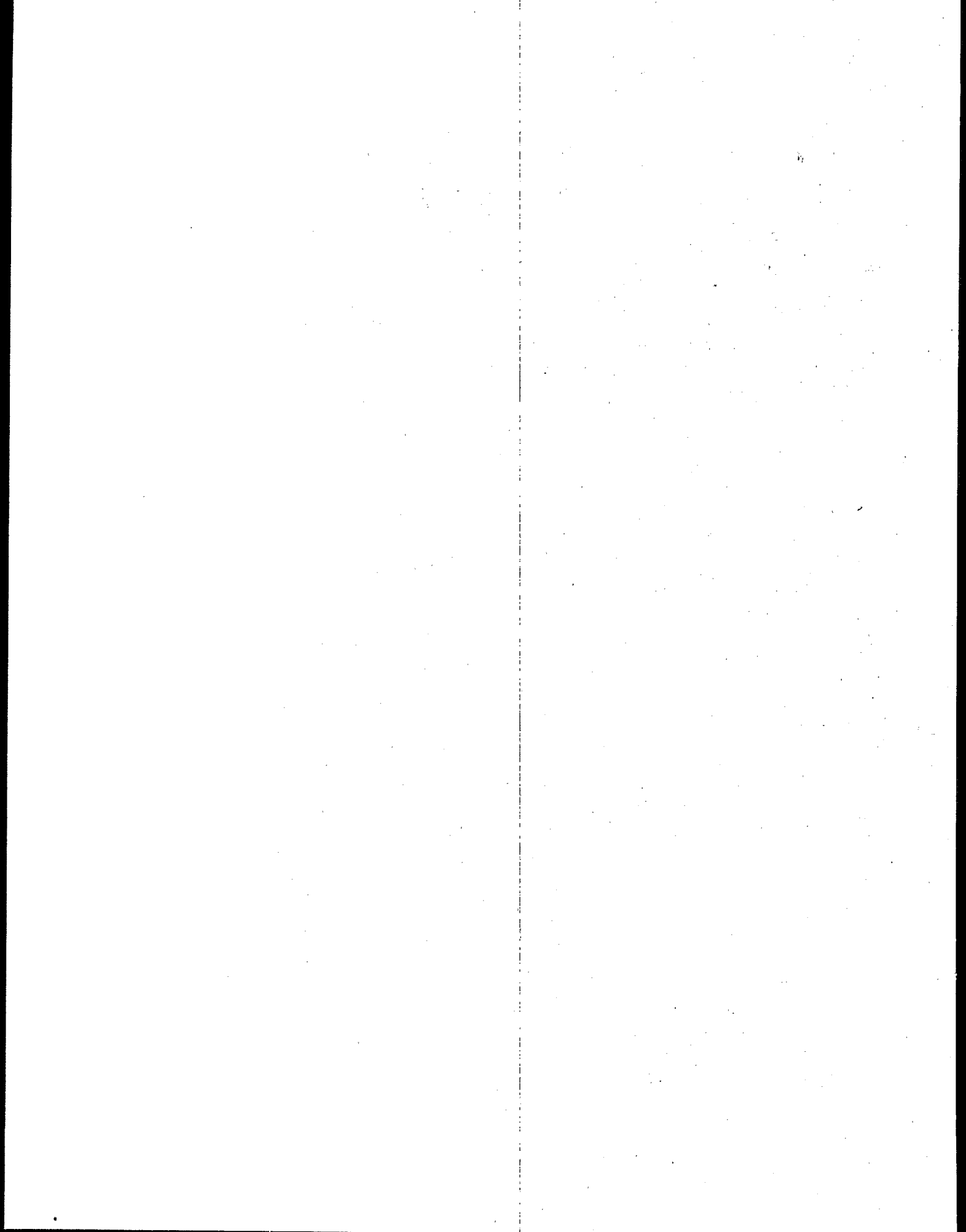

#### 4. Thermo-Tolerant (Fecal) Coliform Testing, Membrane Filter Technique

Table D-4 summarizes the data obtained for the definition of thermo-tolerant (fecal) coliform bacteria and the analytical details used for the membrane filter technique. The term "thermo-tolerant" is defined as that portion of the coliform group capable of producing gas from lactose within 24 h at a temperature around 44.5°C. Several countries use the term "fecal" coliforms to convey the same information. Others, the U.K. and the FRG for example, do not base analyses for sanitary significance on the demonstration of fecal origin by the ability of coliform bacteria to ferment lactose at an elevated temperature, but rather, test specifically for E. coli.

Where the membrane filter method is used, analytical details are identical to those given in the section on total coliform testing except that the medium is M-FC broth (Teepol agar for Denmark) and incubation is at 44.0 or 44.5°C for 24 h; or, in the case of the Netherlands, incubation is 6 h at 25°C, then 12 h at 44°C; and for Denmark and the U.K., incubation is 4 h at 30°C, then 14 to 18 h at 44°C. Thermo-tolerant coliform colonies will appear blue (or yellow on Teepol agar).

The total coliform test appears to serve as a primary criterion in determining the microbiological quality of finished drinking water. However, tests for thermo-tolerant coliforms, or for E. coli, are specified in various countries for evaluation of raw water, of untreated water in distribution, and even for finished water [See Section C.1.c].

#### 5. Thermo-Tolerant (Fecal) Coliform Testing, Multiple Tube Technique

Table D-5 parallels Table D-4. The generalizations made above are equally applicable here. The definitions of thermo-tolerant coliform bacteria are comparable to those given in Table D-4, although there are some added analytical steps that are more specific for E. coli than for thermo-tolerant coliforms as a whole (gas production at 44°C and negative oxidase and urease reactions).

Except for Italy and Sweden, which make direct inoculations, those countries using the tube technique use it as

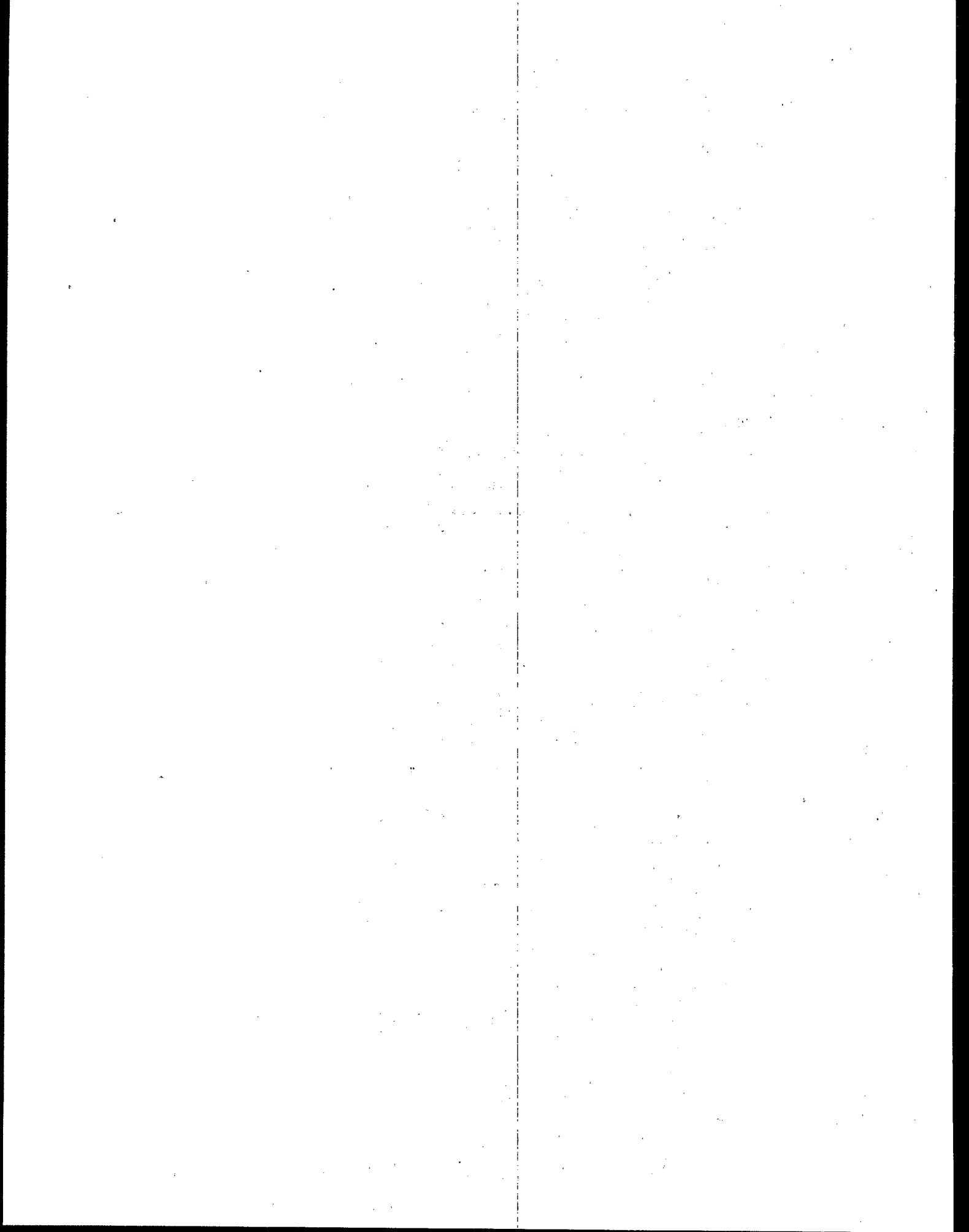

TABLE D-4

## THERMO-TOLERANT (FECAL) COLIFORM TESTING, MEMBRANE FILTER TECHNIQUE, DRINKING WATER ANALYSIS

	Canada	Denmark	FRG	France	Greece	Israel	Italy
1. Thermo-tolerant coliform, define	That portion of coliform group producing gas from lactose at 44, 5°C in 24 hours	Facultative anaerobic, gram (-) non-sporogenic rods producing indole & acid & gas from lactose in 24 h at 44°C	See footnote <sup>1</sup> See Table 2	See footnote <sup>2</sup> See Table 2	Not applicable	Not applicable	That portion of coliform group producing gas from lactose in brilliant green bile broth in 24 hours at 44°C
2. Samples	See Table 2	See Table 2					100
a. Volume filtered/ filter, ml							Not required
b. Number of replicates/ sample							No
c. Are diluted samples analyzed							--
3. Dilution water, if used							

TABLE D-4 -- Continued

	Netherlands	Norway	Spain	Sweden	UK	US
1. Thermo-tolerant coliform, define	Facultative anaerobic, gram-negative non-sporogenic bacteria growing at 37° and 44°C in lactose medium and producing gas and acid in 48 hours	That portion of coliform group growing at 44 ± 0.2°C	See footnote <sup>3</sup>	Not applicable	See footnote <sup>3</sup> See Table 2	Not required
2. Samples	See Table 2	See Table 2				
a. Volume filtered/ filter, ml						
b. Number of replicates/ sample						
c. Are diluted samples analyzed						
3. Dilution water, if used						

TABLE D-4 -- Continued

	Canada	Denmark	FRG	France	Greece	Israel	Italy
4. Media							
a. Medium	M-FC broth						M-FC broth
b. Sterilization - time and temperature	Heat to boiling, cool promptly						Heat to boiling
5. Incubation - time and temperature	24, 44.5 ± 0.2°C		4 h, 30°C then 14-18 h, 44°C				24 + 2, 44.5°C
6. Counting and reporting							
a. Appearance of fecal coliform colony	Blue						Blue
b. Visual aids used	See Table 2						No
c. Units of reporting results	No/100 ml						No/100 ml

TABLE D-4 -- Continued

	Netherlands	Norway	Spain	Sweden	UK	US
4. Media		Same as in Table 2				
a. Medium						
b. Sterilization - time and temperature						
5. Incubation - time and temperature	6 hr, 25° then 12 hr, 44°	24 + 3, 44 + 0.2°			4 h at 30°C then 14 h at 44°C	
6. Counting and reporting						
a. Appearance of fecal coliform colony		Dark red				
b. Visual aids used		Lens and lamp				
c. Units of reporting results		No/100 ml				



TABLE D-4 -- Continued

	Canada	Denmark	FRG	France	Greece	Israel	Italy
7. Thermo-tolerant coliform verification							
a. If required, frequency	--	No thermo-tolerant coliforms/100 ml					--
b. Procedure							

TABLE D-4 -- Continued

	Netherlands	Norway	Spain	Sweden	UK	US
7. Thermo-tolerant coliform verification						
a. If required, frequency	Yes, if yellow colonies present	Not routinely			Yes, for treated water	
b. Procedure	See Table 2	By comparison with multiple tube method			Transfer to 1% lactose peptone and peptone water; incubate 24 hours at 44°; gas and indole production = <u>E. coli</u>	



TABLE D-4 -- Continued

	Netherlands	Norway	Spain	Sweden	UK	US
8. Water quality standard		No thermo-stable coliforms/100 ml			<p>Treated water: no <u>E. coli</u>/100 ml</p> <p>In practice the standard is not always obtainable in the distribution system and the following standards apply:            In a year, 95% of samples should not contain <u>E. coli</u>; no sample should contain &gt; 2 <u>E. coli</u>/100 ml; no sample should contain 1 or 2 <u>E. coli</u>/100 ml if coliforms &gt; 3/100 ml</p>	

TABLE D-4 -- Continued

Footnotes:

- <sup>1</sup>E. coli identified by negative cytochrome oxidase reaction, lactose fermentation at 37°C in 20 + 4 h; indole formation, lactose fermentation at 44 ± 0.5°C in 24 hours; inability to utilize citrate. Thermo-tolerant coliform analysis not legally required.
- <sup>2</sup>Term thermo-tolerant to be used (ISO definition). E. coli identified by gas production in brilliant green bile broth at 44 ± 0.5° in 48 hours and indole formation at 44 ± 0.5°C or by picking colonies from EMB agar and making IMViC tests or by MF technique (Table 2) incubated at 44-45°C.
- <sup>3</sup>Thermo-tolerant coliform test not used but E. coli is identified. E. coli is defined as a coliform fermenting lactose with production of acid and gas at 44°C in 24 hours and giving IMViC reactions ++--.

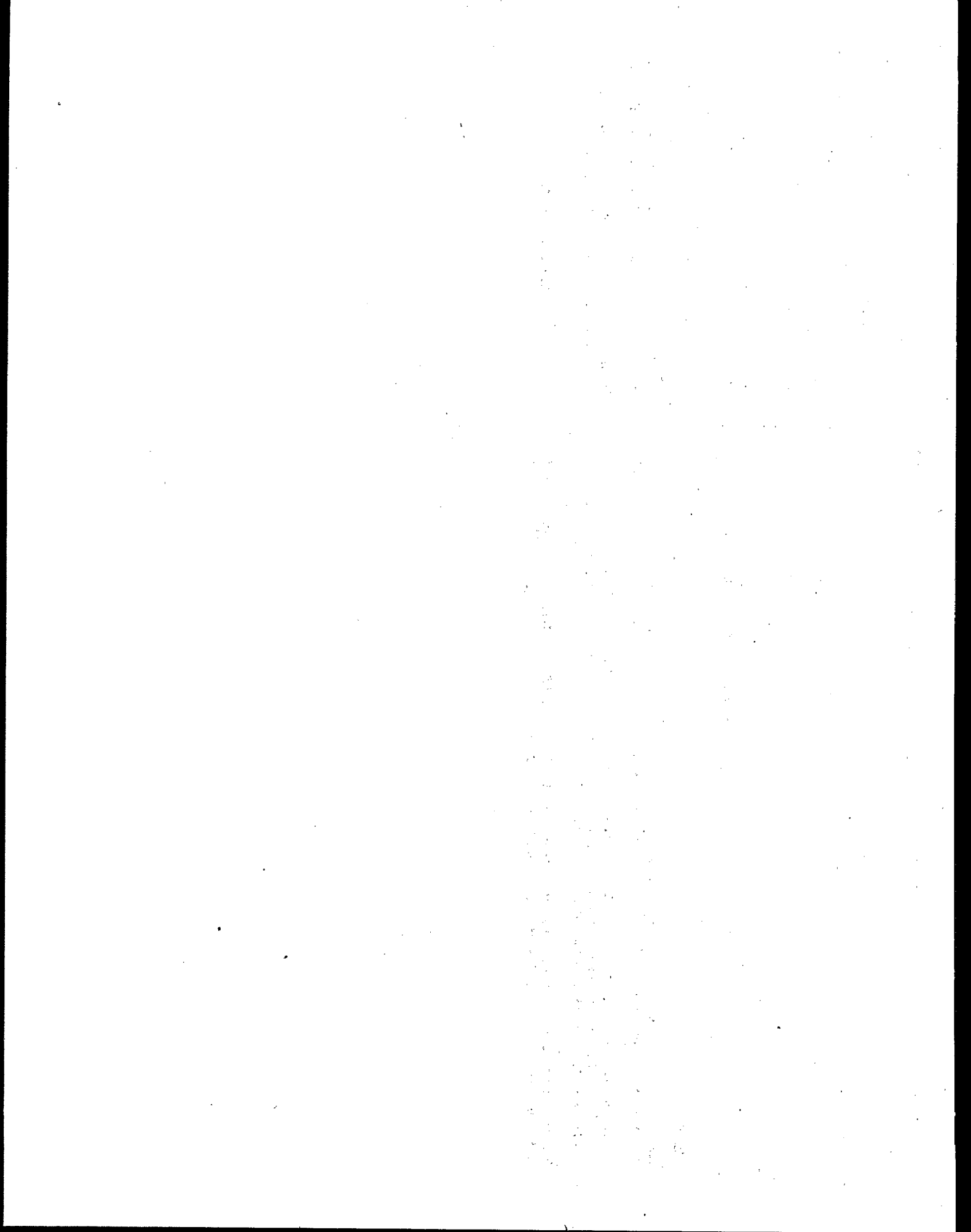

TABLE D-5

## THERMO-TOLERANT COLIFORM TESTING, MULTIPLE TUBE TECHNIQUE, DRINKING WATER ANALYSIS

	Canada	Denmark	FRG	France	Greece <sup>1</sup>	Israel	Italy
1. Thermo-tolerant coliform bacteria, definition	See Table 4	See Tables 3 & 4	Not applicable	See Tables 3 & 4	Gram-negative rods producing gas from lactose and indole at 44°C, oxidase and urease negative	That portion of coliform group producing gas in EC medium at 44.5°C in 24 hours	That portion of coliform group producing gas from lactose in brilliant green bile broth in 24 hours at 44°C
2. Samples					See Table 3		
a. Direct inoculation, ml and number of tubes	--			--		--	(5 x 10 ml (5 x 1 ml (5 x 0.1 ml ( (
b. Transfer from positive presumptive total coliform tubes	Yes, from all			Yes, from all	Yes	Yes	(
3. Dilution water, if used, specify formula	--	--		--	--	--	--

TABLE D-5 -- Continued

	Netherlands	Norway	Spain	Sweden <sup>2</sup>	UK	US
1. Thermo-tolerant coliform bacteria, definition	See Table 4	See Tables 3 & 4	See Tables 3 & 4		See Tables 3 & 4	Not required
2. Samples						
a. Direct inoculation, ml and number of tubes	--	(5 x 10 ml 5 x 1 ml 5 x 0.1 ml)		5 x 10 ml, 5 x 1 ml, 5 x 0.1 ml		
b. Transfer from positive presumptive total coliform tubes	Yes	Yes				
3. Dilution water, if used, specify formula	--	Not specified		Phosphate buffered distilled water		



TABLE D-5 -- Continued

	Canada	Denmark	FRG	France	Greece <sup>1</sup>	Israel	Italy
4. Media							
a. Medium	EC medium	MacConkey broth		Peptone water, brilliant green bile broth	Peptone water, brilliant green bile broth	EC medium	Lactose broth (presumptive) brilliant green lactose bile broth
b. Sterilization - time and temperature	15 min, 121°C	15 min, 110°C		20 min, 120°C	(a) 15 min, 110°C (b) 15 min, 121°C	15 min, 121°C	15 min, 121°C
5. Incubation - time and temperature	24 + 2, 44.5 + 0.2°	24 h, 44°C		24/48, 44 + 0.5°	24/48, 44°	24 + 2, 44.5 + 0.2°	24, 44.5°

TABLE D-5 -- Continued

	Netherlands	Norway	Spain	Sweden <sup>2</sup>	UK	US
4. Media						
a. Medium	2% brilliant green bile broth	Lactose broth with brom cresol purple		Lactose broth with brom cresol purple		
b. Sterilization - time and temperature	15 min, 121°C	15 min, 110°C		15 min, 110°C		
5. Incubation - time and temperature	48, 44°	24/48 + 3 h 37 ± 0.5°C <hr/> 24/48 + 3 h 44 ± 0.2°C		48, 44°		24, 44°

TABLE D-5 -- Continued

	Canada	Denmark	FRG	France	Greece <sup>1</sup>	Israel	Italy
6. Counting and reporting							
a. Define positive tubes	Gas	Acid & gas		Indole positive, gas	Indol positive, gas	Gas	Gas
b. Units of reporting results	MPN/100 ml	MPN/100 ml		MPN/100 ml	MPN/100 ml	MPN/100 ml	Number/100 ml
7. Water quality standard	See Table 4	See Table 4		See Table 2	Unchlorinated: none in successive samples; chlorinated; no sample > 2/100, and no sample > 1-2/100 if coliform MPN > 3/100 ml	No thermo-tolerant coliforms should be present	No thermo-tolerant coliforms/100 ml

TABLE D-5 -- Continued

	Netherlands	Norway	Spain	Sweden <sup>2</sup>	UK	US
6. Counting and reporting						
a. Define positive tubes	Gas	Gas & acid presumptive test		Acid and gas		
		Gas & indole completed test				
b. Units of reporting results	MPN/100 ml or present or absent	MPN/100 ml		MPN/100 ml		
7. Water quality standard	No thermo-tolerant coliforms should be present	No thermo-stable coliforms/100 ml		For well water: good quality = < 2/100 ml; doubtful = 2-9/100 ml; unsuitable = > 10/100 ml		

<sup>1</sup>Not legally specified but recommended by the Greek Microbiological Society.

<sup>2</sup>Not required for drinking water but used for well water and water for individual consumption.

a confirmatory test following the standardized total coliform presumptive test. Brilliant green bile broth or EC medium are usually used with incubation for 24 h at 44.5°C (Canada, Israel, Italy) or 44°C (U.K.); or an incubation of up to 48 h at 44°C (France, Greece, Netherlands, and Sweden). Gas from lactose and indole production (France, Greece, and the U.K.) is the typical positive reaction [See also Section C.1.c]. In Sweden, samples are incubated in lactose broth at 44°C and a confirmatory step normally is not done.

## 6. Colony Count

Table D-6 summarizes the data obtained on the definition of the colony count and the analytical details used. The term colony count is not uniformly used. Other terms include standard plate count, microorganism or total microbial count; aerobic or mesophilic viable bacteria, and others. Irrespective of the term employed, what is understood is the number of bacterial colonies produced per ml of water under defined conditions of medium and time, temperature of incubation, and magnification for counting. There is considerable diversity of these defined conditions as will be seen below.

Where the procedure is formally used, it is always on the basis of a pour plate technique using, at most, a 1-ml sample, typically with duplicate plates made per sample volume. As already indicated, there is no uniformity in selecting dilution water.

The media generally used are based on extracts of beef or yeast and various peptone breakdown products, solidified by agar. This variety of natural organic substances leads to nonuniformity from medium manufacturer to manufacturer and even from lot to lot when prepared by the same manufacturer. When medium diversity (planned or unplanned) is coupled with different incubation times and temperatures -- varying from 48 to 72 h at 20°C (FRG, France, Norway, and U.K.) to 48 h at 22°C (Sweden), to 48 h at 32°C (Israel), to 24 to 48 h at 35 or 37°C (Canada, France, Greece, Italy, Netherlands, and U.K.) -- it becomes clear that results among different countries cannot be directly comparable. On the other hand, it is likely that any of these national methods would identify gross differences in water quality. This suggests that, unless there is a considerable collection of data within a country, the colony count is difficult to use as part of the water quality standard. That only Canada, the FRG, Norway, and Sweden incorporate such a count into formal standards supports this point of view [See also Section C.1.a].

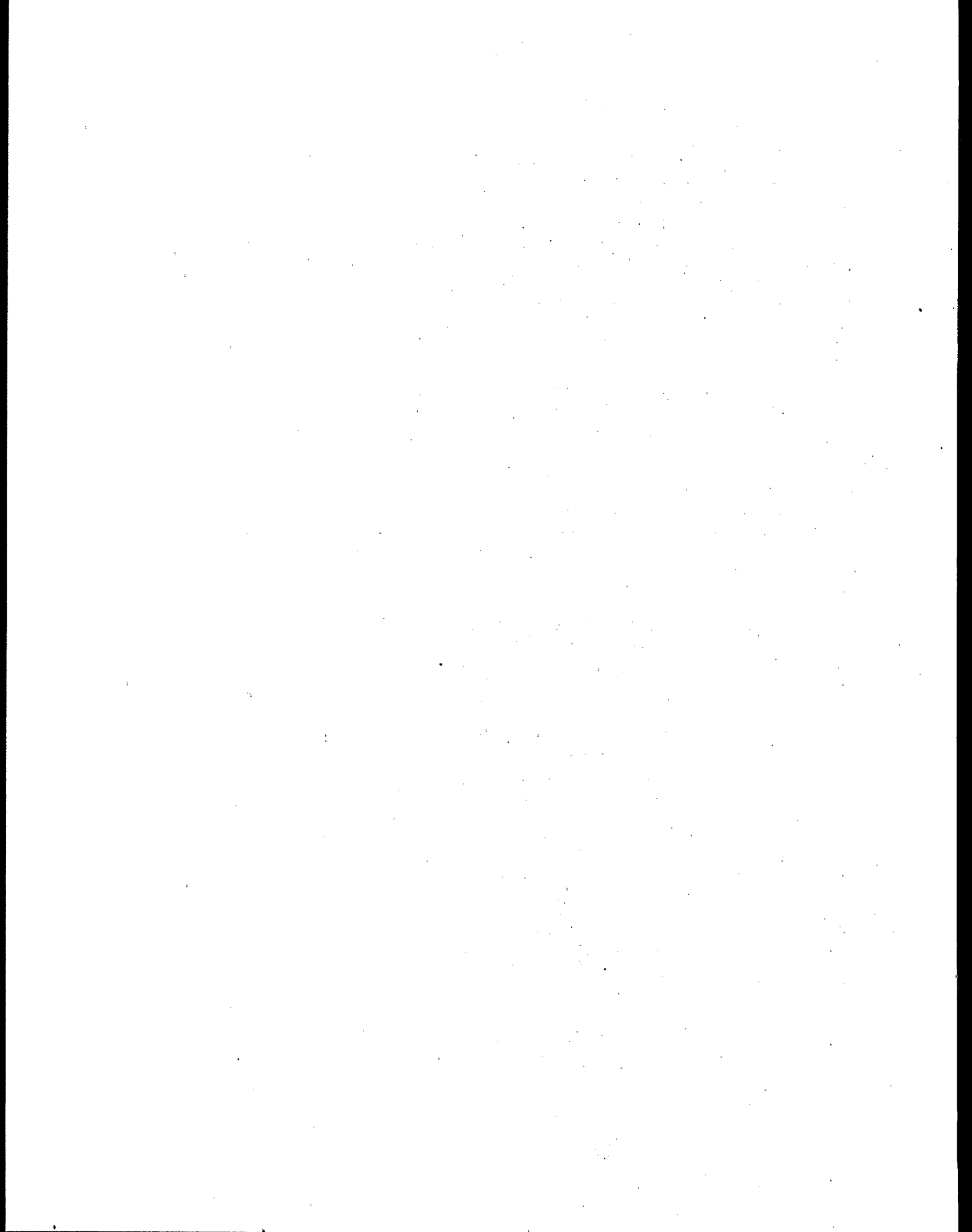

TABLE D-6

## COLONY COUNT, DRINKING WATER ANALYSIS

	Canada	Denmark	FRG	France	Greece	Israel	Italy
1. Colony count	See footnote <sup>1</sup>						
a. Define	Not legally defined, only by the analytical method	Number of colonies/ml developing on defined media at 21°C & 37°C	Number of colonies/ml developing at fixed temperature and time on defined medium	Number of colonies/ml developing at either 37° in 24 hours or 20-22°C in 72 hours on defined medium	Number of colonies/ml developing on nutrient agar at 37°C in 24 hrs	Number of colonies/ml developing on defined medium at 32°C in 72 hours	Number of colonies/ml developing on trypticase glucose extract agar
b. Procedure	Pour plate	Pour plate	Pour plate	Pour plate	Pour plate	Pour plate	Pour plate
2. Samples							
a. Volume/plate, ml	As required	1 & 0.1	1	1	1, 0.1 or 1 ml of dilutions	1	1
b. Number of replicates/sample	2/dilution	2	2	2/dilution	2	2	2
c. Are diluted samples analyzed	As required	Yes	As required	As required	As required	As required	Not required
3. Dilution water, if used	Phosphate buffered distilled water	Phosphate buffered distilled water (See Table 2)	Sterile tap water	Distilled water or Ringer's solution 1/4x	Ringer's solution 1/4x	Phosphate buffered distilled water	--

TABLE D-6 --- Continued

	Netherlands	Norway	Spain	Sweden	UK	US
1. Colony count						
a. Define	Number of colonies/ml developing on an agar medium under defined conditions	Colony forming units under defined conditions	Number of colonies/ml developing on an agar medium under defined conditions	Number of colonies visible under 1.5x magnification after 48 hours at 22°C on defined medium	Number of organisms growing aerobically and forming colonies under defined conditions	Not required
b. Procedure	Pour plate	Pour plate	Pour plate	Pour plate	Pour plate	
2. Samples						
a. Volume/plate, ml	1	1	1	1	1	
b. Number of replicates/sample	2	2	--	2	1-2/dilution	
c. Are diluted samples analyzed	As required	As required	--	As required	As required	
3. Dilution water, if used	0.1% peptone water	0.9% NaCl	Phosphate buffered distilled water or Ringer's solution 1/3x	Phosphate buffered distilled water	Ringer's solution 1/4x	



TABLE D-6 -- Continued

	Canada	Denmark	FRG	France	Greece	Israel	Italy
4. Media							
a. Medium	Tryptone glucose extract agar or tryptone glucose yeast agar	21°C count - Kings agar B 37°C count - Plate count agar	Meat extract - peptone agar	Yeast extract agar	Nutrient agar	Tryptone glucose yeast agar	Trypticase glucose extract agar
b. Sterilization - time and temperature	15 min, 121°C	15 min, 121°C	20 min, 120°C	20 min, 118°C	15 min, 121°C	15 min, 121°C	15 min, 121°C
5. Incubation - time and temperature	48 $\pm$ 3, 35 $\pm$ 0.5°	48 h, 37°C 72 h, 21°C	44 $\pm$ 4, 20 $\pm$ 2°	24 $\pm$ 1, 37 $\pm$ 1° 72 $\pm$ 4, 20 $\pm$ 22°	24, 37°	48, 32°	24/48, 37°
6. Counting and reporting							
a. Visual aids used	Quebec colony counter	None	Hand lens (8x)	Hand lens (2-4x)	Hand lens	Quebec colony counter or hand lens (9x)	None
b. Units of reporting results	Standard plate count/ml	No/ml (37°C) & no/ml total & fluorescent colonies (21°C)	No/ml	No/ml (37°) and no/ml (20°)	No/ml	No/ml	No/ml

TABLE D-6 -- Continued

	Netherlands	Norway	Spain	Sweden	UK	US
4. Media						
a. Medium	Tryptone glucose yeast agar	Meat peptone agar without NaCl	Nutrient agar	Meat peptone agar	Yeast extract agar	
b. Sterilization - time and temperature	15 min, 121°C	15 min, 121°C	20 min, 120°C	20 min, 120°C	20 min, 115°C	
5. Incubation - time and temperature	48, 37° 72, 22°	72 ± 3, 20 ± 2°	24 h, 37°C	48, 22°	24, 37° 72, 20-22°	
6. Counting and reporting						
a. Visual aids used	Automatic colony counter	Hand lens	None	Hand lens	Hand lens	
b. Units of reporting results	No/ml	No/ml (average of two replicates)	No/ml	No/ml	No/ml	

TABLE D-6 -- Continued

	Canada	Denmark	FRG	France	Greece	Israel	Italy
7. Water quality standard	< 500/ml based on geometric mean of > 10 month- ly samples for conven- tional treatment	Recommendations: 37°C < 10/ml, 21°C < 100/ml & < 5 fluores- cent colo- nies/ml	Recommendations: Non- disinfected water < 100/ ml; disin- fected water < 20/ml	Not specified	Not specified	Not specified	Not specified

TABLE D-6 -- Continued

	Netherlands	Norway	Spain	Sweden	UK	US
7. Water quality standard	Not specified	Undisinfected surface water: good < 100 ml, doubtful 100-500/ml; disinfected surface water: good < 10/ml, doubtful 10-100/ml	Clean water: suitable -- < 100/ml; less suitable > 100/ml	Clean water: suitable -- < 100/ml; less suitable > 100/ml	Not specified	

<sup>1</sup>Uses procedure given in Standard Methods for the Examination of Water and Wastewater, 14th edition, pages 908-913.

## 7. Miscellaneous

The questionnaire on laboratory practices and bacteriological standards also included a seventh set of questions, in response to which came a tremendous diversity of replies that could not be presented as tables.

The first of these questions asked about the kinds of laboratories (national, provincial, municipal, university, water utility, and nongovernmental or commercial) and their numbers in each country. Because of different national administrative arrangements, it is impossible to generalize about the kinds of laboratories analyzing water. The number of laboratories involved relates both to the role played by the central government in water quality control and, more importantly, to the size of the country. In Israel and Greece, for example, there are fewer than ten laboratories; whereas in the U.S. there are thousands of water laboratories, many of them at water utilities.

Other questions dealt with control of water laboratories and the use of standards of laboratory quality. In most countries, there is no formal system of technical supervision or direction for water laboratories, nor are there formal standards by which the acceptability or general quality of laboratory services are judged. It is assumed, however, that internal and interlaboratory quality control are achieved through good laboratory practices. In Sweden, laboratories are controlled by the National Board of Health and Welfare and each analyst is required to have a personal authorization although, in practice, authorization is required only of the supervisor. Comparable authorization for the laboratories is under consideration. In the U.S., each laboratory must be approved by the state in which it is located.

Responses to questions concerned with interpreting laboratory results and acting on laboratory findings were varied: interpretation of results and initiation of corrective action are carried out by the water analyst, a water engineer, or a health authority. No consistent pattern was evident.

## 8. Summary and Conclusions

Bacteriological assessment of drinking water quality is typically based on the coliform group of bacteria. Less

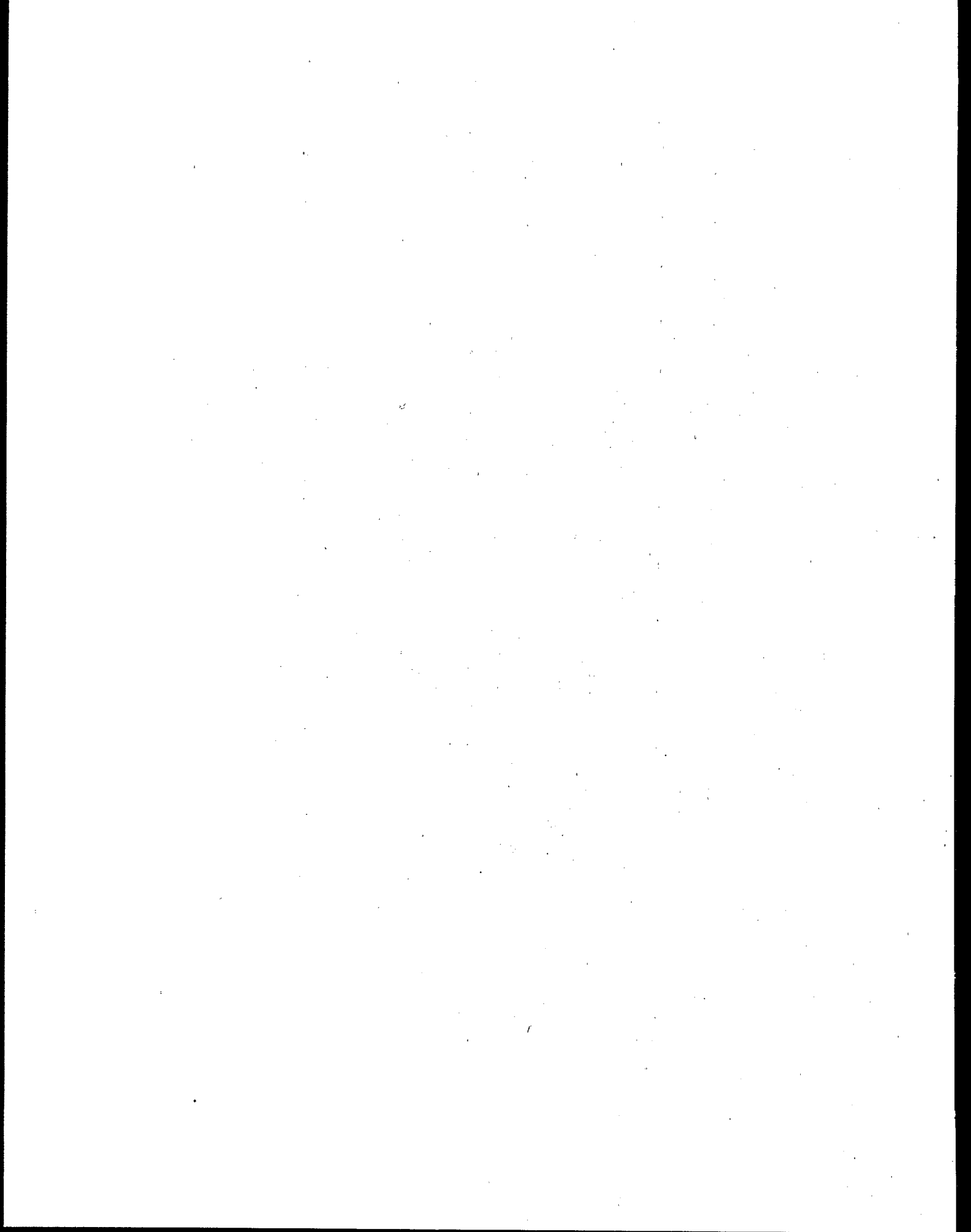

frequently, standards are based on thermo-tolerant coliform bacteria or even E. coli. Still less often, a count of aerobic heterotrophic organisms is required.

The analysis for coliform or thermo-tolerant coliform bacteria may be conducted either by the multiple tube technique, with results reported as a most probable number (MPN) per 100 ml, or by the membrane filter procedure, which yields a colony count. The least methodological diversity exists for the total coliform test even though there is no universally accepted medium or procedure. It may be concluded, however, that the specified procedures, when correctly followed, will provide closely comparable results.

Tests for thermo-tolerant coliforms are more varied, most notably in the time and temperature of incubation. The significance of these differences probably is slight.

The least uniform test is that made for the colony count. Here, differences in media and incubation procedures may yield markedly different results and comparisons across national boundaries may be impossible, although the extreme case of a very high count would be identified irrespective of the procedure used.

Despite the existence of formal standards of water quality, there are seldom formal standards of laboratory quality; that is, formal laboratory quality control programs, such as in the U.S., seldom exist. It may be concluded that this subject is most in need of attention.

## 9. Recommendations

1. Greater efforts should be made at the national and international level to obtain maximum comparability of data by the use of uniform analytical methods. The procedures of the European Economic Community appear most suitable for universal adoption.
2. The absence of formal laboratory quality assurance programs should be remedied. Procedures to establish quality assurance should be developed by national laboratories and enforced at all water laboratories. Likewise, the responsible national body should insure that, without exception, all laboratories within a country are using the adopted methods.

3. An adequate water testing program, using uniform methodologies that are under close quality assurance, cannot guarantee distribution of safe water to all consumers. Laboratory analyses merely assess the quality of water being distributed. It is essential, therefore, to have an integrated water program wherein the water authority takes action to correct deficiencies exposed by laboratory testing. The procedures should be formalized in such a way that laboratory information can be transmitted to the appropriate authority and corrective action instituted.



## E. MICROBIOLOGY OF WATER TREATMENT AND DISINFECTION

The ever increasing need for potable water has led to reliance on low quality surface water sources which necessitate intensified and improved treatment practices. Waterborne disease outbreaks resulting from insufficient treatment of microbiologically contaminated water have been well documented. Therefore, in order to prevent the transmission of diseases through water, it is of the utmost importance that treatment practices be properly chosen and carefully applied from the raw source water to the final product.

This section will evaluate several standard processes used in the treatment of drinking water [See Table E. Intro-1] in terms of their effects upon the microbiology of the water. Emphasis will be placed on enteric bacteria, in their role as indicators, and on viruses. Estimates will be made, on the basis of recent pilot studies and experiments, of the overall safety to consumers achieved through the application of these respective treatment procedures. Not included here are microbiologic processes for nitrification of water from surface sources [See the report of Project Area II: Advanced Treatment Technology] and for denitrification of groundwater.

### 1. Storage Reservoirs

The storage of raw water in large, open reservoirs can provide both quantity and improved quality of the finished water. Storage reservoirs serve as an important supply under drought conditions and also as a safeguard against polluting substances which may be present in a river. If toxic materials are spilled or discharged into the river, the intakes can be closed until the harmful substances have passed downstream. Provided that the storage reservoir is of sufficient volume, it will serve as a buffer against any sudden deterioration of the influent quality. This buffering action is particularly important where contamination may be intermittent.

TABLE E.INTRO-1

SCHEME OF TREATMENT  
FOR THE PREPARATION OF DRINKING WATER

---

---

Treatment 1	Reservoir storage
2	Dune infiltration
3	Coagulation
4	Sand filtration
5	Activated carbon
6	Disinfection

---

a. Physical and Biological Factors. Surface waters may be purified by a treatment process consisting of several stages, the first of which is storage. Storage immensely improves the physical, chemical, and microbiological quality of the source water which is particularly important when this is a river polluted with sewage effluent. Loss of turbidity is perhaps the most striking improvement in that particulate matter, along with adhering microorganisms, will sediment out.

Sunlight has a lethal effect on bacteria and other microorganisms, and high coliform mortalities have been shown to occur in seawater during daylight hours (Gameson and Saxon, 1967). Radiation of the shortest wavelength (ultra-violet and the blue end of the visible spectrum) is bactericidal and its lethal potency is approximately proportional to its intensity. Except when algal and cyanobacterial blooms interfere, sunlight penetration is enhanced by the reduced turbidity obtained from sedimentation.

It is well known that higher temperatures increase microbial metabolism, leading to accelerated die-off rates of indicators and pathogens. A rise in water temperature will also increase predator activity. Certain protozoa are particularly active bacterial feeders, as can be seen at a sewage effluent outfall where ciliates abound and help reduce the vast numbers of bacteria. Among the somewhat larger animals, rotifers and members of the genus Daphnia are important predators of bacteria. The latter frequently graze on and remove large numbers of E. coli from reservoir water [See Section A.2]. The minute Bdellovibrio bacteriovorus can grow on gram-negative bacteria by penetrating the cell wall and multiplying within the cell. It is highly motile, can rapidly clear dense suspensions of gram-negative bacteria, and can grow equally well on live or dead cells (Guelin, et al., 1967). Bacteriophages (bacterial viruses) cause lysis of bacteria cells, but are only able to develop on actively growing bacteria. Since intestinal bacteria, such as E. coli, are not capable of multiplying in reservoir water, death from coliphage infection may be minimal [See Section C.2.a].

Although lethal to some microbes, antibiotics (produced by actinomycetes and fungi) and toxins (produced by cyanobacteria) probably play a minor role in reducing numbers of enteric bacteria whose populations are, in most cases, already greatly diminished by the lack of available nutrients, competition, and predation. The stresses exerted

by an entrenched and well adapted aquatic community render the reservoir an unfit environment for enteric bacteria.

According to Holden (1970), "it is impossible to assign the exact importance of each factor in the self-purification of water," because of the large number of agents operating simultaneously. It is obvious that different climates will have varying influences -- areas of high temperature combined with sunlight being strongly bactericidal in clear water.

b. Effect of Storage on Indicator Organisms. Thermo-tolerant coliforms (i.e., E. coli and other fecal coliforms) are the prime indicators of fecal pollution [See Section C.1.c]. E. coli is present in the intestine of man, animals, and birds and outnumbers the pathogens by millions to one in sewage. Its reduction can be traced through the various stages of water treatment, but is largely accomplished during storage. The following pertains to the effect of storage as carried out by the Metropolitan Water Division of the Thames Water Authority, U.K., and special reference will be made to these storage reservoirs.

Approximately two-thirds of London's water supply is obtained from the Thames River and one-sixth from the Lee River, with the remainder derived from underground sources. Numbers of E. coli are regularly monitored in both these rivers at the intakes to many of the storage reservoirs. Water is stored in the large reservoirs of the Thames Valley for periods of seven to ten weeks depending on demand, whereas in the Lee Valley the retention period is considerably less. The percentage reductions of E. coli during storage were computed from quarterly figures for the years 1971 to 1976 (Metropolitan Water Board, 1971-1973b; Thames Water Statistics, 1976). Though they varied by season, these losses remained considerable throughout.

During spring and summer, many 100 ml samples collected from reservoir outlets contained no E. coli, whereas only three reservoir samples taken in autumn and winter were free of E. coli. Storage reservoirs in the Thames Valley reduced E. coli by 95.7 to 99.8 percent in the spring, and by 90.7 to 99.7 percent in the summer. At these seasons, sunlight, temperature, and biological factors would be exerting their maximum influence. In the autumn, E. coli reductions during storage varied from 77.8 to 98.1 percent and in the winter, from 85.7 to 98.2 percent. It is noteworthy that the lowest

reductions for each season occurred in a reservoir which utilizes mixing jets to prevent thermal stratification. Storage reservoirs in the Lee Valley exhibited smaller seasonal fluctuations in E. coli removal, most likely because of their shorter retention times as compared to those in the Thames Valley. However, as in the previous cases, the lowest removal (84.3 percent) occurred in the autumn; winter reductions were > 91.8 percent, and spring and summer storage removed > 95.2 and 93.4 percent, respectively.

The storage-induced decline in bacterial numbers was studied in a small reservoir in the Lee Valley (Poynter and Stevens, 1975). The reservoir was filled with a mixture of water from the Thames and Lee Rivers, and then closed. The water was sampled weekly during the autumn of 1974 and showed the greatest decline in E. coli, 95.8 percent, within the first week. In the following eight weeks, low numbers of E. coli were isolated, suggesting that feces from birds and animals and/or rainfall runoff from reservoir banks were the contaminating source. When a sample of this reservoir water was inoculated in vitro with strains of E. coli (recently isolated from the Thames River and from feces), at a level of 260 E. coli per 100 ml, and stored in the dark at 15 to 16°C -- the rate of decline was logarithmic, ending with near extinction (E. coli absent from 100 ml) within 11 days.

Many coliforms present in feces can survive better than E. coli outside the body. Many are widely distributed in nature and may gain access to water from non-fecal sources. Under certain circumstances, they may multiply on decaying vegetation, wood, or other materials [See Section C.2.d]. Three weeks after copper sulfate was added to a storage reservoir to control a spring growth of diatoms, there was evidence of coliform growth in the secondary slow sand filter beds (Burman, 1961). Coliforms are usually reduced considerably, but less so than E. coli, during storage. In the previously described study of the small storage reservoir in the Lee Valley (Poynter and Stevens, 1975), coliforms decreased by 85 percent in the first week, but required two weeks to be reduced by 90 percent (the decline of E. coli was almost 96 percent by the end of the first week). During the remaining seven weeks, coliform reductions fluctuated between 92 and 99.5 percent.

The term fecal streptococci [See Section C.1.d] applies to the Streptococcus faecalis-faecium-durans group (enterococci) and the S. bovis-equinus group (i.e., they all belong to Lancefield's serological group D). The reported die-off

rates of fecal streptococci and fecal coliforms in natural waters (Geldreich and Kenner, 1969; Kjellander, 1960; McFeters, et al., 1974) can be summarized as S. bovis-equinus group > fecal coliforms > S. faecalis-faecium group. S. faecalis is abundant in human feces, whereas S. faecium is widespread in both man and animals. Thus, in a storage reservoir where the water source is a sewage polluted river, streptococci may be isolated in the absence of E. coli. However, when water samples from the Lee River were stored in clear glass bottles of 2.8 l capacity, in the dark or in the light, the observed die-off rates of fecal streptococci were similar to or greater than those of E. coli (Burman, et al., 1978). In these samples, the major source of fecal pollution was considered to be treated sewage effluents.

Clostridium perfringens [See Section C.1.e] is present in feces in much smaller numbers than either E. coli or the fecal streptococci. It differs from these organisms in that it produces spores which are resistant to adverse conditions and, therefore, better able to survive for extended periods. The presence of C. perfringens in a source water indicates fecal contamination and, in the absence of coliforms, suggests that the contamination occurred at some remote time. The die-off rate of these organisms in a storage reservoir would be slow, although sedimentation may account for apparent reductions of spores adhered to particulates.

Storage may also act to reduce considerably the number of bacteria able to form colonies on yeast extract agar at 37°C (and, to a certain extent, of those which form colonies at 22°C). The Lee Valley reservoir study (Poynter and Stevens, 1975) showed a 50 percent decline the first week, and a 72 percent decline the second week, in colony counts on plates incubated at 37°C for 24 h. However, due to the incidence of algal blooms there may be a considerable increase in colony counts at both 37°C and 22°C, which may occur during or after the algal blooms as was shown in the Dutch storage reservoir "De Grote Rug" (Kool, 1977). Peaks of bacterial numbers also coincided with peaks of algal activity in a Thames Valley reservoir, U.K. (Price and Valadon, 1970). Thus, under certain conditions, bacterial increases, rather than decreases, will take place in a reservoir.

c. Effect of Storage on Bacterial Pathogens. All drinking water supplies should be free from pathogens, such as those responsible for typhoid, paratyphoid, dysentery,

cholera, bacterial or viral gastroenteritis, and infectious hepatitis [See Section B]. For practical purposes, typhoid fever, cholera, and infectious hepatitis are regarded as exclusively human diseases, while the other diseases may be of human or animal origin. The agents of all these diseases are discharged in the excreta (feces or urine) of patients or carriers. Thus, if these diseases are prevalent within a population, the causative agents will be present in sewage; and if this sewage is discharged to a river which is used to supply a reservoir, the presence of such pathogens can be expected.

The effect of storage on Salmonella typhi (the agent of typhoid fever) was investigated some 70 years ago by Houston. His "Reports on Research Work" (Houston, 1908-1911) dealt with several experiments, the first of which involved 18 samples of river water, six each from the Thames, the Lee, and the New Rivers. Each of the 4 l samples was inoculated with a single strain or a mixture of different strains (27 in three of the experiments) of S. typhi, some of which had been recently isolated from typhoid patients. The inoculated river water samples were stored in the dark at temperatures ranging from 8 to 20°C. The numbers of S. typhi organisms added to the samples ranged from eight to 40 million per ml, and counts were made at weekly intervals. The decline was especially rapid in the first week, the reduction amounting to more than 99.9 percent in practically all experiments. However, S. typhi could still be recovered from 100 ml of water, in some experiments, during the eighth week of storage. Later, Houston carried out further experiments on much larger volumes (1.6 m<sup>3</sup>) of Thames River water. He noted that temperature greatly affected the viability of S. typhi, survival being considerably longer at low temperatures. As a result of his work, he concluded that "an adequately stored water is a safe water."

Experiments were carried out in the U.S. (Jordan, et al., 1904) in which river, lake, or canal water was inoculated with S. typhi. The inoculated water was enclosed in permeable sacs made of celloidin and parchment to allow dialysis, and these sacs were suspended in flowing river, lake, or canal water. Under these conditions, designed to simulate those in nature, the majority of S. typhi perished within three to four days. The experimental results of Thresh and coworkers (described by Holden, 1970) are in general agreement with those of Houston, especially with regard to the sudden initial decrease of S. typhi in polluted waters. Though samples contained only five organisms

per ml of river water, both S. typhi and S. paratyphi decreased considerably in the first four days and were absent from 1 l after three weeks' storage in the dark at 10 to 15°C.

While typhoid fever, which is exclusively a human disease, rarely occurs in the U.K., Salmonella-induced gastroenteritis is comparatively widespread among humans and animals [See Section B.1.a(i)]. Storage experiments were carried out by Fennell and coworkers (1974) on the survival of S. typhimurium in reservoir water. Two outlet samples of reservoir water (pH 7.3) were tested; one was naturally contaminated with 25 salmonellae per l and the other was inoculated with S. typhimurium (isolated from the reservoir during the previous week), to yield a count of 120 per l. Ten l volumes of water were stored at approximately 5°C in the dark. At the end of the first week of storage, the reduction was approximately 50 percent and after two weeks, 75 percent. By the middle of the third week, salmonellae were difficult to isolate and at the end of the third week, the count was only one per l. Storage at the low temperature of 5°C (at pH 7.3) probably accounted for the comparatively small reduction (50 percent) in the first week. When inlet water with a pH of 5.6 was inoculated with 120 S. typhimurium per l, death occurred more rapidly, reaching a 95 percent reduction by the end of the first week, and a 99 percent reduction after two weeks. After 17 days of storage, no salmonellae could be isolated. In contrast to these results with S. typhimurium, Cohen (1922) demonstrated that the death rate of S. typhi was minimal within a pH range of 5.0 and 6.4. A change in pH from 5.4 to 3.8 accelerated the death rate by almost a hundredfold, while a similar change in pH on the alkaline side increased the death rate about four to fivefold. It is clear from these examples that both pH and temperature are important to the survival of Salmonella [See Section B.1.a(i)].

Gulls feeding on domestic sewage, either at the sewage works, at effluent outfalls, or at refuse disposal sites and subsequently excreting Salmonella elsewhere, represent a widespread problem. Muller (1965) collected more than 1,000 fecal samples from gulls in Hamburg around the area of the biggest sewage works, on bridges and pontoons in the port of Hamburg, and in the streets of the city; 78, 66, and 28 percent of these samples, respectively, were positive for Salmonella. In such widely separated areas as Hamburg, Venice, and Tanganyika, approximately 30 percent of pigeon feces contained Salmonella, whereas 16 percent of duck feces



in Hamburg carried the pathogen (Muller, 1965). During a thirteen-month survey of a storage reservoir in Yorkshire, U.K. (Fennell, et al., 1974), Salmonella was isolated from 52 out of 111 water samples from the reservoir, but never from the inlet water of the catchment area. The number of roosting gulls was at a maximum in December and the bacteriological quality of the reservoir water deteriorated markedly during the winter. There was a close correlation between the number of gulls and the degree of contamination with Salmonella, E. coli, and fecal streptococci all of which are excreted in large numbers by gulls. There was no correlation between the number of gulls and presence of Clostridium perfringens, since these organisms occur only in small numbers in gull feces. The presence of large birds, in high numbers on open storage reservoirs may pose a serious problem either from direct fecal discharge and/or from rainfall runoff along contaminated banks.

There have been few reports in the literature of the isolation of Shigella from river water, sewage, and sewage effluent; and this has generally been associated with the organism's poor stability outside the human body. However, the failure to isolate Shigella from polluted water may instead be due to unsuitable selective isolation techniques. Shigella has a longer generation time than many of the competing organisms, and this complicates the use of an enrichment medium [See Section B.1.a(ii)].

Cholera has been practically non-existent within the U.K. for more than 70 years, but prior to that period epidemics occurred at intervals. Houston (1909) carried out a series of 18 experiments on the survival of Vibrio cholerae in raw river water (six each from the Thames, the Lee, and the New Rivers) similar to those he conducted with S. typhi. The initial inoculations numbered from 70,000 to 13 million per ml of water, and samples were stored in the dark at temperatures ranging from 7 to 18°C. The cholera vibrios died out very rapidly; and in all 18 experiments, there was a reduction of at least 99.9 percent within one week. None could be isolated from 100 ml of water after three weeks, and negative results were obtained after two weeks in over half the experiments. Survival was longest in samples receiving the most massive inocula. The survival of a very small fraction of organisms, which is more resistant, is not uncommon and may be correlated with the initial number of cells in the inoculum. Houston interpreted his results as indicating that cholera vibrios were "even less hardy" than

typhoid organisms and that the storage time required to protect reasonably well against typhoid fever was more than sufficient for cholera [See Section B.1.a(vii)]. Cholera is endemic in India, and cholera vibrios have been found to perish only a few hours after entering certain rivers, such as the Ganges and Jumna (Holden, 1970). This is due to factors such as high temperature and the presence of an established predator population sustained by frequent fecal inputs. Conversely, the survival of enteric organisms is now known to be more prolonged in pure than in polluted water.

d. Effect of Storage on Enteroviruses. Reservoir storage causes a marked reduction in virus levels. From December 1974 to March 1975, water samples from the river intakes to the storage reservoirs in the Thames and Lee Valleys were compared with the outlet water from these reservoirs (Slade, 1977). Virus numbers in the River Thames ranged from 12 to 49 plaque-forming units (PFU) per liter, and in the Lee River, 0.8 to 11.8 PFU per liter. Large numbers of enteroviruses are frequently isolated during the winter months; the Thames River normally has more viruses than the Lee River. The virus numbers, after storage in the Thames Valley reservoirs, varied between 0.00 and 9.73 PFU per liter. The latter result was high and no other exceeded 1.93 PFU. Numbers after storage in the Lee Valley reservoirs ranged from 0.00 to 1.00 PFU per liter.

Temperatures of the stored water in the Slade study at the time of sampling ranged from 5 to 7°C, and the results can be compared to those of Poynter (1968) who also studied virus inactivation in water from the Lee River. He found that at a temperature of 5 to 6°C, more than nine weeks of storage were required for 99.9 percent inactivation of poliovirus type 3; but at temperatures of 15 to 16°C, 95 percent inactivation occurred in seven days and 99.75 percent in less than 15 days [See also Section B.1.b]. These results, which are sufficiently similar to the results obtained for enteropathogenic bacteria, uphold the value of storage reservoirs as a highly desirable method of safeguarding water supplies when the source is a polluted river.

As a result of his research, Houston concluded that 30 days of storage, prior to filtration, should suffice to provide a safe water. However, this is not always practical and "it is now generally agreed that inflow-outflow arrangements which ensure at least ten days of retention in the

storage reservoir are practical methods of eliminating between 75 and 99 percent of the excremental organisms" (Holden, 1970). In temperate regions, the greatest reductions occur in spring and summer, and the least reductions in autumn and winter, especially during prolonged cold weather. At a water temperature of 4 to 8°C, a retention time of about 75 days was required for a 99.9 percent reduction of enteric viruses (Kool, 1979).

e. Recreational Use of Reservoirs. In some developed countries, there is now an increasing awareness of the amenities (connected) with open storage reservoirs. They may be stocked with fish, such as trout, and so attract fishermen. They may also be used for boating and by sailing clubs. Power-driven boats (apart from those involved in rescue) should be excluded to avoid any accidental spillage of oil or other toxic substances. Swimming (or any total immersion) should likewise be prohibited. Large numbers of people visiting a reservoir would dictate the need for adequate nearby toilet facilities. Provided that these and other safeguards are strictly carried out, storage reservoirs may serve as areas for recreation, as well as for storage and purification.

f. Summary. All the evidence indicates that storage reservoirs are invaluable as a primary stage in the treatment of fecally polluted river water. However, the advantages of storage may be lessened (or even lost) where the water is subsequently contaminated by waterfowl, such as gulls, or is used as a recreational facility without proper precautions.

## 2. Coagulation

This section will present and discuss data on the removal of bacteria, enteric viruses, and parasitic cysts by coagulation with aluminum and iron salts followed by sedimentation. Most studies cited here report effects of coagulation with raw surface water or secondary effluent, but others, in which raw wastewater was tested, were also included in order to provide more complete coverage.

Coagulant dosages, stated for compounds in which the water of hydration obviously was present, were reduced accordingly; otherwise, the concentrations are shown as reported. For example, in studies where aluminum sulfate had been the coagulant used, the concentration indicated

was reduced for this report by a factor of 0.486 (18 waters of hydration) to convert to  $Al_2(SO_4)_3$ . In cases where ferric sulfate or ferric chloride was used without designation of the water of hydration, the concentration reported in the study was used here. However, some studies may have neglected to include the waters of hydration in reporting concentrations of ferric compounds, in which case, the actual concentration of active compound would have been less than that reported here.

a. Removal of Bacteria. Data on the removal of bacteria by coagulation and sedimentation have been taken primarily from early studies since this subject has drawn little attention in the current literature [See Table E.2-1]. Gehm (1944) obtained reductions in colony counts of 97 percent from raw sewage to which 60 mg per l of  $FeCl_3$  had been added, although only 77 percent of B. coli (now E. coli) were removed. When 40 mg per l of  $FeCl_3$  was applied, colony counts were reduced by about 20 percent, although 50 percent of the E. coli were removed under similar conditions.

Early studies (Streeter, 1927, 1929) reported average bacterial removals obtained at full-scale water treatment plants on the Ohio River and Lake Erie [See Table E.2-1]. Reductions at the Ohio River plants averaged 83 percent for both colony counts and E. coli, but only 46 percent for colony counts and 76 percent for E. coli at the Lake Erie plants. Turbidity was reduced by about the same percentages as were bacteria. However, only three of the seven Ohio River plants employed flocculation, of which only one allowed more than 6 min of detention time (20 min). Of the four Lake Erie plants, only two used flocculation.

Later studies (Cummins and Nash, 1978) made at the Cincinnati, Ohio treatment plant showed that when 12.6 mg per l of  $Al_2(SO_4)_3$  were added to Ohio River water and then allowed to settle for 48 h in open reservoirs, 97 percent of total coliforms were removed [See also Section E.1]. When the effluent water was coagulated with 6.8 mg per l of  $Fe_2(SO_4)_3$  and allowed to settle for 4 h, only 42 percent of the initial 2,400 coliform bacteria per 100 ml were removed. The latter procedure more nearly typifies actual treatment plant operations, but the former offers evidence of the advantages to be had from longer sedimentation with its increased opportunities for bacterial die-off.

Results vary widely in the few available reports on removal of bacteria by coagulation and sedimentation. The

TABLE E.2-1

## REMOVAL OF BACTERIA BY COAGULATION WITH ALUMINUM SULFATE AND SEDIMENTATION

Water Source	Indicator System (initial conc. per ml)	Conditions of Coagulation				Removal		Type Study <sup>b</sup>	Reference and Remarks
		Coagulant Dose (mg/l or ppm)	Turbidity (TU)	Temp. (°C)	Final pH	Indicator (%)	Turbidity		
River	Colony count (2951)	10.5	168	14	NS <sup>c</sup>	83	90	F	Streeter (1927) avg. of 7 plants on Ohio River
River	<u>E. coli</u> , index (3526)	10.5	168	14	NS	83	90	F	Streeter (1927) avg. of 7 plants on Ohio River
River	Total coliform (840)	12.6	14	22	NS	97	96	F	Cummins & Nash (1978) 48 h sedimentation
River	Colony count (1675)	20	8	NS	7.6	61	40	P	Mallmann & Kahler (1948)
River	Total coliform, coliform index (5943)	20	8	NS	7.6	74	40	P	Mallmann & Kahler (1948)
River	Total coliform, coliform index (2.5 x 10 <sup>6</sup> )	20	NS	NS	7.6	81	NS	P	Mallman & Kahler (1948)
River	Total bacterial count, MPN (NS)	25	40-135	5	6.7-7.4	98.7	1-5 TU	L	Chang, <u>et al.</u> , (1958a)
River	Total bacterial count, MPN (NS)	25	140-255	15	6.7-7.4	99.3	1-5 TU	L	Chang, <u>et al.</u> , (1958a)

TABLE E.2-1 -- Continued

Water Source	Indicator System (initial conc. per ml)	Conditions of Coagulation				Removal		Type Study <sup>b</sup>	Reference and Remarks
		Coagulant Dose (mg/1 or ppm)	Turbidity (TU)	Temp. (°C)	Final pH	Indicator (%)	Turbidity		
River	Total bacterial count MPN (NS)	25	16-240	25	6.7-7.3	99.8	1-5 TU	L	Chang, <u>et al.</u> , (1958a)
River	Total coliform, MPN (NS)	25	40-135	5	6.7-7.4	98.8	1-5 TU	L	Chang, <u>et al.</u> , (1958a)
River	Total coliform, MPN (NS)	25	140-255	15	6.7-7.4	99.4	1-5 TU	L	Chang, <u>et al.</u> , (1958a)
River	Total coliform, MPN (NS)	25	16-240	25	6.7-7.3	99.8	1-5 TU	L	Chang, <u>et al.</u> , (1958a)
River	Colony count (475-18,000; 5500 avg.)	NS	10-800 225 avg.	NS	NS	89	99	L	Calvert (1939) avg. 9 tests, 15 min sedimentation
Lake	Colony count (1358)	12.1	40	13	NS	46	72	F	Streeter (1929) avg. of 4 plants on Lake Erie.
Lake	<u>E. coli</u> , index (818)	12.1	40	13	NS	76	72	F	Streeter (1929) avg. of 4 plants on Lake Erie.

<sup>a</sup>Turbidity removal is expressed as a percentage unless otherwise stated.

<sup>b</sup>L - laboratory; P - pilot plant; F - full scale.

<sup>c</sup>NS - not stated.

widely quoted laboratory study by Chang and coworkers (1958a) reported bacterial removals of 99 percent or more, but these figures have not been substantiated in other reported data. Streeter (1927, 1929) reported bacterial removals of 46 to 83 percent at full-scale treatment plants. Cummins and Nash (1978) reported total coliform removals of 42 percent.

The lack of recent reports on the removal of bacteria by this process is probably due to the widespread reliance on prechlorination dating from the late 1930's and early 1940's, with the result that attention was diverted from the capability of coagulation for removing bacteria. With the recent interest in decreasing prechlorination of water to reduce trihalomethane concentrations, the potential that coagulation offers for removal of organisms takes on new importance. Additional studies are needed to determine the effects that variations in pH, coagulant type and dosage, temperature, and other water characteristics would have on the removal of different bacteria.

b. Removal of Viruses. Poliovirus 1 and coxsackievirus A2 are the only enteric viruses for which data on removal by coagulation and sedimentation are available [See Table E.2-2]. Several studies conducted at large pilot plants reported relatively high reductions from influent containing low virus titers [Table E.2-2]. These studies indicate that viruses present in relatively low concentrations should be reduced by approximately 90 percent or more with coagulation. Chang and coworkers (1958a,b) reported that variations in the type of coagulant and temperature had minor effects on the removal of coxsackievirus A2, although an increased coagulant dose did increase removal. Data from other investigators (Guy, et al., 1977) support the observation that there is little difference in virus removals between the use of  $\text{Fe}_2(\text{SO}_4)_3$ ,  $\text{FeCl}_3$ , or  $\text{Al}_2(\text{SO}_4)_3$ .

Although the coagulation process is relatively non-specific in its capacity to remove small particles, prudence dictates that generalizations based on tests made with only poliovirus 1 and coxsackievirus A2 be validated with studies using a spectrum of the enteric viruses.

c. Removal of Parasitic Protozoa and Metazoa. Cysts of protozoa and eggs of metazoa are heavier than bacteria and viruses and will settle in quiescent water. Helminth eggs are quite heavy and settle rather rapidly. The data

TABLE E.2-2

## REMOVAL OF ENTERIC VIRUSES BY COAGULATION AND SEDIMENTATION

Coagulant	Type of Water	Virus <sup>a</sup>		Conditions of Coagulation					Removal		Type Study <sup>d</sup>	Reference and Remarks
		Type	Initial conc. PFU/ml	Coagulant Dose (mg/ l or PPM)	Turbidity <sup>b</sup>	Temp. (°C)	pH Start End		Virus (%)	Turbidity <sup>c</sup>		
Al <sub>2</sub> (SO <sub>4</sub> ) <sub>3</sub>	Distilled	Polio 1 (Sabin)	3-7x10 <sup>4</sup>	10	50 mg/l clay	Room	NS <sup>e</sup>	6.8	90	97	L	Thorup, et al., (1970)
Al <sub>2</sub> (SO <sub>4</sub> ) <sub>3</sub>	River	Coxsackie A2	NS	25	16-240	25	NS	6.7-7.3	99	1-5 TU	L	Chang, et al., (1958a)
Al <sub>2</sub> (SO <sub>4</sub> ) <sub>3</sub>	River	Coxsackie A2	NS	25	140-255	15	NS	6.7-7.4	95	1-5 TU	L	Chang, et al., (1958a)
Al <sub>2</sub> (SO <sub>4</sub> ) <sub>3</sub>	River	Coxsackie A2	NS	25	40-135	5	NS	6.7-7.4	96	1-5 TU	L	Chang, et al., (1958a)
Al <sub>2</sub> (SO <sub>4</sub> ) <sub>3</sub>	Distilled	Coxsackie A2	2.25x10 <sup>5f</sup>	40	0.4 ml SiO <sub>2</sub>	25	6.2	6.2	86	NS	L	Chang, et al., (1958b)
Al <sub>2</sub> (SO <sub>4</sub> ) <sub>3</sub>	Activated sludge effluent	Polio 1 (Vaccine)	596	56	~10 FTU	29	7.1	6.8	63	~2.5 FTU	P	Wolf, et al., (1974) Al:P = .44 - 1

(REVISED FROM SPROUL, 1979)



TABLE E.2-2 -- Continued

Coagulant	Type of Water	Virus <sup>a</sup>		Conditions of Coagulation					Removal		Type Study <sup>d</sup>	Reference and Remarks
		Type	Initial conc. PFU/ml	Coagulant Dose (mg/ l or PPM)	Turbidity <sup>b</sup>	Temp. (°C)	pH Start End		Virus (%)	Turbidity <sup>c</sup>		
Al <sub>2</sub> (SO <sub>4</sub> ) <sub>3</sub>	Distilled	Coxsackie A2	2.25x10 <sup>5</sup>	60	0.4 ml SiO <sub>2</sub>	25	6.2	6.2	96	NS	L	Chang, <u>et al.</u> , (1958b)
Al <sub>2</sub> (SO <sub>4</sub> ) <sub>3</sub>	Distilled	Coxsackie A2	2.25x10 <sup>5</sup>	80	0.4 ml SiO <sub>2</sub>	25	6.2	6.2	97	NS	L	Chang, <u>et al.</u> , (1958b)
Al <sub>2</sub> (SO <sub>4</sub> ) <sub>3</sub>	Distilled	Coxsackie A2	2.25x10 <sup>5</sup>	100	0.4 ml SiO <sub>2</sub>	25	6.2	6.2	99	NS	L	Chang, <u>et al.</u> , (1958b)
Al <sub>2</sub> (SO <sub>4</sub> ) <sub>3</sub>	Activated sludge effluent	Polio 1 (Vaccine)	113	NS	3.4 FTU	22	7.3	6.9	99.7+	1.5 FTU	P	Wolf, <u>et al.</u> , (1974) Al:P = 7.1
Al <sub>2</sub> (SO <sub>4</sub> ) <sub>3</sub> + Calgon WT 3000	Activated sludge effluent	Polio 1 (Chat)	130	76 + 0.2	4.6	24	7.3	6.9	95 (avg.)	10	P	Anon (1977) Al:P = 1.7:1
FeCl <sub>3</sub>	River	Coxsackie A2	NS	15	5-10	25	NS	8.1-8.4	95	0.1 TU	L	Chang, <u>et al.</u> , (1958a)
FeCl <sub>3</sub>	Distilled	Coxsackie A2	4.5x10 <sup>3f</sup>	20	0.4 ml SiO <sub>2</sub>	25	6.2	6.2	97	NS	L	Chang, <u>et al.</u> , (1958b)

TABLE E.2-2 -- Continued

Coagulant	Type of Water	Virus <sup>a</sup>		Conditions of Coagulation					Removal		Type Study <sup>d</sup>	Reference and Remarks
		Type	Initial conc. PFU/ml	Coagulant Dose (mg/ l or PPM)	Turbidity <sup>b</sup>	Temp. (°C)	pH Start End		Virus (%)	Turbidity <sup>c</sup>		
FeCl <sub>3</sub>	Distilled	Coxsackie A2	4.5x10 <sup>3f</sup>	40	0.4 ml SiO <sub>2</sub>	25	6.2	6.2	98	NS	L	Chang, et al., (1958b)
FeCl <sub>3</sub>	Demineralized	Polio 1 (Mahoney)	1.4x10 <sup>6g</sup>	60	25 & 500 mg/l clay	15-17	5-8	NS	48-99.7	NS	P	Foliguet & Doncoeur (1975) poorer removal with low clay
FeCl <sub>3</sub>	Demineralized	Polio 1 (Mahoney)	10 <sup>6.3h-</sup> 10 <sup>8.37</sup>	66	45-178	13-21	7 - 7.7	6.6-6.9	99.7 - 99.999	0.6 - 3.8 TU	P	Foliguet & Michelet (1969)
Fe <sub>2</sub> (SO <sub>4</sub> ) <sub>3</sub>	River	Polio 1, 2, 3 (Glaxo oral vaccine)	9.2x10 <sup>7i</sup>	40	NS	NS	NS	NS	99.8	NS	P	Guy, et al., (1977)
Fe <sub>2</sub> (SO <sub>4</sub> ) <sub>3</sub>	River	Naturally occurring (mainly coxsackie B3 & B5)	.004 <sup>j</sup>	40	NS	NS	NS	NS	No virus detected > 88.3%	NS	P	Guy, et al., (1977)

TABLE E.2-2 -- Continued

Footnotes:

<sup>a</sup>Experimentally inoculated, except as indicated.

<sup>b</sup>Expressed as turbidity units (TU) except where indicated.

<sup>c</sup>Expressed as a percentage except where indicated.

<sup>d</sup>L - laboratory; P - pilot plant.

<sup>e</sup>NS - not stated.

<sup>f</sup>LD<sub>50</sub> per ml.

<sup>g</sup>MPN cytopathic units per ml.

<sup>h</sup>TCD<sub>50</sub> per ml.

<sup>i</sup>Infectious particles (single concentrated inoculum).

<sup>j</sup>Infectious particles per ml.

presented in Table E.2-3 indicate that the removal of parasitic protozoan cysts by coagulation and sedimentation should be 90 percent or more under optimum conditions.

d. Conclusions. The few reports available on removal of bacteria indicate that reductions will vary from 50 to 97 percent with coagulation carried out on a plant scale. Removal of parasitic cysts should exceed 90 percent, although this also is based on only a few reports. Additional studies, therefore, are needed to verify the removal efficiencies obtained with bacteria and parasitic cysts, especially as these are affected by variations in pH, coagulant type and dosage, temperature, and different quality waters.

The application of sufficient quantities of either ferric or aluminum salts should result in 90 to 99.999 percent reductions in enteric viruses. However, these predictions are based only on results from coagulation studies with poliovirus 1 and coxsackievirus A2 and should be confirmed by tests made with other representative enteric viruses.

### 3. Sand Filtration

One of the treatment processes often used for water purification is filtration through sand, soil, or dunes (Baker, 1934; Burman, 1962; Burman, 1978; Graveland and Hrubec, 1976; Kool, 1979; Robeck, et al., 1962). Filtration is a process whereby raw water is passed through a porous matrix to remove suspended and colloidal impurities and, frequently, to change the chemical characteristics of the water and reduce the levels of microorganisms present [See also Sections E.3 to 4 and G.2].

Removal of constituents from the water is accomplished by a combination of physical and biological processes, the most important of which are mechanical straining, sedimentation, adsorption, electrostatic binding, and microbial activity. Filtration through sand, as it is practiced today in drinking water treatment, can be divided into three types: rapid sand filtration, slow sand filtration, and dune or bank infiltration.

James Simpson is acknowledged as the first to introduce slow sand filtration into Europe, at the Chelsea Waterworks Company (one of the suppliers of London's drinking water at the time) in 1829. A cholera outbreak [See Section B.1.a(vii)]

TABLE E.2-3

## REMOVAL OF PARASITIC CYSTS BY COAGULATION WITH ALUMINUM SULFATE AND SEDIMENTATION

Type of Water	Organism		Conditions of Coagulation			Removal of Cysts (%)	Final Turbidity (TU)	Type Study	Reference and Remarks
	Species	Initial Conc. (cysts/ml)	Coagulant Dose (mg/l or ppm)	Turbidity (TU)	Final pH				
Gravel pit water	<u>Giardia muris</u>	NS	5	9	6.5	96	3.5	L	Arozarena (1977)
Gravel pit water	<u>Giardia muris</u>	NS	10, 25, 50	9	6.5	> 99.4 for each dose	0.5-1	L	Arozarena (1977)
Gravel pit water	<u>Giardia muris</u>	NS	25	NS	5	58	0.5	L	Arozarena (1977)
Gravel pit water	<u>Giardia muris</u>	NS	25	NS	6-9	> 90	0.2	L	Arozarena (1977)
Clear water	<u>Entamoeba histolytica</u>	135	30	"high"	NS	33	NS	L	Spector, <u>et al.</u> , (1934)
Clear water	<u>Entamoeba histolytica</u>	150	40	"high"	NS	40	NS	L	Spector, <u>et al.</u> , (1934)
Clear water	<u>Entamoeba histolytica</u>	150-230	60	"high"	NS	55	NS	L	Spector, <u>et al.</u> , (1934) (avg. of three tests)
Activated sludge effluent	<u>Entamoeba histolytica</u>	NS	1000	NS	NS	Effective removal (cultures were neg)	NS	L	Cram (1943)
NS	<u>Entamoeba histolytica</u>	1	NS	NS	NS	99.2	NS	P	Anon. (1944), as cited by Logsdon, <u>et al.</u> , (1978)

in Germany in 1892, involving water from the Elbe River, demonstrated the efficiency of this treatment in removing a pathogen. The outbreak occurred in Hamburg, where water of the Elbe was drunk untreated, but not in nearby Altona, where the water was drunk only after slow sand filtration.

This section discusses the physical and biological processes that are involved during sand filtration, the problems that may arise during operation, and the capacities of such a treatment for removing organisms. The concept of this presentation is based on a paper by Huisman and Wood (1974).

a. Physical Processes. Particles of suspended matter too large to pass through the interstices between the sand grains are removed by the action of mechanical straining. This process takes place almost entirely at the surface of the filter, where water first enters the pores of the filter bed. As filtration continues, pore openings become smaller from the deposition of suspended matter, enabling straining of progressively smaller particles. A mat eventually develops as more material accumulates on top of the filter bed, and this also increases the efficiency of the straining process. When flocculation occurs within the filtration bed, the aggregated particles may be retained at greater depths of the bed. Bacteria, viruses, other microorganisms, colloidal material, and other substances smaller than the pore spaces are not, however, removed by mechanical straining.

Sedimentation is largely responsible for the removal of colloids, small particles of suspended matter, and bacteria. Here, the interstices between the sand grains serve as minute sedimentation basins, along the sides of which suspended particles settle. Smaller and lighter particles are only partly removed, although flocculation accompanying further downward movement of the water will slightly increase sedimentation efficiency with depth. Truly colloidal matter cannot, however, be removed in this way.

Adsorption can take place in either of two ways. The simplest is when suspended particles collide with and adhere to the sticky gelatinous coating formed on the sand grains by previously deposited bacteria and colloidal matter. Of greater influence is the active promotion of adsorption by physical attraction between two particles of matter (Van der Waals forces), and still more important is the electrostatic attraction between opposite electrical charges (Coulomb forces) [See Section A.1.e].

b. Biological Processes. Biological activity is the action of microorganisms living on and in the filter bed which produce chemical and physical, as well as biological, changes in the quality of water. The protozoa, metazoa, and bacteria inhabiting the filter bed include many organisms (often in quite high numbers) not commonly detectable in the raw water [See Section A]. The intensity of their activity is a function of infiltration rate; that is, the slower the flow, the longer the detention and the more important becomes the role of the filter bed flora in the treatment process. Biological activity, therefore, counts heavily in slow sand filtration and artificial recharge. In these systems, the greatest biological activity occurs near the filter surface (Kool, 1976). Their influence on the physical, chemical, and biological properties of the water arises mainly from activities of nutrient utilization and predation.

(i) Nutrient Utilization. Many bacteria and fungi in the filters are able to derive needed energy and nutrients from the numerous organic compounds, of various origins, that are dissolved in the raw water. These compounds are incorporated into cell mass, degraded to intermediate compounds, or mineralized entirely to carbon dioxide, water, and inorganic salts. Some organic compounds are less readily utilized than others by microorganisms in the filter bed. On the other hand, some bacteria can adapt rather quickly to new compounds to which they were not previously exposed. This has been demonstrated with various phenols. Within a few days after exposure to 8 to 10 mg per liter of phenols added to the raw water, organisms in the slow sand filter had adapted so as to be able to metabolize and remove all of the phenol (Metropolitan Water Board, 1971-1973a). Organic compounds present in raw water are usually pollutants and action upon them by the filter bed flora inevitably results in improved water quality (Zwaagstra, 1978).

(ii) Predation. The development of a large mixed microbial flora in response to organic nutrients present in the raw water results in the growth of predators. The antagonism between predators and nutrient utilizers does not, however, reduce the activity of nutrient utilizers. On the contrary, it is more likely to maintain an ecological equilibrium that stabilizes the activity of all the organisms in the community (Waksman, 1937).

Predators may include bacteriophages, the bacterium Bdellovibrio bacteriovorus, protozoa (including amoebae, flagellates, and ciliates), and metazoa such as rotifers and the larger oligochaetes (Metropolitan Water Board, 1971-1973a; Reijnen, 1973) [See also Sections A.2, B.3, and E.1]. Bacteriophages, like other viruses, require living and growing host cells, in which to replicate, and this results in the lysis of the host cell. The tiny bacterium Bdellovibrio makes use of its very active motility to embed itself in the host bacterium where it multiplies, causing lysis of the host cell. It has been found in sewage effluent, surface waters, filter beds, and soil (Reijnen, 1973). It is not known whether protozoan predation significantly alters bacterial numbers and activity in slow sand filters (Dor-nedden, 1930; Reijnen, 1973).

All of these predators feed primarily on the saprophytic microorganisms growing in the filter bed, but also will feed on intestinal bacteria and other organisms of public health significance that may be present and thereby improve the bacteriological quality of the raw water.

(iii) Effect of Temperature. Every microorganism grows best at its own optimum temperature [See Section B.3]; mixed communities in an aquatic environment probably exhibit optimum activity at around 20 to 30°C. At higher temperatures, there is less diversity of species, whereas lower temperatures retard metabolic rates and hence, growth and activity. It follows that during prolonged cold weather, slow sand filters will be less effective, as is evidenced in temperate regions where the chemical and bacterial quality of the filtrates changes with the seasons. This suggests that slow sand filters would be less effective in countries with extremely cold and prolonged winters, not to mention problems of cleaning beds during freezing weather.

Temperature exerts a great influence over the fate of pollutants, as in the case of ammonia. Ammonia can be utilized by some bacteria as an energy source. Nitrosomonas oxidizes ammonia to nitrite and Nitrobacter oxidizes nitrite to nitrate [See Section A]. This process is dependent on temperature and slows rapidly below 6°C (Huisman, unpublished data) even after only a short period of exposure; for example, when beds are drained for cleaning during a cold night, the ammonia oxidizing capacity takes several weeks to recover.



c. Rapid Sand Filtration. Flow rates during filtration are usually measured linearly as the vertical flow of water from the top, down through the sand. Rapid sand filters are ordinarily filled with medium to coarse sand (grain size 0.5 to 1.5 mm or larger) and have vertical flow rates of 5 to 10 m per h for free surface filters, and up to approximately 20 m per h for pressure filters enclosed in watertight steel cylinders. Impurities in the water are deposited deep in the bed of a rapid sand filter because of the high flow rates and the large size of the sand grains. The rapid clogging that results from the high flow rates necessitates cleaning at intervals of hours to a few days (Graveland and Hrubec, 1976).

d. Slow Sand Filtration. With slow sand filtration, water is passed down by gravity through a constructed layer of fine sand (usual grain size of 0.15 to 0.4 mm). Filtration rates vary from about 0.1 to 0.4 m per h, although rates of up to 0.8 m per h have been used experimentally (Metropolitan Water Board, 1971-1973a). After a few weeks to a few months of operation (depending on the quality of the raw water), particulates that have accumulated on and in the bed will begin to reduce the flow so that filtration rates cannot be maintained. However, because the sand is fine, clogging takes place only at the very top of the sand, and cleaning is accomplished simply by removing the top 1 to 3 cm of sand.

e. Artificial Recharge. With artificial recharge, water is passed through naturally occurring dunes or river banks at flow rates lower than those obtained with slow sand filtration. For example, in the Netherlands, water is infiltrated through dunes at velocities of up to 0.2 m per day and through river banks at rates of 0.1 to 0.5 m per day (Graveland and Hrubec, 1976). At times, detention of the infiltrated water may be very prolonged, and anaerobic conditions may develop, leading to the microbial production of off flavors and odors. As with slow sand filtration, particulate matter gradually accumulates on and in the filter bed, reducing flow rates; hence, beds must be cleaned periodically (every two to five years for dune infiltration) by the same procedure carried out for slow sand filters.

f. Characteristics of the Raw Water. The biological nature of dune, bank, and slow sand filtration implies that

some organic content is required in the water to encourage the necessary bacterial population to bring about purification. The methods are, therefore, unlikely to be satisfactory with waters that contain no organic matter and where all turbidity is due to mineral matter. Raw waters high in turbidity due to suspended mineral matter and low in dissolved organic substances are unlikely to be much benefitted by these processes. Neither is it advisable, in the case of dune and slow sand filtration, to filter highly turbid waters without some preliminary treatment to avoid the need for frequent cleaning. Dune and slow sand filtration can best be employed in a dual arrangement of preliminary filtering through a conventional rapid sand filter. The higher quality water obtained from this primary filtration extends the cleaning interval required for subsequent slow sand filters and should enable faster filtration rates without significant silt penetration.

g. Algal Growth. Algae can cause filtration problems. Growth of unicellular algae in storage reservoirs [See Section E.1] results in an increase in particulate matter which has to be removed either on the primary or secondary filters, or both. From the filtration management standpoint, this requires more frequent cleaning and backwashing of filters, particularly the primary ones. Algae can also grow in uncovered filters or filter beds which are exposed to light, especially filamentous algae during the summer months (Metropolitan Water Board, 1967-1968). Even when a good quality water is infiltrated, algal growth is supported if the water contains a high phosphate load, especially with a rapid infiltration rate (Hrubec, 1975). Where filamentous algae are a problem, they must be removed promptly when a filter is drained for cleaning, lest they begin to compost and raise temperatures sufficiently to support growth of undesirable organisms such as E. coli (Metropolitan Water Board, 1969-1970a).

The temperature and the phosphate content of raw water usually are not subject to control, but all algal growth on filters can be prevented by excluding light. A roof or shade may suffice; however, a completely enclosed building over the filters offers the further advantages that it permits the filters to be cleaned even during extremely cold or wet weather and that it excludes birds that might pollute the filters (Graveland and Hrubec, 1976; Metropolitan Water Board, 1969-1970b and 1971-1973a) [See Section F.1.b].

h. Maintenance of a Steady State. It should be clear from the foregoing that dune, bank, and slow sand filtration are unique ecological systems of which the microbial types and distribution are subject to change with changing conditions, especially changes in filtration rate and raw water quality.

Sudden changes in filtration rates can cause deterioration in efficiency [See also Section G.2]. This is because, with very slow filtration, most microbial degradation and removal of nutrients takes place in the upper layers; whereas, with faster rates, nutrients penetrate deeper and consequently, microbial activity occurs at greater depths. Any abrupt rate change would remove nutrient deposition away from access by the established filter bed flora.

Another cause of perturbation is leaving the filter bed full of water when it is not in operation. At very slow flow rates, or when there is no flow, the demand inherent to the system can use up all available oxygen, causing a drastic change in the microbial flora and resulting in the production of some objectionable compounds.

When a bed is drained for cleaning, the bacterial micro-environment changes completely. Instead of receiving a steady flow of water containing nutrients, the interstices of sand become filled with air. Bacterial metabolism becomes more oxidative, and bacterial gums and other attachment substances are used as nutrient sources. Bacteria that previously were attached to the sand grain surface tend to be released so that when filtration recommences, they are washed out into the filtrate (Metropolitan Water Board, 1969-1970a). The longer the interruption in filtration and the higher the temperature, the greater the contamination of the filtrate. It is important, therefore, that beds be kept out of use for cleaning for as short a period as possible, especially in the summer months, and that former filtration rates be resumed as soon as possible. Beds returned to use at their maximum filtration rates within 24 h show no deterioration in efficiency (Metropolitan Water Board, 1971-1973a).

i. Removal of Microorganisms by Dune, Slow, and Rapid Sand Filtration. Sand filtration of water removes microorganisms by physical and biological processes as has already been discussed. Filtration and adsorption were studied to determine their influence on virus retention (Goldschmid, et al., 1972; Lefler and Kott, 1974). Adsorption on sand

was found to be strongly enhanced in the presence of cations, such as those of calcium and magnesium, and fresh sand was demonstrated less retentive of viruses than conditioned sand. Viruses could be eluted from the particles by raising the pH or by reducing the ionic strength of the water (Goldschmid, et al., 1972; Lefler and Kott, 1974; Nestor and Costin, 1971; Wellings, et al., 1975) [See Section A.1.e].

A dune infiltration system in the Netherlands was examined for its capacity to remove bacteria and viruses (Hoekstra, 1978; Kool, 1978). Tests in which raw surface water was infiltrated through sand dunes produced the following results: > 99.99 percent of the colony count (at 22 and 37°C), > 99.9 percent of coliphages, and > 99 percent of thermo-tolerant and total coliforms were removed. The somewhat lower percentages for coliphage and coliform removal, compared to that of the colony count, were due to a relatively small number of coliphages and coliforms present in the raw water before filtration. None of these organisms were detected in samples of 1,000 and 100 ml after filtration. Therefore, it is likely that coliphages and coliforms would exhibit the same high removal rates as those obtained for the colony counts. These high removals of > 99.99 percent are in agreement with Robeck and coworkers (1962) who observed that seepage through unsaturated sand reduced poliovirus levels by > 99.99 percent. The capacity of slow sand filtration to remove viruses was investigated by Robeck and coworkers (1962) who obtained a 96 percent removal of poliovirus. Poynter and Slade (1977) also showed that this process was efficient for removing enteroviruses.

Factors that adversely affect removal of microorganisms during sand filtration are low temperatures, high flow rates, insufficient sand depth, and filter immaturity. The importance of temperature was demonstrated by Burman (1962) who reported that during cold weather, only 41 percent of E. coli and 88 percent of total coliforms were removed by slow sand filtration. Poynter and Slade (1977) reported that the lowest poliovirus reduction of 98.25 percent was obtained at 5°C and at a flow rate of 12.0 m per day; whereas, at a standard rate of 4.8 m per day and at 11°C, poliovirus was reduced by 99.999 percent [See also Sections B.1.b, B.1.d, and C.2.b].

Bacteria are not retained quite as efficiently as are the enteric viruses in slow sand filters. Total coliforms were reduced by 96.3 to 99.5 percent, and slightly lower

reductions were obtained for E. coli and colony counts at 22°C (reductions of the colony count at 37°C were lower yet). Results from a 12-year study of slow sand filtration showed that reductions in total coliforms and colony counts varied from 70 to 98 percent when an infiltration rate of 5 m per day was used (Hoekstra, 1978) [See also Sections C.1 and D].

Only marginal reductions of microorganisms are possible with rapid sand filtration. Robeck and coworkers (1962) showed that not more than 50 percent of polioviruses could be removed with this step, and in other studies removal of enteric viruses and bacteriophages fluctuated between 0 and 98 percent (Berg, et al., 1968; Guy, et al., 1977).

Less information is available on the removal during infiltration of pathogenic protozoa such as Entamoeba histolytica and Giardia lamblia, and metazoan parasites such as Ascaris lumbricoides and Schistosoma. Results of Baylis (1936) and a review in the report of the Safe Drinking Water Committee (1977) indicate that most of these organisms can be removed by sand filtration, although Rivas (1967) reported that, in some cases, sand filters do not remove Schistosoma cercariae. Nevertheless, mechanical means of clarifying water, such as sand filtration, are important as antiparasitic measures, especially when one considers that the protozoan cysts are resistant to usual residual chlorine concentrations maintained in the distribution system [See Section B.1.c].

j. Conclusion. When the available data on the various sand filtration processes are compared, it becomes clear that artificial recharge in the ground, through river banks and in sand dunes, is one of the most effective treatments for removing microorganisms from raw water. Slow sand filtration is also well suited for removing enteric viruses and is slightly less so for bacteria.

The efficiency of water purification in slow sand filters is a function of raw water quality and is adversely affected by low temperatures, excessive flow rates, inadequate sand depths, and immaturity of the filter. The mechanisms by which bacteria and viruses are removed in the sand are not yet clear, but both organisms seem to respond in the same way to the cleaning process, whereby the viruses are removed more efficiently than the bacteria. Rapid sand filtration is not efficient enough to serve alone for the

removal of viruses and bacteria, thus, it should be used only in combination with other treatments, such as slow sand filtration and flocculation.

Areas with the needed soil configurations or the requisite land area and sand to build filters, would find artificial recharge or slow sand filtration a very simple, practical, reliable, and inexpensive method for removing microorganisms from raw water. The level of efficiency falls, however, in cold climates.

#### 4. Activated Carbon Filtration

Activated carbon filtration has proved to be extremely useful for the treatment of drinking water and is almost indispensable with water from surface sources. However, the microbiological quality of water treated by activated carbon filtration has often failed to meet legal requirements because of high colony counts measured by the German Standard Procedures. Bacteria can actively contribute to the improvement of water quality during activated carbon filtration [See the reports of Project Area II: Advanced Treatment Technology]. The microbiology of activated carbon filtration for the treatment of drinking water is poorly understood because testing, to date, has been done according to German Standard Methods that were devised to guarantee safe water rather than to characterize the microbial community.

The present discussion addresses the numbers, kinds, and metabolic activities of bacteria in activated carbon filters for drinking water. The numbers of microorganisms can be determined accurately only by separating them from the carbon (e.g., with a standard household mixer) and culturing them on a rich medium incubated at 25°C for seven or more days to accommodate the long generation times of some of them. Bacteria, in a study by Klotz and coworkers (1976), were identified according to Bergey's Manual of Determinative Bacteriology (Buchanan and Gibbons, 1974). The metabolic activities of the bacteria were assessed by comparison of a sterile and a nonsterile activated carbon filter. Biocidal substances were not effective, so activated carbon filters were autoclaved and operated with filter-sterilized water. The activities of the bacteria could not be determined solely on the basis of CO<sub>2</sub> production or O<sub>2</sub> consumption during the passage of the water through the filter beds because some purely chemical oxidation of organic substances adsorbed to active carbon also takes place.

a. Numbers and Kinds of Microorganisms. It proved impossible in practice to produce, by means such as the use of silver-impregnated carbon or frequent back-washing of filters, water that had low enough colony counts to meet German Standards after activated carbon treatment. Colony counts in the activated carbon filters examined ranged from  $10^7$  to  $10^8$  bacteria per g of wet material and were stable for several years if the treatment processes remained unchanged. Bacterial numbers were a function of the treatment processes, especially those affecting the degradability of organic substances. Bacterial numbers were minimally affected by the use of different types of activated carbon and apparently not at all by seasonal variations, including changes of temperatures between  $5^\circ$  and  $25^\circ\text{C}$ .

The activated carbon filtrate gives colony counts of about  $10^4$  per ml of water, but is otherwise satisfactory when examined according to the German Standard Methods. Activated carbon filters can be compared to chemostats in that the rate of flow has a direct influence on microbial development.

Although numbers of bacteria found on the activated carbon and in the filtrate were relatively constant, the proportions of organisms in each of the two phases are governed by events occurring on the boundary surfaces of the water-carbon system. Examination by scanning electron microscopy reveals that the space on the carbon surface is only partially occupied by bacteria. In the middle range of concentrations, the adsorption of bacteria is governed by the isotherm equation of Freundlich. The equilibrium of adsorption in a beaker in the laboratory is reached only after 24 h and is influenced by the ionic composition of the aqueous phase and by whether the bacteria are dead or alive, but evidently not by variations of temperatures normally encountered in drinking water treatment.

A great variety of bacteria, among which 26 species from 12 genera could be identified, was found in the activated carbon filtrate. As expected, most species identified, was found in the activated carbon filtrate. As expected, most species identified belonged to the genus *Pseudomonas*, which is characterized by a very adaptable metabolism [See also Sections A.2.a to b, B.1.a(ix), C.2.c, F.2.a, and F.3]. Next most prevalent was the genus *Bacillus*. Fungi and yeasts are encountered only rarely and do not seem to be of any importance.

b. Microbial Metabolism on Activated Carbon and Its Effects on Water Quality. Activated carbon adsorbs organic substances and desorbs them slowly, so they serve as a sustained source of nutrients for bacteria associated with the carbon. The resulting stimulation of bacterial growth apparently increases with increasing diameter of the carbon grains, negating the adverse effect of the reduction in surface area that goes with larger grain size. Adsorption increases the local concentration of the organic substances, which enhances the probability that they will be degraded. Even substances toxic to the bacteria are more susceptible to biological degradation once they have been adsorbed to the carbon.

Most of the organic substances removed in treating water by activated carbon filtration are removed by adsorption rather than biological degradation. In a recent study, the total reduction of organic substances (measured by COD,  $\text{KMnO}_4$ -reaction, and UV-adsorption) by non-sterile activated carbon filtration was found to be 80 percent (while the material still had very nearly its initial high adsorptive capacity) of which the part attributable to bacterial activity was approximately 4 percent. As the adsorptive capacity of the carbon declines with use, the part of removal of organics attributable to bacterial activity rises considerably. The changes of  $\text{O}_2$  and  $\text{CO}_2$  content that take place during filter passage are mainly produced by bacteria; only one-third is caused by purely chemical reactions.

Bacteria act most efficiently upon the most easily degraded substances: 60 percent of the removal of easily degradable substances (expressed as  $\text{BOD}_2$ ) is effected by bacteria, whereas only 17 percent of the more resistant substances (expressed as  $\text{BOD}_{20}$ ) is degraded by bacteria. It is important that the more easily degradable substances be eliminated by bacteria, for the biologically active carbon filter quite effectively eliminates substances which can give rise to aftergrowth within the distribution system [See Section F.2]. In addition, bacterial activity produces something of a regeneration of the carbon, thus prolonging the period of its usefulness. In general, the microbiological degradability of organic substances will be diminished by chlorination and enhanced by ozonation [See Section F.2.a].

c. Conclusions. The bacterial activity that takes place in activated carbon filters is supported by organic substances adsorbed to the carbon (Klotz, 1978; Klotz, et al., 1975, 1976a, 1976b; Werner, 1978, 1979). The more



readily degradable substances are used by the bacteria in the filters, extending the useful life of the carbon and reducing the capacity of the treated water to support microbial aftergrowth during distribution. A suggested adverse effect on consumer health, from bacteria and their derivatives in the treated water, has yet to be substantiated.

## 5. Disinfection

a. Chlorination. Since the beginning of the 20th century, chlorine has been one of the most widely used and thoroughly studied of chemical oxidants employed in drinking water disinfection. This paper discusses the various reactions between chlorine and water constituents, in terms of the important parameters governing these reactions and their ultimate effects on microorganisms. Also described is the mechanism by which chlorine acts upon the biota present in water.

(i) Chlorine Dissociation in Water. Chlorine, when added to water in the gaseous state or as sodium hypochlorite, initially hydrolyzes to form hypochlorous acid:

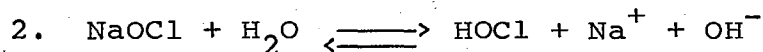
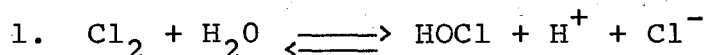

At pH 5, all chlorine occurs as hypochlorous acid, but as the pH increases, more hypochlorous will dissociate forming hydrogen and hypochlorite ions. Below pH 5, and at a concentration of > 1,000 mg per l, chlorine may be present in the elemental state ( $\text{Cl}_2$ ) (White, 1972). The chemical species thus formed --  $\text{Cl}_2$ , HOCl, and  $\text{OCl}^-$ -- are called free residual chlorine and their occurrence in water can be summarized as:

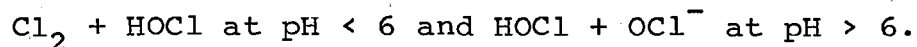

Temperature affects the equilibrium of the reaction, as expressed by the dissociation constant (KD) according to the following relation:

$$\text{KD} = 2.6 \times 10^{-8} \text{ mole per l at } 10^\circ\text{C}$$

$$\text{KD} = 3.7 \times 10^{-8} \text{ mole per l at } 25^\circ\text{C}$$

Thus, a rise in temperature increases the dissociation of hypochlorous acid.

Depending on the level and nature of pollution in a water supply, chlorine will react partially or totally, by oxidation or substitution, with organic and inorganic constituents of the water. In the case of iron, for example, chlorine reacts with ferrous ion and converts it to the ferric form:

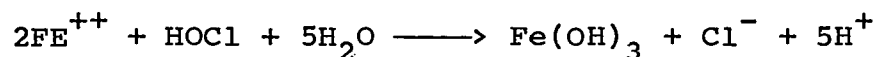

Soluble manganese compounds are similarly oxidized:

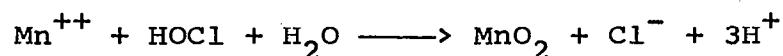

Both of these metal compounds will precipitate out. With anions such as nitrites, sulfides, and sulfites, the following reactions take place:

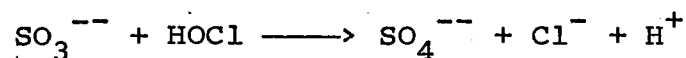
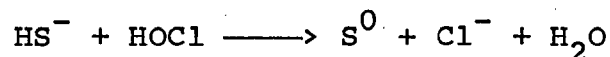
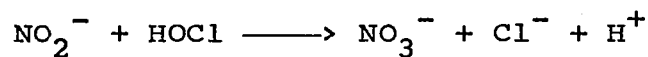

At pH's > 8, chlorine occurs principally as hypochlorite ions and gives the following reactions:

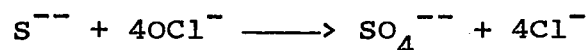

Ammonia reacts with chlorine to produce inorganic chloramines according to a sequence of reactions that begins (at pH's up to 8.3) with the formation of monochloramines:

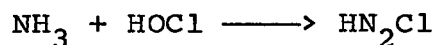

The second stage proceeds as an equilibrium reaction between mono and dichloramine:

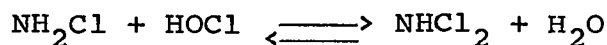

Finally, trichloramine is formed in the third stage:

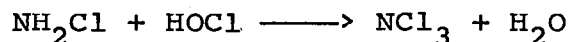

These reactions are dependent on pH, temperature, contact time, and the initial ratio of chlorine to ammonia. Chloramines will convert to form elemental nitrogen if the ratio

of chlorine to nitrogen exceeds 7.6:

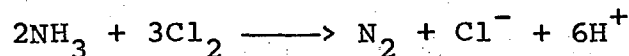

and in some cases, nitrates will, instead, be the product formed.

Organic chemicals with functional groups similar to ammonia (e.g., urea, amino acids, proteins, and other amines) react with chlorine to produce organic chloramines:

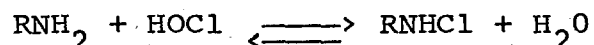

Chlorine linked with nitrogen is called combined residual chlorine. The sum of free residual chlorine ( $\text{HOCl}$  and  $\text{OCl}^-$ ) and combined residual chlorine determines the total residual chlorine; it is this total residual chlorine that constitutes the germicidal potential available in chlorine disinfection.

All of these reactions may occur in succession during water treatment [See Figure E.5.a-1]. Zone 1 of the curve in Figure E.5.a-1 occurs with low quantities of chlorine added to water. Here, chlorine will combine immediately with reduced mineral compounds. Higher chlorine inputs result in the formation of chloramines and some organo-chlorinated compounds (Zone 2). Further addition of chlorine causes a loss in total residual chlorine due to the oxidation of chloramines (Zone 3). When sufficient chlorine has been added to react with all the chlorine-consuming chemicals in the water, the breakpoint will be reached, during and after which chlorine forms free residual chlorine, the same as would occur in pure water (Zone 4). Reactions with other chemical constituents of a particular water source that may lead to the formation of toxic or even carcinogenic compounds are discussed in Project Area IIA of this Pilot Study.

(ii) Parameters Affecting the Disinfection Efficiency of Chlorine. How efficiently chlorine will disinfect depends on the microbial composition of the water, the chlorine dose applied, the contact time, and the chemical form taken by the chlorine. The chemical form of chlorine, in turn, depends on the pH and temperature of the water, along with the amounts and types of dissolved organic and inorganic substances present.

FIGURE E.5.a-1

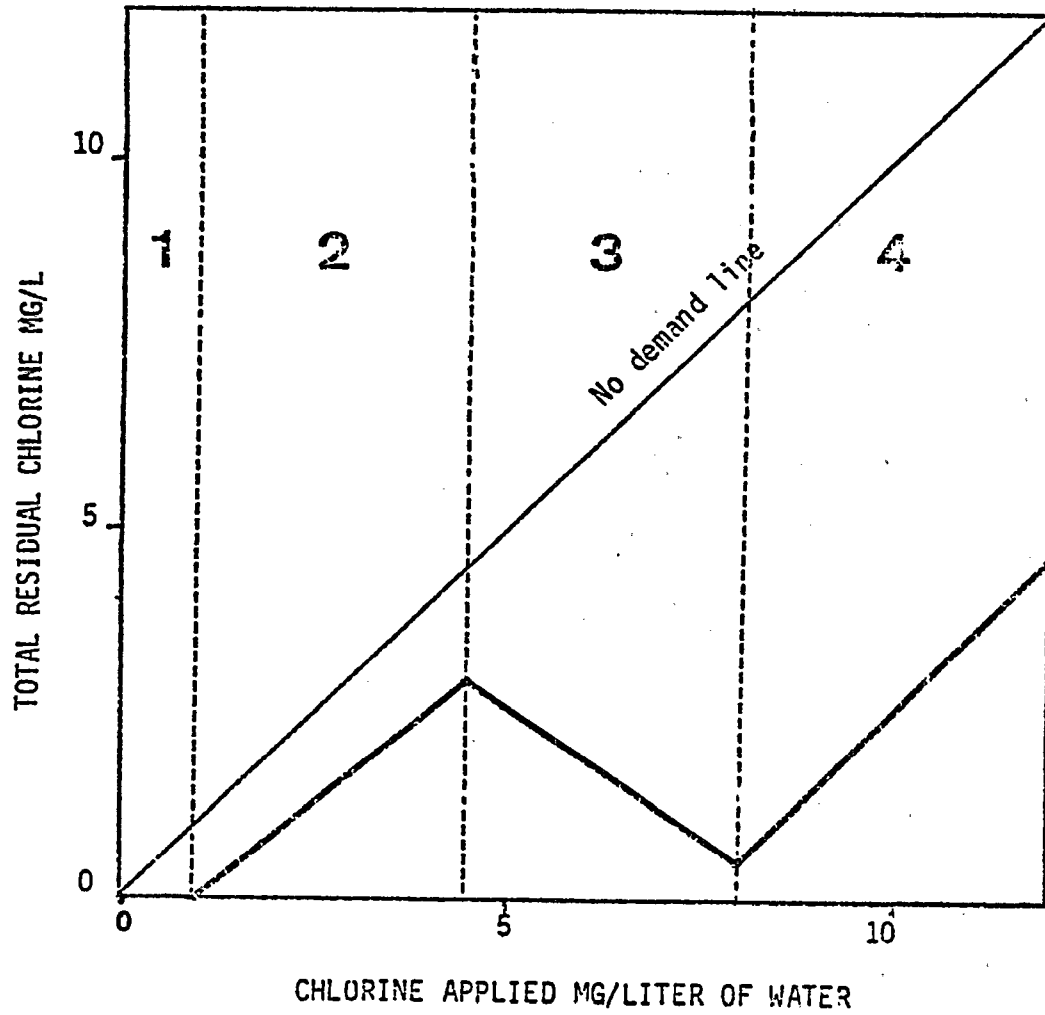
DIAGRAMMATIC REPRESENTATION OF COMPLETED  
BREAKPOINT REACTION

The following discussion takes into account only that chlorine which occurs as a residual during and after breakpoint chlorination. These chemical forms exert different germicidal effects. Feng (1966) proposed the following order of disinfecting efficiency:

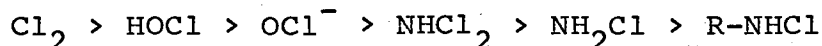

Morris (1967) measured the effects of HOCl, OCl<sup>-</sup>, and NH<sub>2</sub>Cl on various microorganisms and constructed a table of 1e<sup>-2</sup> thality coefficients for making comparisons [See Table E.5.a-1]. His results reiterated that HOCl > OCl<sup>-</sup> > NH<sub>2</sub>Cl. These studies confirmed earlier results of Butterfield and coworkers (1943) who found that at pH 10.7, when most of the chlorine would dissociate to form hypochlorite ion, a 60-fold increase in contact time was required to inactivate *E. coli* and *S. typhi* over that required at pH 7, when the greater fraction of chlorine would be HOCl. In similar studies, it was found that increasing the pH from 7 to 8.5 for poliovirus 1 (Weidenkopf, 1958) and from 8.8 to 9 for adenovirus 3 (Clarke, et al., 1956) extended the inactivation time sixfold.

Although the bactericidal and virucidal superiority of HOCl over OCl<sup>-</sup> has since been demonstrated by others (Engelbrecht, et al., 1978; Scarpino, et al., 1974), inconsistent results were obtained with poliovirus (Scarpino, et al., 1974) which were thought to be due either to direct effects of pH (Morris, 1970) or to the presence, in the medium, of mineral ions (Engelbrecht, et al., 1978; Kuzminski, et al., 1970). Indeed, Engelbrecht and coworkers (1978) have shown that the presence of potassium chloride accelerated poliovirus 1 inactivation by hypochlorous acid. Because, unlike the poliovirus, *E. coli* inactivation by hypochlorite ions was not enhanced in the presence of potassium chloride, it would seem likely that it is the potassium chloride, more than the hypochlorite ions, that was responsible for producing greater poliovirus inactivation.

It is commonly agreed that chloramines are less effective disinfectants than free chlorine against bacteria (Butterfield, 1948; Esposito, et al., 1974; Siders, et al., 1973), viruses (Esposito, et al., 1974; Lothrop and Sproul, 1969; Siders, et al., 1973) [See Table E.5.a-2], and protozoan cysts (Chang, 1971b; Stringer, et al., 1975). Moreover, the organic chloramines disinfect even less efficiently than the inorganic chloramines (Feng, 1966; Kjellander and Lund, 1965; Nusbaum, 1952). Hence, for optimal disinfection,

TABLE E.5.a-1

LETHALITY COEFFICIENTS FOR DIFFERENT MICROORGANISMS  
BASED ON TREATMENT WITH FREE AND  
COMBINED CHLORINE AT 5°C

Oxidant	Enteric Bacteria	Protozoan Cysts	Virus	Bacterial Spores
HOCl	20	0.05	1.0	0.05
OCl <sup>-</sup>	0.2	0.0005	0.02	0.0005
NH <sub>2</sub> Cl	0.1	0.02	0.005	0.001

From Morris, 1967.

TABLE E.5.a-2

DOSAGES OF VARIOUS CHLORINE SPECIES REQUIRED TO INACTIVATE 99% OF ESCHERICHIA COLI AND POLIOVIRUS 1

Test Microorganism	Chlorine Species	Concentration mg/l	Contact Time min	c.t. <sup>a</sup>	pH	Temperature °C	References
<u>E. coli</u>	Hypochlorous acid (HOCl)	0.1	0.4	0.04	6.0	5	Scarpino, <u>et al.</u> , 1974
	Hypochlorite ion (OCl <sup>-</sup> )	1.0	0.92	0.92	10.0	5	Scarpino, <u>et al.</u> , 1974
	Monochloramine (NH <sub>2</sub> Cl)	1.0	175.0	175.0	9.0	5	Siders, <u>et al.</u> , 1973
		1.0	64	64.0	9.0	15	Siders, <u>et al.</u> , 1973
		1.2	33.5	40.2	9.0	25	Siders, <u>et al.</u> , 1973
	Dichloramine (NHCl <sub>2</sub> )	1.0	5.5	5.5	4.5	15	Esposito, <u>et al.</u> , 1974
<u>Poliovirus 1</u>	Hypochlorous acid (HOCl)	1.0	1.0	1.0	6.0	0	Weidenkopf, 1958
		0.5	2.1	1.05	6.0	5	Engelbrecht, <u>et al.</u> , 1978
		1.0	2.1	2.1	6.0	5	Scarpino, <u>et al.</u> , 1974
	Hypochlorite ion (OCl <sup>-</sup> )	0.5	21	10.5	10.0	5	Engelbrecht, <u>et al.</u> , 1978
	Monochloramine (NH <sub>2</sub> Cl)	10	90	900	9.0	15	Siders, <u>et al.</u> , 1973
		10	32	320	9.0	25	Siders, <u>et al.</u> , 1973
	Dichloramine (NHCl <sub>2</sub> )	100	140	14,000	4.5	5	Esposito, <u>et al.</u> , 1974
		100	50	5,000	4.5	15	Esposito, <u>et al.</u> , 1974

<sup>a</sup>Concentration of compound multiplied by contact time (mg/l) (min).

free chlorine should be present in the water. Free chlorine, inorganic chloramines, and organic chloramines all have their own characteristic oxidation potentials, which also affects the efficiency of disinfection [See Table E.5.a-3].

Chlorine may be applied at the end of the treatment process so that a residual will be maintained throughout the distribution system. In this way, aftergrowth is prevented [See Section F.2.a] and as long as the residual remains detectable, it ensures that no contamination has occurred during distribution. As yet, no alternative has been found to provide an equivalent measure of protection during distribution [See also Project Area IIA].

(iii) Effects of Chlorine Dose and Contact Time on Disinfection Efficiency. The relationship of the concentration of free available chlorine to the time required for destroying a certain portion of microorganisms is expressed by the empirical equation:

$$c^n t_p = k$$

where  $c$  = disinfectant concentration,  $t_p$  = the time required for obtaining a constant percentage destruction of microorganisms,  $n$  = the Van't Hoff order of the reaction (or coefficient of dilution), and  $k$  = a calculated constant that represents an organism's relative resistance to a given disinfectant. For example, Fair and coworkers (1968) calculated values for an elimination of 99 percent of an initial population by HOCl (for which  $n = 0.86$ ):

$$c^{0.86} t_p = 6.3 \text{ for coxsackievirus A2}$$

$$c^{0.86} t_p = 1.2 \text{ for poliovirus 1}$$

$$c^{0.86} t_p = 0.098 \text{ for adenovirus 3}$$

$$c^{0.86} t_p = 0.24 \text{ for } \underline{E. coli}$$

When  $n$  is  $> 1$ , the efficiency of the disinfectant decreases rapidly with dilution. When  $n < 1$ , the efficiency of disinfection is based principally on contact time. When  $n = 1$ , the efficiency of disinfection is based equally on concentration and contact time.

It is difficult to review the literature for this type of information because of insufficient reporting of experimental conditions. However, from more recently published



TABLE E.5.a-3

## THE OXIDATION-REDUCTION POTENTIAL OF CHLORINE IN WATER

Reaction	Redox Potential at 25°C
$\text{Cl}_2 + 2\text{e}^- \rightleftharpoons 2\text{Cl}^-$	+ 1.39 V
$\text{HOCl} + \text{H}^+ + 2\text{e}^- \rightleftharpoons \text{Cl}^- + 2\text{H}_2\text{O}$	+ 1.49 V
$\text{OCl}^- + 2\text{H}_2\text{O} + 2\text{e}^- \rightleftharpoons \text{Cl}^- + 2\text{OH}^-$	+ 0.94 V

accounts in which data were expressed as concentration x contact time (C x t) [See Table E.5.a-2], it can be seen that the different forms of chlorine vary markedly in their abilities to inactivate E. coli and poliovirus 1.

(iv) Sensitivity of Microorganisms to Chlorine. Under ideal conditions, the destruction of a microbial population theoretically can be predicted on the basis of Chick's law (Morris, 1975), given that one disinfectant unit acts on one single target site. This relation is written:

$$N = N_0 C^{-at}$$

where N is the number of surviving microorganisms;  $N_0$  is the initial number of microorganisms; a is the slope of the inactivation curve; and t is the contact time. However, in practice, discrepancies between laboratory experiments and field assays have been noted with vegetative bacteria (Carson, et al., 1972), bacterial spores (Bond, et al., 1973), E. histolytica (Stringer, et al., 1975), and laboratory and indigenous enteroviruses (Block, et al., 1978). It would seem possible, therefore, that factors such as aggregation, adsorption, and microbial resistance to a disinfectant, acquired over time, might limit the usefulness of calculations when applying Chick's law.

Bacteria may aggregate in the presence of naturally occurring polysaccharide polymers (Harris and Mitchell, 1975) or they may adsorb to hydroxides in the water (Carlson, et al., 1975). Moreover, viral particles have been shown to aggregate spontaneously in distilled water (Floyd and Sharp, 1977) or in the presence of di- or trivalent ions (Floyd and Sharp, 1978). This clumping of bacteria (Carlson, et al., 1975; Poynter, et al., 1973) and viruses (Berg, 1964) limits diffusion of the oxidant, thereby decreasing the disinfection rate (Sharp, et al., 1975), which could explain the persistence of infectious particles in treated water (Engelbrecht, et al., 1978; Lovtsevich, 1973).

Turbidity also limits disinfectant action because microorganisms will adhere to suspended matter (Hoff, 1978). E. coli persisted several hours in turbid water to which chlorine had been added (Tracy, et al., 1966). Likewise, adding bentonite decreased the chlorine inactivation of coliphage MS<sub>2</sub> (Stagg, et al., 1977), although decreased disinfectant efficiency was not observed when kaolinite and aluminum oxide were tested with coliphage T7 and poliovirus 1 (Boardman and Sproul, 1977) [See also Sections C.2.a to b].

Beside the enhanced resistance to disinfectants afforded bacteria and viruses that are adsorbed to suspended matter or aggregated in clumps, sensitivity to chlorine differs from one microbial group to another and, in some cases, within the life cycle of one species. Indicators and pathogens most commonly isolated from water (e.g., E. coli, Klebsiella, Salmonella, Shigella, and Pseudomonas) show similar resistance to chlorine. Salmonella species [See also Section B.1.a(i)] are not exceptionally resistant to chlorine and should be controlled effectively by proper application of disinfectants. The same holds true for Francisella tularensis (Gotovskaia and Mogaram, 1945) [See Section B.1.a(v)] and most of the other bacterial pathogens.

However, there are other microbes whose resistance to chlorine exceeds that of the coliform group; these include spores of clostridia and of aerobic bacteria, enteroviruses, yeasts, acid fast bacilli, and cysts of protozoan pathogens. It is well established that enteroviruses are more resistant than E. coli to chlorine (Butterfield, 1948; Engelbrecht, et al., 1978; Weidenkopf, 1958) [See Table E.5.a-3] although there are no data for the hepatitis A virus. Yet, even among the enteric viruses, there is variation in resistance to chlorine. When water of zero chlorine demand and 0.5 mg per l free residual chlorine was held at 2°C, the time needed to inactivate 25 human enterovirus types ranged from 2.7 min for reoviruses to > 120 min for coxsackievirus A (Liu, 1978). Grouped according to their resistance to chlorine, viruses compare with E. coli in the following order: poliovirus > coxsackievirus > coliphage MS<sub>2</sub> > E. coli. Moreover, viruses may be gradually selected for resistance to chlorine after repeated sublethal exposure (Bates, et al., 1977). In similar studies, Shaffer (1978) found poliovirus, all of serotype 1, to exhibit varying sensitivity to chlorine.

A review by Engelbrecht and Greening (1978) compared data which, although collected under different experimental conditions, nevertheless serve to indicate that Mycobacterium fortuitum, M. phlei, and Candida parapsilosis [See Sections A.2.a and C.2.f] are more resistant than poliovirus to chlorine.

Data on survival of Entamoeba histolytica [See Section B.1.c(i)] exposed to free chlorine, ammonia, and chloramines are summarized in Figures E.5.a-2 and 3. The parameter of cysticidal residual used in these calculations is defined as that concentration required to kill 99.999 percent of cysts. From the curve in Figure E.5.a-2, it is clear that ordinary

FIGURE E.5.a-2

TIME-CONCENTRATION RELATIONSHIP IN DESTRUCTION OF CYSTS OF ENTAMOEBEA HISTOLYTICA BY HOCl AT 3° AND 23° C

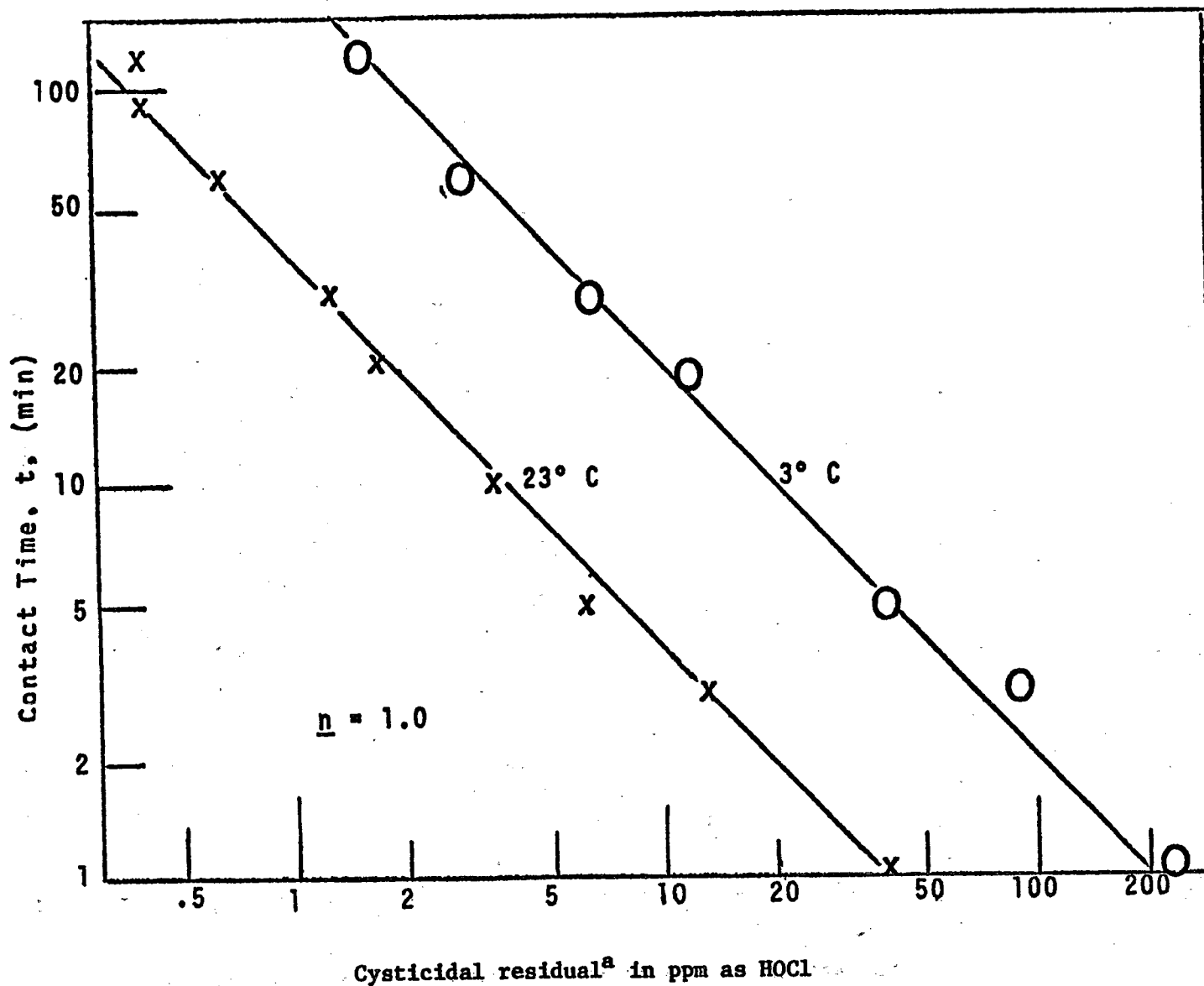

<sup>a</sup>Concentration required to kill 99.999 percent of cysts.

FIGURE E.5.a-3

EFFECT OF TEMPERATURE ON CYSTICIDAL EFFICIENCY  
OF  $\text{NH}_2\text{Cl}$  and  $\text{NHCl}_2$

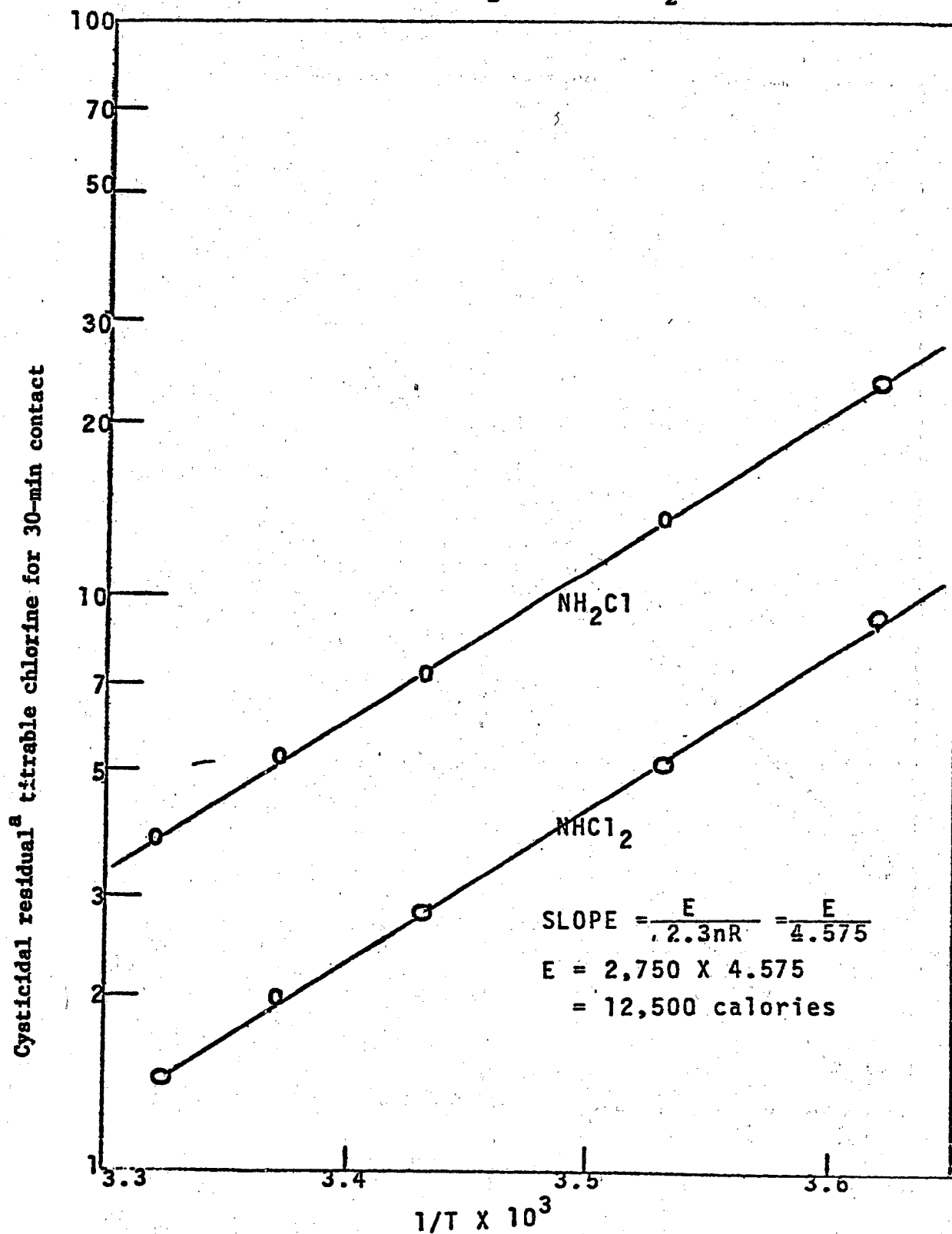

<sup>a</sup>Concentration required to kill 99.999 percent of cysts.

chlorination practiced in water treatment is inadequate to kill cysts (taking into account pH and temperature effects). Chlorine concentrations needed to kill E. histolytica cysts in clarified water in 20 to 30 min can exceed 9 ppm, depending on pH, temperature, and ammonia concentration. Likewise, Giardia lamblia cysts [See Section B.1.c(ii)] are not destroyed by chlorination at dosages and contact times commonly used in water treatment. Moreover, Acanthamoeba and Naegleria cysts [See Sections B.1.c (iii) and (iv)] are both highly resistant to chlorine (Dejonckheere and van de Voorde, 1976), which may account for their widespread presence in U.S. (and probably other) water supplies. Infective larvae of hookworms and threadworms [See Section B.1.c(v)] are more resistant to disinfection than enteric bacteria, viruses, or even protozoan cysts.

(v) The Action of Chlorine on Microorganisms. Chlorine acts on bacteria by changing membrane permeability, causing a loss of cellular material including potassium and UV-absorbing material (probably nucleic acids and protein). Also altered is the zeta potential of the membrane (Venkobachar, et al., 1977), whereby ozone acts upon those membrane-linked respiratory enzymes containing sulfhydryl groups (e.g., aldolase, triosephosphate-dihydrogenase, glutamate decarboxylase) (Green and Stumpf, 1946; Knox, et al., 1948). Finally, chlorine reacts with nucleic acids (Bocharov and Kulikovski, 1971; Fetner, 1962; Rosenkranz, 1978; Shih and Lederberg, 1976) of both bacteria and viruses.

Using coliphage f2, Dennis and coworkers (1979) demonstrated that chlorine reacted first with RNA (incorporation of chlorine being pH-dependent). In another study, chlorine was found to also react with the protein capsid of coliphage f2 (Olivieri, et al., 1975). In the case of enteric viruses, it probably is their lack of enzymes and other sensitive systems that accounts for their greater resistance to chlorine.

(Vi) Summary. It is certainly true that chlorine alone cannot produce safe drinking water. However, the chemistry and microbiology of chlorine disinfection of water have been studied for many years and have resulted in a rich base of scientific literature. Used appropriately, chlorine is known to be effective against a wide variety of undesirable or pathogenic organisms in water. Other disinfectants may be superior in certain specific applications, but chlorine

remains the unchallenged standard for many purposes in drinking water treatment and distribution.

b. Ozone Treatment. Ozone ( $O_3$ ), an allotropic form of oxygen, is a potent biocide used extensively throughout Europe in drinking water treatment. Schonbein coined the name ozone in 1839, from the Greek word ozein, to smell, which is appropriate because ozone was first recognized in 1783 by the Dutch physician Van Marum, on the basis of a peculiar odor given off by an electrical machine. However, it was not until 1865, that Soret demonstrated the existence of a triatomic molecule and in 1873, Fox described the bactericidal properties of ozone.

In 1976, 200 water treatment facilities in Europe disinfected with ozone, compared to 20 in Canada, and only three in the U.S. (International Ozone Institute, 1976). Ozone has received more attention in the U.S., though, as a disinfectant of urban wastewaters and is used for this purpose at ten U.S. facilities.

Ozone's disinfecting capability is at least equal to that of chlorine dioxide (Holluta and Unger, 1954) [See Section E.5.c] and is greater than that of chlorine (Fluegge, et al., 1978; Munger, et al., 1977; Traenhart and Kuwert, 1975) [See Section E.2], bromine, and iodine (Kruse, et al., 1970) [See Sections B.1.c(i) and E.5.d]. The powerful germicidal properties of this agent are due to its high oxidation-reduction (redox) potential that results from the different chemical forms of ozone formed in water, particularly the primary and secondary free radicals. It follows that, for all types of microorganisms, the specific coefficient of lethality, as defined by Morris (1967), is always higher for ozone than it is for free chlorine or chloramines.

(i) Factors Affecting the Disinfection Efficiency of Ozone. The efficiency with which ozone can be expected to disinfect water is influenced, as is true with other chemical oxidants, by: (1) the quality of the water to be treated; (2) the amount of disinfectant applied and the contact time; and (3) the types and densities of microorganisms in the water.

(i.1) Quality of the Water to be Treated. A discussion of water quality must address the parameters of pH,

temperature, suspended matter, and chemical composition. Ozone's bactericidal and virucidal capabilities are far less dependent on pH than are those of chlorine (Diaper, 1972; Kinman, 1975; Traenhart and Kuwert, 1975). Different authors have variously reported ozone to be effective as a disinfectant between pH 5.8 to 8 (Suchkov, 1964), pH 6 to 8 (Evison, 1977), and pH 5.6 to 9.8 (Farooq, et al., 1977a).

Part of the ozone decomposes into secondary oxidants in water at a rate that increases with higher pH's. At higher decomposition rates there is less ozone residual. This results in a reduced microbial inactivation rate for a given ozone dosage. The effect of pH seems to be entirely through its influence on the ozone residual, such that, if the ozone dose is adjusted to produce a standard residual, the microbial inactivation rate is the same at different pH's (Farooq, et al., 1977a).

Higher temperatures cause greater ozone inactivation of microorganisms, as predicted by the Van't Hoff-Arrhenius theory (Fair, et al., 1968), possibly due to the increased rate of disinfectant diffusion into microbial cells and greater reactivity with cellular substrates. However, the solubility of ozone in water decreases with increased temperatures and one might, therefore, expect the need for greater amounts of ozone with higher temperatures. Yet, between 6 and 30°C (Kinman, 1975), or 5 and 25°C (Evison, 1977), the inactivation rate of ozone remained nearly the same for colony counts and for phage 185. In fact, Farooq and co-workers (1977b) found that, for a given quantity of injected ozone and within a range of 9 to 37°C, an increase in temperature both enhanced inactivation and increased the residual ozone concentration.

Although some authors claim that turbidity has no effect on ozone disinfection (Cerkinsky and Trahtman, 1972; Gevaudan, et al., 1971), Block (1977) found that a population of poliōvirus 1, 90 percent of which was adsorbed to kaolin, was more difficult to inactivate with ozone when the turbidity reached 9 Jackson turbidity units (JTU).

Ozone, upon injection into water, may follow any (or a sequential combination) of four pathways: (1) no diffusion in the water; (2) diffusion and autocatalytic oxidation; (3) diffusion and immediate reaction with organic matter; or (4) diffusion and temporary maintenance (a few minutes) of an active residual. The oxidizing action of ozone is dissipated rapidly in the presence of organic matter, but a weak



microbial inactivation is obtained with no measurable residual of ozone (Block, 1977; Block, et al., 1977; Burleson, et al., 1975; Coin, et al., 1967; Farooq, 1976; Katzenelson, et al., 1974; Majumdar, et al., 1974; Mercado-Burgos, et al., 1975) [See Figure E.6-1, Zone 1]. According to Farooq and coworkers (1976), inactivation of microorganisms in the absence of residual ozone could be the result of collisions between microbes and ozone bubbles that are covered with a liquid film of high ozone content. The same authors found that the presence of ozone bubbles alone increased disinfection by 90 percent. Block (1977) showed that in the absence of residual ozone, inactivation was proportional to the ozone concentration in the gas bubbles.

Beyond a critical ozone dose injected at the breakpoint, a dissolved ozone residual is formed [See Figure E.5.b-1, Zone 2] which can be measured by conventional methods. Inactivation of microorganisms in Zone 2 is rapid and considerable, and is a function of the concentration of dissolved residual ozone and contact time (to be discussed later). Disinfection, being almost instantaneous once the ozone demand is satisfied, is reflected by a sharp drop in the survival curve, referred to as the all-or-nothing effect (Fetner and Ingols, 1956; Pavoni, et al., 1972; Tonelli and Ho, 1977). This effect is probably due to a sudden increase in the redox potential of the solution, causing immediate catalysis induced by the residual ozone present.

A similar discontinuity is not evident in the curve for organic matter [See Figure E.5.b-1], possibly because only minor changes occur in it (Block, et al., 1976), or because microorganisms comprise only a miniscule portion of the total organic matter that is measured in the system (Block, 1977). At the breakpoint, low concentrations of organic matter do not interfere with the inactivation of microorganisms by ozone unless the organism actually is imbedded within, and therefore physically protected by, the organic matter (Evison, 1977; Gevaudan, et al., 1971).

(i.2) Ozone Dosages and Contact Time. Inactivation of microorganisms occurs extremely rapidly once an ozone residual is present. Inactivation also relates directly to the redox potential, wherein ozone, with a redox of 350 mv (Fetner and Ingols, 1956) or 400 mv (Block, 1977; Hugues and Plissier, 1977), applied for 2 to 4 min has been demonstrated to inactivate > 99.9 percent of the microbial population. This compares quite favorably to chlorine, which

FIGURE E.5.b-1

DIAGRAMMATIC REPRESENTATION OF COMPLETED BREAKPOINT REACTION  
For OZONE

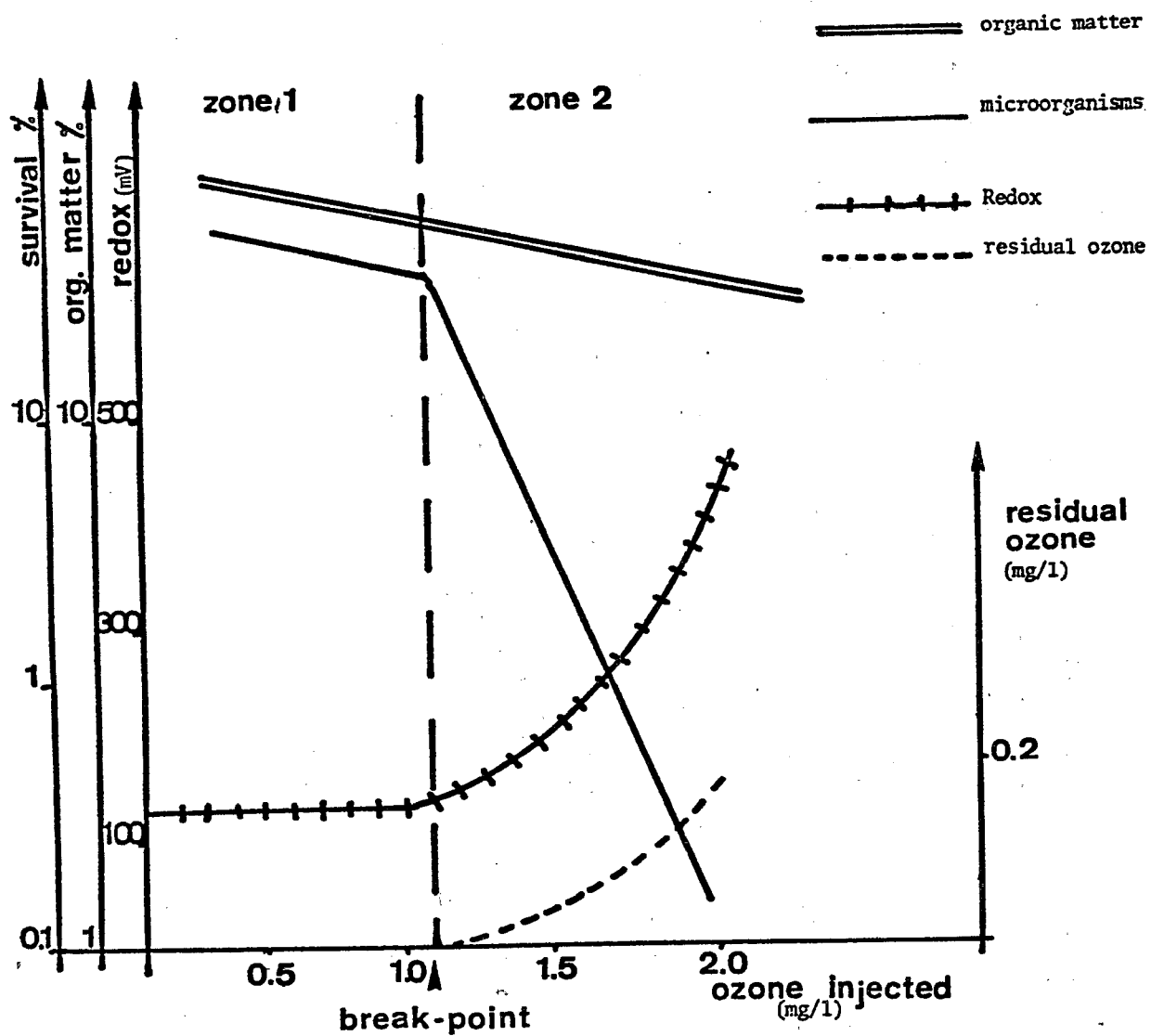

requires a redox of 500 mv and a contact time of 60 min for an equivalent inactivation (Lund, 1963).

Tables E.5.b-1 and 2 summarize data from various studies on inactivation of bacteria and viruses by ozone. There are a great many apparent discrepancies in these tables, which might at first glance be attributed to differences in experimental conditions. However, if one recalculates the results on the basis of the product of ozone concentration (in mg per l) and time (in sec) required to cause 99.9 percent inactivation of a microbial agent in water that is free of organic matter, one finds that the discrepancies are small. For example, this product is either 3.0 (Block, 1977; Burleson, et al., 1973) or 2.5 (Farooq, et al., 1976) for E. coli and either 1.8 (Evison, 1977) or 1.9 (Block, 1977) for poliovirus 1.

In every case, the ozone residual dissolved in water remained the one critical parameter of disinfection efficiency. Knowing this, water treatment authorities can ensure the elimination of both micropollutants and aggregated or adsorbed microorganisms simply by applying ozone dosages higher than those applied in the laboratory.

(i.3) Sensitivity of Microorganisms to Ozone. Different organisms exhibit different sensitivities to ozone and many authors have tried to use this observation as a basis for classifying groups of organisms. Although some generalities can be drawn from such an exercise -- for example, that poliovirus 1 is more resistant than E. coli to ozone (Block, 1977; Evison, 1977; Farooq, 1976; Katzenelson, et al., 1974), or that bacterial spores are highly resistant to ozone treatment (Broadwater, et al., 1973; Burleson, et al., 1976; Haufe and Sprockoff, 1973; Leiguarda, et al., 1949), ambiguities emerge under closer scrutiny. Contradictory results have been obtained by several authors studying the relative sensitivities of three poliovirus types (Coin, et al., 1964, 1967; Evison, 1977; Snyder and Chang, 1974).

Other factors are likely involved in influencing the sensitivity of organisms to ozone. These might include: different techniques for preparation of stock cultures, age differences of the cultures (Wuhrmann and Meyrath, 1955), and aggregation phenomena (demonstrated experimentally using ultrasonication to change the inactivation kinetics: Burleson and Pollard, 1976; Dahi, 1977; Katzenelson, et al., 1974). Furthermore, relative sensitivity to ozone

TABLE E.5.b-1

## SUMMARY OF DATA FROM STUDIES OF BACTERIAL INACTIVATION BY OZONE IN WATER

Water	Bacterium	Ozone (mg/l)		Contact Time (sec)	Inactivation (%)
		Injected	Residual		
Distilled water	<u>E. coli</u> <sup>a</sup>	- <sup>b</sup>	0 to 0.02	-	95 to 99.9
Distilled water	<u>E. coli</u> <sup>a</sup>	-	0.05 to 0.16	180	100
Distilled water	<u>E. coli</u> <sup>a</sup>	-	0.07	10	99.99
Distilled water	<u>E. coli</u> <sup>a</sup>	-	0.3	3	100
Deionized water	<u>E. coli</u> <sup>a</sup>	-	0.19	300	100
Pure water	<u>E. coli</u> <sup>a</sup>	-	0.01	60	99.99
Pure water	<u>S. faecalis</u> <sup>c</sup>	-	0.01	15	99.99
Tap water	<u>E. coli</u>	1.0	0.02	150	99.9
Tap water	<u>S. faecalis</u>	1.0	0.02	150	99.9
Tap water	<u>E. coli</u>	-	0.3	600	93
River water	<u>E. coli</u>	-	0.04	240	100
Phosphate buffer	<u>E. coli</u>	-	0.20	15	99.9
Phosphate buffer	<u>E. coli</u>	-	0.25	10	99.9
Phosphate buffer	<u>E. coli</u>	0.4 to 0.5	-	60	99.9

TABLE E.5.b-1 -- Continued

Water	Bacterium	Ozone (mg/l)		Contact Time (sec)	Inactivation (%)
		Injected	Residual		
Buffer	<u>E. coli</u>	0.006	-	420	99
Buffer	<u>E. coli</u>	-	0.05	12	99
Wastewater	<u>E. coli</u>	-	0.01	75	99.9
Wastewater	<u>E. coli</u>	-	0.30	15	99.9
-	<u>E. coli</u>	-	0.009	40	99.9
-	<u>E. coli</u>	-	0.01	90	99.99
-	<u>E. coli</u>	-	0.1	5	99.9
-	<u>E. coli</u> and <u>S. faecalis</u>	-	0.13 to 0.2	60	99.9

<sup>a</sup>Escherichia coli.

<sup>b</sup>Data not reported by author.

<sup>c</sup>Streptococcus faecalis.

TABLE E.5.b-2

## SUMMARY OF DATA FROM STUDIES OF VIRAL INACTIVATION BY OZONE IN WATER

Water	Virus Tested	Ozone (mg/l)		Contact Time (sec)	Inactivation (%)
		Injected	Residual		
Distilled water	Poliovirus 1	1	0.1	60	99.99
Distilled water	Poliovirus 3	- <sup>a</sup>	0.22	180	100
Distilled water	Poliovirus	1.27	0.23	150	100
Distilled water	Poliovirus 1	1.27	0.23	150	100
Distilled water	Poliovirus 1	1	0.25	240	100
Distilled water	Poliovirus 1	-	0.3	10	99.5
Distilled water	Poliovirus 1,2,3	-	0.4	180 to 240	99.99
Distilled water	Poliovirus 1	-	1.0	120	99.99
Distilled water	Coliphage T <sub>2</sub>	-	0.09	10	99.5
Distilled water	Coliphage T <sub>1</sub>	-	0.5 to 0.55	300	100
Distilled water	Coliphage f <sub>2</sub>	-	-	15	100
Distilled water	Coliphages T <sub>1</sub> , T <sub>2</sub> , and T <sub>3</sub>	2	-	120	100
Tap water	Poliovirus 1	1.0	0.01	150	99.9
Tap water	Poliovirus	-	0.05	-	99.9

TABLE E.5.b-2 -- Continued

Water	Virus Tested	Ozone (mg/l)		Contact Time (sec)	Inactivation (%)
		Injected	Residual		
Surface water	Poliovirus 3	-	0.22	180	100
Surface water	Coliphage T <sub>1</sub>	-	0.5 to 0.55	300	100
Dnieper river water	Poliovirus 3 & coxsackievirus B	4 to 5	0.2	900	99.7 to 99.9
Seine river water	Poliovirus 1,2,3	-	0.4	180 to 240	99.99
Phosphate buffer	Poliovirus 1	-	0.25	20	99
Buffer	Poliovirus 1	-	0.03	60	99.9
Buffer	Coliphage	-	0.18	240	99.95
Wastewater	Poliovirus	1.38	0.20	150	100
Wastewater	Poliovirus 1	-	0.30	20	99
Wastewater	Coliphage f <sub>2</sub>	15	0.015	300	100
-	Poliovirus (purified)	-	0.045 to 0.45	120	100
-	Poliovirus	-	0.15	-	100
-	Poliovirus 2 and coxsackievirus B3	1.13	0.28	60	100

TABLE E.5.b-2 -- Continued

Water	Virus Tested	Ozone (mg/l)		Contact Time (sec)	Inactivation (%)
		Injected	Residual		
-	Poliovirus	-	0.45	120	100
-	Poliovirus	-	0.5	240	100
-	Poliovirus 3	0.7 to 1.2	-	10	99.99
-	Enterovirus	-	0.2	-	99.9

<sup>a</sup>Data not reported by author.



varies with contact time and ozone concentration. That is, at disinfection levels necessary to obtain a 99 percent inactivation, poliovirus 1 was more sensitive than coliforms; yet, these two entities showed the same sensitivity when a 99.99 percent inactivation was sought (Ghan, et al., 1976).

The initial density of a microbial population does not appear to affect inactivation kinetics as long as increased numbers do not increase the ozone demand in the water (Block, 1977). On the other hand, the presence of organic matter does interfere with disinfection efficiency (Farooq, 1976).

(ii) Action of Ozone on Microorganisms. Ozone inactivation of bacteria can be described as an oxidation reaction (Bringmann, 1954), both the reaction and the inactivation being rapid. The ozone acts on at least three sites on the bacterium: the cell wall, the cytoplasmic membrane, and the nuclear apparatus.

Ozone acts on the cell wall, causing bacterial cell lysis and death which adds soluble COD to the water (Rosen, et al., 1974). Cell lysis, however, probably is not the primary means of inactivation, but a consequence of either high ozone levels (at the gas-liquid interface) or prolonged ozonation (Perrich, 1976). The cytoplasmic membrane probably is affected first (Christensen and Giese, 1954) by reactions of ozone with glycoproteins, glycolipids, (Scott and Leshner, 1963; Smith and Bodkin, 1944), or the amino acids tryptophan (Goldstein and McDonagh, 1975) or cysteine (Mudd and Freeman, 1977). Bacterial death also may result from changes in permeability of the cytoplasmic membrane. Ozone disrupts bacterial respiration by reacting with the sulfhydryl groups of certain enzymes. Bacteria exposed to ozone were shown to lose their ability to degrade sugars and produce gases (Vronchinskii, 1963). Ozone reacts with glucose-6-phosphate dehydrogenase as well as with other enzyme systems (Chang, 1971b).

In addition, ozone can act on the nuclear material and provoke mutations. Christensen and Giese (1954) and Scott and Leshner (1963) demonstrated that ozone affects both purines and pyrimidines. More recently, Prat and coworkers (1968) showed that pyrimidine bases of nucleic acids in E. coli undergo modifications when the bacteria are treated with ozone (thymine being more sensitive than cytosine or uracil). Sublethal exposure to ozone can cause nucleic acid mutations similar to those caused by x-rays, without impairing growth and division of the cell (Hamelin and Chung, 1974, 1975).

(iii) Summary. Ozone is effective against both bacteria and viruses in water. As a principal disinfectant (and disregarding cost), it appears to be faster and more effective than chlorine as well as less influenced by water quality; its only relative shortcoming is that active ozone residuals cannot be maintained in water for significant periods of time [See also Section F.2.a and Project Area IIA]. Ozone also has been used, with relative success, prior to slow sand filtration [See Section E.3] to render compounds more biodegradable.

c. Chlorine Dioxide. The history of chlorine dioxide, its physical and chemical properties and reactions, methods for generation and measurement, and its uses in water treatment have been reviewed in several recent publications (Gall, 1978; Miller, et al., 1978; Rosenblatt, 1975; Sussman and Rauh, 1978; White, 1972). Chlorine dioxide has been used primarily as an oxidant in industrial processes for bleaching of pulpwood, textiles, flour, fats, oils, and waxes. Its use in the treatment of drinking water has been extremely limited, however, especially in the U.S.; and when used at all, chlorine dioxide has been applied mainly to improve the organoleptic properties of the water rather than to disinfect. Recently, chlorine dioxide has been viewed with increased interest as a possible alternative to disinfection with chlorine, against which arguments have been raised concerning its capacity to generate toxic and carcinogenic compounds [See Section E.5.a].

(i) Bactericidal Efficiency. Of results reported in earlier studies on the bactericidal efficiency of chlorine dioxide, only some have been upheld by later work.

Ridenour and coworkers (1949) showed that chlorine dioxide was more effective than chlorine for inactivating endospores of Bacillus subtilis, B. megaterium, and B. mesentericus. Berndt and Linneweh (1969) also reported that chlorine dioxide was a more efficient sporicide than chlorine. In addition, Ridenour and Ingols (1947), and Ridenour and Armbruster (1949) found chlorine dioxide to be an effective bactericide against indicators (Escherichia coli, Enterobacter aerogenes), enteric pathogens (Salmonella typhi, S. paratyphi B, and Shigella dysenteriae) [See Sections B.1.a(i) and (ii)], and other pathogens (Staphylococcus aureus, Pseudomonas aeruginosa) [See Sections B.1.a(ix) and F.2 to 3]. Their results indicated that the disinfection

efficiency of chlorine dioxide increased at higher pH's and that it was a more efficient bactericide at pH 9.5 than chlorine. The work of Trakhtman (1946), and Bedulevich and coworkers (1953) also indicated that the bactericidal effectiveness of chlorine dioxide was equal to or greater than that of chlorine against E. coli, S. typhi, and S. paratyphi. However, their results indicated that its effectiveness decreased rather than increased under alkaline conditions. Early studies by McCarthy (1944; 1945) indicated that chlorine dioxide was an effective bactericide in water low in organic matter content, but was less effective when organic matter concentrations were higher.

White (1972) reviewed several of these early studies and pointed out that the lack of methods for preparing pure chlorine dioxide free of residual chlorine, and the lack of analytical procedures for measuring it in the presence of other oxychloro chemical species, would have tended to produce errors in which analytic results showed mistakenly high chlorine dioxide levels. Hence, the disinfection efficiency of chlorine dioxide would, in fact, be higher than had appeared in these earlier tests.

Later, Granstrom and Lee (1958) developed improved methods for preparing and analyzing chlorine dioxide. Benarde and colleagues (1965), using these improved techniques, compared the bactericidal efficiency of chlorine and chlorine dioxide at pH 6.5 and 8.5 in a disinfectant demand-free buffered system. At pH 6.5, chlorine was slightly more effective than chlorine dioxide when compared on the basis of weight. However, at pH 8.5, chlorine dioxide was even more effective than it was at pH 6.5, whereas chlorine efficiency declined at the higher pH, reflecting a decrease in HOCl (the more effective disinfecting species) and an increase in OCl<sup>-</sup> (the weaker disinfecting species) at higher pH's. Cronier and colleagues (1978) also showed that within a pH range of 4.5 to 9.0, the bactericidal efficiency of chlorine dioxide increased as pH increased.

In other studies, Benarde and coworkers (1965) used sewage effluent to demonstrate that chlorine dioxide was a more efficient disinfectant than chlorine in the presence of high levels of organic material. An initial dose of 2 mg per l of chlorine dioxide obtained > 99 percent reduction of E. coli in sewage after 5 min of exposure, whereas 5 mg per l of chlorine destroyed only 90 percent of E. coli after the same length of exposure. Moffa and coworkers (1975) reported similar results when they compared the bactericidal

action of chlorine and chlorine dioxide applied as disinfectant to combined sewer overflows.

(ii) Virucidal Efficiency. Ridenour and Ingols (1946) reported that chlorine dioxide was as effective as chlorine against a mouse-adapted strain of poliovirus 1. Hettche and Schulz-Ehlbeck (1953) reported that 0.08 mg per l of chlorine dioxide was as virucidal for poliovirus as was 0.15 mg per l of ozone [See Section E.5.b] or 0.25 mg per l of free chlorine. An increase in pH from 5.7 to 8.5 enhanced inactivation of poliovirus 3 (Warriner, 1967); and chlorine dioxide inactivated poliovirus (Mahoney) 4.6 times faster at pH 9.0 than at pH 7.0 (Cronier, et al., 1978). Chlorine dioxide at pH 7.0 and free residual chlorine at pH 6.0 showed approximately equivalent virucidal efficiencies. As with chlorine [See Section E.2]; however, enteric viruses were found more resistant than E. coli to chlorine dioxide (reviewed by Allen, 1979) [See also Sections B.1.b and C.2.b].

(iii) Cysticidal Efficiency. No reports appear to be available on the efficiency of chlorine dioxide for disinfecting protozoan cysts, notably those of Entamoeba histolytica and Giardia lamblia [See Section B.1.c].

(iv) Mechanism of Action. Ingols and Ridenour (1948) suggested that, following adsorption onto and penetration of the cell wall, chlorine dioxide exerted its bactericidal action by reacting with intracellular enzymes containing sulfhydryl groups. Benarde and coworkers (1967) showed that the incorporation of  $C^{14}$ -labelled amino acids [See also Section C.4.a] stopped within a few seconds after exposure of E. coli to chlorine dioxide, indicating interference with protein synthesis. Olivieri (1968) showed that the inhibition of protein synthesis in bacteria exposed to chlorine dioxide was dose-dependent. Examination of cell extracts showed the site of action to be localized in the portion of the cell containing enzymes. The ability of ribosomes to function in protein synthesis was not affected. Studies on the effects of chlorine dioxide on bacterial and viral nucleic acids apparently have not been performed.

(v) Use of Chlorine Dioxide in Water Treatment. Miller and coworkers (1978) reported that chlorine dioxide

is used for some purpose in at least 607 water treatment plants throughout the world. Of these, 495 are in Europe, 84 are in the U.S., and ten are in Canada. In the U.S., chlorine dioxide is used mainly for purposes other than disinfection (i.e., taste, odor, and color control; manganese and iron removal). It is used as the sole disinfectant at only one treatment plant in the U.S. In Europe, chlorine dioxide is used frequently for disinfection, but nearly always in combination with some other disinfectant, usually ozone or chlorine.

(vi) **Conclusions.** The available evidence indicates that chlorine dioxide is effective for disinfection against bacteria and viruses. When compared to chlorine on the basis of weight, in mg per l, its disinfection capability is equivalent to free residual chlorine at pH 6 to 7 and is appreciably more efficient than free residual chlorine at higher pH's, which are encountered more commonly in actual water treatment plant operations. An additional advantage is that it does not react with ammonia, as does free residual chlorine, to form chloramines, which are less effective as germicides. Organic compounds normally present in water exhibit a high chlorine demand with free residual chlorine, but appear to be less reactive with chlorine dioxide. Thus, biocidal capability is maintained more effectively with chlorine dioxide than with chlorine.

The bactericidal and virucidal effectiveness of chlorine dioxide is well established; research is needed to determine its ability to inactivate the cysts of waterborne pathogenic protozoa, especially those of E. histolytica and G. lamblia. Additional information on the mode and site of its disinfectant activity also is needed. Other research needs not related directly to disinfection include: (1) developing improved methods for measurement, particularly in the presence of other disinfectants; and (2) evaluating health effects of its major end products, chlorite and chlorate, and of compounds formed by its reactions with other organic compounds in water.

d. **Iodine.** Historically, iodine has been used primarily in homes and hospitals as an antiseptic for skin surfaces, wounds, surgical instruments, etc. Iodine has been studied as a disinfectant for water for nearly 30 years.

The chemistry of iodine, methods for measurement, and use in water treatment were reviewed by White (1972). In

the pH range 5 to 8, iodine dissolved in water is present predominantly as diatomic iodine ( $I_2$ ) and hypiodous acid (HIO). Both of these chemical species are considered to be effective biocides, although more recent evidence suggests that the hydrated iodine cation ( $H_2OI^+$ ) may be the active species (Cramer, et al., 1976). At higher pH levels, the ineffective biocidal species hypiodite ( $IO^-$ ) and iodate ( $IO_3^-$ ) are formed. White (1972) indicated that formation of these inefficient disinfecting species would not be a problem below pH 8.4. The relative amounts of titrable iodine existing as  $I_2$  and HIO in aqueous solutions depends on the pH, iodine concentration, and to a lesser extent, temperature. Although it is true that elemental iodine and hypiodous acid are the two most powerful disinfecting species of iodine, their relative efficiency varies considerably depending on the microorganism exposed. Elemental iodine was more effective than hypiodous acid for inactivation of Bacillus metrens spores and Entamoeba histolytica cysts [See Section B.1.c], whereas hypiodous acid was more effective than elemental iodine for inactivation of enteroviruses and Escherichia coli (White, 1972). Although there is a considerable body of literature on the biocidal efficiency of iodine, comparison of the results of different investigations is virtually impossible because of the lack of consistency in experimental conditions such as temperature and pH, methods for measuring and reporting free iodine, and microorganisms used.

(i) Bactericidal Efficiency. Chambers and coworkers (1952) studied the bactericidal efficiency of iodine under closely controlled conditions of temperature, pH, free iodine concentration, and exposure time. Bacterial species studied were Aerobacter (now Enterobacter) aerogenes, Salmonella paratyphi, S. schottmuelleri, S. typhimurium, S. flexneri, Shigella dysenteriae, S. sonnei, and Streptococcus faecalis, as well as two strains of E. coli and three strains of S. typhosa. The results were reported as that free iodine concentration required to kill all bacteria exposed ( $\approx 10^3$  per ml) in 1 min. Under the most favorable conditions (pH 6.5, 20 to 26°C), 0.6 mg per l of free residual iodine killed all species tested. Under the most adverse conditions (pH 9.15, 2 to 5°C), 4.3 mg per l of free residual iodine was required.

Chang and Morris (1953) evaluated elemental iodine as an emergency disinfectant for drinking water. Because they

were interested in practical applications, they used tap water rather than well-defined, iodine-demand-free buffer systems. They determined the effects of color, turbidity, and nitrogenous material, as well as temperature and pH, on the bactericidal efficiency of iodine. At 25°C and pH 8.1 to 8.5, iodine concentrations of 2 to 5 mg per l reduced E. coli by approximately 6 logs in 10 min. They found in further studies that S. typhosa, S. schottmuelleri, Shigella dysenteriae, and mixed coliforms present in sewage were about as iodine-sensitive as E. coli, whereas Vibrio cholerae was more sensitive. The bactericidal efficiency of iodine was approximately the same over a pH range of 4.5 to 8.1. Low levels of ammonia and urea nitrogen (5 mg per l), and turbidity from clays (50 to 500 mg per l) had no measurable effect on disinfection efficiency, but high concentrations of fine loess (165 to 245 mg per l) interfered with bactericidal action. Berg (1966) indicated that the bactericidal efficiency of  $I_2$  was about one-fifth that of hypochlorous acid, but about ten times that of the hypochlorite ion.

(ii) Virucidal Efficiency. Chang and Morris (1953) studied the virucidal efficiency of aqueous iodine using mouse-adapted poliovirus 1. Because of technical problems, they were able to conclude only that iodine did have virucidal properties and that it was effective against viruses at the level needed for inactivation of amebic cysts. Chang (1958) reported on the virucidal efficiency of several chemical species of iodine for coxsackievirus B1: HOI was somewhat more virucidal than  $I_2$ . At 25°C, approximately 60 min was required to reduce coxsackievirus B1 by 5 logs when exposed to 1 mg per l of residual  $I_2$ . Triiodide and iodite ions were non-virucidal.

Clarke and coworkers (1964) found that 99 percent of an E. coli strain was killed by 1 mg per l of  $I_2$  in only 1 min at 25°C, whereas 18 h were required to inactivate coxsackievirus A9 under similar conditions. Of five viruses tested, coxsackievirus A9 was the most resistant to elemental iodine; and the time required to produce equivalent inactivation of two different enteroviruses was 200 times longer for elemental iodine than for hypochlorous acid. Zoeteman (1972) interpreted these data as indicating that, as a virucide, iodine was much less efficient than free chlorine and slightly more effective than combined chlorine. However, Mahnel (1977) tested iodine and free residual chlorine against poliovirus 1, enteric cytopathic bovine orphan virus, reovirus 1, canine hepatitis virus, pseudorabies virus, vaccinia virus, Newcastle disease virus, and a bovine parvovirus. He found

that concentrations of iodine needed to inactivate all viruses at a pH between 5 and 8.5 were equal to or less than the concentrations of free residual chlorine needed for equivalent inactivation.

(iii) Cysticidal Efficiency. Much of the research on the cysticidal effects of iodine resulted from a military need for emergency disinfection of small water supplies. Amebic dysentery was endemic in many areas of military operation, and cysts of Entamoeba histolytica [See Section B.1.c] had been shown to be highly resistant to chlorine; disinfection studies directed at inactivation of this organism led to the development of the globaline tablet, presently used by the U.S. Armed Forces for disinfection of individual drinking water supplies (Chang, 1958; Chang and Morris, 1953; and Morris, et al., 1953).  $I_2$  was two to three times as cysticidal as HOI, so the globaline tablet was designed to release 8 mg per l of free iodine, which was sufficient to inactivate 5 logs of E. histolytica cysts in 10 min at pH  $\leq$  8.0.

Stringer and coworkers (1975) essentially confirmed the earlier results indicating that  $I_2$  was the more active cysticidal species and that cyst inactivation rates were very slow at higher pH's. However, they found hypochlorous acid to be a more effective cysticide than  $I_2$ .

Information on Giardia lamblia cyst inactivation by iodine is not available.

(iv) Mechanism of Action. Historically, iodine has been considered to act like chlorine as a general cellular poison exerting its lethal effect by oxidation of sulfhydryl groups on enzymes or proteins (Dunn, 1952). Brandrick and coworkers (1967) showed that radioactive elemental iodine reacted with E. coli and Staphylococcus aureus by both oxidation-reduction and halogenation. Brammer (1963), Hsu (1964), and Hsu and coworkers (1966) showed that viral RNA from viruses and transforming DNA from bacteria inactivated by iodine remained active, indicating that the biocidal activity resulted from reactions with protein rather than nucleic acid components. Berg and coworkers (1964) reported that the kinetics of coxsackievirus A9 inactivation were consistent with a "single hit" hypothesis and inferred that inactivation resulted from reaction with a single iodine molecule. The failure of iodine to inactivate viral nucleic



acids has been cause for concern, although evidence of an actual hazard for man posed by these entities has not been provided.

(v) Use in Water Treatment. Although much of the research on the biocidal properties of iodine has been directed toward its potential use for drinking water disinfection, actual field studies have been very limited. Black and coworkers (1965) found iodine was an effective disinfectant in the water supplies at three Florida correctional institutions serving a population of about 700 persons. Although coliform bacteria were usually present in the untreated water, fewer than 1 percent of the samples treated with iodine were positive for coliforms. They concluded that 1 mg per l of iodine rendered the water supply safe under a variety of conditions including pH levels up to 7.5.

(vi) Conclusions. The available evidence indicates that iodine is an effective disinfectant for water. Iodine is probably somewhat less efficient than hypochlorous acid, but maintains peak disinfectant activity even in mildly alkaline water and is less subject to demand because it is less chemically reactive. The main deterrents to its use appear to be high cost and concern for yet-to-be-demonstrated adverse effects of long-term exposure to iodine on thyroid function (Kinman, *et al.*, 1970). Although interest in iodine as a disinfectant has been restimulated as a result of the concern about chloroform and other trihalomethanes formed by water chlorination, studies on the formation of iodine-containing trihalomethanes apparently have not been published. Needed research on iodine as a disinfectant for drinking water principally concerns health effects and chemistry, rather than microbiology.

## 6. Summary

Pathogenic microorganisms are often present in waters that are contaminated with domestic sewage. It is essential to consumer safety that waterworks produce safe drinking water even from potentially contaminated raw water despite the demand for ever-increasing quantities. In this connection, the different treatment processes applied in the preparation of drinking water have been evaluated from the standpoint of their capacities to remove microorganisms. The most generally applied treatment processes, which have

been discussed in the previous sections, include: storage in reservoirs, coagulation, rapid and slow sand filtration, dune infiltration and underground storage, activated carbon treatment, chlorination, and ozonation..

These processes can be evaluated on the basis of their abilities to remove bacterial indicators of fecal contamination (viz., thermo-tolerant coliforms) and pathogenic agents that are more resistant than indicator bacteria (viz., polioviruses of the enterovirus group). A rough estimate of the removal percentage has been made for each treatment process, based on the data presented in Topic E and the cited literature [See Table E.6-1]; these must be considered only as guideline approximations.

The tabulations show that, depending on the quality of the raw water, a combination of different treatment processes can produce hygienically good finished water. A proper combination of treatments will result in a high capacity to remove bacteria and viruses. It should be noted that the removal or inactivation estimates for viruses are based on the polioviruses, which are only three of the more than 100 types of enteric viruses that may be present in water. However, in practice, no outbreak of enteric virus disease has ever been attributed to properly treated water.

Less information is available concerning parasitic cysts and metazoan parasites. Most of these organisms are supposed to be removed by sand filtration processes, but in some cases, sand filters did not effectively remove Schistosoma cercariae from the water. Thirty to 90 percent of the parasitic cysts can be removed by coagulation. Disinfection with chlorine can be accomplished only by doses much higher than those used in the preparation of drinking water. The evaluation of the treatment processes with respect to removal of these organisms is difficult because insufficient data are available. In practice, however, outbreaks of parasitic diseases have not been reported in connection with drinking water that has been adequately treated; coagulation and filtration steps are essential.

The data presented here and the experience of waterworks over many years lead to the conclusion that a proper choice of different combinations of treatment processes, depending on the raw water quality, will result in the production of finished drinking water that meets the microbiological standards. Further research is needed concerning the behavior of parasitic cysts, metazoan parasites, and

TABLE E.6-1

ESTIMATION OF THE PERCENTAGE OF MICROORGANISMS  
REMOVED BY VARIOUS WATER TREATMENT PROCESSES

Treatment Process	Residual Disinfectant (mg/)	Contact Time (min)	Removal Percentage	
			Fecal Coliform Bacteria	Poliovirus
Open reservoir storage <sup>1</sup>			95 - 99.9	99 - 99.9
Coagulation			50 - 97	70 - 99.99
Sand filtration (a) Rapid			10 - 50	0 - 50
(b) Slow			70 - 99	96 - 99.99
Dune infiltration and underground storage			99.99	99.99
Activated carbon			10 - 50	<sup>2</sup>
Chlorination (a) Breakpoint	2 - 3	1 - 2	99.99	99.9
(b) Post	0.1 - 0.5	15 - 30	99.9	99
Ozonization	0.3 - 0.4	2 - 4	99.999	99.99

<sup>1</sup> Average detention time 30-75 days.

<sup>2</sup> - not considered.

viruses, and to evaluate the threat to human health engendered by the presence of extremely low levels of pathogens in drinking water.

#### 7. Recommendations

1. The variety and degree of treatment used in preparing drinking water should be determined by the quality of the raw water.
2. Where the source is variable in quantity or quality, reservoir storage may be used to buffer some of the fluctuations.
3. Disinfection is essential in the production of safe drinking water.
4. Physical (e.g., rapid sand filtration) and biological (e.g., slow sand filtration) processes should be employed more extensively prior to terminal disinfection so as to increase disinfection efficiency and reduce the risk of formation of toxic substances.

## F. DISTRIBUTION SYSTEMS

With the application of standard water treatment techniques, water suppliers usually have no difficulty in producing potable water supplies of a quality that will meet the WHO European Standards for Drinking Water. During distribution through the supplier's network and within the consumer's plumbing system, this water is exposed to a variety of hazards.

A water supply distribution system is not a totally sealed entity, so the possibility of contamination from external sources must be considered. It is easy for consumers to make connections into the system and either accidentally or unknowingly introduce hazardous situations. Equipment and fittings of numerous types are necessary for the effective use of a water supply, and the design of these must be considered in relation to potential hazard.

The multitude of possible materials that could be used for the construction of pipelines and joints, all the water utilities' apparatus, and all the consumers' fittings is increasing at a rapid rate. The possible effects of all these materials on the quality of the water need consideration.

Some of the problems that have occurred from time to time in distribution systems have been public health problems; more commonly, they lead to complaints of taste, odor, color, or turbidity resulting from microbiological growth which have no public health significance, but which result in water quality that does not conform to national or international standards. This section examines some of these problems and ways of overcoming them.

## 1. Service Reservoirs

Service reservoirs are an essential part of any water supply distribution system, but they are frequently the weakest link in the system and are subject to several hazards. Reservoirs of this nature are known by different names in different countries, but the term is used here to include any treated water storage facility imposed between the water treatment works and the consumer. They may be underground concrete or brick structures, elevated tanks or towers, or possibly even open reservoirs suitably protected.

a. Direct Contamination from Sewage. The siting of sewers and service reservoirs in relation to each other is an essential feature of engineering design. Reservoirs should be on high ground so that surface water drains away from them and all sewers should be at a lower level. If a reservoir is on a slope, construction of buildings on higher land, with its attendant sewage and drainage hazards, should be avoided. Where there is any possible risk of leakage from local sewers, these should be laid with special precautions, such as in cast iron or encased in concrete. Risks from storm overflow should be avoided.

b. Contamination of Open Service Reservoirs. Once water has been treated, it should be fully protected and not see the light of day until it reaches the consumer's tap. This implies that all service reservoirs, tanks, and water towers should be covered, although there are known to be many open service reservoirs still in use in several developed countries.

The first and most obvious source of contamination of open reservoirs is from birds, including all kinds of water fowl, especially gulls. There have been several studies of pollution from gulls in different parts of the world, all of which have shown that a high proportion of these birds are carriers of salmonellae, especially in the more highly developed areas where they are in closer association with man (Jones, et al., 1978; Luttman, 1967; Metropolitan Water Board Report, 1966 and 1970a).

Elevated tanks and water towers with roofs also often provide attractive nesting sites for birds of all kinds, so that access to roof spaces must be adequately protected from small birds by netting which must always be kept in good

repair. Ventilating shafts of covered reservoirs must be similarly protected.

Flying insects can also be a nuisance and these can be excluded by covering the bird netting with fly screens. If only one ventilating shaft is installed, in a building at the side of a reservoir, the screening required will be small in area and more readily maintained.

Many waters exposed to daylight can also support algal growth of one sort or another; problems can occur where they have not been encountered before, due to the increasing need in many developed countries to utilize lowland, nutrient-rich rivers as sources of water supply. The algae can be controlled only by excluding daylight with adequate roofing.

c. Contamination from Leakage. A very common cause of bacterial contamination of service reservoirs is rain water penetrating through leaks in the roof. This is more common in older, brick-roofed reservoirs than in modern reinforced concrete structures. Leakage is enhanced by the penetration of plant roots and for this reason trees should not be planted on or alongside service reservoirs.

Contamination is frequently worse after heavy rain following a dry spell. A similar quantity of rain on an already saturated soil does not produce the same effect. This is probably due in the one case to penetration of polluted water through cracks in the dry soil and in the other case to the moist soil acting as a bacterial filter.

Contamination of this type frequently includes Escherichia coli or thermo-tolerant coliforms as well as other coliforms, presumably derived from birds, other wild animals, or domestic pets. The extent to which this type of contamination is detected will depend, considerably, on the method of sampling and the rate of water turnover in the reservoir. If sampling is carried out only once a week and the rate of turnover is high, the pollution resulting from one heavy thunderstorm can be gone before it is detected. Furthermore, as the contamination is from above, the highest concentration of polluting organisms is found near the surface and may be undetectable at the bottom drawoff point. Dip samples taken at the surface can, therefore, give results totally different from those of samples taken from the outlet main. Where this problem occurs, samples should be taken more frequently and at different points or depths in the reservoir.

Pollution of this nature can only be prevented by major repairs to the roof, either by complete reconstruction or by applying a waterproof coating, covering, or membrane which should extend down the walls below normal water level. In some cases, where minimal numbers of coliforms persist over a long period of time or occur relatively frequently during the year, long-term major repair or reconstruction programs may be necessary. The degree of risk involved must then be assessed in relation to priorities for capital expenditures.

d. Growth in Bottom Deposits. Because service reservoirs contain relatively still water, any suspended matter has an opportunity to settle as a sludge on the bottom. This suspended matter may be derived directly from inadequately treated water, due either to incomplete removal of silt, to filtration problems during algal blooms in the raw or stored water, or to post-precipitation of aluminum hydroxide. It may be generated in the trunk mains to the reservoir by the rusting or corrosion of the iron or steel mains or from wastes produced by small animals, such as Gammarus and Asellus, in the mains. It may also be produced by the precipitation of calcium carbonate, due to the loss of carbon dioxide, from high bicarbonate waters in the reservoir itself. Small animals may also live in this sludge and further modify its properties. Easily recognizable constituents of these sludges include calcite crystals, rust particles, amorphous siliceous material, Asellus fecal pellets, and organic debris.

Studies of these sludges have shown that they contain an abundant microbial flora which is quite different from that of the overlying water. Coliform organisms and E. coli are quite common in these sludges, even where they have never been found in routine examinations of the overlying water. Clostridium perfringens is also common, as are various fungi adapted to an aquatic environment. Some species of actinomycetes may be abundant, depending on the nature of the sludge, the water, and the water temperature. Protozoa usually are also abundant (Metropolitan Water Board Report, 1970b and 1973a).

Although these sludges seem to provide an environment for the development of particular ecological communities, the bacteria so produced do not seem to migrate in significant numbers to the overlying water. It is possible that certain by-products of microbial metabolism, notably



the odoriferous substances produced by fungi, could diffuse into the overlying water to cause a deterioration in quality, especially in taste.

The engineering design of reservoirs should be such that the water circulates along the floor and prevents static conditions that lead to accumulation of sludge, but this is not easy to arrange. Alternatively, the bottom layer should be left undisturbed, but cleaned out periodically when the reservoir is drained. This usually needs to be done at intervals of ten years or less.

## 2. Aftergrowth

Current methods of drinking water treatment in developed countries normally achieve a satisfactory bacterial quality in the water leaving the works and entering the distribution system. However, under some circumstances, growth of bacteria can occur in the distribution system after the water has left the works and this is usually referred to as aftergrowth.

a. Influence of Nature of Raw Water and Methods of Treatment on Aftergrowth. In order to grow, most common bacteria require the basic minerals that all living organisms require and a source of organic carbon. There are very few raw source waters used for public water supplies that do not contain adequate minerals in solution for the growth of a variety of bacteria, although different waters may favor different species according to their mineral composition. However, source waters differ widely in their content of organic carbon and, hence, in their ability to support microbial growth. Many underground waters are very low in organic matter and unable to support significant bacterial growth even though they may be quite rich in minerals [see Section A.1.].

Surface-derived waters, on the other hand, are relatively rich in organic matter and can support significant microbial growth; this microbial growth is an essential factor in the self-purification of rivers [see Section A.2.]. If this organic matter is not removed during treatment, it remains available and can support microbial growth thereafter, provided that conditions are otherwise suitable for growth.

The major part of the organic matter in natural waters consists of humic compounds that are relatively resistant

to biodegradation and only slowly utilized for bacterial growth, mainly by specialized groups of bacteria. The by-products of the initial breakdown are then used by other bacteria.

The more readily biodegradable carbohydrates, proteins, and protein breakdown products are less abundant in water, but when present, can support growth of numerous bacteria. The various water treatment processes will remove a proportion of this organic matter. Alum coagulation [see Section E.2] processes bring about the inclusion of humic substances in the alum floc. Slow sand filtration provides suitable [see Section E.3] conditions for bacterial growth and biodegradation of organic matter; that which is not readily biodegradable will not easily support microbial after treatment.

These treatment processes are almost invariably followed by an oxidation process, usually chlorination [see Section E.5.a] and sometimes ozonation [see Section E.5.b.]. During this oxidation process, which is primarily for disinfection, any remaining organic compounds which may be relatively resistant to biodegradation are liable to become partially oxidized to intermediate products that are more readily usable as bacterial nutrients and may thus, be a potential stimulus to aftergrowth.

Ozone, in particular, has often been claimed to have this effect. One of the major advantages of ozone treatment is that it oxidizes the humic compounds, which are yellow-brown in color, and thus, produces a more attractive looking water. This effect, coupled with the instability of ozone and the inability to maintain a residual in the distribution system, enables aftergrowth to occur. It has been shown, however, that chlorination can give rise to a similar aftergrowth if no residual is maintained (Metropolitan Water Board Report, 1973b).

Whether the basic disinfection process is chlorination or ozonation, aftergrowth of this nature can be limited by maintaining a suitable chlorine residual in the distribution system. In some countries and some areas, however, consumers object to the taste of chlorine. Complete prevention of aftergrowth requires a substantial and often unacceptable chlorine residual unless, as a minimum, a rigid line flushing program and treatment to minimize pipe corrosion are also practiced. Attempts to resolve this problem with chlorination alone are totally inadequate to prevent growth on some materials which have a chlorine demand, or in deposits of organic substances, particularly in protected

situations such as pipe joints, where chlorine cannot penetrate effectively and where the organic material present may bind the chlorine. Beulow and Walton (1971) reported that an increase from 0.2 to 1.5 mg of chlorine per liter was necessary to improve the coliform quality of water in a distribution system. Reduction in colony counts could be expected to require at least as great an increase in chlorine level. Lee (1971) showed under experimental conditions that, in the presence of nutrients, the same bacterial growth was obtained with 0.5 mg per l of chlorine (80 percent as free chlorine), as with no chlorine at all. Under the same conditions, 1 mg per l suppressed the growth of bacteria.

It has also been suggested, however, that if ozonation precedes a biological treatment process such as slow sand filtration, the bacteria will utilize the partially oxidized organic matter in the filter, producing a further improvement in the water quality and preventing aftergrowth in the distribution system. Chlorination before distribution would still be necessary. This principle has been applied in the Netherlands, where ozonation is followed by filtration to enable the aftergrowth, and the biodegradation associated with it, to occur in the filter instead of in the distribution system.

The bacteria that cause aftergrowth are usually those which prefer lower temperatures. This is reflected in the difference between bacterial counts using the two standard methods of bacterial colony counting employed in the water industry, namely, with incubation at 20 to 22°C and at 35 to 37°C. Aftergrowth is much more evident with incubation at 20 to 22°C and extension of incubation to seven days produces even greater differences. In lowland river-derived waters which receive treated sewage effluent, it is not unusual for colony counts (at 20 to 22°C) that are less than 100 per ml in water leaving the treatment works, to increase to over 10,000 per ml in a distribution system where only a low chlorine residual is maintained. These increases are directly related to temperature and time, being greater in warm weather and where the water has remained for long periods in service reservoirs. The draft EEC Directive relating to the Quality of Water for Human Consumption recommends some very low colony count guide levels that appear to have been formulated without regard for the problems of aftergrowth in the distribution system. In certain areas, some drastic changes would be needed to achieve these levels.

The bacteria that predominate in aftergrowth are not easy to characterize, for they are difficult to maintain in pure culture. Furthermore, determination of their biochemical properties often results in a classification of bacteria into groups that are not taxonomically precise. However, a major part of the colony count is usually assignable to the rather ill-defined Flavobacterium group. Pseudomonas, Aeromonas, Arthrobacter, Caulobacter, Cytophaga, and actinomycetes also form a small part of the population (Van der Kooij and Zoeteman, 1978).

The bacteria from lowland, surface-derived water that form colonies at 37°C are usually survivors of treatment, consisting largely of the chlorine-resistant spores of the aerobic sporeforming bacilli.

A technique for determining the concentration of growth stimulating organic compounds in water, in order to be able to quantify the aftergrowth potential of drinking water and to measure the effect of different water treatment techniques on these compounds, has been developed in the Netherlands at Keuringsinstituut voor Waterleidingartikelen (KIWA). Maximum colony counts of pure bacterial cultures developing in water samples were expressed in terms of the concentration of assimilable organic carbon (Van der Kooij and Zoeteman, 1978).

By using a medium containing citrate as the sole carbon source, Van der Kooij (1977) also showed that treated water, before entering the distribution system, contained a small percentage (0.1 to 1 percent) of citrate-utilizing bacteria, mainly Pseudomonas and some Aeromonas, but that tap water contained a higher percentage (1 to 10 percent and sometimes more). It is suggested, therefore, that these organisms can be used to give information on the efficiency of substrate removal by water treatment.

b. Accumulation of Organic Débris in Dead Ends and Other Protected Areas. The causes and effects of accumulation of sludges in service reservoirs are described in Section 1.d. Similar accumulations of debris occur in the distribution system wherever there is little or no flow of water, such as in dead ends or in any disused apparatus that has not been disconnected. The bacteria and fungi that grow in these situations, and their by-products, are continually seeded into the water that flows past the dead end, causing a deterioration in bacteriological and other quality characteristics, especially taste and odor..

A similar effect occurs, even in the absence of dead ends, where a district is supplied from two sources that are fed into different ends of a system. At some intermediate points where the pressures balance, there will be little or no flow in the main, and a similar situation will develop. In addition to the "dead end" effect, this situation contains the added hazard that changes in the supply, caused either by repair work or the introduction of new treatment works or extensions to existing works or mains, may alter the pressure balance. The areas of little or no flow will then shift and the accumulations of debris will become stirred up, resulting in turbid or colored water.

These problems can be overcome by designing distribution systems to avoid dead ends and by determining the sections where little or no flow occurs, then ensuring that adequate flow does occur at sufficiently frequent intervals to keep them clean by means of valves that control the direction and rate of flow. Where dead ends already exist, these must be adequately flushed through hydrants situated at their extremities. Furthermore, adequate monitoring of the water quality in the distribution system should include regular sampling from such dead ends, for they are likely to contain the worst quality water. Most developed countries have regulations, codes of practice, or make recommendations about frequency of sampling in the distribution system, and sampling points are defined in a variety of ways. All of the matters discussed in Topic F should influence the choice of sites and the frequency of sampling.

c. Interrelationships Between Organic Matter, Bacterial Growth, and Animals in the Distribution System. The problems of animals in the distribution system are not relevant to a report of microbiology, except insofar as the two topics are interrelated. Animals will only become a nuisance in distribution systems when they can multiply to relatively large numbers. To do this, they require a source of food which must usually be organic particulate matter, either living or dead; unlike bacteria, they cannot live directly on organic matter in solution. However, if the organic matter in solution supports growth of bacteria and fungi, these organisms can be used as food by protozoa, and many animals can feed on bacteria, fungi, and protozoa. Therefore, conditions that discourage the aftergrowth of bacteria should discourage the growth of animals.

Animals are very rarely a nuisance in distribution systems supplied with slow sand filtered water. The paucity

of animals has been attributed to the greater efficiency of slow sand filters in removing the animals' ova from the water. However, the true explanation may be quite different. Nearly all distribution systems contain a small nucleus of animals, but they are generally unable to grow in slow sand filtered water, probably because the bacteria on which they feed have grown and remained in the filter bed, so that the food chain leading to growth of animals in the distribution system cannot get started.

d. Chemical Changes in Distribution Systems. Changes in the physical and chemical characteristics of water during distribution may be chemically induced, such as the leaching of heavy metals and other materials from pipes, pipe joints, or pipe linings. They may be, on the other hand, micro-biologically induced, such as the production of moldy, musty, or earthy tastes resulting from the by-products of the growth of fungi or actinomycetes on susceptible organic materials in the distribution system. More commonly, however, there may be a complete interaction between micro-biologically induced changes and chemical reactions.

(i) Leaching of Heavy Metals. The problems associated with leaching of lead from lead piping are well known. There is now some concern over the possibility of leaching of lead, and to a lesser extent of arsenic and cadmium, from copper alloys containing lead and from solders and galvanizing. The copper alloys are used to overcome dezincification corrosion problems with brass. The leaching of lead from solder seems to be closely associated with the nature of the flux used. Arsenic is a common ingredient, at very low concentrations, in brass and cadmium and may be present as an impurity in the zinc used for galvanizing. Although these subjects are being investigated in various laboratories, little published information is yet available. The use of lead and tin compounds as catalysts in production of some plastic pipes is controlled by national and international standards. All these possibilities should be borne in mind when investigating trace heavy metal problems.

(ii) Precipitation and Depositions. The information in this and the following paragraphs (iii), (iv), (v), and (vi) is derived mainly from two reviews by the Water Research

Association in the U.K. (Ainsworth, Ridgway, and Gwilliam, 1978). Deficiencies in treatment are probably the major cause of dirty water. High levels of residual coagulant, together with the materials that it is intended to remove, namely, particulate matter, algae, and organic matter, will cause such problems; silica and manganese may also contribute. Gradual reductions in their concentrations through a supply indicate that these substances are settling out in the distribution system. Subsequent disturbance of these loose deposits is a common cause of objectionably dirty water.

Deposits formed by precipitation can also contain appreciable amounts of lead, nickel, and sometimes zinc and cadmium derived from waters with heavy metal concentrations well within the WHO recommended limits. These metals are probably being concentrated in the precipitates by chelation with organic matter and/or adsorption to hydrous iron and manganese oxides. Adsorption increases with pH and is reversible, so that pH changes could desorb heavy metals from precipitated organic complexes.

(iii) Changes in Source Water. Accumulated deposits of any kind are liable to undergo solution or disintegration if water from a supply with different chemical characteristics enters the distribution system. The growing tendency to obtain water from different catchments, and to alternate between different sources, has made this an increased possibility and probably the most important consideration when investigating the quality of alternative water sources for use in existing distribution systems. The most obvious result is a persistent dirty water problem, but the possible release of precipitated heavy metals must also be considered.

(iv) Total Organic Carbon. Even in a well-run treatment facility which relies on non-biological processes, soluble organic matter will remain in the treated water from a surface-derived supply at levels up to 5 mg per l of total organic carbon (TOC). A decrease in TOC, which will be greatest in lowland surface waters with initially high concentrations, may occur during distribution. Residual iron and aluminum, and iron produced by corrosion, will coagulate some organic material and some will interact with existing deposits and presumably be adsorbed. Further removal occurs by microbial metabolization. This leads to

decreases in dissolved oxygen, and more oxygen removal may result from corrosion.

(v) Microbially Induced Changes. These have been reviewed in detail by Hutchinson and Ridgway (1977). Some of these have been discussed in other sections of topic F. After some preliminary studies, these workers used a seven day, 22°C colony count in preference to a three day count, largely for the sake of convenience and greater flexibility in sampling days. In a general survey of distribution systems, they found, overall, that 40 percent of the samples had a count exceeding  $10^2$  per ml and 20 percent exceeded  $10^3$  per ml. The higher counts were commonly associated with dirty water problems. In lowland, surface-derived waters there was a marked trend for an increased incidence of other microorganisms, including fluorescent pseudomonads, anaerobic bacteria, sulphate-reducers, and, sometimes, the organisms found in the 37°C colony count. Microbial activity produced water quality changes such as depletion of dissolved oxygen, increases in total organic carbon, objectionable tastes and odors, greater corrosiveness, and the incidence of animals.

Local accumulation of biomass, whether in dead ends, at the bottom of service reservoirs, in pipe joints, or on unsuitable materials used in fittings, may result in anaerobic conditions. In these circumstances nitrate or sulphate-reducing bacteria and anaerobic sporeforming bacilli may grow (O'Connor, et al., 1975; Willis, 1957).

Nitrate-reducing bacteria are common in tap water, but they are unable to reduce nitrate at the dissolved oxygen concentrations normally found in tap water. Ammonia-oxidizing bacteria that are capable of producing nitrites may also be present. The reaction seems to be time-dependent under fast flow conditions. a decrease in nitrite concentration was also shown to occur, presumably due to production of nitrate by nitrite-oxidizing bacteria also present in the water; however, techniques for detecting these organisms are difficult (Victorin and Stenstrom, 1975).

Substances derived from otherwise harmless bacteria may cause pyrogenic reactions in a patient when drinking water containing high numbers of bacteria, due to after-growth, is used for some highly specialized purpose, such as in artificial kidney machines.



(vi) Corrosion. Corrosion products in iron mains are usually in the form of tubercles composed of a thin shell of the very hard mineral, magnetite ( $\text{Fe}_3\text{O}_4$ ). A mixture of hydrated ferrous oxides and iron sulfides is usually found under this shell, while the surface in contact with the water is a thin layer of goethite ( --  $\text{Fe}\cdot\text{O}\cdot\text{OH}$ ) in conjunction with substances adsorbed from the water, such as organics, silica, and manganese. The presence of sulfides indicates the involvement of sulfate-reducing bacteria in the corrosion process, although the extent of this is still open to conjecture [See Section G.4.b]. High corrosion rates are best diagnosed by inspecting pipe interiors and eliminating all other possible causes of discoloration before assuming that bacteria are responsible.

### 3. Growth on Materials

a. Ability of Various Microorganisms to Grow on Some Materials Used in Distribution and Plumbing Systems. It has been stated in Section 2.a that most common bacteria and fungi require mineral salts and organic carbon for their growth and that most water supplies contain adequate mineral salts in solution. In the construction of distribution systems, and in consumers' plumbing and fittings, many organic carbon materials are used, and the number and variety of these is rapidly increasing with the growth of the plastics and synthetic chemicals industries. It is, therefore, necessary to consider whether any of these materials are capable of supplying organic carbon compounds, that support microbial growth, to a sufficient extent to cause water quality problems, either directly by increasing bacterial numbers or indirectly from their by-products, inducing objectionable taste, odor, or even toxicity (Burman and Colbourne, 1979).

(i) Nature of Materials that Can Support Growth. The range of materials containing organic carbon compounds that have been employed in water supply systems includes natural and synthetic rubbers, paints and coatings, pump and valve gland packings, lubricants, sealants, jointing compounds, and soldering fluxes. They also include a wide variety of plastics such as polyethylene, polypropylene, polyvinylchloride (PVC), polyamide (nylon), polytetrafluorethylene (PTFE), acrylonitrile - butadiene - styrene (ABS), glass fiber reinforced polyesters (GRP), acrylics, acetal copolymers, polycarbonates, silicones, polyurethanes, polysulfides,

and many others, all of which exist in a wide variety of modifications with different characteristics for different purposes; some traditional materials such as leather washers and jute or hemp yarn are also present.

Deterioration in bacteriological quality of tap water due to the growth of coliform organisms on vegetable tanned leather washers was first described by Houston (1916). The bacteriological problems caused by the use of jute yarn as a caulking material for lead run joints in water mains has been well documented (Windle Taylor, 1947). Any other natural, unmodified product of plant or animal origin in contact with water, including any cellulosic material, linseed oil and other vegetable or animal oils and greases, soaps, and shellac can be expected to support microbial growth. Many mineral oils, greases, and waxes can also support growth of a more limited range of microorganisms. Natural rubber is in a different category. Natural latex will support abundant growth of a variety of bacteria and fungi, but many compounded rubbers are much more resistant and do not support sufficient growth to have a significant effect on water quality. However, long-term resistance to biodeterioration is a different problem [See Section G.1].

With some notable exceptions, the basic high molecular weight polymers used in plastics manufacture do not support microbial growth. The exceptions are the soft polyurethanes and polysulfides both of which can support considerable microbial growth resulting in biodegradation of the product (Evans and Levisohn, 1968; Jones and Campion-Alsumard, 1970; Metropolitan Water Board Report, 1970c). However, nearly all plastics contain a variety of other low molecular weight carbon compounds essential for their manufacture or necessary to provide properties for particular uses. These include catalyzers, antioxidants, plasticizers, fillers, extenders, pigments, sizes, bonding agents, lubricants, mold release agents, etc. Excess monomer may still be present, due either to inadequate polymerization or to a deliberate excess. Overheating in molding a fitting can also result in partial degradation with formation of other low molecular weight compounds. In the production or use of some polymers, a volatile organic chemical may be formed that can support microbial growth and must evaporate by adequate curing if problems are to be avoided when in contact with water. The production of acetic anhydride in some silicone jointing compounds is a good example of this. The materials most likely to cause problems are the plasticizers, including phthalates and sebacates, oils and waxes, cellulosic fillers

such as wood-flour, or cotton fibers, excess monomer, especially styrene, and bonding agents incorporated with various fillers such as glass fiber or pigments.

Synthetic detergents that support microbial growth can also be present in some products, either as residues from precipitation of a polymer from an emulsion in a detergent, or from the washing of fibers used in packing materials.

(ii) Nature of Microorganisms that Can Grow. To maintain national and international standards for bacteriological quality of water at the consumer's tap, the water bacteriologist will be interested in any organisms which affect his standard quality tests. These will include coliform organisms and any of the bacteria which can produce colonies in the standard 37°C or 22°C colony counts. Many of the materials under discussion have been shown to support the growth of coliform organisms and mixtures of organisms capable of growth in the colony counts. Many of them can also support the growth of *Pseudomonas aeruginosa* and various fungi. Growth is often sufficiently abundant under test conditions to form slimes on the material or clumps or flakes of growth suspended in the water which are readily visible to the naked eye. These slimes, however, often consist of bacteria which do not grow readily in the standard colony counts. This is probably because the carbon compounds on which they are growing, and to which they have become adapted, are totally different from the carbon sources contained in the standard colony counting media. Numerous protozoa usually develop in these slimes, and nematodes may eventually grow there as well.

b. Problems that Can be Caused by Microbial Growth.

Apart from failure to reach bacteriological standards, when tested by standard national or international methods, there are a number of additional problems that can arise. These problems are all accentuated at warm temperatures and under conditions of little or no flow. In modern buildings, for aesthetic and architectural reasons, hot and cold water pipes and central heating pipes are often installed in common ducts, with the result that the cold water has the opportunity to become warmed. In business premises unoccupied on weekends, there is no flow of water, thus, cold water temperatures can exceed 30°C and allow fungi and bacteria to grow much faster. However, warm water alone will not support the growth of organisms as described here.

Vending machines for drinks are often installed at the end of long lengths of narrow piping through warm factories separate from the rest of the supply system so that the only flow of water is that required for the cups of tea, coffee, or soft drinks. Drinking water fountains are often installed in similar situations and frequently give rise to complaints. Unused apparatus is often disconnected and the branch pipe left attached where there is no flow. These should always be removed at the junction with the main pipe.

(i) Taste and Odor. The growth of fungi and possibly of actinomycetes on materials, especially in consumers' plumbing systems, gives rise to musty, moldy, or earthy tastes in the water. In the Metropolitan Water Division, Thames Water Authority, London, it has been found that approximately 50 percent of all complaints referred to the Laboratories are of bad taste. In approximately half of these, there has been a significant increase in fungi, sometimes in conjunction with high bacterial colony counts or with the presence of P. aeruginosa (Burman and Colbourne, 1976).

(ii) Visible Growth. Under test conditions, visible growth is frequently observed on materials. This usually becomes very bad before a consumer notices it. Clumps of fungal growth on plasticized PVC tubing in drink vending machines sometimes detach and are discharged into the drinks. Accumulations of slimes have also been observed in tanks and cisterns constructed of unsuitable materials. Plasticized PVC capillary tubing used to supply water to dentists' drills has become blocked with visible growths of fungi. The aerator or antispash devices, again usually of plasticized PVC, often fitted to kitchen taps, are a frequent cause of complaint in which slime growths can readily be observed.

(iii) Health Hazards. It has generally been assumed that although the by-products generated by bacteria and fungi growing in distribution and plumbing systems, can cause complaints of deterioration in quality, they do not constitute a health hazard. However, there are two possible health hazards which should be considered.

First, the significance of P. aeruginosa must be considered. This is an opportunist pathogen of eyes and ears and causes infection of wounds and burns. It is particularly undesirable in water supplies to hospital burn units

and to tonsillectomy wards (Lowbury, et al., 1970). P. aeruginosa contamination of ice served in drinks has been incriminated in serious post-operative infections in tonsillectomy patients (Newson, 1968). This organism may rapidly multiply at low temperature and is undesirable in cooling waters, particularly in dairies. By forming an enterotoxin, P. aeruginosa can give rise to severe diarrhea (Muller, 1974). There are currently no international standards for P. aeruginosa in drinking water, but they are under discussion in a number of countries. German drinking water legislation considers P. aeruginosa as a pathogen, and according to paragraph 1 of the German Drinking Water Ordinance (Aurand, et al., 1976), drinking water has to be free of pathogens. The absence of P. aeruginosa in swimming water will be regulated by a law, currently in preparation; a standard method for enumeration of P. aeruginosa is specified. Water leaving the treatment works is normally free from this organism, so its appearance at the consumer's tap is an indication of deterioration in water quality [See also Sections B.1.a(ix) and C.2.c].

Secondly, the significance of the growth of fungi must be considered with regard to the possible production of mycotoxins or of allergens. Active toxins (mycotoxins) have been associated with massive growths of fungi on food products and there is no evidence that growth of fungi in water cannot produce similar effects.

Exposure to fungal spores inhalation in various industries has given rise to respiratory allergies. A "bathing sickness" with fever and respiratory symptoms following the taking of hot baths, has been described in Sweden (Atterholm, et al., 1977). This has been shown to be produced merely by breathing the air above hot water, through volatile substances released from the water. It has been associated with water from two areas, one a filtered, surface-derived water and one an underground water. Although fungi produce volatile by-products readily detected by their odor, and released when water is heated, no abnormal counts of fungi or other microorganisms have been obtained from this water. However, similar reactions have resulted at sauna baths where abundant growth of fungi has occurred on the wood: precipitating antibodies against an antigen extracted from the fungal culture could be found in the patients' serum.

c. Methods of Testing Materials. The most reliable methods for testing the effects of materials on the quality

of the water with which they come into contact, are based on attempting to simulate the worst conditions under which the materials are likely to be used and to observe the effects on the test water. This is achieved by immersing the material in limited quantities of water kept at optimum temperature for microbial growth and changing the water at intervals of three or four days.

The overall methods used in the U.K. have been described by Burman and Colbourne (1979) and have been written as a British Standard draft which has been circulated for public comment. The microbiological methods have also been described by Burman and Colbourne (1977). The testing procedure involves consideration of three areas of study: (1) ability to support microbial growth; (2) effect on organoleptic and physical properties, especially taste, odor, color, and turbidity; and (3) toxicity, including toxic metals.

In the FRG, a test has been developed using a streptomycin-resistant mutant of P. fluorescens, P. cepacia, or P. putida in order to detect substances leached out of plastic materials that will be used in drinking water supply (Müller, et al., 1979). This is in preparation for a standard method and will be included in the FRG Standard Methods for water, sewage, and sludge examination (1979).

Although this section deals with testing of materials as it relates to microbiology, it would not be complete without references to the non-microbiological test procedures.

(i) Testing for Microbial Growth. As the test involves quantitative comparison with a control, it is necessary to standardize the test procedure as far as possible. Containers must be specially cleaned and the test carried out in premises free from atmospheric pollution by volatile organic solvents. A sample having a specified surface area is immersed in a standard volume of dechlorinated tap water and inoculated with a mixture of microorganisms by adding some polluted river water. This is incubated at 30°C and the water is changed twice weekly by replacement with dechlorinated tapwater only. This process continues for six to eight weeks. Negative controls containing glass samples, and positive controls containing paraffin wax, are similarly treated. Beginning the fourth week, the water is tested before it is discarded, for 37°C and 22°C colony counts, coliform organisms, P. aeruginosa, and fungi; the

sample and water are also observed for visible growth.

A material is considered to have passed the test if, in three consecutive water samples, coliforms and P. aeruginosa are not detected, the colony and fungal counts are less than ten times that of the glass control, and there is no readily visible growth on samples or in the surrounding water. This is a very brief summary of the procedure described by Burman and Colbourne (1977). It is claimed, after comparative trials in other laboratories, that the overall result of passing or failing the test is reproducible, although the group of organisms indicating failure may vary on different occasions and in different laboratories.

There are two obvious non-standard factors in this procedure: the mixture of organisms in the inoculum and the nature of the tap water. It has been shown that, provided the inoculum contains coliform organisms, P. aeruginosa, and a mixture of bacteria and fungi within fairly wide limits, its precise definition is not necessary. Soil extract, however, is not satisfactory. Distilled water is not an adequate replacement for tap water in the test, nor have satisfactory results been obtained with synthetic tap waters. Comparable results have been obtained with several surface-derived, underground, and soft upland waters.

A simple, quantitative alternative to this procedure has been developed; it replaces the 37° and 22°C colony counts, the fungal counts, and the assessment of visible growth by a more accurate and reproducible determination of total microbial activity based on the measurement of dissolved oxygen reduction (Colbourne and Brown, 1979). The test is carried out by a procedure similar to the growth test previously described, but in closed containers filled to the top with tap water saturated with air. This method still requires counting coliform organisms and P. aeruginosa, as these must be shown to be absent from 100 ml. Inequalities due to variability in the initial inoculum have been shown to disappear after the first three weeks of testing and no significant variation has been observed with several different types of tapwater (from surface-derived, underground, and soft upland sources); however, distilled water is unsuitable. This has become the recommended method of preference in the U.K.

(ii) Testing for Taste, Odor, Color, and Turbidity. These are usually determined by soaking the test material in chlorinated water and chlorine free water for 24 h at room temperature. If any change in taste, odor, color, or turbidity of the water is observed, the water is discarded and a further 24 h soaking is conducted and tested. This is continued up to a maximum of seven days as long as any change is observed. The tastes and odors observed in these relatively short-term tests are mainly those derived directly from the ingredients used in the materials and not secondary tastes resulting from bacterial or fungal growth. The ratio of sample size to volume of water must be standardized, and the intensity and nature of any persistent tastes or odors require interpretation, for many materials in common use will produce some persistent detectable change in taste or odor under these test conditions.

(iii) Toxicity. Determination of toxic hazards of new materials is much more difficult. There is no one standard test that can readily be used to assess even acute toxicity of leachates from materials. Carcinogenic and teratogenic properties are even more difficult, expensive, and time-consuming to determine.

Where all the ingredients of a material are known, useful information can be obtained from toxicology data banks, but this requires that manufacturers disclose the necessary details. Even where initial ingredients are known, all the subsequent reaction products may not be identified. The presence of toxic substances as impurities must also be considered.

Some acute toxicity test procedures, notably cytotoxicity tests, have, however, been used as screening tests and yielded occasional positive results with some materials. The leaching of toxic metals is more easily determined by the use of standard chemical analytical methods on leachates. Here again, it is necessary to standardize the aggressivity of the test water and to decide whether WHO standards should be applied to the water under test conditions or whether a dilution factor should be applied.

d. Standards and Regulations Relating to Materials in Contact With Water. In the U.K., the National Water Council tests water fittings to determine whether they conform to the water bylaws and publishes lists of approved fittings. The non-metallic materials used in fittings are tested for



their effect on water quality by the methods described in Section C and a list of approved materials is published. The Regional Water Authorities normally require all fittings and materials used on consumers' premises to be on these lists in order to ensure conformity with the bylaws.

Many British Standards, and some international standards, contain clauses specifying that materials used for fittings in contact with potable water shall be non-toxic; shall not produce any taste, odor, color, or turbidity in the water; and shall not support microbial growth. However, there is no British Standard for testing these properties. In response to a strong demand, a draft standard has been prepared and is currently under consideration by a British Standards Institution Committee.

In Germany, materials used in contact with drinking water are subject to regulations in the German Food Act and have to be tested by prescribed chemical and bacteriological procedures (Anon., 1974).

In the Netherlands, KIWA (Keurings Instituut voor Waterleiding-Artikelen, 1974) publishes a brochure presenting guidelines for the installation of domestic water supply systems to prevent many of the problems described in Topic F. These guidelines are currently being revised. KIWA (1977) also publishes a brochure (in Dutch) on "Protection against the penetration of foreign compounds in water distribution systems."

In the U.S., greater emphasis is given to regulating the durability, mechanical performance, and toxicological properties of a material, rather than to the effects of microbial growth. Durability, however, does imply resistance to biodeterioration.

e. Growth on Atmospheric Volatile Organic Chemicals. A rather special case of microorganism growth on materials in contact with water is that involving water exposed to air contaminated with volatile organic chemicals, the commonest of which is ethanol. This is a common problem in some industries, but it has also been reported in retail shops, business premises (especially hairdressers), and even in homes (Poynter and Mead, 1964).

Ethanol is the most common substrate because it is most widely used; but any volatile organic chemical, such as

methanol, acetone, acetic acids, styrene, benzene, petroleum, and paraffins can cause a problem. The nature of the mixture of organisms that will grow depends on the chemical nature and characteristics of the water. Mixtures of fungi and pseudomonads are common, including P. aeruginosa, and sometimes aerobic sporeforming bacilli are present.

The growth usually appears as a gelatinous slime, especially around the edges of water tanks, around float valves discharging into the water, or hanging from running or dripping taps. This gives the impression that the slime is in the water supply, whereas it does not form until the water is exposed to the contaminated atmosphere. These slimes often become quite massive and include numerous protozoa that feed on the bacteria, and eventually nematodes.

The problem has occurred in the alcohol-distilling and bottling industries, varnish and paint industries, in museums using alcohol for preservatives, in buildings under construction where adhesives containing volatile solvents are used for laying floor tiles, in premises of hairdressers using alcohol-based hair lacquers and in homes where hair lacquers are used in unventilated bathrooms, in the printing industry where solvents are used to clean type, in printing and duplicating departments in offices, in roof spaces following treatment of roof timbers with preservatives, in buildings where petroleum products are stored in drums, in rooms where glass reinforced polyester products containing excess styrene are stored, and in numerous similar situations.

The fittings usually involved are open tanks and float valves, dripping taps, tea boilers, vending machines for drinks, or any other exposed water surface. The problem can occur in rooms adjacent to where the offending chemical is used or produced, or even in rooms separated by a corridor. The problem is always worse with poor ventilation. It can only be overcome by a total exclusion of all exposed water surfaces from areas where volatile organic chemicals are likely to pollute the atmosphere, or by thorough ventilation after use where these chemicals are used only intermittently for short periods. It is important that buildings in which volatile organic chemicals are to be handled, be correctly designed in the first place, for it is much more expensive to correct this problem after it has occurred.

The phenomenon usually is only a nuisance, making the water unattractive for use, producing a taste or odor, or

making it unsuitable for the purpose required; but in the printing industry it has given rise to health hazards which are now recognized by H.M. Factory Inspectorate in the U.K. Industrial alcohol is used to clean type. Humidity in printing rooms is maintained, to prevent paper curling, by spraying water into the atmosphere, often from tanks located in the printing room and supplied via float valves. Under these conditions typical slimes develop in the tanks and the resultant bacteria and/or fungi are sprayed into the atmosphere where the staff are working. This produces an allergic respiratory response that may occur after about 10 min or may be delayed for 2 to 4 h; due to progressive sensitization, the intensity of the response increases with subsequent exposure. This could be an allergy specific to fungal spores, but it may be a response to the general effect of any foreign protein sprayed into the atmosphere, for the effect has been observed with slimes composed mainly of a single bacterial species without any fungi.

#### 4. Back-Siphonage and Cross-Connections

All water supply authorities in developed countries can quote examples of water supply contamination by back-siphonage due to inadequate plumbing, to equipment that pollutes the water during use, or from illegal cross-connections between different supplies. This type of pollution may introduce either chemical or microbiological hazards.

In that water quality in distribution systems is not being considered elsewhere in this report, it is appropriate to consider pollution of this type under Topic F, Distribution Systems.

a. Types of Back-Siphonage and Cross-Connections and Risks Involved. Back-siphonage may be defined as siphonage of liquid back against the direction of normal flow or pressure. Reduction in pressure can occur for various reasons within public water supply mains and in individual plumbing systems, to the extent that pressure falls below atmospheric pressure. If outlets are submerged below the level of a contaminated liquid, or even just above it, the liquid can be drawn back and pollute the supply, either to other premises or to other outlets in the same premises. Therefore, there are three simultaneous requirements for back-siphonage to occur: the water outlet must be submerged or just above the water surface; the controlling valve must

be open; and the pressure at the outlet must be below that of the free water level at the fitting.

Submerged outlets occur for a variety of reasons such as faulty design or wrong positioning of float valves; inadequate overflows; hoses and other attachments fitted to taps and showers discharging below sink, bath, or shower tray level so that they can be submerged in contaminated water; garden, agricultural, or industrial hoses discharging into tanks, ponds, or even buckets; or leakage between primary and secondary heating circuits. It must be recognized that pressure changes will occur in the supply and cannot be prevented. Sewer flushing systems used in some countries also impose a special risk under some circumstances.

In multi-story buildings, negative pressures can occur at higher levels due to discharges at lower levels. The use of booster pumps on consumers' premises can create special problems because of the reduced pressure that can arise on the suction side of the pumps.

The risks to which consumers are exposed, in the event of back-siphonage, will depend on the nature of the contaminant that is introduced and the frequency with which it is likely to occur. In addition to threats to health, such contamination may make water unacceptable for a variety of other reasons. The seriousness of risk can, therefore, be classified and the degree of protection against back-siphonage can be chosen according to the class of risk. The Water Research Centre in the U.K. carried out a survey of back-siphonage risks in homes and reached the conclusion that, although 85 percent of properties surveyed were at risk in terms of the requirements laid down in Model Water Bylaws, the probability of back-siphonage occurring was really very low (Gilfillan, 1971).

Cross-connections may be defined as connections between a piped public water supply and any other pipe carrying any other water or liquid that is not obtained solely from the public supply. They occur most frequently in industrial premises, where various process waters are used in complex plumbing systems, and they are especially significant where high pressure hydraulic mains are concerned. However, cross-connections can also occur in mains in the street and even in homes. Most of them occur outside of the control of the water authorities and are very difficult to prevent. There are many recorded instances of illness among factory staff, and sometimes neighboring consumers, due to cross-connections.

b. Regulations Concerning Back-Siphonage. Most developed countries have water bylaws, or regulations of some description, that are designed to prevent contamination, waste, or undue consumption of the public water supply. Many of these regulations are specifically designed to prevent back-siphonage. In order to make adequate regulations and to rationalize existing ones, it is necessary to have a thorough understanding of potential back-siphonage situations, the degree of risk involved, and methods of preventing their occurrence. To this end, the Department of the Environment in the U.K. appointed a committee which produced its "Report of the Committee on Back-Siphonage in Water Installations" in 1974 (Committee on Back-Siphonage in Water Installations, 1974).

However, regulations or bylaws are useless without adequate means of enforcement, including inspection of installations and schemes for the approval of fittings and materials, as discussed in Section 3.d of this report. Surveys have shown that there are large numbers of premises in which fittings do not comply with the provisions of existing regulations, that requirements for inspection following alteration or extension to existing plumbing are largely ignored, and that present frequency of inspection is inadequate to identify all the risks. It is recommended in the Report (1974), that an inspection force be staffed with one inspector per 25,000 people served. The number of violations that would be discovered by routine regular inspections would subject consumers to considerable expense if immediate corrections were required. It is, therefore, recommended that special attention be given to installations where large numbers of people congregate, to industrial premises, and to buildings with multiple occupancy.

c. Mechanical Devices and Hydraulic Safeguards. The prevention of back-siphonage is dependent on the incorporation of adequate hydraulic safeguards during installation and plumbing alterations and on the availability of reliable mechanical devices.

As a general principle, the degree of risk in each situation should be assessed and a mechanical device or hydraulic safeguard incorporated which is appropriate to the risk as well as to the reliability of the device. The cheapest, most effective, and most reliable means of protection is some form of air gap. Where the risk is greatest, such as where a pipe discharges into a container in which

the water becomes highly contaminated, an adequate air gap should be maintained between the pipe and the top of the container at which water overflows. Where the risk is less, the receiving container can be fitted with an overflow pipe; the effective air gap is the distance between the inlet pipe and the overflow pipe. This type of air gap works only if the overflow pipe does not become blocked. Stoppage of pumps downstream can also cause reverse flow.

The first type of air gap is used in certain industrial and research establishments; in baths, wash basins, and sinks; in drinking fountains; in tanks receiving water from other sources; on animal drinking troughs; and on overflow pipes discharging into a water closet or urinal. The second type of air gap is used for supplies to cold water cisterns and water closet flushing cisterns and is controlled by a float-operated valve.

A number of other devices are used in certain circumstances including complete separation of systems; for example, at mixing taps for hot and cold water; non-return and air break valves; air inlet valves at the fixed ends of hand-held flexible hoses; lay-flat hoses that collapse when sub-atmospheric pressure occurs, as commonly used for fire hoses; air venting devices on hot water systems; and pipe interrupters. International standardized test procedures are needed for assessing the adequacy of devices to prevent back-siphonage.

## 5. Main Laying and Repair

a. Codes of Practice to Prevent Contamination. Codes of practice can be formulated to minimize contamination of mains during installation and repair, and many codes exist for this purpose, but the extent to which these are enforced seems to vary considerably, both between countries and between different water authorities in the same country.

Ideally, protection from contamination should start in the pipe store by blocking off the ends of all pipes to prevent access of small animals and birds. These end seals should remain in position until the pipe is in the trench and about to be joined. Pipe trenches should be deep enough to leave a clear space below the pipe joint, so that dirt from the trench is not incorporated into the joint. Pipes should not be lowered into the trench and left standing in the dirt and water at the bottom of the trench; they should

be lowered directly into the jointing position and joined immediately. Surplus water should be continuously pumped from the trench, and any open pipe ends should be blocked off at the end of a day's work.

b. Problems with Jointing Materials. There are a number of jointing systems available, but these are mainly variations of four basic types: (1) lead caulking; (2) push fit with rubber rings; (3) bolted flanges; and (4) solvent cement.

The traditional "socket and spigot" joint for iron mains used a melted lead caulking method with a packing material, usually jute yarn, to prevent lead flowing into the pipe. The problems associated with bacterial contamination of jute yarn have been well documented (Mackenzie, et al., 1948). This material usually contains large numbers of coliform organisms and supports their growth, which made it difficult to obtain water free of coliform organisms from new mains. Chlorination was unable to solve this problem because the chlorine deviated before it could penetrate the packed yarn; furthermore, once the initial high dose of chlorine had dispersed, the remaining yarn could support further growth.

This problem was greatly reduced by using yarn treated with a mercurial biocide that sterilized the yarn and prevented subsequent growth, although later leaching would ultimately nullify this effect, and bacterial degradation of the yarn could be expected. The use of mercury-based biocides would not now be approved and in situations where lead caulked joints are still needed, a biologically inert yarn packing such as nylon or polypropylene usually is used. Whatever yarn is used, however, it should be kept in a closed container and cut to appropriate lengths with a clean tool. It should not be laid on the ground or in the trench, but inserted direct from the container into the joint.

The jointing system has now been very largely replaced by various push fit type joints using specially molded rubber rings. These newer types of joints are needed because non-metallic pipes, which cannot be caulked with lead, are increasingly in use. To assist the jointing process, a lubricant is essential on the rubber rings. Excess lubricant tends to get pushed into the socket, where it is protected from chlorination and flushing water. The

original lubricants were usually based on soft soap, which is capable of supporting abundant microbial growth. Soft soap is completely soluble in soft water and is, therefore, readily flushed out when the main is charged with water, except in the protected areas behind the rubber rings. However, hard water produces precipitates of calcium salts with this soap; these can remain on the joints, relatively immune to flushing out with water, and can also support microbial growth. A detailed study of this phenomenon was made by the U.K. Water Research Association and resulted in the introduction of an antibacterial lubricant, based on cetrimide, that is now marketed and widely used under the name Medlube. It is miscible with hard or soft water and cannot support microbial growth. The bacteriological quality of water from mains laid using this lubricant has shown considerable improvement over that obtained with the soft soap lubricant. Other newer lubricants are based on synthetic detergents that are capable of supporting microbial growth, but that are completely soluble in hard or soft water and are, therefore, flushed out more readily.

The rubber rings themselves should be made of a material that is unable to support microbial growth, as described in Section F.3. Many rubber formulations, both natural and synthetic, are also subject to long-term biodegradation brought about by species of *Nocardia*. The phenomenon was first described by Leeftang (1963) and subsequently investigated further in the U.K. by the Water Research Centre, the rubber manufacturers, and their trade associations. Difficulty is being experienced in formulating materials that will not support microbial growth, that will not biodegrade, and that have the required mechanical and physical properties for joint rings [see Section G.1.a]

c. Cleaning, Disinfection, and Sampling Procedures. Even where proper codes of practice are followed and there is good supervision, further precautions, to ensure adequate cleanliness of new mains, are necessary. Foam swabbing is effective for this purpose. Cylindrical polyurethane foam swabs, slightly larger in diameter than the main, are inserted at the beginning of new work. When the work is completed and all valves are open and the water supply is turned on, the water pressure pushes the swab forward while allowing some water to pass through. The flexibility of the swab enables it to negotiate bends and valves and pushes before it any dirt or debris, eventually discharging from



the open end. It is surprising how much dirt is removed by this process even in situations of supposedly clean main installation. It is important to have a strictly controlled system of issue and recovery of swabs to ensure that none are left in the main when it is put into supply, for there is nothing more certain to result in irate complaints than fragments of polyurethane foam discharging from consumers' taps. It should also be borne in mind that fragments of foam left in the system can support microbial growth, for polyurethanes can be biodegraded by various fungi.

It is not usual practice to carry out foam swabbing after repairs to old mains; inner surfaces of old mains may not be smooth and may cause excessive breaking up of the foam or even stop the swab completely. Also, it is often difficult to arrange a suitable discharge point in an existing main.

Before putting a new or repaired main into supply, it must be disinfected; most countries or water authorities have their own recommended procedures for this. Hypochlorite solutions using an injector or chlorine gas from a mobile chlorination unit may be used for this purpose. The section of main to be treated must be isolated by closing all valves; a dose of 20 mg per l Cl<sub>2</sub>, which must be achieved at all outlet points, is usually recommended. This should be left for 24 h in new mains, but in small repairs, 2 h is usually adequate. The main is then flushed with supply water until the chlorine residual at the discharge points is within acceptable limits, which may vary in different situations and in different countries, but may be as high as 2 mg per l.

After repair, disinfection, and flushing of small mains it is usual to put them straight back into supply. Samples are then taken to ensure that they meet the recommended bacteriological quality standards. With new mains, it is advisable to leave them full of water for 24 h after flushing before taking samples, to allow for possible aftergrowth in joints. They should not be put into service until satisfactory bacteriological results have been obtained. If this procedure is carried out a substantial amount of time in advance of their being required for supply, further bacteriological testing should be carried out before any consumers are connected.

d. Acceptable Standards. The WHO Standards for Drinking Water recommend that coliform organisms should be absent from 100 ml samples at all times and at all points in the distribution system. Various national standards recommend the action to be taken when this is not achieved. In new mains, this is sometimes very difficult to achieve, for the reasons given in Section F.3.b. Some water authorities, therefore, permit some relaxation under these circumstances. If the only detectable deterioration in bacterial quality is an increase in coliform organisms, without any thermo-tolerant coliforms, Escherichia coli, or fecal streptococci in a new main that is supplied with water free from any of these organisms, it must be concluded that the coliforms are multiplying on materials used in the construction of the main, either on the jointing materials, lubricants, or mains lining and as such would have no sanitary significance. Under these circumstances, some temporary relaxation of standards might be permitted, but the absence of fecal streptococci should be required.

The problems of aftergrowth, discussed in Section F.2, are liable to be accentuated in new mains and would make the application of the colony count guidelines in the draft EEC Directive relating to the Quality of Water for Human Consumption very difficult to achieve.

The significance of P. aeruginosa may also be considered in new mains. It is not a usual practice to look for this organism, but some studies have revealed its presence in a proportion of new mains. Its significance has been discussed in Section F.3.b(iii). It is desirable that international agreement should be reached regarding the status of this organism in water supplies, but its absence from 100 ml at all points in the distribution system would be much more difficult to achieve than the absence of coliform organisms.

## 6. Summary

a. Service Reservoirs. Service reservoirs, which are defined as any facilities for storage of treated water between the water treatment works and the consumer, are probably the weakest link in the distribution system, but are an essential part of it. Risks include direct contamination from sewage, which should be avoidable by careful

siting in relation to sewers. All such reservoirs should be completely covered to exclude daylight and all openings screened to prevent access by insects or birds, as the latter are a common cause of contamination. Rainwater penetrating through soil cover on roofs and through cracks in roofs is another common cause of contamination. This is worse after heavy rain following a dry spell, when cracks are present in the soil, and is accentuated by penetration of roots from trees planted too near the reservoir.

Any particulate matter present in the water is liable to settle in service reservoirs, and the accumulating sludge will support the growth of a variety of bacteria. The engineering design of reservoirs should be planned to avoid static conditions on the floor as much as possible, and periodic draining and cleaning is necessary at least once every ten years.

b. Aftergrowth. Untreated water sources contain variable amounts of organic matter which is removed or degraded to varying extents by different water treatment processes, including disinfection. This residual organic matter can support microbial growth that may appear as aftergrowth in the distribution system, especially when water temperatures are high. This can be limited, to some extent, by maintaining a high chlorine residual in the distribution system or by treating with ozone prior to a biological treatment process (e.g., slow sand filtration or carbon filter treatment).

Particulate matter may accumulate in dead ends and at any points where there is little or no flow between two or more interconnected sources of supply. The bacteria that grow, or tastes and odors derived from them, can be continually leaked into the water that flows past. Small animals, such as crustacea and oligochaetes, may also become a problem in areas where bacterial aftergrowth has occurred.

Changes in the chemical quality of water during distribution may be chemically induced, such as the leaching of metals from pipes or fittings or from the ingredients in some plastics. Deficiencies in treatment are a common cause of dirty water, for example when high levels of coagulant are in the system. Changes in source water, or mixing of water from sources with different chemical characteristics, can cause disintegration of accumulated deposits. Changes may also be microbiologically induced, such as the production of moldy

tastes due to the growth of fungi on organic materials. There are, as well, a number of common interactions between microbial changes and chemical reactions, some of which may result in the internal corrosion of iron and steel mains. Local accumulations of biomass can produce anaerobic conditions, resulting in growth of nitrate or sulfate-reducing bacteria and their chemical by-products.

c. Growth on Materials. Many bacteria and fungi can grow on a great variety of simple and complex organic compounds, either of natural or man-made origin. It is, therefore, important that materials used in distribution and plumbing systems should not contain enough of such organic compounds to cause either a direct microbial contamination or a deterioration in quality, such as moldy taste. In consequence, all new products intended for use in contact with treated water supplies should be tested, by a reliable method, for their ability to support microbial growth.

A special example of growth on materials is that associated with water exposed to volatile organic solvents, the commonest being ethanol. This gives rise to the growth of massive bacterial and fungal slimes wherever a free water surface is exposed to an atmosphere containing such vapors. These situations can occur in domestic as well as business and industrial premises.

d. Back-Siphonage and Cross-Connections. Reduction in pressure can occur in public water supply mains as well as in individual plumbing systems, and this is one of the conditions necessary for back-siphonage to occur, or for water to move against the normal direction of flow or pressure. Most water authorities have experienced problems from this cause, and many countries have bylaws or regulations designed to prevent its occurrence. Cross-connections, which may be defined as connections between a public water supply main and any other pipe, usually occur outside the control of water authorities. Recorded instances are not infrequent, sometimes with serious consequences.

e. Main Laying and Repair. Most countries have codes of practice to minimize contamination during main installation and repair. Jointing systems have been a common cause of problems, such as bacterial growth on jute yarn or

on the soft soap used for lubricating rubber ring joints. Nylon or polypropylene yarn should be used instead of jute and lubricants which will not support microbial growth should be used as well. Cleaning of new mains after construction may be facilitated by using foam swabs. Disinfection procedures are critical and codes of practice should be followed for satisfactory results. Sampling should be conducted after the main has been flushed and has stood full of water for 24 h, before being put into supply.

#### 7. Recommendations

1. Service reservoirs, which are defined as any treated water storage imposed between the water treatment works and the consumer, should be situated where risks from sewage contamination are minimal. Service reservoirs should be completely covered to exclude daylight and all openings screened to prevent access by insects or birds. They should be maintained in a good state of repair and drained periodically for cleaning.
2. Factors such as the presence of organic matter and the accumulation of debris in dead ends and at points where there is little or no water flow may lead to aftergrowth and possibly the presence of small animals in the distribution system. Dead ends should, therefore, be avoided in the design of a distribution system, and all disused apparatus should be disconnected at the junction with the main pipe. In areas where balanced pressures between different supply sources cause little or no flow, the mains should be flushed at intervals.
3. Distribution and plumbing systems should be constructed only of materials which will not support microbial growth. New products should be assessed by a reliable test procedure before they are used in contact with potable water.
4. It is essential that regulations to prevent back-siphonage and cross-connections be enforced.

5. Materials used in jointing systems and lubricants in mains should be restricted to those which have been tested by a reliable method and found not to support microbial growth. Adequate disinfection procedures after main installation and repair are essential and codes of practice should be strictly followed. Sampling of the water should take place after thorough flushing of the main.

### G. TECHNOLOGICAL ASPECTS

In highly industrialized countries, drinking water of good microbiological, chemical, and aesthetic qualities is routinely achieved with available treatment processes. Nevertheless, improved practices and equipment can exert their own influences by introducing man-made materials upon which microorganisms can become established. Reduced efficiency of operation, increased costs, and overstressed equipment are oftentimes the consequence. Such factors as degree of pipe bends and placement of joints, type and age of pipes, valves, and fittings, changes in pressure -- all combine with the constituents of a particular source water and occasionally give rise to complications within the system. Therefore, the growth of organisms within a distribution system, however harmless to man at the outset, may ultimately threaten the quality of the finished water through these indirect means.

Filamentous iron bacteria are largely responsible for corrosion of metal pipes and the concomitant deposition of insoluble ferric hydroxide along pipe walls and well screens. Such bacteria may also initiate pitting and tuberculation of pipes. The formation of pits and tubercles favors the survival of other organisms which can then attach to pipe walls and utilize dissolved substances present in the water. Furthermore, variations in hourly demand for water can bring about pressure changes sufficient to cause stripping of metabolic deposits and the delivery of dirty water.

Water mains are made of cast iron (both cement-lined and unlined), concrete, galvanized iron, polyvinyl chloride, and cement asbestos. Whether enzymatic digestion of these and other materials occurs or not is dependent upon individual ingredients used in the manufacture of various component parts, plus whatever organisms inhabit a particular water source.

Many additional devices are employed as aids to household practices; for example, to soften water for dishwashers,

washing machines, coffee percolators, steam irons, etc. Such auxiliary equipment, installed beyond a household tap or the water meter, may include ion exchangers which apply phosphate, polystyrene filters (to remove small particles or bacteria), and active carbon filters (to remove taste and odor). These devices may give rise to bacteriological problems, since the resins or the filters adsorb organic matter which is a good nutrient source for bacteria.

Besides imparting to the water objectionable odor, taste, frothing, color, and turbidity [See Section F.3.b] certain slime-producing bacteria can significantly disturb the hydrodynamics of turbulent flow through a pipe. A very slight irregularity in the thickness of a pipe wall, caused by growth of slimes, can interrupt the laminar stream flow enough to increase the friction factor, encumbering the energetics of the system with a greater resistance to flow.

Industrialized nations share a responsibility to understand and protect against indirect and long-term effects from new machinery and techniques, as they apply to old, familiar microbes. The added expense, loss of efficiency, and possible health hazards triggered by a plugged well screen, a constricted pipe, or an obstructed filter are some of the considerations with which this section is concerned.

## 1. Biodeterioration of Materials

a. Biodeterioration of Rubber Sealing Rings. Although it is over half a century ago that microorganisms were first claimed to be capable of destroying natural rubber (Sohngen and Fol, 1914), the first evidence that this occurred in the water industry was found in the Netherlands around 1950. Rook (1955) isolated pink colonies of Streptomyces sp., from rings from a water main, on pure latex agar. In pure culture, these organisms could bring about deterioration of thin strips of vulcanized rubber.

These investigations were continued by Leeftang and others on behalf of the Institute for Testing Waterworks Materials, the Netherlands (Keurings Instituut voor Waterleiding-Artikelen, 1961). Of 651 rings examined, 59 percent were deteriorated on the surface in contact with the potable water and only 15 percent showed deterioration on the soil side. The majority of joint rings showed a loss of rubber of less than 5 percent of the cross-sectional area. The age of the rings varied from two to 23 years, but age was not



the sole determinant of the degree of deterioration. In all, five or six instances of hydraulic failure were observed. It was concluded that the problem occurred when natural rubber rings were exposed to a flow of unchlorinated potable water and, in the Netherlands, this was particularly prevalent with dune waters. These conclusions have been reported together with the results of exposure trials of rubbers (Leeflang, 1963).

In 1963, reports of deterioration of rings manufactured to BS 2494 (British Standards Institute, 1955) were emanating from Australia through the Standards Association of Australia. The problem was associated, in particular, with rubbers from sewer lines which, after ten to twelve years of service showed losses of as much as 33 percent of the cross-sectional area. This was especially evident on the sewage side, above the liquid level.

Subsequently, Sphar (1966) sent questionnaires to manufacturers of pipe joint rings in the U.S. and he reported that before 1966, instances of microbiological deterioration were unknown. He cited a survey made by the American Concrete Pipe Association which reported no deterioration of rubber rings in concrete pressure pipelines carrying either chlorinated or unchlorinated water. Following laboratory trials of rubber rings manufactured in the U.S., Leeflang (1968) reported that all of the natural rubber and synthetic polyisoprene rubbers tested were attacked after two years' exposure in a test bath, whereas all the other synthetic rubbers were resistant.

Further studies in New Zealand by Kennet (1966) and Hills (1967) identified three types of "erosion": (1) attack spread around the ring which, it was claimed, occurs when the liquid levels are constantly varying from full to empty or when the pipe is fully charged with oxygenated water, as in a water main; (2) attack spread around an arc; this occurs when the liquid constantly varies between two levels (full and part full or empty and part full); and (3) attack at two points on opposite sides of the ring; this occurs when the liquid level is relatively static and little oxygen is present in the material passing through the pipe, as in a sewer. Many of the deteriorated pipe joint rings complied with the British Standards specification BS 2494 (British Standards Institute, 1955).

The New Zealand Department of Scientific and Industrial Research (1969) reported that 15 percent of the rings

examined showed serious deterioration and 40 percent slight deterioration on the sewage, or water, side. Examination of rubber rings after 25 years' service showed that, although 10 percent were free from excessive deterioration, others were degraded by as much as 50 percent. The condition was more evident in sewer pipes than in water lines.

Cundell and Mulcock (1973) continued this work and found, in a survey of 583 natural rubber jointing rings collected from domestic sewers in Christchurch, New Zealand, that 36 percent showed deterioration about the mean water line, 33 percent were deteriorated on the outside of the ring in contact with the soil, and 6 percent were deteriorated on both sides. Furthermore, three of the rings showed deterioration in excess of 50 percent of the cross-sectional area, with a further three having 10 to 50 percent deterioration. It was found to be difficult to predict the extent or future progression of attack. Signs of attack usually were not apparent until four years after installation, and after six years' exposure, more rings were attacked than unattacked. In that the majority of rings have only been used in Christchurch since about 1960, it is not possible to predict their probable life. All rings installed at this time in concrete sewers were found to be in advanced state of decay, suggesting that the phenomenon is progressive. However, it was claimed that no instances of hydraulic failure of pipelines had been reported in Christchurch to date. The authors remark that deterioration of natural rubber rings is not readily appreciated by those who lack first-hand experience with the problem. For this reason, it was claimed that the occurrence of the phenomenon may be more prevalent throughout the world than is generally believed by rubber and pipe manufacturers or pipe users.

In the U.K., the Malaysian Rubber Producers Research Association defended the use of natural rubber for pipe joint rings (Dickenson, 1965). It was suggested that the problem in the Netherlands might be related to the atypical potable water, derived from dunes, rich in dissolved minerals (notably phosphate), and distributed without chlorination. Furthermore, the conditions within the joint space of asbestos cement mains would lead to a high pH of the water in contact with the rings which, it was claimed, would favor the growth of Streptomyces sp., the organisms implicated in deterioration.

In 1969, Dickenson claimed that the oxidative attack on the rubber molecule by microorganisms was probably terminal

and, in view of the low incidence of terminal sites in fully vulcanized rubber, it was argued that low molecular weight fragments were necessarily produced by primary, non-biological degradation. In view of the extreme slowness of deterioration, it was suggested that the initial phase was one of nonspecific chemical oxidation; in support of this, it was claimed that chemical analysis of deteriorated rubbers had revealed a notable absence of persistent antioxidant, especially in the water environment. Other components of natural rubber might be subject to microbiological attack that could result in deterioration. These could include plasticizers and antiozonants, especially paraffin wax.

Further work in the U.K., undertaken by the Water Research Center (WRC), has concentrated on three aspects of the problem: (1) the bacteria involved in biodeterioration; (2) the incidence of deterioration in rubber rings recovered after service in potable water pipelines; and (3) the effect of rubber formulation on the rate of deterioration. WRC studies have confirmed many previous findings. Natural rubber is the most prone to attack, which is normally restricted to the surface in contact with the water. In sewage pipes, the attack may be concentrated in the area of the mean sewage flow. High levels of rubber weight loss (up to 33 percent) have been observed without apparent leakage, but the possibility of mechanical failure cannot be ignored.

Deterioration can occur in pipelines carrying groundwater, surface water, or sewage. Unchlorinated waters, or waters in which the chlorine residual has disappeared, would appear to support higher rates of attack than those in which a residual may still be detected. In certain instances, several rings showing deterioration have been recovered from the same section of pipeline, suggesting that the phenomenon may be widespread.

Rings less than four years old do not show attack, but there is an increasing tendency for rings older than this to show deterioration. This is most marked in rubber rings recovered from pipelines laid between 1950 - 1960. The timing would indicate that this might be associated with changes in rubber formulations which were necessary to protect the health of workers in the rubber industry.

The incidence of attack does not seem to be specifically associated with ring diameter. However, there is a distinct tendency for deterioration to be most marked in asbestos-cement pipes and least in iron mains. Initially,

this was considered to reflect the preference of the actinomycetes, which may attack rubber, for the alkaline conditions found in the joint spaces of asbestos-cement pipes. However, laboratory studies have shown that the formulation of some rubber rings used for the assembly of asbestos-cement pipes could make the rings more susceptible to deterioration.

Examination of large numbers of rubber rings has indicated that roughening and surface erosion are often symptomatic of biological attack. Two selective media, Kuster and Williams agar (Kuster and Williams, 1964) and modified DST (Orchard and Goodfellow, 1974), were used for the examination of both deteriorated and undeteriorated sections of the same ring; it was shown that actinomycetes are a significant factor in deterioration. Irrespective of the origin of the rubber ring, three morphological types were predominant; these have been identified as Streptomyces litmanii, Streptomyces fulvoviridis, and Nocardia asteroides (Hutchinson, et al., 1975). These were clearly the types described as white and orange-pink streptomycetes by other authors (Dickenson, 1969; Leeftang, 1963; Rook, 1955). Numbers as large as  $10^5$  to  $10^6$  per g. of deteriorated rubber have been recorded. The ability of these isolates to degrade rubber has been confirmed by inoculation of a rubber latex film supported on an aqueous agar base. The organisms grow and alter the physical properties of the rubber, confirming their ability to degrade the polymer. The ability of these actinomycetes to use certain rubber ingredients as sole carbon sources has also been demonstrated.

Other workers (Berridge, 1951; Thaysen, et al., 1945) have commented on the involvement of sulfur-oxidizing bacteria, which are capable of producing significant levels of sulfuric acid when growing on excess sulfur present in sulfur-vulcanized rubbers. This strong acid could cause a chemical deterioration of the rubber. Although these organisms were found to be associated with deteriorated rubber, it was considered that their presence was more directly related to the sewage environment, in which reduced sulfur compounds, namely hydrogen sulfide, were freely formed (Hutchinson, et al., 1975).

The importance of rubber formulation in controlling the rate at which a ring is attacked was clearly shown in a series of accelerated aging tests performed at the WRC using thin strips of rubber. These showed that unprotected natural rubber is rapidly degraded, but can be protected by

the use of antioxidants, especially those which are insoluble in water as reported earlier by Derham (1975) and Dickenson (1969). Chlorinated waxes and aromatic processing oils also have a beneficial effect in improving the resistance of natural rubber, but to a lesser extent than that afforded by antioxidants. The presence of relatively high concentrations of organic accelerators, such as thiocarbamates and thiurams, has a beneficial effect on the resistance of natural rubber to biodeterioration, as was found by Cundell and Mulcock (1973). However, some ingredients, especially plasticizers, may enhance the rate of deterioration and in separate tests, some, especially sodium octonate, were found actively to support the growth of rubber-degrading bacteria.

Although changes in the formulation of natural rubber may delay the onset of microbial attack, they will not prevent it from eventually happening. Whether careful selection of ingredients (especially antioxidants) that are currently acceptable to the rubber industry will protect rubber jointing rings for the 50 years' service life normally expected by water engineers is not clear from the short-term trials that have been done. The demands of the water industry for rubber formulations which are not toxic and do not permit the growth of microorganisms is a further complication in the selection of satisfactory rubber seals.

b. Biodeterioration of Sealants and Mastics. A sealant is intended to maintain a seal between the sides of a joint which may be subject to some degree of movement. In the water industry, sealants are primarily to control the movement of water, preventing both loss and contamination of water held in various concrete and steel tanks. In addition to good mechanical performance, sealants used in water supply must show minimal toxicity for mammals and must not support the growth of microorganisms. The National Water Council approvals procedure [See Section F.3.d] will protect the consumer from deterioration in water quality caused by these two factors. Additionally, the service life of the sealant must not be limited by microbial degradation.

WRC has assessed, for signs of microbial attack, sealants which have lost their mechanical properties. The following indices and microorganisms have been studied: colony counts, fluorescent pseudomonads, actinomycetes (including *Nocardia* sp.), sulfur-oxidizing bacteria, sulfate-reducing bacteria, and fungi. In strong contrast to the findings with rubber sealing rings, no specific microbial cause for deterioration could be found. Invariably,

the specific organisms likely to cause microbial deterioration (pseudomonads, actinomycetes, and fungi) have been found in no higher numbers than are present in neighboring unattacked material, the surrounding water environment, or in the case of filters, no more than is present in the adjoining sand. However, the Metropolitan Water Board (1970c) has shown that an ascomycete, possibly Herpotrichiella sp., was associated with disintegrated polysulfide sealants.

It is possible that sealants, because their formulations differ greatly (especially with respect to their higher levels of plasticizer) from those of rubber sealing rings, are more prone to a generalized attack by a variety of microorganisms that are capable of exploiting a less restrictive environment. At present, it is not possible to say whether the service life of sealants is primarily controlled by physical-chemical aging accentuated by chemical leaching, or whether microbial activity can be considered a limiting factor. However, it must be accepted that the working life of a sealant will be considerably less than that of a rubber ring and is unlikely to exceed ten to fifteen years.

## 2. Microbial Growth On Resins and Filter Media

In a technologically developed country, the drinking water is relatively free of bacteriological and aesthetic problems. However, only a small proportion of this domestic water is actually ingested by consumers as a beverage or in food; the remainder, probably over a hundred times the amount that is ingested, is used for hygienic, cleansing, or technical purposes. Whereas this water may be of good quality from the standpoint of health, it may have properties that make it unsuited to its alternative uses. Therefore, it may be necessary to eliminate certain ions from the water or to add special preparations so as to minimize technical difficulties.

In a household, filtration or ion exchange devices may be used to eliminate taste and odor-producing substances or bacteria, or to soften hard water in order to improve the performance of hot water equipment. Water can also be softened by adding substances that contain phosphorus, such as polyphosphates or ortho-phosphates, in order to prevent corrosion or encrustation within the pipes. This equipment may be installed behind the tap in an apartment or in the

basement of homes. Alternately, filters or small ion exchange boxes may not be connected to the distribution system, but may instead, be used separately as adjuncts to a specific household task. These small devices are often advertised for use while traveling and camping, especially to areas where sanitary conditions are suspected of being poor and disease is endemic. On the whole, these apparatus are unnecessary in households of the developed countries and can be ineffective and even dangerous when used in areas where there is epidemic disease. Although useful in their specialized technical roles, they are apt to create bacteriological problems in the process.

a. Filters. There is usually no need to use filters for removal of bacteria in households of developed countries. This is already accomplished by the municipal supplier. However, filters (mainly of activated carbon or some plastic compound) are advertised as a means of eliminating objectionable tastes, odors, colors, and turbidity in the water. It is well known that bacteria, along with organic matter, can collect within filter pores providing a suitable environment for microbial growth. Periodic cleaning of the filter becomes necessary to avoid large swells in bacterial populations emanating from the filter. Since publically supplied drinking water normally is free of pathogens, those bacteria which multiply in the filter are more a nuisance than a health hazard. Nevertheless, if there are legal codes limiting the acceptable colony count levels, this can create administrative problems.

b. Ion Exchangers. Ion exchange resins can produce bacteriological problems not only from attachment of bacteria and organic matter to the resin, but also from components of the resin itself that can serve as a nutrient source. Frequently, newly purchased ion exchange resins may already have defects in the individual resin granules. As a rule, these defects will increase during the life of the exchanger. Bacteria can very easily collect within these surface irregularities and be protected from disinfection, backwashing, or other cleaning attempts. Similar problems may be seen with filters and can lead to high microbial loads in the product [See Section E.4].

c. Portable Filters. As has already been mentioned, portable filters are intended to produce good quality water in areas where it is otherwise unobtainable. However,

portable filters are also advertised for use at camp sites or during times of emergency. Therefore, they should be designed so as to be capable of removing not only pathogenic bacteria, but also viruses, protozoa, and helminthic eggs that may be present in contaminated water. The small size of viruses dictates the need for extremely small pore diameters, which greatly reduces potential filtration speeds. Often, after a short period of use, the filter becomes clogged and will stop filtering altogether. Thus, effective portable filters are likely to be inconvenient, and convenient portable filters are likely to prove unsafe.

d. Water Softeners that Add Phosphorus. Unlike ion exchangers and filtration units, phosphate-dosing equipment adds small amounts of phosphate to the drinking water. Legislation in some countries specifies an upper limit for phosphate that can be present in the drinking water. Dosing with phosphate is useful only if the water is not too hard and the temperature of the water is about 60°C. Phosphate should not be added to a cold water supply because at low temperatures it encourages the growth of bacteria and (if light is available) algae, especially if there is any degree of stagnation. There is also the danger that phosphate preparations will not be handled properly in transit from producer to consumer, this too can result in contamination of water with bacteria. Provision of nutrients to bacteria already present in the water, plus introduction of new bacterial species, possibly pathogens, are potential problems connected with the use of phosphate preparations. It is, therefore, recommended that such preparations be divided into small portions and durably packaged before sale.

e. Conclusion. Small-scale water treatment apparatus for use in the field is frequently unnecessary or unreliable. Some devices fail to remove the microbes that they are supposed to take out of water, whereas others encourage microbial growth so that colony counts are increased in the treated water. The latter problem is also encountered when filter media, such as activated carbon [See Section E.5] or ion exchange resins, are used on a large scale; however, it is less of a nuisance when the treatment is being done by professionals and will be followed by disinfection.



### 3. Hydraulic Effects of Microbial Growth

Water from all public supplies must be delivered under pressure, whether its destination is a tap in the tallest skyscraper or the last tap at the end of a large distribution system. Pressure is necessary not only to supply people quickly with a desired volume of water, but also to maintain hygienic conditions. Flowing water seldom permits bacterial growth, and a properly functioning distribution system will maintain an adequate flow to ensure against microbiological problems.

a. Types and Diameters of Pipes. Often, the type of pipe used, or its diameter, will have an effect on bacterial growth, especially at locations in the home where a continuous flow of water is not guaranteed because of infrequent usage. Comparative studies with plastic, rubber, copper, and steel pipes showed that colony counts increased from one to 14,000 per ml in the rubber pipe; whereas steel and plastic pipes had colony counts of about 30, and the copper pipe showed a count of about zero after four days of use. Plastic material must be tested for use with drinking water because plastic paints and covers used in closed reservoirs very often lead to problems with bacterial growth.

In some buildings, especially in schools, the diameters of pipes in the distribution system are calculated for emergency cases (e.g., fire) and not for routine drinking water supply. This means that the amount of water being regularly used is small in comparison to the pipe diameters. The result can sometimes be stagnation and taste and odor problems, especially if drinking water pipes are installed near heating pipes where elevated temperatures will promote bacterial growth. Streptomyces species are especially adapted to taking advantage of such situations, imparting an earthy taste and odor to the water.

b. Microbial Oxidation of Manganese in Pipes. Certain bacteria, including Pseudomonas sp., Hyphomicrobia, and Sphaerotilus discophorus can form oxides of manganese in water containing > 0.01 to 0.05 mg per l or more of manganese within a pH range of 6 to 7.5. These manganese oxides adhere to pipe walls forming ripples across the direction of flow, which invariably leads to losses in pressure. It has been shown (Schweisfurth and Mertes, 1962) that, at high

flow rates, the hydrodynamic effects in pipes become significant, leading to a substantial drop in pressure; whereas, at low flow rates, pressure changes are inconsequential. Pipes in which such a build-up has occurred, can be restored to good operating condition with mechanical cleaning, albeit the process is cumbersome and time-consuming. Alternatively, chlorination can be used to inhibit microbial activity; with chlorine, oxidation also takes place, but the end product, Mn (IV) does not adhere to pipes and can be removed by filtration.

c. Microbial Growth from Improper Installation of Household Equipment. The installation of dishwashers, washing machines, ion exchangers, or filtration units must take into account pressure differentials between the household water supply and equipment capacities. If some means of compensation is not also installed, back-siphonage and contamination can result. Rubber tubes are often added to the tap to extend use to the bottom of bathtubs or sinks. Turning water outlets in different locations of the house on or off can sometimes be sufficient to create hydraulic pressure changes and to flush contaminated bathing or washing water into the distribution system. Such events have been responsible for the occurrence of enteric disease in inhabitants of one household or several households along an entire street.

d. Microbial Growth from Cross-Connections. Industrial buildings and ships, in particular [See Section G.5], are known to have two or more distribution systems: one for drinking water supply and another to supply low quality water for other uses, such as cooling or fire protection. If these industries are situated near a large river or harbor, they very often use raw river or harbor water for these latter purposes. Normally, the two systems must be separated from each other by special instrumentation to ensure that no mixing occurs. In some cases, pressure in the water pipes used for fire protection is higher than that which is in the drinking water pipes and small amounts of contaminated water may continuously drip into the drinking water system. If this "inoculum" is derived from polluted river water, pathogens may be not only introduced, but may find conditions suitable for multiplying. If at any time, the slide valve is opened, the danger of contamination is greatly increased. Over the last 30 years, outbreaks of typhoid fever, paratyphoid-B fever, and salmonellosis have

resulted from such cross-connections and pressure differences in distribution systems of this kind. Therefore, two systems handling different quality water and operating side-by-side must be carefully controlled and supervised.

#### 4. Microbially Mediated Chemical Cycles

a. Microbial Manganese Oxidation Affecting Wells and Water Distribution Systems. Manganese-oxidizing microorganisms (bacteria, fungi, and very rarely protozoa) require a treatment separate from that for "iron bacteria" because only a few of the rare species of chlamydobacteria oxidize or precipitate both iron and manganese under natural conditions or in the laboratory. The references to reports of both iron and manganese oxidation by Siderocapsaceae are incorrectly quoted in most cases (Schweissfurth, 1973). Enzyme-mediated iron or manganese oxidation cannot be proved solely on the basis of microchemical detection of Fe (III) or Mn (IV) at the sheaths of the surfaces of these bacteria.

By contrast to Fe (II), Mn (II) is oxidized by  $O_2$ , at a rate that is of practical significance in the field of drinking water, only above a pH value of approximately 8 to 8.5. Correspondingly, reduction of Mn (IV) already occurs at Eh values near or below + 200 mV; this means that the microbiological oxidation of Mn (II) can only take place above this Eh value (Schweissfurth, 1972).

Depending on the geological and hydrological conditions in the aquifers or reservoirs, Mn (II) is formed from Mn (IV) by reduction or dissolved from manganese carbonate by reaction with  $CO_2$  or  $HCO_3^-$ . In the case of waters with little or no dissolved oxygen, the Mn (II) penetrates into the wells and into the raw water, where, in the presence of  $O_2$ , microbial oxidation starts, as well as the formation of "MnO<sub>2</sub>" (=  $MnO_{1+x}$ ,  $x = 0.7$ ) and the formation of deposits in the wells and water conduits. The problems caused by these deposits include clogging of slots in well pipes; increased turbulence and thus, a loss of flow velocity in conduits; damage to equipment for measuring water flows; black-colored water; stains in laundry; disturbances in food handling establishments; accumulation of heavy metals such as arsenic, lead, zinc, and copper (Basco and Szalay, 1978); and sometimes an increase in the colony count of the water. Prevention is based on elimination of Mn (II) from raw water if limit values of 0.01 to 0.05 mg per l are exceeded. Based on the conditions under which Mn (II) and Mn (IV) are

stable (Hem, 1963-1965), Mn (II) can only be oxidized, within the Eh and pH ranges common for drinking water, by microbiological means. Various bacteria (Sphaerotilus discophorus, Pseudomonas, Arthrobacter, and Hyphomicrobium species), as well as fungi, induce manganese oxidation (Schweisfurth, 1978). Apparently only in the case of Hyphomicrobium manganoxidans is there an interdependence between the multiplication of microorganisms and manganese oxidation (Schweisfurth, et al., 1978).

The removal of manganese from raw water at a treatment plant can be accomplished either by chemical or microbiological means if conditions are adjusted. The chemical manganese oxidation is carried out by aeration, pH values, that is induced by the  $MnO_{1+x}$  already formed. During the microbiological removal of manganese, the medium of a filter serves as a support for the growth of microorganisms (mostly gram-negative, rod-shaped bacteria and in rare cases, sphaerotilus discophorus and manganese-oxidizing fungi). It is essential that the Eh value of the water be sufficiently high (more than + 200 mV); otherwise, manganese oxidation does not start, even after an inoculation with backwash sludge from another plant. If there is no removal of manganese in a microbial water treatment plant, no manganese-oxidizing microorganisms will be detectable by culture.

Formation of a high proportion of manganese-oxidizing growth on the inner surfaces of water pipes has not been shown to be directly related to corrosion.

b. Iron and Sulfur Bacteria Corroding Well Casings and Other Structures. Bacteria may take part in the corrosion of iron well pipes and drinking water conduits. In each case, corrosion may start from either the inside or the outside. Except for the coating of pipes against exterior corrosion, protective measures such as bituminizing or plastic coating afford only a partial protection.

In this discussion, the term "iron bacteria" will include: (1) bacteria suspected of being capable of drawing an energetic benefit from the oxidation of  $Fe^{++}$  to  $Fe^{+++}$  (Gallionella, possibly chlamydobacteria such as Leptothrix); and (2) bacteria utilizing the organic ligand from complex-bound  $Fe^{++}$ , following which  $Fe^{++}$  is subject to oxidation by  $O_2$  at pH values above 5, such as are found in drinking

water. The latter bacteria, which are mostly rod-shaped, may also precipitate complex-bound  $\text{Fe}^{++}$ .

The term "sulfur bacteria" will include: (1) sulfur-oxidizing bacteria that, being autotrophic, will generally oxidize reduced sulfur compounds to  $\text{SO}_4^{--}$ , mainly under aerobic conditions; and (2) sulfate-reducing bacteria that, at a locally or generally low Eh value and in the absence of  $\text{O}_2$ , form hydrogen sulfide using both organic hydrogen donors and molecular hydrogen.

Microbially mediated corrosion (i.e., a dissolution of elemental iron and other metals) will occur as a consequence of: (1) absorption of nutrients, as well as oxygen, by the colonies of microorganisms that have accumulated at the metal surface; (2) liberation of corrosive metabolites, such as organic acids and other complex-forming compounds; (3) production of sulfuric acid from  $\text{S}^{--}$  or elemental sulfur; and (4) inclusion of sulfate-reducing bacteria in the cathodic process under anaerobic conditions. Both natural and artificial anti-corrosive coatings are also subject to microbial attacks. Although the types of corrosion mentioned in (1) and (2) are assumed to occur only under conditions in which nutrients are plentiful (as is true in cooling systems), they may also play a role in interior corrosion within drinking water distribution systems.

The chemical and microbiologic processes involved have been summarized by Chanterreau (1977). Subtle heterogeneity in the system can lead to the establishment of foci of anodic and cathodic depolarization, enabling electrolysis and metabolic activity of iron bacteria and, given a sulfur source, of sulfur bacteria as well [See Figure G.4.b-1]. As iron from the pipe is being eroded in the form of  $\text{Fe}^{++}$  ions, various derivative substances are being deposited on the inner surface of the pipe, sometimes to an extent that occludes the bore of the pipe substantially [See Figure G.4.b-2]. Maturation of the deposits leads to the presence of an anaerobic zone nearest the pipe surface and an aerobic zone in contact with the water, as well as an intermediate zone of low oxygen activity: this allows iron bacteria and both sulfur-reducing and sulfur-oxidizing bacteria to participate in the corrosion and deposition process [See Figure G.4.b-3].

In addition to their participation in corrosion processes, the iron bacteria have both favorable and unfavorable effects on the procurement and treatment of raw water

FIGURE G.4.b-1

## CYCLE OF BIOLOGICAL CORROSION

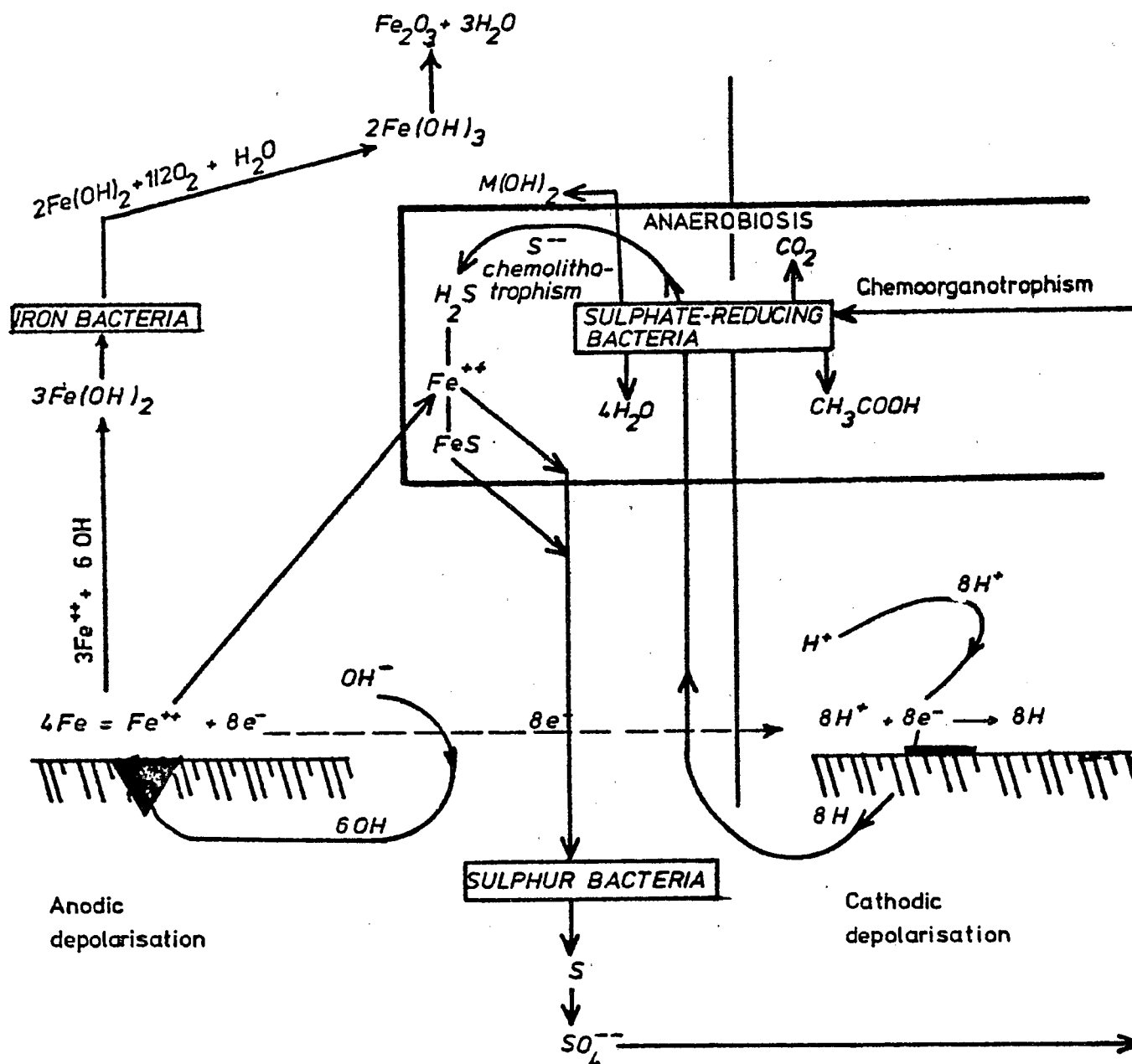

From Chantereau, 1977.

FIGURE G.4.b-2

FORMATION OF DIFFERENT FORMS  
OF IRON DEPOSITS IN WATER PIPES

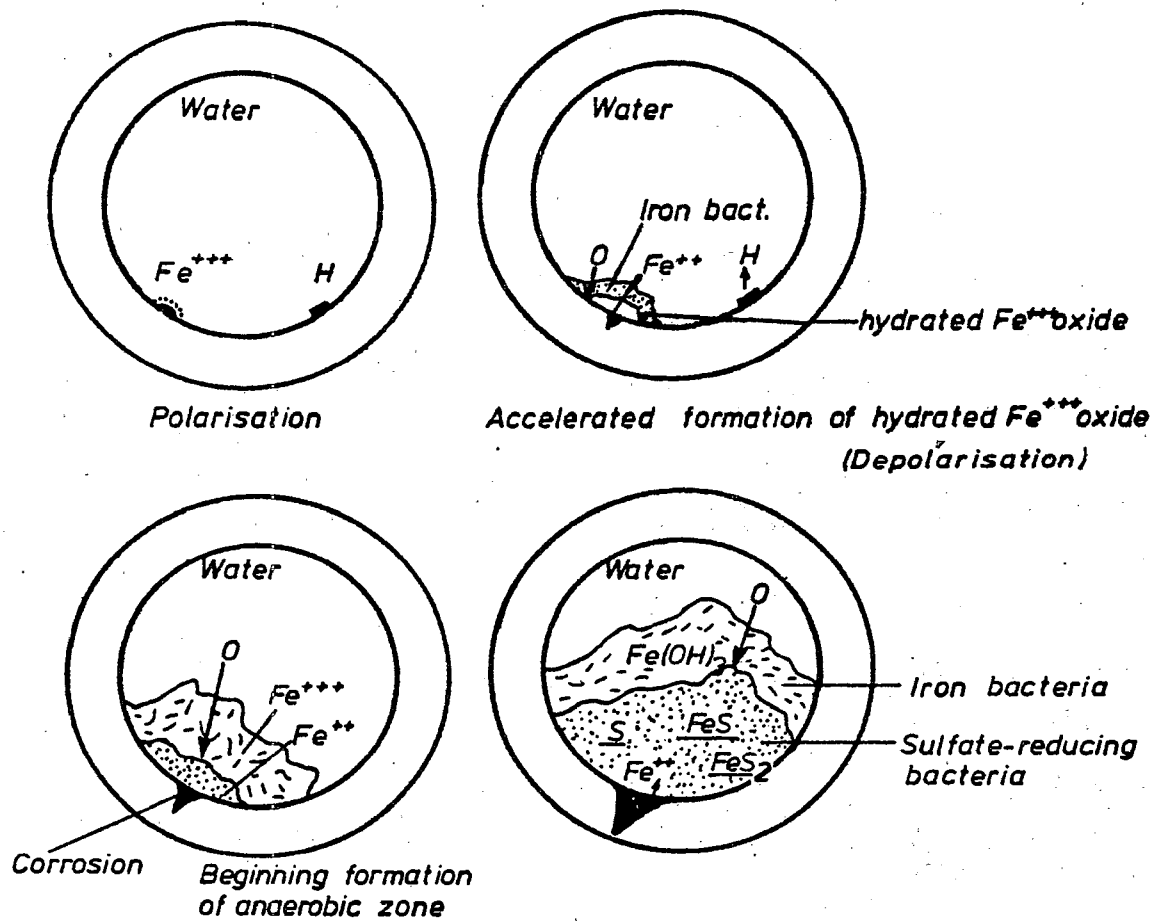

From Chantereau, 1977.

FIGURE G.4.b-3

SCHEMATIC REPRESENTATION OF A SECTION  
OF A SO-CALLED RUST KNOB

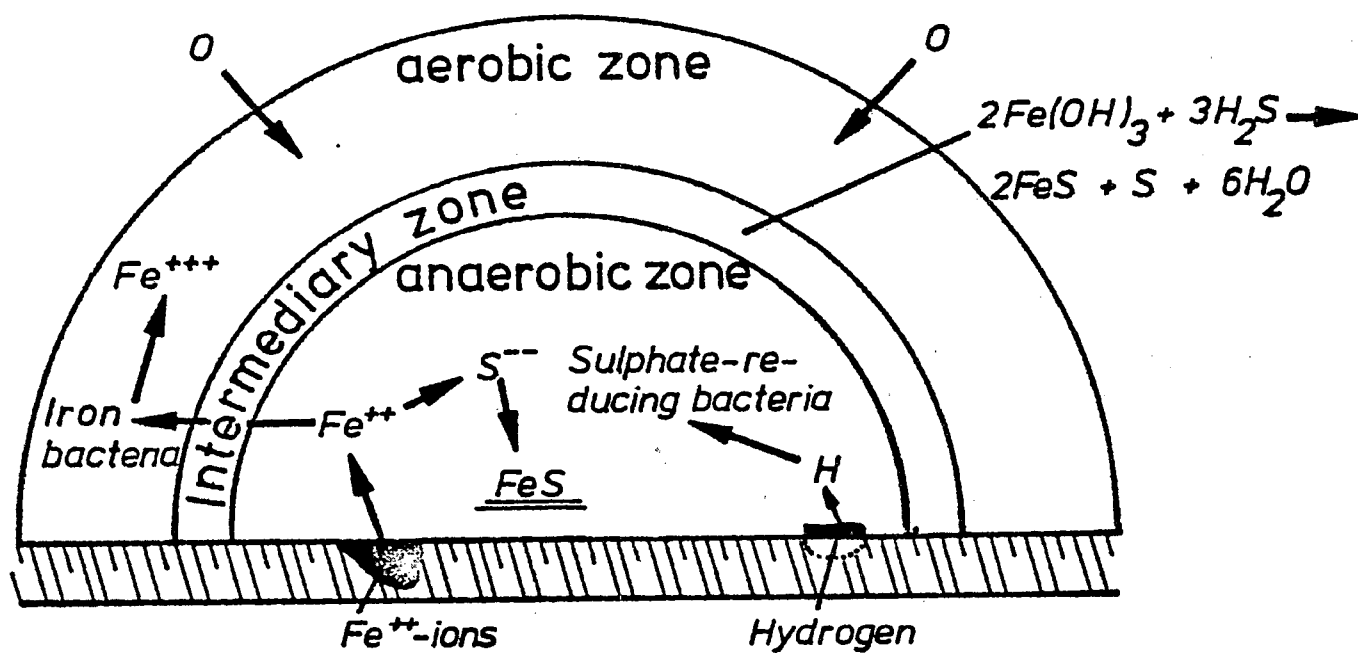

From Chantereau, 1977.



for the production of drinking water (Glathe and Ottow, 1972; Kullmann and Schweisfurth, 1978; Schulze and Schweisfurth, 1975). During procurement, they will accelerate  $Fe^{+++}$  precipitation when oxygen has entered the aquifer and the groundwater, and will thus, reduce the water-permeable cross-section of all structures (in the soil and in slotted well-pipes), thereby eventually resulting in failure of the well [See also Sections A.1.b to c and A.2.a(ii)]. On the other hand, the iron bacteria certainly take part in the breakdown of organic substances during the process of iron removal from waters, which opposes the precipitation of  $Fe^{+++}$ . These bacteria are also found where iron is precipitated within distribution networks [See Section F.2.d(vi)].

The problems caused by iron and sulfur bacteria have been described as briefly as possible in this discussion. In addition to the references cited above, valuable and much more extensive information will be found in Iverson (1975), Lovelock and Gilbert (1975), and Miller (1971).

#### 5. Drinking Water Supply for Ships

Many countries have no regulations for ensuring good quality drinking water aboard ships (Müller, 1976; Goethe, et al., 1969) although a disproportionately high frequency of waterborne infections are known to occur on these vessels compared with incidences on land. A serious problem with shipboard water lies in the fact that many ports only have contaminated water (sometimes containing helminth eggs, protozoa, bacteria, and/or viruses) available to fill ships' tanks and because this water does not undergo any treatment or purification during storage.

Being confined on a ship means that both passengers and crew cannot avoid infection if water supplies are contaminated with pathogens; hence, outbreaks aboard ships tend to be epidemic. These not only include common waterborne diseases (e.g., typhoid fever, paratyphoid B fever, other salmonellosis, cholera, and dysentery), but also infections caused by large concentrations of opportunistic pathogens (e.g., *P. aeruginosa*, as well as *Clostridium*, *Bacillus*, and *Staphylococcus* species). This latter group, if incorporated into food through the addition of contaminated water, may become enriched in the process (Muller, 1974).

a. Occurrence of Contamination Aboard Ships. Investigators have found that the bacteriological quality of ships' drinking water is, on the average, inferior to that of land water. For example, from 1950 to 1960, 25 percent of the ships docking at the Hamburg harbor had water which tested positive for E. coli (Müller, 1961). In 1970, the Japanese found high total bacterial and coliform counts in drinking water from nearly 50 percent of their vessels (Hayashi, et al., 1975). They later reduced the proportion to 27 percent in 1974 by adding sterilization and filtration equipment.

b. Why Ships' Water Becomes Contaminated. Observations made over a 20-year period have revealed several areas of neglect which are largely responsible for contamination of water supplies on ships. They are listed in order of their frequency of occurrence:

- Drinking water kept in open tanks during conveyance aboard lighters.
- Using the same bucket for drinking water as well as for river water.
- Tracking dirt from shoes into tanks during cleaning operations.
- Using river or sea water to clean tanks.
- River or sea water seeping into improperly closed tanks.
- Using the same hoses and pumps for both drinking water and river water.

c. Water Distribution Systems on Ships. Ships possess either a single, double, or triple distribution system. The single system, theoretically, provides potable water throughout the entire distribution network. Large, recently built ships are likely to have this arrangement, now that equipment for distilling salt water has provided an alternative to refilling tanks from water supplies of foreign harbors.

The double system conveys finished water for drinking and washing through one network, while river or sea water travels through a separate pipeline to water closets, ship cleaning, and fire protection facilities.

The triple system channels river water into showers and sinks for hand and dish washing; sea water into a network for fire protection, ship cleaning, and toilets; and drinking water into only a few taps, primarily for that purpose alone.

d. Types of Disinfection Practiced on Ships. Disinfection can be accomplished by physical or chemical means. These processes include boiling; filtration; or applying chlorine, silver, ozone, or ultraviolet irradiation.

The cost and bulky apparatus needed for boiling make this process impractical for use on ships. As for filters, they may become defective or clogged and they require careful maintenance, backwashing, and bacteriological monitoring of the filtrate (Müller, 1975) all of which require expertise not commonly available on board a ship.

The effectiveness of chlorine disinfection depends on maintaining an active residual in spite of possible high loads of organic matter; this can give rise to problems of taste and odor. Furthermore, automatic devices which utilize gaseous chlorine, and electrolytic processes for deriving chlorine from sodium chloride, can malfunction on a stormy sea.

Relatively small quantities of silver are bactericidal or bacteriostatic. If the dose is high enough and contact time long enough, adequate disinfection can result. Moreover, silver is easy to handle and maintains its potency for long periods of time.

Ozone has not, as yet, been employed on ships because of fire and explosion hazards associated with it, as well as the sensitivity of the production mechanism. Neither does it offer prolonged disinfection since, being toxic, it must be removed from the water.

Ultraviolet irradiation disinfects quite well, but only when applied to relatively clear, "colorless water already somewhat low in microorganisms (Müller, 1972). Unfortunately, a ship's movement during stormy weather can stir up sediment in the water tank and create problems of turbidity which prevent the ultraviolet light from adequately penetrating the water.

Distillation is the method of choice for providing drinking water on ships, although it too has its problems.

One great advantage of this technique is the availability of source water, once a ship is on the open seas. This limitless capacity obviates the need for strict conservation or priority uses, practices which may endanger the quality of the water.

Inasmuch as vacuum distillation may be done in the temperature range of 25 to 40°C, it will not protect against pathogens and should not be considered a substitute for boiling. A properly operated still will produce water with a chloride content below 6 mg/l, but the chloride test does not indicate microbiological purity. It is recommended (Muller, 1968) that distillation be used in conjunction with chlorine or silver, but that highly polluted waters (such as one may find in a harbor) not be used at all in this process.

e. Bacterial Standards for Drinking Water on Ships. All water used on ships for drinking, food preparation, and hand washing should conform to drinking water standards [See Section D]. This means that 100 ml of water sample should contain no E. coli or total coliforms. Because it is situated so close to polluted surface waters, ships' drinking water should, in addition, be monitored for total bacteria, in which no more than 1,000 per ml are an acceptable number. Pseudomonads (along with coliforms) are typical inhabitants of polluted surface waters. They can grow rapidly in low nutrient water and at low temperatures (e.g., in ice water). Because of these attributes and because P. aeruginosa is a potential pathogen, a test for these organisms should be included among microbiological analyses of ships' water. Culturing on gelatin pour plates will reveal any pseudomonads as green fluorescent colonies.

f. Emergency Drinking Water Storage. In case of shipwreck, consideration is first given to obtaining enough water. Water quality and safety, therefore, become issues of secondary importance.

Provision of sufficient amounts of potable water is one way of combating deficiencies during emergencies. The International Commission (International Ship Safety Treaty) specifies that quantities of 3 l per person be stored on lifeboats and 1.5 l per person on life rafts. These supplies are usually stored in plastic tanks (though formerly wooden or metal tanks were used) and fastened under the

thwarts. Water may also be contained in sterilized plastic bags or tins which, due to expense and number of processing steps, are usually reserved for life rafters. To avoid contamination after filling with good quality water, silver compounds are added, thereby permitting storage for three years or longer (Müller, et al., 1977). Also available are several small devices for converting sea water to drinking water, such as ion exchangers or distillers, which may be installed on life boats and life rafts.

## 6. Water in Containers

Microbiologically safe, piped water is available to most people in the industrialized nations a majority of the time. In these countries, water is put into containers and sealed for two principal reasons: (1) to have it available in the event of an emergency in which normal supply is interrupted; and (2) to allow water from a specific source to be distributed commercially over a wide area. The maintenance of water quality during prolonged storage in a container presents some special problems (Müller, 1969; Sepilli, et al., 1965).

a. Water for Emergencies. Water stored in containers for emergencies might be prepared in either of two ways: first, water of adequate bacteriologic quality might be sealed in containers just as it comes from the public supply. Second, water may be sealed in containers (tins, plastic bags, or glass vessels) and sterilized. Depending upon the level of organic matter present, water that has not been sterilized is likely to permit bacterial growth to reach colony counts of millions per milliliter unless some long-acting disinfectant such as silver salts is added. Sterilized water will remain bacteriologically acceptable for a virtually unlimited period of time, depending only on the integrity of the container.

The container is, therefore, the key to successful storage of water for emergencies. Tins sometimes oxidize, especially at the edges, so that metallic (tin or iron) ions or products become dissolved in the water. The resulting color, turbidity, and astringent or metallic taste impair the organoleptic quality of the water. Plastic bags appear to offer some comparative advantages, in that they are light in weight, and visible changes in water quality will be perceptible without opening the container. However, they

are more susceptible than tins to physical damage and occasionally impart off flavors (described as musty, foul, or not fresh) to the water if appropriate polymers are not chosen [See also Section F.3.b].

b. Commercially Distributed Water. For centuries, people have gone to certain wells and springs to drink or bathe in the waters as cures for, or to mitigate, symptoms of rheumatism and biliary or renal concretions, or to stimulate intestinal motility. More recently, water from such sources has been put into bottles (first of glass, but now more often of plastic) and sent all over the world. In addition to the renowned sources, commercially distributed water may simply derive from wells in which mineral content is known to be high (mineral water) or come from wells or public systems and then be supplemented with salts and carbon dioxide gas (bottled drinking water). Water bottled without carbon dioxide "still bottled water" may be preferred by those whose stomachs are upset by carbonation. Bottled water is favored in Europe because people are sensitive to the tastes and odors of chlorine and other substances present in tap water or because tap water is thought to be hazardous to health. Bottled water has become an item of great economic importance, partly because advertising has led people to believe it to be more healthful than tap water. Nevertheless, water cannot be assumed safe simply because it comes from a bottle. It must produce low bacterial colony counts and be free of fecal indicators, pathogens, and potential infectious agents as well as toxic chemicals. The bacteriologic quality of commercially distributed water should remain as good as that of tap water [See Section D] even through prolonged periods of storage at room temperature.

c. Bacteriological Quality of Water in Containers. Water in containers may contain bacteria which were present in the source water [See Section A] or may be contaminated in the process of bottling, through contact with contaminated containers or closures, or by contaminated air [See also Section F.3.d]. This means that the bacteriological quality of both the source water and the product in the final container must be continually monitored (Geldreich, et al., 1975). Water that has just been sealed into a container should be free of coliforms and E. coli and should have a colony count no higher than that of the source water. Sporeformers sometimes associated with food poisoning and

enteric diseases (e.g., Clostridium perfringens and Bacillus subtilis) should also be absent. Pseudomonas species have been a problem when certain plastic containers or caps with plastic inserts are used, and high counts of P. aeruginosa [See Section B.1.a(vii)] have been found in many samples of water bottled without carbonation (Müller, 1974; Soenke, 1974). Bacterial activity in the product may also give rise to toxicologic problems; given a high initial nitrate level, bacterial nitrosification may yield levels of nitrite which are hazardous to newborn and young children, for whom bottled water is especially recommended.

d. Storing Water in Containers. Whether publically supplied or commercially packaged, drinking water will invariably harbor a few indigenous microbes whose numbers, under entirely normal circumstances, will increase as a function of time, temperature, and available nutrients. However, when water is stored in containers, initial counts of ten to twenty colonies per ml may soon grow to populations numbering in the millions per ml. Later, after three weeks to three months of storage, colony counts should decrease as a result of nutrient depletion. Such a swell in bacterial numbers can be prevented during bottling by the addition of disinfectants, such as silver salts, or by filter sterilization. Carbon dioxide in the water will help to inhibit growth of the indigenous flora, but will not kill pathogens or fecal indicators such as E. coli. Therefore, when analyzing samples it is important to look beyond total colony counts which, especially in the case of carbonated water, may prove misleading. Along with the standard fecal indicators [See Sections C.1.c to d], tests for pathogens (such as P. aeruginosa) [See Section C.2.c] and potential pathogens (such as aerobic and anaerobic sporeformers) [See Section C.1.e] should be routinely employed.

## 7. Summary

Bacteria are classified, and subsequently identified, on the basis of the limited circumstances under which they can grow and the nutrients they can use. Although individual bacterial genera and species may be extremely limited in versatility, there always seems to be one or more species capable of growing in any given aqueous environment regardless of adverse conditions, extremes of temperature, or apparent absence of nutrients. Growth of such organisms in drinking water treatment, storage, and distribution facilities often proves detrimental to the facilities or to the quality of the water.

Facilities are structurally affected by deterioration of materials and by some of the chemical reactions that can lead to mobilization of iron in water mains. The functioning of facilities is affected when deposits of microorganisms and their products interfere with hydraulic conduction through water pipes or coat the active surfaces of filter media. Water quality may be degraded by inappropriate storage or by treatment in small-scale apparatus, the design of which is not microbiologically sound.

The importance of sanitation, in limiting the microbial inoculum that may give rise to these technological problems, must not be minimized. However, it must also be recognized that drinking water is almost never sterile, that organisms which may cause problems will eventually be encountered in every situation, and that only active measures against such organisms can be expected to succeed in the long term.

#### 8. Recommendations

1. Construction materials used in treatment and distribution systems should be selected (among other factors) according to their resistance to biodeterioration. Those components that are prone to microbially-induced deterioration should receive appropriate servicing and be replaced as they near the end of their life expectancies.
2. Devices used in the home, primarily for the sake of convenience, as adjuncts to household tasks are apt to create bacteriological problems and should be avoided or professionally controlled.
3. Water, destined for public consumption, that is supplied in non-standard form (e.g., aboard transport conveyances or packaged commercially) should be subject to the same microbiological standards of quality enforced for publicly supplied water.



## H. SUMMARY

The most potentially significant constraint upon the scope of the microbiology project is that it was to address the drinking water supply problems of industrialized nations. As was stated in the introduction to this report, industrialized nations usually have large quantities of water or industrialization would not have been possible. Even so, the quantities of water may not be adequate to meet anticipated needs and the quality of available water may be much degraded by prior use. It is well, at this point, to ask what distinctive features of water supply in industrialized nations are significant to microbiology.

>As major feature is high daily per capita water use. Daily consumption of beverage water is physiologically determined: the body's water losses must be replaced, so the total daily use of water, by ingestion, is determined by the climate and the size of the population in both industrialized and developing countries. Other uses of water in the home, which tend to be larger in industrialized nations than in developing countries, include flushing of water-carriage toilets and cleansing of food, clothing, the home, its contents, and its inhabitants. Outside-the-home uses that contribute to the high daily per capita demand in industrialized nations include a variety of applications in commerce and industry, as well as the occasional use of water for fighting fires.

Where the volume of water used exceeds the supply, a  
⇒ "reuse factor" (e.g., perhaps 25 percent of the water available at some point in a certain river has already been used somewhere upstream) may be calculated. Some classes of water  
> reuse are of far greater microbiologic concern than others. For example, human feces, and therefore, the water used to eliminate them from a household, are the most significant sources of infectious agents transmissible through water. By contrast, the direct disposal of human waste into waterways, that occurs in some parts of the world (either from ships and boats on the water or from unsewered communities  
⇒ along the banks), may decrease the calculated reuse factor,

but increase the risk of waterborne disease. Other microbiologically significant components of used water include substances which may support the growth of organisms in the water, and heat. Project Area V of this CCMS Pilot Study addresses the broader aspects of water reuse, but reuse must also be considered in the context of drinking water microbiology because the majority of the infectious agents that might be transmitted by drinking water derive from the human intestines and are carried by wastewater, in some proportion, into waters that may serve as drinking water sources. The problem of preventing waterborne infectious diseases would be greatly mitigated if an appropriate, non-polluting alternative to the water carriage toilet could be developed; such a device would be accepted only if it met the esthetic standards now prevalent in industrialized nations. Otherwise, the protection of source waters demands that wastewater discharges be carefully supervised and that wastes be treated and disposed of in a manner that permits water to be reclaimed as necessary. Many features of this problem are considered in Project Area V and, in the specific context of groundwater protection, in Project Area VI.

Topic A of the microbiology report concerns Raw Water. Every community or water supplier should, and ordinarily will, select the purest available source for use in drinking water production. Groundwater from a deep, protected aquifer may contain only a few microorganisms, none of which is of intestinal origin. Water of this kind may be used in both private and public supplies with little or no treatment. Even then, chlorination may have to be used in public systems to avoid problems in distribution. However, really well-protected aquifers in some areas may lie at such a depth that they are not accessible to private users. The depth of an aquifer may be less of a problem where public water supplies are concerned, but the quantities of water available must be adequate to the community's needs, or less pure raw water will have to be used.

Groundwater is frequently discharged to surface waterways after use (and, one would hope, after treatment), but increasing efforts are being made to dispose of wastewater in such a way that the groundwater will be recharged. The success and safety of this method of water reclamation depend greatly upon the ability of soil to accomplish microbiologic purification of the water between the point of application and the aquifer or, at least, the point of abstraction of water from the aquifer. The efficiency of

purification will depend on the rate of application, on the character of the soil, and on whether recharge is undertaken by vertical infiltration under the influence of gravity or by pressure injection directly into the aquifer. This artificial recharge must be done with extreme caution, for the microbiologic purification of water by soil is not a well understood process and once contamination of a groundwater source has occurred, it is extremely difficult to correct. This is an area where a great deal of research is needed; until results are available, it will be prudent to treat wastewater, to be used for groundwater recharge, to a degree that does not demand too much of the purifying capacity of the soil. The introduction of viable organisms to an aquifer is not the only microbiologic concern in groundwater recharge. Some microbially-induced chemical transformations can lead to degradation of groundwater and toxins liberated upon the death of microbial contaminants may also prove significant.

Surface sources of raw water are more difficult to protect from microbial contamination and will frequently support the growth of some of the organisms that may be introduced. Airborne contamination and runoff from adjacent land surfaces, in addition to discharged wastewater, may contribute undesirable organisms or nutrients to surface waters. Surface water quality may also be directly affected by human activities such as recreational swimming and boating, residence in houseboats, or navigation on waterways for commercial transport of goods. Under optimal conditions, microbial counts in lakes, extremely rich in nutrients, may exceed  $10^6$  per ml. Many organisms in surface waters are capable of inducing undesirable chemical transformations. Photosynthetic bacteria and cyanobacteria (formerly called blue-green algae) can grow to high levels, given favorable conditions and adequate light. These bacteria, as well as the true algae, can induce off-flavors in water, bind large quantities of dissolved oxygen under certain circumstances, and physically interfere with water purification. Toxins produced by some cyanobacteria may also be significant to human health. It is clear that surface waters which serve as sources of drinking water need more rigorous protection than many of them get, but it is also clear that more research will be needed before the requisite protective measures are well understood.

Topic A also includes a survey of the microbiologic quality of at least some of the raw water in nine different countries. Not surprisingly, raw water quality is generally better where the source is groundwater and where it originates in less densely populated areas. Even in these situations, raw water quality is seldom so consistently excellent that one-step treatment can safely be trusted. Where raw water quality is poorer, more intensive treatment methods are generally employed. Finished water of adequate quality and safety can evidently be produced by a series of unit processes ending with disinfection; but the community served is, obviously, more vulnerable to any kind of event that might even temporarily interrupt treatment of the water before distribution.

#### Recommendations Concerning Raw Water

1. More research should be done on the microbial ecology of groundwater.
2. The microbiologic quality of source waters should routinely be tested, especially in those instances where the quality of the raw water is judged so good as to require only minimal treatment.
3. Laws to protect both groundwater and surface water sources should be more restrictive and specific, and should include adequate provision for enforcement.
4. Means of conveying good quality raw water to areas where source water quality is deficient should be investigated further.

Topic B surveys the specific Pathogens that may be transmitted through drinking water. Generally, these are infectious agents including bacteria, viruses, protozoa, and metazoa. The proximate source of these agents in water may vary, but most of them ultimately derive from the human intestines. Intestines of other warm-blooded animals are an alternate source of some waterborne agents infectious to humans and only a very few of these agents are apparently capable of living free in the environment for extended periods of time. Although the agents discussed are all of concern to human health, the majority of the infections caused by them are mild or asymptomatic. This fact tends

to complicate the investigation of waterborne disease outbreaks, in that the majority of infections may go unrecognized unless intensive and wide-ranging laboratory testing, frequently of fecal specimens, is undertaken.

Although quite long periods of persistence in water have been reported for some pathogens, the aqueous environment is not generally a favorable one for human infectious agents. Physical and chemical factors, as well as competition or predation by better-adapted indigenous microbial species, combine to kill or inactivate pathogens in water with the passing time. Other things being equal, higher temperatures and longer detention times favor the destruction of greater quantities of waterborne pathogens. However, it is important to note that most time-dependent death processes occur as logarithmic functions of time, so that the level of the dying agent, theoretically, never reaches absolute zero. This raises the dual questions of how sensitive a method must be for detecting a waterborne pathogen, and what significance to human health may be represented by some small residual level of a pathogen in water. These two questions may or may not be intimately interrelated. It is often argued that, as difficult as pathogens frequently are to detect in water, there is no need to develop methods to detect them at levels below which they represent a threat to health. However, there are those who believe that no level of an infectious agent is so low as to be insignificant to human health and that sample-to-sample variation offers the possibility that water sent to the laboratory for testing may contain less contaminant than water that someone drinks from the same source, so there is no limit to the desired level of sensitivity in testing for waterborne pathogens.

Further research is needed both to determine the relative threat to human health that is presented by different levels of a pathogen in water and to develop more sensitive methods for detecting waterborne pathogens. However, there is also a need for simpler methods of detecting waterborne pathogens, in that more samples, tested by more laboratories, may eventually produce a more useful body of information, to aid in producing a safer supply of water, than would the testing of a few very large water samples by the few laboratories that are equipped to deal with them. Even if these were available, tests for pathogens could not afford a basis for routine quality control in drinking water supply. Given the problems inherent in detecting waterborne pathogens, it is not surprising that microbiologic testing of water is focused, instead, upon indicators.

### Recommendations Concerning Pathogens

1. Even where water is protected, as is true of many groundwater sources, disinfection is recommended. This is especially important where finished water is to be stored rather than being used immediately.
2. Aftergrowth of opportunistic pathogens during distribution of finished water should be prevented by maintaining a chlorine residual throughout the distribution network, especially in large systems.
3. Testing for pathogens within the distribution water is appropriate: (a) after contamination is found to have occurred; (b) to trace the source of an outbreak; and (c) in analyzing disinfection efficiency.
4. Given the lack of correlation between viruses and the bacterial indicator systems, more research on the antiviral effectiveness of various water treatment processes is needed.
5. Mapping of waterborne outbreaks should be conducted in conjunction with epidemiological surveys of the population served by the water supply.

Topic C of this report deals with Indicator Systems, which are microbiologically-based quality control methods. Indicator systems already established in use are generally based upon enumeration of viable organisms on a selective basis. Some, but not all, of these indicators are supposed to correlate with the occurrence of fecal contamination and, implicitly, with the presence of enteric pathogens. The closeness of correlation between different established viable indicator systems and fecal contamination varies greatly. Where correlations are low, it is usually either because the organisms measured may include some that are not of fecal origin at all or some that are capable of proliferation in the environment outside of the body. Another potential liability, where disinfection is practiced, is that the indicator organisms may be more sensitive to the disinfectant than are some of the enteric pathogens which might be present. In addition to indicators of fecal contamination, there are indicator systems that gauge water quality

and others that serve to signal the presence of specific pathogens. Finally, there is always reason to wish for indicator systems that are more rapid or simpler to apply; such systems could permit more replication of tests.

These considerations led to the inclusion in Topic C of a survey of proposed alternate indicator systems based upon viable microbes, including coliphages and animal viruses, as well as a number of groups of bacteria. Some of these may eventually serve special purposes on a regular basis, but none is presently ready to supplant the "established" indicators for routine quality control in drinking water treatment and distribution. Other indicator systems surveyed are not based on determining numbers of viable organisms, or at least may not require incubation through many microbial generation times before results are obtained. Some of these alternate systems seem to offer significant potential for continuous monitoring of water quality in situations where rapidly obtained results will permit prompt remedial action. No system considered would obviate the need for proper sampling techniques or for adequately trained laboratory personnel.

Topic D surveys Testing and Standards for drinking water in various countries. For the time being, microbiologic quality control of drinking water, in most of the countries surveyed, is based upon the coliform group. However, in some countries, thermo-tolerant coliforms or Escherichia coli (based on a working definition of the species) are determined instead or in addition to the coliforms. Procedures for both sampling and testing are seen to vary from country to country, but the differences are not so great that the coliform test results cannot be compared. The general intention in every case seems to be that coliforms (or thermo-tolerant coliforms or E. coli, as the case may be) should be absent from samples of finished drinking water taken at the treatment plant or, in many instances, throughout the distribution system. Unfortunately, the survey that was done did not yield adequate bases for comparing methods of laboratory quality control; nor was it possible to determine how corrective action is taken in the event that indicators are found in finished drinking water. Efforts being made by several organizations to standardize analytic procedures in water microbiology are certainly to be commended. Whatever the analytic procedures used, it seems clear that the ability of laboratory microbiology to contribute to the safety of drinking water depends less on how standards are written than on the dedication with which they are applied or enforced.

Topic E deals with the Treatment Methods used in producing finished drinking water. The emphasis in this case is on how various unit processes affect pathogens and indicator systems. However, much information on other aspects of some of the same treatments can be found in the reports of Project Area II: Advanced Treatment Technology. The variety and degree of treatment used in preparing drinking water should be, and usually are, determined by the quality of the raw water that is available. Where the source is variable in quantity or quality, reservoir storage may be used to buffer some of the fluctuations. The primary function of the reservoir may be storage, but considerable changes, for better or worse, can result from holding water in a reservoir. This depends on whether the reservoir is managed so as to minimize opportunities for contamination or growth of noxious organisms and to make use of the water's tendency for self-purification; at best, storage of water in a reservoir can serve as a treatment step, and is regarded as such in this report. Physical treatments, such as coagulation and flocculation or various versions of sand filtration, serve to remove suspended matter including many microbial cells. These treatments are especially important in removing protozoan cysts and metazoan eggs, as well as in eliminating suspended matter that might interfere with disinfection. Slow sand filtration, and often activated carbon treatment, have an important biological component. Activated carbon treatment is intended, primarily, to remove impurities that are dissolved, rather than suspended, in water. To the degree that the substances removed might have served as substrates for microbial growth, the growth becomes less likely to take place in the water, but more likely on the carbon surface. This will not necessarily produce a health hazard, but it can lead to disinfection problems and to a decrease in water palatability. The microflora in slow sand filters can effect important reductions in biodegradable dissolved substances, especially in water pre-treated with ozone.

The ultimate defense against carry-over of pathogenic bacteria and viruses into finished water is, ordinarily, disinfection. If pathogens were unlikely to have been present in the raw water, disinfection may be done solely to suppress opportunistic organisms and to avoid technical problems during distribution of the water. This requires use of a disinfectant such as chlorine, a residual of which can be maintained throughout the distribution network. On the other hand, disinfection may be needed to kill large numbers of microorganisms, possibly including pathogens.



Ozone is seen to be a major alternative to chlorine in this application; it is already well established as a primary drinking water disinfectant in many areas. Other disinfectants are also surveyed, and some of these may eventually capture a portion of the disinfection market. It is important to note that no disinfectant can make good water from bad, and that disinfection may fail if water has not first been treated in a manner appropriate to its original quality, so that the disinfectant has only to act upon reasonable numbers of microorganisms.

Topic F addresses the problem of maintaining finished water quality during Storage and Distribution. This represents a special challenge from both the standpoints of quality and safety. On the one hand, the quality of finished water at the treatment plant must be assumed to be the best that can be achieved with the means available, so that storage of finished water, for example, can maintain or degrade quality, but cannot improve it as in the case of raw water storage. On the other hand, the epidemiological record shows that cross-contamination and back-siphonage, by introducing raw sewage or otherwise polluted water into finished water in distribution, have been relatively important among causes of the rare outbreaks of disease associated with public water supplies. The most general problems are those of avoiding growth of organisms present in the finished water (for example, by maintaining an active level of chlorine in water throughout the distribution network) and preventing contamination of the finished water from external sources (for example, by covering service reservoirs in which finished water is stored). The materials and the manner of construction of the facilities are critical at every stage. Water contact surfaces in reservoirs and in mains all too frequently include materials which may support microbial growth. The joints that have been well designed to exclude contaminants from without are sometimes found to present favorable conditions for microbial growth within the system. Older materials used in constructing water distribution systems all have disadvantages, including increasingly high costs of production and installation and, in some instances, exceedingly short service lives when in contact with the water of some communities. Newer materials and joint designs appear to offer important advantages; but the testing of these cannot always include all of the conditions to which they will be subjected in use at various places. Thus, unforeseen difficulties are always possible, even under what may be described as routine conditions.

- Butt, C.G., Baro, C. and Knorr, R.W. (1968) Naegleria sp. identified in amoebic meningoencephalitis. American Journal of Clinical Pathol. 50:568-576.
- Butterfield, C.T. (1948) Bactericidal properties of chloramines and free chlorine in water. U.S. Public Health Rep. 63:9340-9349.
- Butterfield, C.T., Wattie, E., Megregian, S. and Chambers, C.W. (1943) Influence of pH and temperature on the survival of coliforms and enteric pathogens when exposed to free chlorine. Public Health Rep. 58:1837-1866.
- Butzler, J.P., Dekeyser, P., Detrain, M. and Dehaen, F. (1973) Related Vibrio in stools. Journal of Pediatrics 82:493-495.
- Cabelli, V.J. (1977) Indicators of recreational water quality. In Bacterial Indicators/Health Hazards Associated with Water ASTM STP 635, pp. 222-238 (Edited by Hoadley, A.W. and Dutka, B.J.), American Society for Testing and Materials, Philadelphia.
- Cabelli, V.J. (1979) Evaluation of recreational water quality, the EPA approach. In Biological Indicators of Water Quality (Edited by James, A. and Evison, L.M.) Pub. Wiley, London.
- Cabelli, V.J., Dufour, A.P., Levin, M.A. and Haberman, P.W. (1976) The impact of pollution on marine bathing beaches: An epidemiological study. In Proc. Symposium on Middle Atlantic Continental Shelf and the New York Bight, Special Symposium # 2 (M. Grant Gross, editor). The American Society of Limnology and Oceanography, Inc., New York City, pp. 424-432.
- Cady, P. (1975) Rapid automated bacterial identification by impedance measurements. New Approaches to the Identification of Microorganisms pp. 73-99 (Edited by Heden, C.G. and Illeni, T.) John Wiley & Sons, Inc., New York.
- Cady, P. (1978) Progress in impedance measurements in microbiology. Mechanizing Microbiology, pp. 199-239 (Edited by Sharpe, A.N. and Clarke, P.S.) Charles C. Thomas, Publisher, Springfield, Illinois, U.S.A.

pipes may be degraded by microbial action, either because the organisms were able to use the material of the pipe as substrate or because microbial metabolism caused minerals to be eroded from or deposited on the inner surfaces. Microbial cells themselves, and the slimes associated with some of them, are able to coat resins and filter media or the interiors of pipes so as to exert a direct adverse physical effect upon the function of the facility. It is not surprising that resin function would be extremely susceptible to microbial growth, given the fact that normal function of the resin depends upon intimate interaction between the resin surface and the water; however, it is also true that a thin microbial slime coat can significantly interfere with the hydraulic conductivity of a water main, even though the deposit obstructs very little of the inside of the pipe.

Another set of technological problems involves the storage of water aboard ships, and in containers for commercial distribution or for use in emergencies. In a way, one might assert that drinking water in these contexts needs to be even purer than that in public supplies, for these classes of stored water will ordinarily be used in exactly the condition that the consumer receives them. Problems associated with ships' water supplies are discussed in detail; some of these problems are shared with supplies of drinking water aboard all classes of public conveyances, but they may be more extreme with ships because longer periods of storage and greater volumes of water are involved, and because many opportunities exist for cross-contamination from wastewater, water from the ship's bilge, and wash water derived from the often-polluted water in which the ship floats. Water sealed in containers also requires great care, as to the initial quality of the water, the use of preservatives (if any), and the selection of a container. Obviously, those who must use packaged water in times of disaster will have no opportunity at that point to reject that which, on the basis of off-flavor, odor, or appearance, might be suspected of being toxic. On the other hand, those who regularly drink bottled water in their daily lives place their trust in the safety of the commercial product and are therefore vulnerable to any lapse on the part of the bottler or distributor.

This report necessarily emphasizes water treatment and control measures for routine use. However, it must be recognized that emergencies do arise and that plans for dealing with them should be made beforehand, as much as possible. Causes of emergencies, in what may be descending order of likelihood, include undetected deterioration in the

physical apparatus, human error, power failures, adverse weather, willful mischief, earthquakes, and war. Both apparatus at the treatment plant and in the distribution network may be subject to deterioration or sudden malfunction. Human errors might include such events as construction machinery breaking water mains. Loss of electrical power could inactivate pumps, ozone generators, and vital control apparatus. Adverse weather can cause power failures; or extreme cold, floods, or windstorms may directly interfere with water treatment or distribution. Willful mischief would include any malicious act by which one or a few persons abused a water system in an effort to disrupt society. Earthquake prediction seems to be progressing, but is still not very useful for protecting water supplies. Finally, if war occurs, water systems may be disrupted incidentally to general bombardment, overtaxed through excessive water demand for firefighting, or directly targeted as a vehicle for biological warfare.

All communities are vulnerable to emergencies affecting their water distribution systems. However, there are potential differences, involving water sources and treatment, in susceptibility to emergencies. A community that has relatively low-quality water must use a complex treatment scheme and is vulnerable from that standpoint. On the other hand, a community that derives very pure source water from a deep aquifer will have no water at all if it loses its pumping capacity. Large water supply systems probably present more points of vulnerability than small systems, and communities that derive their water from distant sources are especially at risk.

If treatment is interrupted, but distribution is maintained, microbiologic safety can be achieved by drawing water from the tap and boiling it. Otherwise, any available water that does not contain acute toxicants may have to be boiled and used. Restoration of treatment and distribution services are likely to require extensive flushing and use of large quantities of chlorine to restore a system to normal; plans for such action should be made in advance, and key personnel should learn their tasks. Large communities, where great numbers of people might be unable to supply themselves with water in the event of a system stoppage, should consider storage of water for emergencies in moderate-sized containers at well-distributed and marked locations.

Industrialized nations in general share a relatively high level of public health, as measured by long life

expectancies and low child mortalities, which is at least partly a tribute to the technical and institutional success of drinking water supply in these countries. Even private water supplies in these countries are often monitored on a limited basis, so that relatively few inhabitants use water that has not been safety tested in some manner. It is, perhaps, noteworthy that the primary safety criteria applied, even to this day when many other aspects of drinking water safety are under scrutiny, are based upon microbiologic indicator systems. This is reasonable, for a great part of the public health gains that have been achieved in industrialized nations have resulted from reduced incidence of infectious diseases through sanitation. Hardly any aspect of drinking water microbiology would not be likely to benefit from further research, but it is important to note that presently available treatment techniques, monitoring methods, and other features of current drinking water supply practice are serving their purposes remarkably well. In a general sense, standards presently in effect must never be relaxed because the populations of industrialized nations, accustomed to a high level of sanitation, are likely to be quite vulnerable to any abrupt lapse in established drinking water practice.

Change is inevitable, however, and new classes of chemical contaminants are being identified in wastewaters and in some raw waters from which drinking water must be produced. Aspects of these problems are discussed in Project Areas I and IV. Research is needed both on effective and feasible methods for protecting source waters and on modified disinfection methods that will produce fewer undesirable disinfectant derivatives while serving the original purpose of disinfection, which is to kill as many microorganisms as possible in the water. The task of protecting source waters, from a microbiologic standpoint, will be aided when more research results are available regarding detection methods for waterborne pathogens, as well as the probability of infection as a function of ingesting different quantities of waterborne pathogens. Indicator systems that are intended to signal fecal or other microbiologic contamination of water might be further refined and standardized, but it seems likely that monitoring the adequacy of water treatment and disinfection could better be based on the development and application of a separate set of indicator systems. These, and indicator systems designed to detect recontamination of finished water in distribution, probably stand to be most improved by automation or modification to afford shorter readout times. In this age of dramatically improved international communication, it seems clear that more standardization of criteria for water quality and safety will ensue.

If primary disinfection procedures must be modified out of concern for interactions between the disinfectants and chemical contaminants of water, further research will be needed on the adequacy of alternative disinfectants. At the same time, it will be very important to determine and attempt to utilize the antimicrobial effects inherent in all of the other unit processes employed in water treatment. Research to aid in protecting the quality of finished water during storage and distribution will, assuredly, focus on the development of low-cost, durable materials that are inert to the microflora in the water, but there are also many other research needs in this area. To the degree that microbial growth is capable of creating technologic problems, which have been enumerated previously, it is important that research contribute more to the understanding of these microbiologic processes, for it may be that the organisms cannot be entirely suppressed, but only minimized. Finally, further research on the evaluation and maintenance of water quality in closed containers is still needed.

Many new concerns about drinking water safety have been raised in recent years. Because these are generally chemical in nature and may be associated with such dire effects as cancer, they have tended to overshadow the microbiology of drinking water. Under the circumstances, it seems fitting to close by pointing out that: (1) the primary criteria of drinking water safety and quality are based upon microbiologic indicator systems; and (2) in any major lapse in drinking water treatment and distribution practices, the most immediate consequences to consumer health are more likely to be caused by pathogenic microorganisms than by chemicals.

## GENERAL RECOMMENDATIONS

1. Every public water supply should begin with the highest quality raw water that is available in quantities sufficient to meet the community's needs. Efforts to protect and improve the quality of source waters are important; both waste discharges and non-point sources of pollution should be considered in attempts to prevent or alleviate contamination. Where possible, water to be used for irrigation or for industrial purposes other than food, drug, or cosmetic manufacture, should usually be drawn from less pure sources than those from which the public supply derives.
2. Disinfection is necessary, but not always sufficient, to ensure the safety of drinking water from virtually any source.
3. Complete treatment of drinking water, including at least coagulation and sedimentation with sand filtration or alternatively dual filtration including effective slow sand filtration, followed in all cases by disinfection, is essential in all cases where source waters are unprotected and is highly desirable even with protected sources.
4. Sound engineering practice is required to produce safe drinking water; microbiologic laboratory testing performed on a routine basis, according to standardized methods, and by properly trained and supervised staff is an important basis for assessment of drinking water quality. Indicator systems for use in these tests may be selected for any one of the following purposes: (i) to signal fecal contamination; (ii) to detect any abnormal and probably undesirable conditions that may occur; or (iii) to warn of the probable presence of specific pathogens. Larger waterworks, at least, should develop microbiologic quality control procedures and baseline data for all stages of treatment from raw water through distribution. Prompt corrective action

should be taken when norms are exceeded. At least one microbiology laboratory in each country should have the ability to detect waterborne pathogens, either for spot-checking or for investigating outbreaks, both from water samples and from clinical specimens. Results of tests for both indicators and pathogens should be recorded through a focal national center and shared on an international basis.

5. Innovative indicator systems, capable of signaling fecal contamination, problems in treatment efficiency, loss of integrity of the distribution system, and perhaps the presence of pathogens, should continue to be sought. Rather than try to find a single indicator system that will serve all of these disparate functions at once, emphasis should be placed on individual systems offering convenience and economy that will allow more frequent testing.
6. In addition to the well-established research on waterborne bacterial pathogens, considerably more research is needed concerning viruses and protozoa transmissible by drinking water, in the areas of the dose-dependence of peroral infectivity and pathogenicity, the detection of these agents in water, and their removal or destruction by water treatment and disinfection processes.
7. Monitoring of raw water quality on the basis of appropriate indicator systems is desirable in all cases and essential in those instances where the usual purity of the raw water is such that less than complete treatment is used. At least one indicator system that is directly correlated with fecal contamination should be included; the choice of other indicator systems to signal other kinds of problems should be made on the basis of knowledge about local conditions.
8. Materials of which water treatment and distribution facilities are constructed should be pretested for chemical and biological stability. Testing methods, as well as results, should be shared internationally as much as possible; however, it is also best to test materials, before use in a given system, with the very water with which they will, in fact, be in contact.
9. Finished water in distribution, in both public and semipublic systems, should be sampled at representative locations and tested microbiologically with a frequency



that depends on the size of the population served. Private water supplies should be tested at least annually. In all instances, the presence of coliforms, thermo-tolerant coliforms, or E. coli in a 100-ml sample should be treated as unacceptable, or at the very least, undesirable.

10. To minimize aftergrowth or other technological problems and to provide a means of determining whether cross-contamination has occurred, water in public supply distribution should wherever possible contain a measurable residual level of disinfectant (e.g., chlorine) at all points.
11. Inasmuch as distribution systems are a potential source of problems in all water supplies, every system should be under continuous surveillance. Where problems are identified, they should either be eliminated by modification of the system or be mitigated by routine maintenance procedures.
12. Procedures for the installation and repair of water mains should be established beforehand and applied diligently when needed. Plans for dealing with emergencies should be made and communicated, in advance, to those responsible for implementing them.
13. Means are needed to control cross-connections, to ensure both that the consumer does not degrade publicly-supplied water to the detriment of his own health and that his use of the water does not cause contamination that threatens the health of others. To achieve these objectives, plumbing codes may need revisions and better enforcement with respect to water supply systems in buildings, to attachment devices that use water, and to point-of-use treatment units attached to the consumer's tap.
14. More intensive research and epidemiologic surveys are needed to determine the true health effects of microbes and their products in finished drinking water. For this purpose, closer cooperation and communication are needed among practicing physicians and veterinarians, public health authorities, and water microbiologists. Any proposed change in treatment, distribution, or quality control practice should be evaluated from the standpoint of probable impact on public health, as far as possible, before implementation.

## REFERENCES

- Adamek, R., Daubner, I., Johnová, V. and Tržilová B. (1977) Preliminary tests of the influence of wastewaters from sugar factories upon the numbers of intestinal bacteria in water. Ztl. Bakteriol. Hyg. Abt. I, orig. B 164, 340-351.
- Adams, M.H. (1959) Bacteriophages. Interscience Publ., Inc., New York, 592 pages.
- Afghan, B.K., Ryan, J.F., and Tobin, R.S. (1977) Improved method for quantitative measurement of adenosine triphosphate in lake waters, activated sludges and sediments. Environmental Analysis, pp. 29-45 (Edited by Ewing, G.W.) Academic Press, New York.
- Ahearn, D.G. (1974) Identification and ecology of yeasts of medical importance. In Opportunistic Pathogens, pp. 129-146 (Edited by Prier, J.E. and Friedman, H.) University Park Press, Baltimore.
- Ahearn, D.G. (1978) Medically important yeasts. Ann. Rev. Microbiol. 32:59-68.
- Ahmed, K.Y. (1975) Survival of bacteria in turbid and polluted waters. M.S. Thesis, New Mexico State Univ., 39 pages. Available from National Technical Information Svc., 5285 Port Royal Rd., Springfield, Va. (Rept. #PB-268801).
- Ainsworth, R.G., Ridgway, J. and Gwilliam, R.D. (1978) Corrosion products and deposits in iron mains. Proc. Conf. Water Distribution Systems, 1978. Paper 8, Session 2, Publ. Water Research Centre, Medmenham.
- Alexander, M. (1971) Microbial Ecology. John Wiley & Sons, New York, 467 pages.

- Alexopoulos, C.J. (1962) Introductory Mycology, 2nd edition. John Wiley & Sons, New York, 613 pages.
- Allen, J.M. and Geldreich, E.E. (1975) Bacteriological criteria for groundwater quality. Ground Water 13:1-7.
- Alonso, J.M., Bercovier, H., Servan J., Bourdin, M. and Mollaret, H.H. (1976) Contribution a l'etude epidemiologique des infections a Yersinia enterocolitica. II. Enquete ecologique. Med. Mal. Infect. 6:434-441.
- American Public Health Association (1976) Standard Methods for the Examination of Water and Wastewater, 14th edition. American Public Health Assoc., Washington, D.C., 1193 pages.
- Andre, D.A., Weiser, H.H. and Malaney, G.W. (1967) Survival of bacterial enteric pathogens in farm pond water. J. Am. Waterworks Assoc. 59:503-508.
- Annapurna, E. and Sanyal, S.L. (1977) Enterotoxicity of Aeromonas hydrophila. Journal of Medical Microbiol. 10:317-323.
- Anon (1974) Gesetz zur Gesamtreform des Lebensmittelrechtes. 15.8.1974, BGesbl. I, S. 1945.
- Appleton, H. and Buckley, M. (1977) Virus-like particles in winter vomiting disease. Lancet, Feb. 19, 409-411.
- Appleton, H. and Pereira, M.S. (1977) A possible virus aetiology in outbreaks of food-poisoning from cockles. Lancet, Apr. 9, 780-781.
- Ator, L.L. and Starzyk, M.J. (1976) Distribution of group D streptococci in rivers and streams. Microbios 16:91-104.
- Atterholm, I., Hallberg, T., Ganrot-Norlin, K. and Ringertz, O. (1977) Unexplained acute fever after a hot bath. Lancet, II, 684-686.
- Aurand, K., Hasselbarth, U., Muller, G., Schumacher, W., Steuer, W. (1976) Die Trinkwasserverordnung Erich Schmidt Verlag, Berlin, 255 pages.
- Baars, J.K. (1957) Travel of pollution and purification en route in sandy soils. Bulletin of the World Health Organization 16:727-747.

- Bachrach, U. and Bachrach, Z. (1974) Radiometric method for the detection of coliform organisms in water. Appl. Microbiol. 28:169-171.
- Bachrach, U. and Friedman, A. (1971) Practical procedures for the purification of bacterial viruses. Appl. Microbiol. 22:706-715.
- Bagley, S.T. and Seidler, R.J. (1978) Comparative pathogenicity of environmental and clinical Klebsiella. Health Lab. Sci. 15:104-111.
- Baker, M.N. (1934) Sketch of the history of water treatment. J. Am. Wat. Wks. Ass. 26:902-938.
- Barua, D. (1970) Principles and practice of cholera control. Public Health Papers, World Health Organization 40:29-31.
- Basco, J. and Szalay, A. (1978) Accumulation of arsenic, lead, and other heavy elements in the iron-manganese oxide-hydroxide precipitation in the pipelines of city waterworks. The Science of the Total Environment 9:271-278.
- Bates, R.C., Shaffer, P.T.B., and Sutherland, S.M. (1977) Development of poliovirus having increased resistance to chlorine inactivation. Appl. Environ. Microbiol. 34:849-853.
- Baylis, J.R. (1936) The efficiency of rapid sandfilters in removing the cysts of the amoebic dysentery organisms from water. Public Hlth. Rep. 51:1567-1573.
- Becker, K. (1969) Die Verbreitung der Leptospirose bei Ratten in einer Grobstadt (Berlin). Schriftenreihe Wa-Bo-Lu, 32:49-66.
- Bedulevich, T.S., Svetlakova, M.N., and Trakhtman, N.N. (1953) New data on the use of chlorine dioxide in water purification. Gig. Sanit. 19:14-17.
- Bell, J.F. and Stewart, S.J. (1975) Chronic shedding tularemia nephritis in rodents: Possible relation to occurrence of Francisella tularensis in lotic waters. Journal of Wildlife Dis. 11:421-430.

- Benarde, M.A., Israel, B.M., Olivieri, V.P., and Granstrom, M.L. (1965) Efficiency of chlorine dioxide as a bactericide. Appl. Microbiol. 13:776-780.
- Benarde, M.A., Snow, W.B., Olivieri, V.P., and Davidson, B. (1967) Kinetics and mechanism of bacterial disinfection by chlorine dioxide. Appl. Microbiol. 15:257-265.
- Benson-Evans, K. and Williams, P.F. (1975) Algae and bryophytes. In Ecological Aspects of Used-Water Treatment 1:153-202 (Edited by Curds, C.R. and Hawkes, H.A.) Academic Press, New York.
- Berg, G. (1964) Devitalization of microorganisms by iodine. Virology 22:469-479.
- Berg, G. (1966) Virus transmission by the water vehicle. III. Removal of viruses by water treatment procedures. Health Lab. Sci. 3:170-181.
- Berg, G. (1967) Summary. In Transmission of Viruses by the Water Route, pp. 471-472 (Edited by Berg, G.) Interscience Publishers, New York, N.Y.
- Berg, G. (1973) Removal of viruses from sewage effluents and waters. Bull. World Health Organ. 49:451-469.
- Berg, G. (1978) The indicator system. In Indicators of Viruses in Water and Food, pp. 1-14 (Edited by Berg, G.) Ann Arbor Science, Ann Arbor.
- Berg, G. and Metcalf, T.M. (1978) Indicators of viruses in water. In Indicators of Viruses in Water and Food, pp. 267-296 (Edited by Berg, G.) Ann Arbor Science, Ann Arbor.
- Berg, G., Chang, S.L., and Harris, E.K. (1964) Dynamics of the devitalization of enteroviruses by elemental iodine. Virology 22:469-481.
- Berg, G., Dean, R.E., Dahling, D.R. (1968) Removal of poliovirus 1 from secondary effluent by lime flocculation and rapid sand filtration. J. Am. Wat. Wks. Ass. 60:193-198.
- Berg, G., Bodily, H.L., Lennette, E.H., Melnick, J.L. and Metcalf, T.G. (Editors) (1976) Viruses in Water. American Public Health Assoc., Washington, D.C., 256 pages.

- Berg, G., Dahling, D.R., Brown, G.A. and Berman, D. (1978) Validity of fecal coliforms, total coliforms, and fecal streptococci as indicators of viruses in chlorinated primary sewage effluents. Appl. Environ. Microbiol. 36:880-884.
- Berndt, H. and Linneweh, H.J. (1969) Comparative quantitative studies on the bactericidal activity of chlorine dioxide and chlorine. Arch. Hyg. Bakteriol. 153:41-46 (from Chem. Abst. 71, 29528e, 1969).
- Berridge, N.J. (1951) The deterioration of milking rubbers. I. The effect of microorganisms. J. Dairy Res. 18: 246-250.
- Beulow, R.H. and Walton, G. (1971) Bacteriological quality vs. residual chlorine. Journal of the American Water Works Assn. 63:28-35.
- Bhoonchaisri, P. (1979) An evaluation of differential media used to enumerate Bifidobacteria. M.Sc. Thesis, University of Newcastle upon Tyne.
- Bishop, R.F., Davidson, G.P., Holmes, I.H. and Ruck, B.J. (1973) Virus particles in epithelial cells of duodenal mucosa from children with acute nonbacterial gastroenteritis. Lancet, (ii), 1281-1283.
- Bisson, J.W. and Cabelli, V.J. (1979) Membrane filter method for Clostridium perfringens. Applied and Environmental Microbiol. 37:55-56.
- Bissonnette, G.K., Jezeski, J.J., McFeters, G.A. and Stuart, D.G. (1975) Influence of environmental stress on enumeration of indicator bacteria from natural waters. Appl. Microbiol. 29:186-194.
- Bissonnette, G.K., Jezeski, J.J., and McFeters, G.A. (1977). Evaluation of recovery methods to detect coliforms in water. Appl. Env. Microbiol. 33:590-595.
- Black, A.P., Kinman, R.N., Thomas, W.C. Jr., Freund, G., and Bird, E.D. (1965) Use of iodine for disinfection. J. Am. Water Works Assoc. 57:1401-1421.
- Block, J.C. (1977) Contribution à l'étude de la désinfection des eaux d'alimentation par l'ozone. These Doctorat d'Etat es-Sciences Pharmaceutiques, Nancy, France.

- Block, J.C., Morlot, M., and Foliguet, J.M. (1976) Problemes lies à l'évolution du caractere d'oxydabilité de certains corps organiques presents dans l'eau traitée par l'ozone. Techno. Sc. Municipales, L'eau 71:29-34.
- Block, J.K., Foliguet, J.M., Hartemann, P., and Joret, J.C. (1977) Etude comparative de l'action de l'ozone: Etudes comparatives sur les enterovirus et les bacteries. Unpublished paper presented at the 3rd World Ozone Congress (Paris, France, 1977), sponsored by the International Ozone Institute (now Association), Cleveland, Ohio.
- Block, J.C., Joret, J.C., Rolland, D., Richard, Y. and Foliguet, J.M. (1978) Elimination des bacteries et des virus au cours de la préchloration des eaux d'alimentation: Résultats préliminaires sur une station industrielle. Proceedings of the colloque "Eaux d'Alimentation et Santé Publique", Lille, France, in press.
- Boardman, G.D. and Sproul, O.J. (1977) Protection of viruses during disinfection by adsorption to particulate matter. J. Wat. Poll. Control Fed. 49:1857-1861.
- Bohm, A., Dreher, M., Gran, H., Hirmer, R., Lehrnbecher, M., Metz, H., Moritz, P. and Schmidt, H.W. (1978) On a dysentery epidemic (Shigella sonnei) in Ismaning. Off. Gesundh.-Wesen 40:643-652.
- Bolivar, R., Conklin, R.H., Vollett, J.J., Pickering, L.K., DuPont, H.L., Walters, D.L. and Kohl, S. (1978) Rotavirus in travelers' diarrhea: Study of an adult student population in Mexico. Journal of Infectious Dis. 137:324-327.
- Bond, W.W., Favero, M.S. and Korber, M.R. (1973) Bacillus; sp ATTC 27380: a spore with extreme resistance to dry heat. Appl. Microbiol. 26:614-616.
- Bonde, G.J. (1962) Bacterial Indicators of Water Pollution. Teknisk Forlag, Copenhagen.
- Bonde, G.J. (1977) Bacterial indication of water pollution. In Advances in Aquatic Microbiology, Vol. 1 (Edited by Droop, M.R. and Jannasch, H.W.) pp. 273-364, Academic Press, New York.

- Bonde, G., Grunnet, K. and Kristensen, K.K. (in press)  
Examination as to consequences of use of infiltration ponds.
- Boring III, J.R., Martin, W.T. and Elliott, L.M. (1971)  
Isolation of Salmonella typhi-murium from municipal water, Riverside, California, 1965. Amer. J. Epidemiol. 93:49-54.
- Bottone, E.J. (1977) Yersinia enterocolitica: A panoramic view of a charismatic microorganism. Critical Reviews in Microbiol. 5:211-241.
- Bowden, W.B. (1977) Comparison of two direct-count techniques for enumerating aquatic bacteria. Appl. Environ. Microbiol. 33:1229-1232.
- Brammer, K.W. (1963) Chemical modification of viral ribonucleic acid. II. Bromination and iodination. Biochem. Biophys. Acta 72:217-229.
- Brandrick, A.M., Newton, J.M., Henderson, G. and Vickers, J.A. (1967) An investigation into the interaction between iodine and bacteria. Appl. Microbiol. 30:484-487.
- Breidenbach, A.W. (1976) Toward a common language: Keynote address. In Environmental Modeling and Simulation, pp. 3-6 (Edited by Ott, W.R.) EPA 600/9-76-016, U.S. Environmental Protection Agency, Washington, D.C.
- Brenner, D.J., Steigerwalt, A.G., Falcao, D.P., Weaver, R.E. and Fanning, G.R. (1976) Characterization of Yersinia enterocolitica and Y. pseudotuberculosis by DNA hybridization and by biochemical reactions. Int. J. Syst. Bacteriol. 23:205-216.
- Brezenski, F.T. and Russomanno, R. (1969) The detection and use of salmonellae in studying polluted tidal estuaries. J. Water Pollution Control Fed. 41:725-737.
- Bringman, G. (1954) Determination of the lethal activity of chlorine and ozone on E. coli. Z. Hyg. Infect. 129:333-337.
- Brisou, J. (1975) Les levures et les champignons du milieu marin. Bull. Soc. Fr. Mycol. Med. 4:159-162.



- British Department of Health and Social Security (1969) The Bacteriological Examination of Water Supplies, Reports on Public Health and Medical Subjects, 4th ed., No. 71, Her Majesty's Stationery Office, London.
- British Standards Institute (1955) Rubber Joint Rings for Gas Mains, Water Mains and Drainage Purposes. British Standard BS 2494. B.S.I., London.
- Broadwater, W.T., Hoehn, R.C., King, P.H. (1973) Sensitivity of three selected bacterial species to ozone. Appl. Microbiol. 3:391-393.
- Brodsky M.H., and Ciebin, B.W. (1978) Improved method for recovery and enumeration of Pseudomonas aeruginosa from water using membrane filters. Appl. Environ. Microbiol. 36:36-42.
- Brown, O.R. (1973) Inhibition of Escherichia coli on cellulose acetate membrane filters. Microbios 7:235-240.
- Brusick, D.J. (1978) Automated plate counting assays in the Ames Salmonella/microsome mutagenicity test. Pharm. Technol. 2:37-40 and 65.
- Buchanan, R.E. and Gibbons, N.E. (editors) (1974) Bergey's Manual of Determinative Bacteriology. The Williams and Wilkins Co., Baltimore, 1246 pages.
- Bucharov, D.A. and Kulikovskii, A.V. (1971) Structural and biochemical changes of bacteria after the action of some chlorine containing preparation, Report 1. Tr. Vses. Nauchno Issled. Inst. Vet. Sanit. 38:165-1/0.
- Buck, J.D. (1975) Distribution of aquatic yeasts. Effect of incubation temperature and chloramphenicol concentration on isolation. Mycopathologia 56:73-79.
- Buck, J.D. (1978) Comparison of in situ and in vitro survival of Candida albicans in seawater. Micro. Ecol. 4:291-302.
- Buck, J.D. and Bubucis, P.M. (1978) Membrane filter procedure for enumeration of Candida albicans in natural waters. Appl. Environ. Microbiol. 35:237-242.
- Bundesen, H.N., Connolly, J.I., Rawlings, I.D., Gorman, A.E., McCoy, G.W. and Hardy, A.V. (1936) Epidemic amebic dysentery. National Inst. Health Bull. No. 166, 187 pages.

- Buras, N. (1976) Concentration of enteric viruses in wastewater and effluent: A two year survey. Water Research 10:295-298.
- Burke, J.A. (1975) Giardiasis in childhood. American Journal Dis. Child. 129:1304.
- Burleson, G.R. and Pollard, M. (1975) Inactivation of vegetative cells and spores of bacteria by ozone and sonication. Second Intl. Symposium on Ozone Technology (held in Montreal, Canada 1975), International Ozone Institute (now Association), pp. 445-454, Cleveland, Ohio.
- Burleson, G.R., Murray, T.M. and Pollard M. (1975) Inactivation of viruses and bacteria by ozone with and without sonication. Appl. Microbiol. 29:340-344.
- Burman, N.P. (1961) Some observations on coli-aerogenes bacteria and streptococci in water. J. Appl. Bact. 24:368-376.
- Burman, N.P. (1962) Bacteriological control of slow sand filtration. Effl. and Water Treatment J. 2:674-677.
- Burman, N.P. (1978) Slow sand filtration. H<sub>2</sub>O 11:348-351.
- Burman, N.P. and Colbourne, J.S. (1976) The effect of plumbing materials on water quality. J. Inst. Plumbing 3:12-13.
- Burman, N.P. and Colbourne, J.S. (1977) Techniques for the assessment of growth of microorganisms on plumbing materials used in contact with potable water supplies. Journal of Applied Bacteriology 43:137-144.
- Burman, N.P. and Colbourne, Jennifer S. (1979) Effect of nonmetallic materials on water quality. J. Inst. Wat. Engrs. Sci. 33:11-18.
- Burman, N.P., Stevens, J.K. and Evans, A.W. (1978) Streptococci as indicators in water supplies. In Streptococci, 335-347 Soc. Appl. Bact. Symposium Series No. 7, ed. F.A. Skinner and L.B. Quesnel. Academic Press, London.
- Butt, C.G. (1966) Primary amoebic meningoencephalitis. New England Journal of Medicine 274:1473-1476.

Conditions in water distribution cannot always be counted on to remain routine. Perturbations of the system may occur through: (1) necessary expansion of the distribution network because of growth of the community; (2) use of large volumes of water to fight fires; (3) natural or manmade disasters that disrupt the integrity of the network; and (4) errors by users, beyond the direct control of a water authority, that result in back-contamination of the water in public distribution. If appropriate designs and materials have been used in constructing a distribution system, water quality can be protected, in most instances, by properly organized maintenance and surveillance. However, regulations of users connected to the system, as well as the development of effective plans for dealing with emergencies, are important further aspects of operation.

#### Recommendations Concerning Storage and Distribution

1. Careful consideration must be given to the siting of service reservoirs.
2. Dead ends in pipes must be avoided and disused apparatus disconnected.
3. Distribution and plumbing systems should consist of materials that will not support microbial growth. New products should be tested for their ability to support microbial growth before they are accepted or rejected.
4. Regulations to prevent back-siphonage and cross-connections need enforcement.
5. Adequate disinfection procedures for the construction and repair of water mains are needed. Installers should be instructed to follow the installation codes, exactly.

Topic G discusses Technologic Problems in drinking water microbiology. A pervasive theme in drinking water microbiology is the avoidance, suppression, or destruction of microorganisms in water. As Topic G shows, some microorganisms have what might be regarded as a certain retaliatory capacity. Microorganisms have adapted to such a variety of aquatic environments outside of water systems that it is probably not surprising to find them so firmly entrenched in much of this manmade system as well. They may cause problems both in treatment and in distribution. Water

- Cady, P., Dufour, S.W., Shaw, J., and Kraeger, S.J. (1978) Electrical impedance measurements: Rapid method for detecting and monitoring microorganisms. J. Clin. Microbiol. 7:265-272.
- Cairns, J. Jr. (1977) Quantification of biological integrity. In The Integrity of Water (Edited by Ballentine, R.K., and Guarrain, L.J.) U.S. EPA, Office of Water and Hazardous Materials, Washington, D.C., pp. 171-187.
- Cairns, J.E., Nutt, S.G., and Afghan, B.K. (1979) Application of the ATP assay for monitoring the disinfection of wastewater streams. Proceedings of the International Symposium on Analytical Applications of Bioluminescence and Chemiluminescence. Brussels, 1978 (in press).
- Calabra, J.F., Cosenza, B.J. and Kolega, J.J. (1972) Recovery of gram-negative bacteria with hektoen agar. J. Water Poll. Cont. Fed. 44:491-493.
- Calkins, J., Buckles, J.D. and Moeller, J.R. (1976) The role of solar ultraviolet radiation in "natural" water purification. Photochem. Photobiol. 24:49-57.
- Callaghan, P. and Brodie, J. (1968) Laboratory investigation of sewer swabs following the Aberdeen typhoid outbreak of 1964. J. Hyg. 66:489-497.
- Carlson, S., Hasselbarth, U. and Langer, R. (1975) Abtötung aggregierter Keime bei der Wasserdesinfektion durch Chlor. Zbl. Bakt. Hyg. I Abt. Orig. B161:233-247.
- Carmichael, W.W. and Gorham, P.R. (1978) Anatoxins from clones of Anabaena flos-aquae isolated from lakes of Western Canada. Mitt. Internatl. Verein. Limnol. 21:285-295.
- Carrington, E.G. (in press) The fate of pathogenic microorganisms during wastewater treatment and disposal.
- Carson, L.A., Favero, M.S., Bond, W.W. and Petersen, N.J. (1972) Factors affecting comparative resistance of naturally occurring and subcultured Pseudomonas aeruginosa to disinfectants. Appl. Microbiol. 23:863-869.

- Carson, L.A., Petersen, N.J., Favero, M.S., Doto, L., Collins, P.E. and Levin, M.A. (1975) Factors influencing detection and enumeration of P. aeruginosa by most probable number and membrane filtration techniques. Applied Microbiol. 30:935-942.
- Caselitz, F.H. (1966) Pseudomonas-Aeromonas und ihre human-medizinische Bedeutung. Jena, Fisher Verlag.
- Cash, R.A., Music, S.I. and Libonati, J.P. (1974) Response of man to infection with Vibrio cholerae. I. Clinical and serologic and bacteriologic responses to a known inoculum. Journal Infect. Dis. 129:45-52.
- Center for Disease Control (1972) Morbidity and Mortality Weekly Rept. 21:290.
- Center for Disease Control (1975a) Yersinia enterocolitica infections -- Georgia, Utah. Morbidity and Mortality Weekly Report 24:147-148.
- Center for Disease Control (1975b) Viral hepatitis reporting. Morbidity and Mortality Weekly Report 24(19):165-166.
- Center for Disease Control (October 1, 1976a) Endemic giardiasis -- Northern Canada. Morbidity and Mortality Weekly Report 25:307.
- Center for Disease Control (1967b) Waterborne disease outbreaks, 1975. Foodborne and Waterborne Disease Outbreaks Annual Summary 1975, (CDC) 76-8185, pp. 55-58, U.S. Department of Health, Education and Welfare, Atlanta, Georgia.
- Center for Disease Control (1977a) Reported morbidity and mortality in the United States, 1976. Morbidity and Mortality Weekly Report Annual Summary 1976 25(53):2.
- Center for Disease Control (1977b) Waterborne disease outbreaks, 1976. Foodborne and Waterborne Disease Outbreaks Annual Summary 1976, (CDC) 78-8185, pp. 59-64, U.S. Department of Health, Education and Welfare, Atlanta, Georgia.
- Center for Disease Control (May 27, 1977c) Waterborne giardiasis outbreaks -- Washington, New Hampshire. Morbidity and Mortality Weekly Report 26:169 and 175.

- Center for Disease Control (May 19, 1978a) Intestinal parasite surveillance -- United States, 1976. Morbidity and Mortality Weekly Report 27:167-168.
- Center for Disease Control (June 23, 1978b) Waterborne Campylobacter gastroenteritis -- Vermont. Morbidity and Mortality Weekly Report 27:207.
- Center for Disease Control (October 13, 1978c) Vibrio cholerae infection -- Louisiana. Morbidity and Mortality Weekly Report 27:341-342 and 402.
- Center for Disease Control (1978d) Viral gastroenteritis -- Pennsylvania. Morbidity and Mortality Weekly Report 27(42):403-404.
- Center for Disease Control (November 10, 1978e) Legionnaires' Disease -- United States. Morbidity and Mortality Weekly Report 27:439-441.
- Cerkinsky, S.N., and Trahtman, N. (1972) The present status of research on the disinfection of drinking water in the U.S.S.R. Bull. World Health Organ. 46:277-283.
- Cerva, L. and Novak, K. (1968) Amoebic meningoencephalitis: Sixteen fatalities. Science 160:92.
- Chambers, C.W., Kabler, P.W., Malaney, G., and Bryant, A. (1952) Iodine as a bactericide. Soap and Sanit. Chem. 28:149-163.
- Chang, S.L. (1948) Some epidemiological and biological problems in waterborne amoebiasis. In Symposium on Limnol. Aspects of Water Supply and Waste Disposal, American Acad. for the Advancement of Sci. Proc., pp. 16-30.
- Chang, S.L. (1950) Kinetics in the thermodestruction of cysts of Endamoeba histolytica in water. American Journal of Hygiene 52:82-90.
- Chang, S.L. (1958) The use of active iodine as a water disinfectant. J. Am. Pharm. Assn. Sci. Ed. 48:417-423.
- Chang, S.L. (1968) Waterborne viral infections and their prevention. Bull. World Health Organ. 38:401-414.

- Chang, S.L. (1971a) Current Topics in Comparative Pathobiology, Vol. 1, pp. 201-254 (Edited by Cheng, T.C.) Academic Press, New York and London.
- Chang, S.L. (1971b) Modern Concept of disinfection. J. Sanit. Eng. Div., Am. Soc. Civ. Eng. SA5:689-707.
- Chang, S.L. (1978) Pathogenesis of pathogenic Naegleria amoeba. In Folia Parasitologica (Fourth International Congress of Parasitology, August 19-26, 1978) Warsaw, Poland.
- Chang, S.L., and Morris, J.C. (1953) Elemental iodine as a disinfectant for drinking water. Ind. and Eng. Chem. 45:1009-1012.
- Chang, S.L., Buckingham, M. and Taylor, M.P. (1948) Studies on Leptospira icterohaemorrhagiae; survival in water and sewage; destruction in water by halogen compounds, synthetic detergents and heat. Journal of Infectious Dis. 82:256-266.
- Chantereau, J. (1977) Corrosion bactérienne, Bactéries de la Corrosion. Technique et Documentation, Paris, 246 pages.
- Cherry, W.B., Hanks, J.B., Thomason, B.M., Murlin, A.M., Biddle, J.W. and Croom, J.M. (1972) Salmonellae as an index of pollution of surface water. Appl. Microbiol. 24:334-340.
- Chin, T.D.Y., Mosley, W.H., Robinson, A. and Gravelle, C.R. (1967) Detection of enteric viruses in sewage and water. Relative sensitivity of the method. In Transmission of Viruses by the Water Route, pp. 389-400 (Edited by Berg, G.) John Wiley and Sons, New York.
- Christensen, F. and Giese A.C. (1954) Changes in absorption spectra of nucleic acids and their derivatives following exposure to ozone and ultra violet radiation. Arch. Biochem. Biophys. 51:208-216.
- Clark, H.F., Geldreich, E.E., Jeter, H.L. and Kabler, P.W. (1951) The membrane filter in sanitary bacteriology. Public Health Reports 66:951-977, Washington, D.C.
- Clark, J.A. (1969) The detection of various bacteria indicative of water pollution by a presence-absence (P-A) procedure. Can. J. Microbiol. 15:771-780.

- Clark, J.A. and Vlassoff, L.T. (1973) Relationships among pollution indicator bacteria isolated from raw water and distribution systems by the presence-absence (P-A) test. Health Lab. Sci. 10:163-172.
- Clarke, N.A. and Chang, S.L. (1959) Enteric viruses in water. J. Am. Water Wks. Ass. 51:1299-1317.
- Clarke, N.A., Stevenson, R.E. and Kabler, P.W. (1956) The inactivation of purified type 3 adenovirus in water by chlorine. Am. J. Hyg. 64:314-319.
- Clarke, N.A., Berg, G., Kabler, P.W. and Chang, S.L. (1964) Human enteric viruses in water: Source, survival and removability. Adv. Water Pollut. Res. 2:523-541.
- Claudon, D.G., Thompson, D.I., Christenson, E.H., Lawton, G.W. and Dick, E.C. (1971) Prolonged Salmonella contamination of a recreational lake by runoff waters. Appl. Microbiol. 21:875-877.
- Clausen, E.M., Green, B.L. and Litsky, W. (1977) Fecal streptococci: Indicators of pollution. In Bacterial Indicators/Health Hazards Associated with Water ASTM STP 635:247-264 (Edited by Hoadley, A.W. and Dutka, B.J.) American Society for Testing and Materials, Philadelphia.
- Cleary, E.J. and Warner, D.L. (1970) Some considerations in underground wastewater disposal. Journal of the American Water Works Assoc. 62:489-498.
- Cohen, B. (1922) The effects of temperature and hydrogen ion concentration upon the viability of Bact. coli and Bact. typhosum in water. J. Bact., 7(2):183-230.
- Coin, L., Hannoun, C. and Gomella, C. (1964) Inactivation par l'ozone du virus de la poliomyélite présent dans les eaux. La Presse Medicale 72:2153-2156.
- Coin, L., Gomella, C., Hannoun, C. and Trimoreau, J.C. (1967) Inactivation par l'ozone du virus de la poliomyélite présent dans les eaux. La Presse Medicale 38:1883-1884.
- Colbourne, J.S. S. and Brown, D.A. (1979) Dissolved oxygen utilization as an indicator of total microbial activity on non-metallic materials in contact with potable water. Journal of Applied Bacteriology 47:223-231.



Colwell, R.R. and Kaper, J. (1977) Vibrio species as bacterial indicators of potential health hazards associated with water. In Bacterial Indicators/Health Hazards Associated with Water, pp. 115-25 (Edited by Hoadley, A.W. and Dutka, B.J.) STP 635 American Society for Testing and Materials, Philadelphia.

Colwell, R.R., Kaper, J. and Joseph, S.W. (1977) Vibrio cholerae, Vibrio parahaemolyticus, and other vibrios: Occurrence and distribution in Chesapeake Bay. Science 198:394-396.

Colwell, R.R., Austin, B. and Wan, L. (1978) Public health considerations of the microbiology of "potable" water. In Evaluation of the Microbiology Standards for Drinking Water (Edited by Hendricks, C.W.) EPA 570/9-78-00 C, Environmental Protection Agency, Washington, D.C.

Commission of the European Communities (1975) Council directive of May 16, 1975 concerning the quality of surface water intended for the abstraction of drinking water in the member states. Official Journal of the European Communities 194:26-31.

Commission of the European Communities (1977) Bacteriological analyses of drinking water, Lyons Technical Seminar 16 to 20 June 1975. Environment and Quality of Life, EUR 5694 e, Office for Official Publications of the European Communities, Luxembourg, 106 pages.

Commission of the European Communities (1978) Proposal to a council directive concerning measuring methods and frequency for sampling and analysis of parameters as to quality of surface water intended for abstraction of drinking water. Official Journal of the European Communities C-208, 1-11.

Commission of the European Communities (1979) Council directive of December 17, 1979 concerning protection of groundwater as to pollution caused by special dangerous chemical compounds. Official Journal of the European Communities.

Committee on Back-Siphonage in Water Installations (1974) Report of the Committee on Back-Siphonage in Water Installations. H.M. Stationery Office, London.

- Cooney, M.K., Hall, C.E. and Fox, J.P. (1972) The Seattle virus watch. III. Evaluation of isolation methods and summary of infections detected by virus isolations. Amer. Journal of Epidemiol. 96:286-305.
- Craig, C.E. and Faust, E.C. (1964) Clinical Parasitology, 7th Edition, Lea and Febiger, pp. 90-94, Philadelphia.
- Cramer, W.M., Kawata, K., and Kruse, C.W. (1976) Chlorination and iodination of poliovirus and f2. J. Water Poll. Control Fed. 48:61-76.
- Craun, G.F. (1976) Microbiology-Waterborne outbreaks. J. Water Pol. Control Fed. 48:1378-1397.
- Craun, G.F. (June 1977) Waterborne outbreaks. Journal of the Water Pollution Control Fed., Literature Review, pp. 1268-1279.
- Craun, G.F. (1978) Impact of the coliform standard on the transmission of disease. In Evaluation of the Microbiology Standards for Drinking Water, pp. 21-35 (Edited by Hendricks, C.W.) EPA 570/9-78-OOC, U.S. Environmental Protection Agency, Washington, D.C.
- Craun, G.F. (1979) Waterborne disease outbreaks in the United States. J. Env. Hlth. 41:259-265.
- Craun, G.F. and McCabe, L.J. (1973) Review of the causes of waterborne disease outbreaks. J. Am. Water Works Assoc. 65:74-83.
- Craun, G.F., McCabe, L.J. and Hughes, J.M. (1976) Waterborne disease outbreaks in the U.S. 1971-1974. J. Am. Water Works Assoc. 68:420-424.
- Cronier, S., Scarpino, P.V., and Zink, M.L. (1978) Chlorine dioxide destruction of viruses and bacteria in water. In Water Chlorination Environmental Impact and Health Effects, pp. 651-657, vol. 2 (Edited by Jolly, R.L., Gorchev, H., and Hamilton, D.H., Jr.) Ann Arbor Sci., Ann Arbor, Mich.
- Cullimore, D.R. and McCann, A.E. (1977) The identification, cultivation and control of iron bacteria in ground-water. In Aquatic Microbiology (Edited by Skinner, F.A. and Shewan, J.M.) Academic Press, London, New York, San Francisco, 369 pages.

- Cundell, A.M. and Mulcock, A.P. (1973) Microbiological deterioration of natural rubber pipe-joint rings. Mater und Organismen 8:165-175.
- Cvjetanovic, B., Grab, B. and Uemura, K. (1978) Dynamics of acute bacterial diseases. Epidemiological models and their application in public health. Bull. World Health Organ. 56 Suppl. no. 1, 143 pages.
- Dahi, E. (1977) Impact of ultrasonic disaggregation of microorganisms in ozone water sterilization methods. Unpublished paper presented at the 3rd World Ozone Congress (Paris, France, 1977), sponsored by the International Ozone Institute (now Association), Cleveland, Ohio.
- Daley, R. (in press) Direct epifluorescence enumeration of native aquatic bacteria: Uses, limitations and comparative accuracy. In J.W. Costerton and R. Colwell (eds.) Native Aquatic Bacteria -- Enumeration, Activity and Ecology, AST Publication.
- Daley, R.J. and Hobbie, J.E. (1975) Direct counts of aquatic bacteria by a modified epifluorescence technique. Limnol. and Oceanog. 20:875-882.
- Danielsson, D., Laurell, G., Nordbring, F. and Sandler, O. (1968) A membrane filter method for the demonstration of bacteria by the fluorescent antibody technique. Acta Path. et Microbial. Scandinav. 72:118-124.
- Daubner, I. (1972) Drittes kapitel. In Mikrobiologie des Wassers, pp. 53-104, Inst. f. Limnologie, Slowakischen Academie der Wissenschaften, Bratislava, 440 pages.
- Daubner, I. (1975) Changes in the properties of E. coli under the influences of water environments. Verh. Int. Ver. Limnol. 19:2650-2657.
- Davenport, C.V., Sparrow, E.B. and Gordon, R.C. (1976) Fecal indicator bacteria persistence under natural conditions in an ice-covered river. Appl. Environ. Microbiol. 32:527-536.
- Davis, E.M. and Gloyna, E.F. (1972) Bacterial die-off in ponds. J. Sanit. Eng. Div. Am. Soc. Civ. Engrs. 98:59-69.

- Dawe, L.L., and Penrose, W.R. (1978) "Bactericidal" property of seawater: Death or debilitation? Appl. Environ. Microbiol. 35:829-833.
- DeJonckheere, J. and van de Voorde, H. (1976) Difference in destruction of cysts of pathogenic and nonpathogenic Naegleria and Acanthamoeba by chlorine. Applied and Environmental Microbiol. 31:294-297.
- Deland, F.H., and Wagner, H.N. Jr. (1969) Early detection of bacterial growth with carbon-14-labelled glucose. Radiology 92:154-155.
- De Man, J.C., Rogosa, M. and Sharpe, M.E. (1960) A medium for the cultivation of Lactobacilli. J. Appl. Bact. 23 (1):130-135.
- De Mol, P., and Bosmans, E. (1978) Campylobacter enteritis in Central Africa. Lancet 1:604.
- Dennis, W.H. Jr., Olivieri, V.P. and Kruse, C.W. (1979) Mechanism of disinfection: Incorporation of Cl-36 into f<sub>2</sub> virus. Water Research 13:363-369.
- Derham, C.J. (1975) Physical properties of pipe sealing rings -- a comparison between natural and synthetic rubbers. Natural Rubber Technol. 6:41-51.
- Diaper, E.W.J. (1972) Practical aspects of water and wastewater treatment by ozone. In Ozone in Water and Wastewater Treatment (Edited by Evans, F.L.) Environ. Protection Agency, Cincinnati.
- Dickenson, P.B. (1965) Natural rubber and its use in underground pipe sealing rings. Rubber Dev. 18:85-90.
- Dickenson, P.B. (1969) Natural rubber and its traditional use in underground pipe sealing rings. J. Rubber Res. Inst., Malaya 22:165-175.
- Dillenberg, H.W. and Dehnel, M.K. (1960) Toxic waterbloom in Saskatchewan. Canadian Medical Assoc. Journal 83:1151-1154.
- DiLuzio, N.R. and Friedmann, T.J. (1973) Bacterial endotoxins in the environment. Nature 244:49-51.

- Dominowska, C. and Malottke, R. (1971) Survival of Yersinia in water samples originating from various sources. Bull. Inst. Mar. Med. Gdansk 22:173-182.
- Donnelly, C.B., Gilchrist, J.E., Peeler, J.T. and Campbell, J.E. (1976) Spiral plate count method for the examination of raw and pasteurized milk. Appl. Environ. Microbiol. 32:21-27.
- Dornedden, H. (1930) Beitrage zur Trinkwassereinigung durch die langsame sandfiltration. G.W.F. 73:319-325.
- Dougan, J. and Tan, L. (1973) Detection and quantitative measurement of fecal water pollution using a solid-injection gas chromatographic technique and fecal steroids as a chemical index. J. of Chromatogr. 86:107-116.
- Drake, C.H. (1966) Evaluation of culture media for the isolation and enumeration of Pseudomonas aeruginosa. Health Lab. Sci. 3(1):10-19.
- Drake, J.F. and Tsuchiya, H.M. (1976) Predation on Escherichia coli by Colpoda steinii. Appl. Environ. Microbiol. 31:870-874.
- Drasar, B.S. (1974) Some factors associated with geographical variations in the intestinal microflora. In Society for Applied Bacteriology Symposium Series No. 3. The Normal Microbial Flora of Man, pp. 187-196 (Edited by Skinner, F.A. and Carr, J.C.) Academic Press, London.
- Druce, R.G. and Thomas, S.B. (1970) An ecological study of the psychrotrophic bacteria of soil, water, grass, and hay. Journal of Applied Bacteriology 33:420-435.
- Dudly, R.H., Hekimian, K.K. and Mechalas, B.J. (1976) A scientific basis for determining recreational water quality criteria. J. Water Poll. Control Fed. 12: 2761-2777.
- Dufour, A.P. (1977) Escherichia coli: The fecal coliform. In Bacterial Indicators/Health Hazards Associated with Water, ASTM STP 635 (Edited by Hoadley, A.W. and Dutka, B.J.) American Society for Testing and Materials, Philadelphia, Pennsylvania.

- Dufour, A.P. and Cabelli, V.J. (1976) Characteristics of Klebsiella from textile finishing plant effluents. J. Water Pollution Control Fed. 48:872-879.
- Duncan, D.W. and Razzell, W.E. (1972) Klebsiella biotypes among coliforms isolated from forest environments and farm produce. Appl. Microbiol. 24:933-938.
- Dunn, C.C. (1952) Mechanism of action of some germicidal inhibitory agents. Am. Brewing 85:25-30.
- Dupont, H.L., Hornick, R.B. and Dankins, A.T. (1969) The response of man to virulent Shigella flexneri 2A. J. Infect. Dis. 119:296-299.
- Dupont, H.L., Hornick, R.B., Snyder, M.J., Libonati, J.P. and Formal, S.B. (1972) Immunity in shigellosis. II. Protection induced by oral live vaccine or primary infection. J. Infect Dis. 125:12-16.
- Dutka, B.J. (1973) Coliforms are an Inadequate Index of Water Quality. J. Environ. Health 36:39-46.
- Dutka, B.J., Chau, A.S.Y. and Coburn, J. (1974) Relationship between bacterial indicators of water pollution and fecal sterols. Water Res. 8:1047-1055.
- Dykes, A.C., Schultz, M.G. and Juranek, D.D. (1977) Outbreak of suspected waterborne giardiasis in the state of Washington. Public Health Service-CDC-Phoenix, EPI 76-82-3.
- Dykes, D.R., Bry, T.S., and Kline, C.H. (1967) Water Management. Env. Science & Tech. 1:780-784.
- Eijkman, C. (1904) Die Garungsprobe bei 46 als Hilfsmittel bei der Trinkwasseruntersuchung. Zentralblatt für Bakteriologie, Abth. I. Orig. 37:742.
- Engelbrecht, R.S. and Greening, E.O. (1978) Chlorine-resistant indicators, 243-266. In Indicators of Viruses in Water (Edited by Berg, G.) Ann Arbor Science Publisher, Inc., Ann Arbor, Mich., 424 pages.
- Engelbrecht, R.S., Severin, B.F., Masarik, M.T., Farooq, S., Lee, S.H., Haas, C.N. and Lalchandani, A. (1977) New microbial indicators of disinfection efficiency. EPA-600/2-77-052, U.S. Environmental Protection Agency, Cincinnati.

- Engelbrecht, R.S., Weber, M.J., Schmidt, C.A. and Salter, B.L. (1978) Virus sensitivity to chlorine disinfection of water supplies. Final Report, EPA-600/2-78-123, 43 pages.
- Environmental Protection Agency (Wed., Dec. 24, 1975) Water Programs -- National Interim Primary Drinking Water Regulations, Part IV, Federal Register 40(248):59566-59588.
- Environmental Protection Agency (1978) Human Viruses in the Aquatic Environment: A Status Report With Emphasis on the EPA Research Program, EPA 570/9-78-006, Environmental Research Center, Cincinnati, Ohio.
- Esposito, P., Scarpino, P.V., Chang, S.L. and Berg, G. (1974) Destruction by dichloramine of viruses and bacteria in water. Abstract G-99. Abstracts of the annual meeting, Am. Soc. for Microbiol., Washington, D.C.
- Evans, D.M. and Levisohn, I. (1968) Biodeterioration of polyester-based polyurethanes. Int. Biodeterior. Bull. 4:89-92.
- Evans, T.M., Shillinger, J.E., and Stuart, D.G. (1978) Rapid determination of bacteriological water quality by using *Limulus* lysate. Appl. Environ. Microbiol. 35:376-382.
- Evison, L. (1977) Disinfection of water with ozone: Comparative studies with enteroviruses, phage and bacteria. Unpublished paper presented at the 3rd World Ozone Congress (Paris, France, 1977), sponsored by the International Ozone Institute (now Association), Cleveland, Ohio.
- Evison, L.M. and James, A. (1975) Bifidobacterium as an indicator of faecal pollution in water. Prog. Wat. Tech. 7(2):57-66.
- Evison, L.M. and Morgan, S. (1978) Further studies on Bifidobacteria as indicators of faecal pollution in water. Prog. Wat. Tech. 10(5/6):346-350.
- Eyssen, H.J., Parmentier, G.G., Compennolle, F.C., DePauw, G. and Pressens-Denef, M. (1973) Biohydrogenation of sterols by *Eubacterium* ATCC 21408 -- Nova Species. Env. J. Biochem. 36:411-421.

- Fair, G.M., Geyer, J.C., and Okun, D.A. (1968) Water and Wastewater Engineering, Vol. 2, pp. 31/1-31/29, John Wiley and Sons Publishers, New York.
- Fair, J.F. and Morrison, S.M. (1967) Recovery of bacterial pathogens from high quality surface waters. Water Resour. 3:799-803.
- Farooq, S. (1976) Kinetics of inactivation of yeasts and acid-fast organisms with ozone. Thesis of doctorate University of Illinois at Urbana-Champaign (Report Number 76-24,077).
- Farooq, S., Engelbrecht, R.S. and Chian, E.S.K. (1977) The effect of ozone bubbles on disinfection. Prog. Water Technol. 9:157-166.
- Farooq, S., Chian, E.S.K. and Engelbrecht, R.S. (1977a) Basic concepts in disinfection with ozone. J. Water Pollution Control Fed. 49:1818-1831.
- Farooq, S., Engelbrecht, R.S. and Chian, E.S.K. (1977b) Influence of temperature and UV light on disinfection with ozone. Water Res. 11:737-741.
- Fattal, B. and Nishmi, M. (1977) Enterovirus types in Israel sewage. Water Research 11:393-396.
- Feachem, R.G. (1977) Infectious disease related to water supply and excreta disposal facilities. Ambio. 6:55-58.
- Feachem, R.G., Bradley, D.G., Garelick, H., and Mara, D.D. (1978). Health aspects of Excreta and Wastewater Management. The World Bank, Washington, D.C.
- Federal Ministry of Health (1969) Evaluation and treatment of accidents with mineral oil in the country under the aspects of water protection. Water and Mineral Oil Work Group, Federal Ministry of Health, Bad Godesberg, 138 pages.
- Federal Ministry of the Interior (1975) Bank filtration. Report of the Federal Ministry of the Interior. Committee on Water Supply and Bank Filtrate. Committee of Water Maintenance and Bank Filtration, Bonn, 182 pages.
- Felsenfeld, O. (1967) The Cholera Problem. Warren H. Green, Inc., St. Louis, Missouri, 165 pages.
- Feng, T.H. (1966) Behavior of organic chloramines in disinfection. J. Water Poll. Control Fed. 38:614-628.



- Fennell, H., James, D.B. and Morris, J. (1974) Pollution of a storage reservoir by roosting gulls. J. Soc. Wat. Treat. Exam. 23(1):5-24.
- Fetner, R.H. (1962) Chromosome breakage in Vicia faba by monochloramine. Nature 196:1122-1123.
- Fetner, R.H. and Ingols, R.S. (1956) A comparison of the bactericidal activity of ozone and chlorine against Escherichia coli at 1°C. J. Gen. Microbiol. 15:381-385.
- Finkelstein, R.A. (1973) Cholera. CRC Critical Reviews in Microbiol. 2:553-623.
- Fjordingstad, E. (1956) Bacteriological investigations of mine water from lignite pits in Denmark. Schweitz, Z. Hydrobiol. 18:215-238.
- Fjordingstad, E. (1969) Bacteriological corrosion of concrete in water. Water Research 3:21-30.
- Flewett, T.H., Bryden, A.S. and Davies, H. (1975) Epidemic viral enteritis in a long-stay children's ward. Lancet (i):4-5.
- Fliermans, C.B. and Schmidt, E.L. (1975) Fluorescence microscopy: Direct detection, enumeration and spatial distribution of bacteria in aquatic systems. Arch. Hydrobiol. 76:33-42.
- Floyd, R. and Sharp, D.G. (1977) Aggregation of polio- and reovirus by dilution in water. Appl. Environ. Microbiol. 33:159-167.
- Floyd, R. and Sharp, D.G. (1978) Viral aggregation: Effects of salt on the aggregation of poliovirus and reovirus at low pH. Appl. Environ. Microbiol. 35:1084-1094.
- Fluegge, R.A., Metcalf, T.G. and Wallis, C. (1979) Virus inactivation in wastewater effluents by chlorine, ozone and ultraviolet light. Prog. in Wastewater Disinfection Technology, U.S. Environmental Protect. Agency, Office of Research and Development, EPA 600/9-79-018, pp. 223-232.

- Foliguet, J.M., Lavillaureix, P. and Schwartzbrod, L. (1973) Virus et eaux II. Mise en evidence des virus dans le milieu hydrique. Rev. Epidem. Med. Soc. et Santé Publique 21:185-259.
- Fowler, M.C. and Carter, R.F. (1965) Acute pyogenic meningitis probably due to Acanthamoeba species: A preliminary report. British Medical Journal 2:740-742.
- Fruin, J.T. and Clark, W.S. (1977) Plate count accuracy: Analysts and automatic colony counter versus a true count. J. Food Prot. 40:552-554.
- Fuchs, G.H.P. and Burger, G. (1974) Standardisierungsprobleme bei serodiagnostischen Leptospirose-Untersuchungen. Zbl. Bakt. Hyg., I. Abt. Orig. A. 228:378-387.
- Gall, R. (1978) Chlorine dioxide. An overview of its preparation, properties and uses. In Ozone/Chlorine Dioxide Oxidation Products of Organic Materials pp. 356-382 (Edited by Rice, R.G. and Cotruvo, J.A.) International Ozone Institute, Inc., Cleveland, Ohio.
- Gallagher, T.P. (1965) Public Health Service Report on pollution of interstate waters of the Red River of the North (Minnesota, North Dakota), Robert A. Taft Sanitary Eng. Ctr., Cincinnati, Ohio, 175 pages.
- Gameson, A.L.H. and Saxon, J.R. (1967) Field studies on effect of daylight on mortality of coliform bacteria. Water Res. 1, pp. 279-295.
- Geldreich, E.E. (1970) Applying bacteriological parameters to recreational water quality. Journal of the American Water Works Association 62:113-120.
- Geldreich, E.E. (1972) Waterborne pathogens. In Water Pollution Microbiology, pp. 207-241 (Edited by Mitchell, R.) John Wiley and Sons, New York.
- Geldreich, E.E. (1975) Handbook for Evaluating Water Bacteriological Laboratories pp. 1-195. EPA-670/9-75-006, U.S. Environmental Protection Agency, Cincinnati, Ohio.
- Geldreich, E.E. (1978) Bacterial populations and indicator concepts in feces, sewage, stormwater and solid wastes. In Indicators of Viruses in Water and Food, pp. 51-98 (Edited by Berg, G.) Ann Arbor Science, Ann Arbor.

- Geldreich, E.E. and Clarke, N.A. (1966) Bacterial pollution indicators in the intestinal tract of freshwater fish. Appl. Microbiol. 14:429-437.
- Geldreich, E.E. and Kenner, B.A. (1969) Concepts of fecal streptococci in stream pollution. Journal of the Water Pollution Control Federation 41:R336-352.
- Geldreich, E.E., Clark, H.F., Kabler, P.W., Huff, C.B. and Bordner, R.H. (1958) The coliform group. II. Reaction in EC medium at 45°C. Applied Microbiology 6:347-348.
- Geldreich, E.E., Kenner, B.A. and Kabler, P.W. (1964) Occurrence of coliforms, fecal coliforms, and streptococci on vegetation and insects. Appl. Microbiol. 12:63-69.
- Geldreich, E.E., Nash, N.D., Reasoner, D.J. and Taylor, R.H. (1972) The necessity for controlling bacterial populations in potable water: Community water supply. J. American Water Works Assoc. 64:596-602.
- Geldreich, E.E., Nash, H.D., Reasoner, D.J. and Taylor, R.H. (1975) The necessity of controlling bacterial populations in potable waters: Bottle water and emergency water supplies. J. Am. Water Works Ass. 67:117-124.
- Gelfand, H.M., Fox, J.P. and Leblanc, D.R. (1957) The enteric viral flora of a population of normal children in Southern Louisiana. Amer. Journal of Trop. Med. Hygiene 6:521.
- Gellman, I. (1975) Further studies of the sanitary significance of Klebsella pneumoniae occurrence in mill effluents and surface waters. Tech. Bull. 279. National Council of the Paper Industry for Air and Stream Improvement, Inc., New York.
- Gentile, J.H. and Maloney, T.F. (1969) Toxicity and environmental requirements of a strain of Aphanizomenon flos-aquae (L.) Ralfs. Canadian Journal of Microbiology 15:165-173.
- Gerba, C.P., Wallis, C. and Melnick, J.L. (1975a) Viruses in water: The problem, some solutions. Environmental Science and Technol. 9:1122-1126.

- Gerba, C.P., Wallis, C. and Melnick, J.L. (1975b) Fate of wastewater bacteria and viruses in soil. Journal of the Irrigation and Drainage Div., Proceedings of the American Society of Civil Engineers, 101, IR 3:145-155.
- Gevaudan, P., Bossy, G., Gulian, C. and Sanchez, Y. (1971) Action de l'ozone sur le virus de la poliomyelite present dans l'eau. Terres et Eaux 67:25-28.
- Ghan, H.B., Chen, C.L. and Miele, R.P. (1976) The significance of water quality on wastewater disinfection with ozone. Forum on Ozone Disinfection, Proc. of a forum held in Chicago, Ill., 1976 (Edited by Fichtman, E.G., Rice, R.G. and Browning, M.E.) International Ozone Institute (now Association), Cleveland, Ohio, pp. 46-65.
- Gilchrist, J.E., Campbell, J.E., Donnelly, C.B., Peeler, J.T. and Delaney, J.M. (1973) Spiral plate method for bacterial determination. Appl. Microbiol. 25:244-255.
- Gilcreas, F.W. and Kelly, S.M. (1955) Relation of coliform-organism test to enteric-virus pollution, J. Am. Water Works Assoc. 47:683-694.
- Gilfillan, D.J. (1971) Report on the investigation of back-siphonage risks in domestic properties, Winter 1970/71. Report T.P. 82, Water Research Association, Medmenham, England.
- Glathe, H. and Ottow, J.C.G. (1972) "Ökologische und physiologische Aspekte zum Mechanismus der Eisenoxydation und Ockerbildung -- Eine Übersicht." Zbl. Bakt. II. Abt. 127:749-769.
- Godlewska-Lipowa, W.A. and Jablonska, I. (1972) Spatial differentiation abundance of bacteria in the water of Mikolajskie lakes. Ekologia Polska 20:367-371.
- Goethe, H., Zorn, E. and Müller, G. (1969) Hygienische Probleme der Trinkwasserversorgung an Bord von Schiffen unter Besonderer Berücksichtigung von Vakuumverdampferanlagen und Ultraviolettwasserentkeimung. Stadtehygiene 20:1-3.
- Goldschmid, J., Zohar, D., Argaman, Y. and Kott, Y. (1973) Effect of dissolved salts on the filtration of coliform bacteria in sand dunes. In Advances in Water Pollution Research, pp. 147-157 (Edited by Jenkins S.H.) Pergamon, Oxford, U.K.

- Goldstein, B.D. and McDonagh, E.H. (1975) Effect of ozone on cell membrane protein fluorescence. I. In vitro studies utilizing the red cell membrane. Environ. Res. 9:179-186.
- Gorham, P.R. (1962) Laboratory studies on the toxins produced by waterblooms of blue-green algae. American Journal of Public Health 52:2100-2105.
- Gorham, P.R. (1965) Toxic waterblooms of blue-green algae. In Transactions of the Third Seminar on Biological Problems in Water Pollution (August 13-17, 1962) U.S. Public Health Service Bulletin 999-WP-25, pp. 37-44, Cincinnati, Ohio.
- Goss, W.A., Michaud, R.N. and McGrath, M.B. (1974) Evaluation of an automated colony counter. Appl. Microbiol. 27:1:264-267.
- Gotovskaia, S.N. and Mogaram, M.E. (1945) Study of the bactericidal action of chlorine on B. tularensis in drinking water. Zh. Mikrobiol. 7(8):50-55.
- Gould, R.G. and Cook, R.P. (1958) The metabolism of cholesterol and other sterols in the animal organism. In Cholesterol, Chemistry, Biochemistry and Pathology (Edited by Cook, R.P.) pp. 289-292, Academic Press, New York.
- Goyal, S.M., Gerba, C.P. and Melnick, J.L. (1978) Prevalence of human enteric viruses in coastal canal communities. Journal of the Water Pollution Control Fed. 50:2247-2256.
- Granstrom, M.L. and Lee, G.F. (1958) Generation and use of chlorine dioxide in water treatment. J. Am. Water Works Assoc. 50:1453-1466.
- Graveland, A. and Hrubec, J. (1976) Technieken voor de bereiding van drinkwater. In Gezond drinkwater (Editor Samenstelling) B.C.J. Zoeteman, Staatsuitgeverij 's-Gravenhage, the Netherlands.
- Graves, I.L. and Oppenheimer, J.R. (1975) Human viruses in animals in West Bengal: An ecological analysis. Human Ecology 3:105-130.

- Green, D.E. and Stumpf, P.K. (1946) The mode of action of chlorine. J. Am. Water Works Ass. 38:1301-1305.
- Grew, N., Gohd, R.S., Arguedas, J. and Kato, J.I. (1970) Enteroviruses in rural families and their domestic animals. Amer. Journal of Epidemiol. 96:518-526.
- Guelin, A., Lepine, P. and Lamblin, D. (1967) Pouvoir bactericide des eaux polluees et role de Bdellovibrio bacteriovorus. Ann. Inst. Pasteur. 113:660-665.
- Guy, M.D., McIver, J.D. and Lewis, M.J. (1977) The removal of virus by a pilot treatment plant. Water Res. 11: 421-428.
- Gyllenberg, H. and Niemela, S. (1959) A selective method for the demonstration of bifidobacteria (Lactobacillus bifidus) in materials tested for faecal contamination. Maataloustieteellinen Aikakauskirja. 31:94-97.
- Hadley, W.K. and Senyk, G. (1975) Early detection of microbial metabolism and growth by measurement of electrical impedance. Microbiology 1975 (Edited by Schlessinger, D.) pp. 12-21, American Society for Microbiology, Washington, D.C.
- Hajna, A.A. and Perry, A.C. (1943) Comparative study of presumptive and confirmative media for bacteria of coliform group and for fecal streptococci. American Journal of Public Health 33:550-556.
- Hamelin, C. and Chung, Y.S. (1974) Résistance à l'ozone chez Escherichia coli. II. Relations avec certains mécanismes de réparation de l'ADN. Molec. Gen. Genet. 129:177-184.
- Hamelin, C. and Chung, Y.S. (1975) The effect of low concentrations of ozone on Escherichia coli chromosome. Mutation Res. Netherl. 28:131-132.
- Hamilton, R.D. and Holm-Hansen, O. (1967) Adenosine triphosphate content of marine bacteria. Limnol., Oceanog. 12:319-324.
- Hanes, N.B. Sarles, W.B. and Rohlich, G.A. (1964) Dissolved oxygen and survival of coliform organisms and enterococci. J. Am. Water Works Assoc. 56:441-446.

- Hanson, P.G., Standridge, J., Jarrett, F. and Maki, D.G. (1977) Freshwater wound infection due to Aeromonas hydrophila. Journal of the American Medical Assoc. 238:1053-1054.
- Hardy, A.V. and Spector, B.K. (1935) The occurrence of infestation with Endamoeba histolytica associated with waterborne epidemic diseases. Public Health Report 50:323-329.
- Harris, R.H. and Mitchell, R. (1975) Inhibition of flocculation of bacteria by biopolymers. Water Research 9:993-999.
- Harvey, R.W.S., Price, T.H., Foster, D.W. and Griffiths, W.C. (1969) Salmonellas in sewage. A study in latent human infections. J. Hyg. (Brit.) 67:517-523.
- Harvey, S., Greenwood, J.R., Pickett, M.J. and Mah, R.A. (1976) Recovery of Yersinia enterocolitica from streams and lakes of California. Appl. Environ. Microbiol. 32:352-354.
- Haufele, A. and Sprockhoff, H.V. (1973) Ozon als Desinfektionsmittel gegen vegetative Bakterien, Bazillensporen, Pilze und Viren in Wasser. Zbl. Bakt. Hyg., I Abt. Orig. B. 157:53-70.
- Hayashi, M., Suzuki, T. and Saito, H. (1975) An investigation of drinking water on ships. Yokohama-shi Eisei Kenkyusho Nempo 15:35-38.
- Heath, C.W., Alexander, A.D. and Galton, M.M. (1965) Leptospirosis in the United States. Analysis of 483 cases in man, 1949-1961. New England Journal of Medicine 273:915-922.
- Heathman, L.S., Pierce, S.O., and Kabler, P.W. (1936) Resistance of Various Strains of S. typhi and Coli-Aerogenes to Chlorine and Chloramine. Publ. Health Rpts. 51:1367.
- Hegner, R. (1930) Host-parasite specificity in the genus Giardia. In Problems and Methods of Research in Protozoology (Edited by Hegner, R. and Andrews, A.J.) MacMillan, New York.

- Heiberg, B. (1935) On the classification of Vibrio cholerae and the cholera-like vibrios. A. Buschk, Kopenhagen, 181 pages.
- Hem, J.D. (1963-1965) Chemical equilibria and rates of manganese oxidation. Geological Survey Water Supply Paper, pp. 1667 A-D, U.S. Government Printing Office, Washington, D.C.
- Henderson, J.M. (1968) Enteric disease criteria for recreational waters. J. of Sanitary Eng. Div., Amer. Soc. Civil Eng. 94:1253-1276.
- Hendricks, C.W. (1978) Exceptions to the coliforms and the fecal coliform tests. In Indicators of Viruses in Water and Food, pp. 99-145 (Edited by Berg, G.) Ann Arbor Science, Ann Arbor.
- Hettche, O. and Schulz-Ehlbeck, H.W. (1953) Epidemiology and prophylaxis of polymyelitis with respect to the role of water in its transmission. Arch. Hyg. Bakt. 137:440-449.
- Highsmith, A.K., K., Feeley, J.C., Skaliy, P, Wells, J.C., and Wood, T. (1977a) Isolation of Yersinia enterocolitica from well water and growth in distilled water. Appl. Env. Microbiol. 34:745-750.
- Highsmith, A.K., Feeley, J.C. and Morris, G.K. (1977b) Isolation of Yersinia enterocolitica from water. In Bacterial Indicators/Health Hazards Associated with Water, pp. 265-274 (Edited by Hoadley, A.W. and Dutka, B.J.) ASTM STP 635, Amer. Society for Testing and Materials, Philadelphia.
- Hills, D.A. (1967) The degradation of natural rubber pipe-joint rings. Rubber J. 149:12-17.
- Hirn, J. and Raevuori, M. (1978) Tryptose-sulfite-cycloserine-egg yolk agar, membrane filter method for the detection of Cl. perfringens in Water. Water Research 12:451-454.
- Hoadley, A.W. (1977) Potential health hazards associated with Pseudomonas aeruginosa. In Bacterial Indicators/Health Hazards Associated with Water, pp. 80-114 (Edited by Hoadley, A.W. and Dutka, D.J.) American Society for Testing and Materials, Philadelphia, 356 pages.



- Hoadley, A.W. and Cheng, C.M. (1974) The recovery of indicator bacteria on selective media. J. Appl. Bacteriol. 37:45-57.
- Hoadley, A.W. and Dutka, B.J. (Editors) (1977) Bacterial Indicators/Health Hazards Associated with Water, ASTM STP 635, American Society for Testing and Materials, Philadelphia.
- Hobbie, J.E., Daley, R.J., and Jasper, S. (1977) Use of Nucleopore filters for counting bacteria by fluorescence microscopy. Appl. Environ. Microbiol. 33:1225-1228.
- Hoehn, R.C., Randall, C.W., Bell, F.A., Jr. and Shaffer, P.T.B. (1977) Trihalomethanes and viruses in water supply. Journal of Environmental Engineering Div. ASCE 103:803-814.
- Hoekstra, A.C. (1978) Desinfectie van Haags drinkwater en zuiverende werking van de langzame zandfilter, periode 1966-1978. Report of DWL's-Gravenhage, 5 pages. Drinkwaterleiding van 's-Gravenhage, 's-Gravenhage, The Netherlands.
- Hoff, J.C. (1978) The relationship of turbidity to disinfection of potable water. In Evaluation of the Microbiology Standards for Drinking Water (Edited by Hendriks, C.W.) EPA-570/9-78-00C, U.S. EPA, Washington, D.C., 235 pages.
- Hoffman, A. (1970) Studies on the suitability of coprostanol as an indicator of fecal pollution in water. University of Massachusetts. Ph.D. Thesis.
- Holden, W.S. (Editor) (1970) Water Treatment and Examination, pp. 197, 254, 248, and 330. Churchill, London.
- Hollister, A.C., Jr., Beck, M.D., Gittelsohn, A.M. and Hemphill, E.C. (1955) Influence of water availability on Shigella prevalence in children of farm labor families. American Journal of Public Health 45:354-362.
- Holluta, J. and Unger, U. (1954) Die Keimtotung von Bact. E. coli durch Chlordioxyd und Ozon. Vom Wasser 21:129-142.

- Holm-Hansen, O. and Booth, C.R. (1966) The measurement of Adenosine triphosphate in the ocean and its ecological significance. Limnol., Oceanog. 11:510-519.
- Hopla, C.E. (1974) The ecology of tularemia. In Advances in Veterinary Science and Comparative Medicine, pp. 25-53 (Edited by Brandly, C.A. and Cornelius, C.E.) Academic Press, New York and London.
- Hoppe, H.G. (1976) Determination and properties of actively metabolizing heterotrophic bacteria in the sea, investigated by means of micro-autoradiography. Marine Biology (Berlin) 36:291-302.
- Hoppe, R.C. (1976) Determination and properties of actively metabolizing heterotrophic bacteria in the sea, investigated by means of microautoradiography. Marine Biol. 36:291-302.
- Hornick, R.B., Greisman, S.E. and Woodward, T.E. (1970) Typhoid fever: Pathogenesis and immunologic control. New England J. Med. 283:686-691.
- Horsfall, F.L. and Tamm, I. (Editors) (1965) Viral and Rickettsial Infections of Man, p. 574, Lippincott, Philadelphia.
- Horster, L. (1943) Die bedeutung der ambenruhr fur Nord-dafrika und ihre Bekampfung. Deut. Tropenmed. Ztschr. 47:299-305.
- Horwitz, M.A., Hughs, J.M. and Craun, G.C. (1976) Outbreaks of waterborne diseases in the United States, 1974. Journal of Infectious Dis. 135:588-593.
- Houston, A.C. (1908 to 1911) First through Seventh Reports on Research Work, Metropolitan Water Board, Thames Water Authority, London.
- Houston, A. (1916) The Growth of Microbes on Leather Washers. 12th Research Report, Metropolitan Water Board, London.
- Hsu, Y. (1964) Resistance of infectious RNA and transforming DNA to iodine which inactivates f2 phage and cells. Nature 203:152.
- Hsu, Y., Shigeko, N. and Kruse, C.W. (1965) Some bactericidal and virucidal properties of iodine not affecting infectious RNA and DNA. Am. J. Epidemiol. 82:317-328.

- Hugh, R. and Gilardi, G.L. (1974) Pseudomonas. In Manual of Clinical Microbiology, Second Edition, pp. 250-269 (Edited by Lennette, E.H., Spaulding, E.H. and Truant, J.P.) American Society for Microbiology, Washington, D.C.
- Hughes, J.M. and Merson, M.H. (1975) Outbreaks of water-borne disease in the U.S., 1973. Journal of Infectious Diseases 132:336-339.
- Hugues, B. and Plissier, M. (1977) Inactivation comparée de poliovirus 1, Escherichia coli, Salmonella paratyphi B par le chlore et par l'ozone. Convention de recherche No. 74-47 avec le Ministère de la Qualité de la Vie et de l'Environnement Operation No. 5600 74-069.
- Huisman, L. and Wood, W.E. (1974) Slow sand filtration. World Health Organization, Geneva.
- Hunter, C.A. and Ensign, P.R. (1947) An epidemic of diarrhea in a newborn nursery caused by Pseudomonas aeruginosa. Amer. Journal of Public Health 37:1166-1169.
- Hutchinson, M. and Ridgway, J.W. (1977) Microbiological aspects of drinking water supplies. In Aquatic Microbiology. Society for Applied Microbiology, Symposium Series No. 6 (Edited by Skinner, F.A. and Shewan, J.M.) pp. 179-218, Academic Press, London.
- Hutchinson, M., Ridgway, J.W. and Cross, T. (1975) Bio-deterioration of rubber in contact with water, sewage and soil. In Microbial Aspects of the Deterioration of Materials. Society for Applied Bacteriology, Technical Series No. 9 (Edited by Lovelock, D.W. and Gilbert, R.J.) p. 261, Academic Press, London.
- Hvid, N. (1955) Microbiological and hygienic studies on underground water in Sjaelland. Thesis. Danish Science Press Ltd., Copenhagen, 194 pages.
- Ilvovitch, M. (1977) World water resources present and future. Ambio. 6:13-21.
- Ingols, R.S. and Ridenour, G.M. (1948) Chemical properties of chlorine dioxide in water treatment. J. Am. Water Works Assoc. 40:1207-1227.
- International Ozone Institute (now Association) (1976) Ozone News 1:1-6.

Internationaler Schiffsicherheitsvertrag (Solas) 60, Kap. 3, Regel 11, Abs. A (XIII, XVII) International Treaty for Safety on Ships.

Iversen, W.P. (1975) Anaerobic corrosion: Metals and microbes in two worlds. Dev. Ind. Microbiol. 16:1-10.

Jakubowski, W., Hoff, J.C., Anthony, N.C. and Hill, W.F., Jr. (1974) Epoxy fiberglass adsorbent for concentrating viruses from large volumes of potable water. Applied Microbiol. 28:501-502.

Jenkins, S.H. and Mendia, L. (Editors) (1967) Advances in Water Pollution Research, Water Pollution Control Fed., Washington, D.C., 421 pages.

Jepsen, A. (1972) Jord/Vand Hygiejne. A/S Carl Fr. Mortensen, Copenhagen, 223 pages.

Joklik, W.K. and Willett, H.P. (Editors) (1976) Zinsser Microbiology, Appleton-Century-Crofts, New York, 1223 pages.

Jones, E.B.G. and Campion-Alsumard, T. Le (1970). The biodeterioration of polyurethane by marine fungi, Int. Biodeterior. Bull. 6:119-124.

Jones, F., Smith, P. and Watson, D.C. (1978) Pollution of a water supply catchment by breeding gulls and the potential environmental health implications. J. Inst. Wat. Engrs. Sci. 32:469-482.

Jones, J. and Schmitt, J.A. (1978) The effect of chlorination on the survival of cells of Candida albicans. Mycologia 70:684-689.

Jones, J.G. (1974) Some observations on direct counts of freshwater bacteria obtained with a fluorescence microscope. Limnol. Oceanogr. 19:540-543.

Jordan, E.O., Russell, H.L. and Zeit, F.R. (1904) The longevity of the typhoid bacillus in water. Journal of Infectious Dis. 1:641-689.

Jorgensen, J.H., Lee, J.C., and Pahren, H.R. (1976) Rapid detection of bacterial endotoxins in drinking water and renovated wastewater. Appl. Environ. Microbiol. 32:347-351.

- Kampelmacher, E.H. and van Noorle Jansen, L.M. (1973) Salmonella and thermo-tolerant E. coli in the Rhine and Meuse at their points of entry into the Netherlands. Water 6:199-200.
- Kampelmacher, E.H. and van Noorle Jansen, L.M. (1976) Salmonella effluent from sewage treatment plants, wastepipe of butcher's shops and surface water in Walcheren. Zentralbl. Bakteriolog. Hyg. Abt. I, orig. B. 167:307-319.
- Kaneko, T. and Colwell, R.R. (1978) The annual cycle of Vibrio parahaemolyticus in Chesapeake Bay. Microbiol. Ecol. 4:135-155.
- Kaper, J., Lockman, H., Colwell, R.R. and Joseph, S.W. (1979) Ecology, serology, and enterotoxin production of Vibrio cholerae in Chesapeake Bay. Applied & Environ. Microbiol. 37:91-103.
- Kapikian, A.S., Wyatt, R.G., Dolin, R., Thornhill, T.S., Kalica, A.R. and Chanock, R.M. (1972) Visualization by immune electron microscopy of a 27-nm particle associated with acute infectious nonbacterial gastroenteritis. J. Virology 10:1075-1081.
- Kapperud, G. (1977) Yersinia enterocolitica and Yersinia-like microbes isolated from mammals and water in Norway and Denmark. Acta path. microbiol. scand. Sect. B, 85:129-135.
- Kapperud, G. and Jonsson, B. (1976) Yersinia enterocolitica in brown trout (Salmo trutta L.) from Norway. Acta path. microbiol. scand. Sect. B, 84:66-68.
- Kaschkin, P.N. (1974) Some aspects of the candidosis problem. Mycopathol. Mycol. Appl. 53:173-181.
- Kathe, J. (1945) Witterungsverhältnisse und Mäuse in ihrer Bedeutung für die Epidemiologie des Schlamm- und Feldfiebers. Zbl. Bakt., I. Abt. Orig. 151:481-489.
- Katz, D.H., Faulkner, M., Katz, L.R., Lindh, E., Leonhardt, C.C., Herr, K. and Tung, A.S. (1977) A rapid, semi-automated counting procedure for enumeration of antibody-forming cells in gel and nucleated cells in suspension. J. Immunol. Meth. 17:285-292.

- Katz, J. (1972) Experimentation With Human Beings, Russel Sage Foundation, New York, NY.
- Katzenelson, E. (1967) A rapid method for quantitative assay of poliovirus from water with the aid of fluorescent antibody technique. Archives of Virology 50:197-206.
- Katzenelson, E. (1978) Survival of viruses. In Indicators of Viruses in Water and Food, pp. 39-50 (Edited by Berg, G.) Ann Arbor Science, Ann Arbor.
- Katzenelson, E. and Kedmi, S. (1979) Unsuitability of polioviruses as indicators of virological quality of water. Applied and Environmental Microbiology 37(2): 343-344.
- Katzenelson, E., Kletter, B. and Shuval, H.I. (1974) Inactivation on kinetics of viruses and bacteria in water by use of ozone. J. Am. Water Works Assoc. 66:725-729.
- Kedmi, S. and Katzenelson, E. (1978) A rapid quantitative fluorescent antibody assay using tragacanth gum. Archives of Virology 56:337-340.
- Keet, E.E. (1974) Yersinia enterocolitica septicemia. Source of infection and incubation period identified. New York State Journal Med. 74:2226-2229.
- Kenner, B.A. (1978) Fecal streptococcal indicators. In Indicators of Viruses in Water and Food, pp. 147-169 (Edited by Berg, G.), Ann Arbor Science, Ann Arbor.
- Kennet, A.C. (1966) Attack of microorganisms on underground flexible joints. N.Z. Ind. Bull. 22:26-28.
- Kermack, W.O. and McKendrick, A.G. (1927) A contribution to the mathematical theory of epidemics, [Part 1], Proc. Roy. Soc. A 111:700-721.
- Keurings Instituut voor Waterleiding-Artikelen (1961) Testing of Rubber Rings for the Water Industry, KIWA, The Hague, 160 pages.
- Keurings Instituut voor Waterleiding Artikelen (KIWA) (1974) Richtlijnen voor de aanleg van drinkwaterinstallaties in woningen. Rapport uitgebracht door de commissie aanleg binnenleidingen van het KIWA Augustus 1974 Keuringsinstituut voor waterleiding-artikelen N.V. Keurings Instituut voor Waterleiding Artikelen, The Hague

- Keurings Instituut voor Waterleiding-Artikelen (KIWA) (1977) Beveiliging tegen het binnendringen van vreemde stoffen in waterleidingen juli 1977, 4e (herziene) druk. The Hague.
- Khanna, P. (1973) Enumeration and differentiation of water bacteria with phosphorous 32. J. Water Poll. Contr. Fed. 45:262-268.
- Kibbey, H.J., Hagedorn, C. and McCoy, E.L. (1978) Use of fecal streptococci as indicators of pollution in soil. Applied and Environmental Microbiology 35(4):711-717.
- King, E.O. (1962) The laboratory recognition of Vibrio fetus and a closely related Vibrio isolated from cases of human vibriosis. Annual New York Academy of Sciences 98:700.
- Kinman, R.N. (1975) Water and wastewater disinfection with ozone: A critical review. Critic. Rev. Environ. Contr. 5:141-152.
- Kinman, R.N., Black, A.P. and Thomas, W.C. Jr. (1970) Status of water disinfection with iodine, pp. 11-35. In Proc. National Specialty Conference on Disinfection. Amherst, Mass. July, 1970. American Society of Civil Eng., New York.
- Kirchmer, C.J. (1971) 5 -cholestan-3 -ol: An indicator of pollution. University of Florida. Ph.D. Thesis.
- Kittrell, F.W. and Furfari, S.A. (1963) Observations of coliform bacteria in streams. J. Water Pollut. Control Fed. 35:1362-1385.
- Kjellander, J. (1960) Enteric streptococci as indicators of fecal contamination of water. Acta Pathologica et Microbiologica Scandinavica Suppl. 136:1-133.
- Kjellander, J. and Lund, E. (1965) Sensitivity of Escherichia coli and poliovirus to different forms of combined chlorine. J. Am. Wat. Wks. Ass. 57:893-900.
- Klein, P.A. and Wu, S.Y. (1974) Stress: A factor to be considered in heterotrophic microorganisms in enumeration from aquatic environments. Appl. Microbiol. 27:429-431.
- Klock, J.W. (1971) Survival of coliform bacteria in wastewater treatment lagoons. Journal of the Water Pollution Control Fed. 43:2071-2083.

- Klotz, M. (1979) Mikrobiologische Untersuchungen zur Trinkwasseraufbereitung mit Aktivkohle. Quantitative Erfassung und Bewertung. Diplom-Arbeit, Universität des Saarlandes, Saarbrücken, FRG.
- Klotz, M., Werner, P. and Schweisfurth, R. (1975) Untersuchungen zur Biologie in Aktivkohlefiltern. In Heft 9:7. Vortragsreihe mit Erfahrungsaustausch über spezielle Fragen der Wassertechnologie-Adsorption, pp. 270-282, Engler-Bunte Institut der Universität Karlsruhe, Karlsruhe, FRG.
- Klotz, M., Werner, P. and Schweisfurth, R. (1976a) Mikrobiologische Untersuchungen der Aktivkohlefiltration zur Trinkwasseraufbereitung. In Forschung und Entwicklung in der Wasserpraxis (Wissenschaftliche Berichte über Untersuchungen und Planungen der Stadtwerke Wiesbaden AG), Band 3, pp. 73-82, Stadtwerke Wiesbaden AG, Wiesbaden, FRG.
- Klotz, M., Werner, P. and Schweisfurth, R. (1976b) Investigations concerning the microbiology of activated carbon filters. In Translation of Reports on Special Problems of Water Technology. Volume 9. Adsorption. Conference Held in Karlsruhe FRG 1975, pp. 312-330, Municipal Environmental Research Laboratory, Office of Research and Development, US Environmental Protection Agency, Cincinnati, Ohio EPA-600/9-76-030, December 1976.
- Knittel, M.D., Seidler, R.J., Eby, C. and Cabe, L.M. (1977) Colonization of the botanical environment by Klebsiella isolates of pathogenic origin. Appl. Environ. Microbiol. 34:557-563.
- Knox, W.E., Stumpf, P.K., Green, D.E. and Auerbach, V.H. (1948) The inhibition of sulfhydryl enzymes as the basis of the bactericidal action of chlorine. J. Bacteriol. 55:451-458.
- Koff, R.S., Chambers, T.C., Culhane, P.O. and Iber, F.L. (1973) Underreporting of viral hepatitis. Gastroenterology 64:1194-1195.
- Konst, H., McKercher, P.D., Gorham, P.R., Robertson, A. and Howell, J. (1965) Symptoms and pathology produced by Microcystis aeruginosa NCR-1 in laboratory and domestic animals. Canadian Journal of Comparative Medicine and Veterinary Science 29:221-228.



- Kool, H.J. (1976) The use of adenosine triphosphate (ATP) as an indicator of biological activity and biomass in ecological studies. Hydrobiol. Bull. 10:145-154.
- Kool, H.J. (1977) Het gedrag van heterotrofe bacterien in relatie tot het fytoplankton in het spaarbekken De Grote Rug en drie model reservoirs. RID rapport CBH 78/09, pp. 1-16, Natl. Inst. for Water Supply, P.O. Box 150, 2260 AD Leidschendam, the Netherlands.
- Kool, H.J. (1978) Treatment processes in public water supply for the removal of microorganisms. Chapter 17. In Biological Indicators of Water Quality, pp. 17-1-17-31 (Edited by James, A. and Evison, L.E.) John Wiley and Sons Ltd., Chichester, UK.
- Koshi, G. and Lalitha, M.K. (1976) Edwardsiella tarda in a variety of human infections. Indian Journal of Medical Research 64:1753-1759.
- Kott, Y. (1966) Estimation of low numbers of Escherichia coli bacteriophages by use of the most probable number method. Appl. Microbiol. 14:141-144.
- Kott, Y., Ben-Ari, H., and Vinokur, L. (1978a) Coliphages survival as viral indicator in various wastewater quality effluents. Prog. Water Technol. 10(1/2):337-346.
- Kott, Y., Ben-Ari, H., and Betzer, N. (1978b) Lagooned, secondary effluents as water source for extended agricultural purposes. Water Res. 12:1101-1106.
- Kovacs, G. (1977) Human interaction with groundwater. Ambio. 6:22-26.
- Kristensen, K., K. (1974) Vandhygiejne, foreliggende viden og forskningsbehov. Publ. by Water Quality Institute, Agern alle 11, Horsholm, Denmark. 293 pages.
- Kristensen, K.K. (1977) Forekomst og overlevelsessevne af Yersinia enterocolitica og Yersinia pseudotuberculosis i spild vand, slam og overfladevand med tilhørende fauna. Vandkvalitetsinstituttet, ATV, 2970 Hørsholm, Denmark.
- Kristensen, K.K. (1978) Endotoxiner-et omgivelseshygiejnisk problem. Vand. 2:54-56.

- Krogstad, O. (1974) Survival of Yersinia enterocolitica in water. Proc. 12th Nordic Vet. Congress Reykjavic, p. 256. A/S Carl Fr. Mortenson, Copenhagen.
- Kruse, C.W., Hsu, Y.C., Griffiths, A.C. and Stringer, R. (1970) Halogen action on bacteria, viruses, and protozoa. In Proceedings of the National Specialty Conference on Disinfection, pp. 113-136. Amer. Society of Civil Eng., New York.
- Kubota, Y. and Liu, P.V. (1971) An enterotoxin of Pseudomonas aeruginosa. J. Infect. Dis. 123:97-98.
- Kullmann, K.H. and Schweisfurth, R. (1978) Eisenoxydierende, stabchenformige Bakterien. II. Quantitative Untersuchungen zum Stoffwechsel und zur Eisenoxydation mit Eisen (II)-Oxalat. Z. Allg. Mikrobiol. 18:321-327.
- Kullmann, K.H. and Schweisfurth, R. (1978) Eisenoxydierende, stabchenformige Bakterien. III. Quantitative Untersuchungen zum Effekt von Eisen auf das Wachstum. Z. Allg. Mikrobiol. 18:427-435.
- Kuster, E. and Williams, S.T. (1964) Selection of media for isolation of streptomycetes. Nature, Lond. 202:928.
- Kuzminski, L.N., Feng, T.H., and Liu, C.C. (1970) Effect of inorganics on disinfection by halogens. In Proceedings of the National Specialty Conference on Disinfection, pp. 85-111, American Society of Civil Engineers, New York (no editor).
- LaBelle, R.L. and Gerba, C.P. (1979) Influence of pH, salinity, and organic matter on adsorption of enteric viruses to estuarine sediment. Applied and Environmental Microbiol. 38:93-101.
- Labonde, J. and Festy, B. (1979) Bilan d'une recherche systematique de Pseudomonas aeruginosa dans les eaux de consommation. Revue de l'Institut Pasteur de Lyon 12:507-517.
- Laboratory Centre for Disease Control (1978) Campylobacter enteritis -- Ontario. Canada Diseases Weekly Report 4:57-58.
- LaGrange, W.S., Moon, N.J. and Reed, W. (1977) The 3M Automatic colony counter in the bacterial evaluation of manufacturing-grade milk. J. Food Prot. 40:11:744-746.

- Lance, J.C., Gerba, C.P. and Melnick, J.L. (1976) Virus movement in soil columns flooded with secondary sewage effluent. Applied and Environmental Microbiol. 32:520-526.
- Lanyi, B.J., Szita, J., Ringelmann, B. and Kovach, K. (1959) A waterborne outbreak of enteritis associated with Escherichia coli serotype 124:72:32. Acta microbiol. acad. sci. Hung 6:77-84.
- Lassen, J. (1972) Yersinia enterocolitica in drinking water. Scandinavian Journal of Infectious Diseases 4:125-127.
- Leclerc, H. (1967) Mise en évidence de la decarboxylase de l'acide glutamique chez les bactéries à l'aide d'une technique automatique. Ann. Inst. Pasteur 112:713-731.
- Leclerc, H. and Catsaras, M. (1967) Un caractere constant chez l'Escherichia coli: La présence d'une decarboxylase de l'acide glutamique. Bull. Ass. Dipl. Microbiol. Nancy 107:39-49.
- Leclerc, H., Mizon, F., Boniface, B. and Boniface, M. (1977a) Eaux et bactéries résistantes aux antibiotiques: Etude écologique. Ann. Microbiol. (Inst. Pasteur) 128 B:253-265.
- Leclerc, H., Mossel, D.A.A., Trinel, P.A. and Gavini, F. (1977b) Microbiological monitoring -- a new test for fecal contamination. In Bacterial Indicators Health Hazards Associated with Water ASTM STP 635, pp. 21-31 (Edited by Hoadley, A.W. and Dutka, B.J.) American Society for Testing and Materials, Philadelphia.
- Lee, P.K. (1972) Role of crucian carp in transmission of enteric pathogens. J. Cath. Med. Col. (Korea) 23: 379-386.
- Lee, S.H., O'Conner, J.T. and Banerji, S.K. (1977) Biologically mediated deterioration of water quality in distribution systems. Paper 3B-2, Water Works Association, 5th Water Quality Technology Conference, Kansas City, Dec 4-7, 1977. American Water Works Association, Denver, 14 pages.
- Lee, Y., Jablonski, I. and DeLuca, M. (1977) Immobilization of firefly luciferase on glass rods: Properties of the immobilized enzyme. Analytical Biochem. 80:496-501.

- Leefflang, K.W.H. (1963) Microbiologic degradation of rubber. Journal of the American Water Works Association 55:1523-1535.
- Leffler, E. and Kott, Y. (1974) Enteric viruses behaviour in sand dunes. Israel J. of Techn. 12:298-304.
- Leiguarda, R.H., Peso, O.A. and Palazzolo, A.Z. (1949) Bactericidal action of ozone. An. Assoc. Quim. Argent. 37:165-176.
- Lennette, E.H., Spaulding, E.H. and Truant, J.P. (1974) Manual of Clinical Microbiology, 2nd edition, American Society for Microbiology, Washington, D.C., 970 pages.
- Levin, G.V. (1963) Rapid microbiological determinations with radioisotopes. Advances in Applied Microbiology (Edited by Umbreit, W.W.) 5:95-133, Academic Press, New York, USA.
- Levin, G.V. (1968) Experiments and instrumentation for extraterrestrial life detection. Advances in Applied Microbiology (Edited by Umbreit, W.W. and Perlman, D.) Academic Press, New York, USA, 10:55-71.
- Levin, G.V., Harrison, V.R., Hess, W.C. and Gurney, H.C. (1956) A radioisotope technique for the rapid detection of coliform organisms. Am. J. Public Health 46:1405-1414.
- Levin, J. and Bang, F.B. (1964) A description of cellular coagulation. In Limulus Bull., Johns Hopkins Hosp. 115:337.
- Levin, M.A. (1977) Bifidobacterium as water quality indicators. In Bacterial Indicators/Health Hazards Associated with Water ASTM STP 635 (Edited by Hoadley, A.W. and Dutka, B.J.) pp. 131-138.
- Levin, M.A., and Cabelli, V.J. (1972) Membrane filter technique for enumeration of Pseudomonas aeruginosa. Appl. Microbiol. 24:864-870.
- Levin, M.A., Fischer, J.R. and Cabelli, V.J. (1974) Quantitative large-volume sampling technique. Appl. Microbiol. 28:515-517.

- Levine, M.H., Dupont, H.L. and Formal, S.B. (1973) Pathogenesis of Shigella dysenteriae (Shiga) dysentery. J. Infect. Dis. 127:261-270.
- Levy, B.S., Mature, J. and Washburn, J.W. (1977) Intensive hepatitis surveillance in Minnesota: Methods and results. Am. J. Epidemiol. 105:127-134.
- Liao, S.J., Berg, F.P. and Bonchard, R.J. (1954) Epidemiology of infectious hepatitis in an urban population group. Yale J. Biol. Med. 26:512-526.
- Lin, S. (1977) Evaluation of methods for detecting coliforms and fecal streptococci in chlorinated secondary sewage effluents. In Symposium on the Recovery of Indicator Organisms Employing Membrane Filters. (Edited by Bordner, R.H., Frith, C.H., and Winter, J.A.) U.S. E.P.A., Cincinnati, Ohio, U.S.A., pp. 113-132.
- Liu, O.C. (1973) Effect of chlorination on human enteric viruses in partially treated water from the Potomac River estuary. Study report, U.S. Army Engineer Division, North Atlantic Philadelphia, 118 pages.
- Lloyd, B.C. (1973) The construction of a sand profile sampler, its use in the study of the Vorticella populations and the general interstitial microfauna of slow sandfilters. Water Res. 7:963-973.
- Lothrop, T.L. and Sproul, O.J. (1969) High-level inactivation of viruses in wastewater by chlorination. J. Wat. Poll. Control Fed. 41:567-575.
- Lovelock, D.W. and Gilberg, R.J. (Editors) (1975) Microbial Aspects of the Deterioration of Materials. Society for Applied Bacteriology, Technical Series 9, Academic Press, London.
- Lovtsevich, E.L. (1973) Certain aspects of the processes of enterovirus inactivation with chlorine (in Russian). Gig. Sanit. 10:11-15.
- Lowbury, E.J.L., Thom, B.T., Lilly, H.A., Rabb, J.R., and Whittall, K. (1970) Sources of infection with Pseudomonas aeruginosa in patients with tracheotomy. Journal of Medical Microbiology 3:39.

- Lund, E. (1963) Effect of pH on the oxidative inactivation of poliovirus. Arch. Ges. Virusforsch. 12:632-647.
- Lund, E. (1978) Human pathogens as potential health hazards in the reuse of water. Ambio. 7:56-61.
- Luttmann, U. (1967) Investigation into the biology of free-growing Salmonellas in the Weser-Leine region during 1964-7. Gesundheitswes. Desinfekt. 59:139, 159 and 180.
- Lycke, E., Blomberg, J., Berg, G., Eriksson, A. and Madsen, L. (1978) Epidemic acute diarrhea in adults associated with infantile gastroenteritis virus. Lancet 1056-1057.
- Mack, W.N. (1977) Total coliform bacteria. In Bacterial Indicators/Health Hazards Associated with Water ASTM STP 635, pp. 59-64 (Edited by Hoadley, A.W. and Dutka, B.J.) American Society for Testing and Materials, Philadelphia.
- Mackenthun, K.M. and Ingram, W.M. (1967) Biological Associated Problems in Freshwater Environments. US Dept. of the Interior, FWPCA, Washington, D.C., 287 pages.
- MacKenzie, E.F.W., Taylor, E.W. and Gilbert, W.E. (1948) Recent experiences in the rapid identification of Bacterium coli Type 1. Journal of General Microbiology 2(2):197-204.
- Madeley, C.R. (1979) Viruses in the stools. J. Clin. Path. 32:1-10.
- Mahnel, H. (1977) Untersuchungen zur Virusinaktivierung in Trink und Oberflächenwasser. Ein Beitrag zur Dekontamination von trinkbaren Wassern mit Feldangleichen Methoden. Zbl. Bakt. Hyg. 1, Abt. Orig. B 165:527-538.
- Mair, I.W.S., Natvig, K. and Johannessen, T.A. (Sept., 1973) Otolaryngological manifestations of tularemia. Arch. Otolaryngol. 98:156-158.
- Majumdar, S.B., Ceckler, W.H. and Sproul, O.J. (1974) Inactivation of poliovirus in water by ozonation. J. Water Poll. Control Fed. 8:2048-2053.
- Marier, R. (1977) The reporting of communicable diseases. Am. J. Epidemiol. 105:587-590.

- McCabe, L.J. (1977) Epidemiological consideration in the application of indicator bacteria in North America. In Bacterial Indicators/Health Hazards Associated with Water, pp. 15-22, ASTM STP 635 (Edited by Hoadley, A.W. and Dutka, B.J.) American Society for Testing and Materials, Philadelphia.
- McCoy, J.H. (1962) The isolation of salmonellae. J. Appl. Bacteriol. 25:213-224.
- McFeters, G.A. and Stuart, D.G. (1972) Survival of coliform bacteria in natural waters: Field and laboratory studies with membrane-filter chambers. Appl. Microbiol. 24:805-811.
- McFeters, G.A., Bissonnette, G.K., Jezeski, J.J., Thomson, C.A. and Stuart, D.G. (1974) Comparative survival of indicator bacteria and enteric pathogens in well water. Appl. Microbiol. 27:823-829.
- McCarthy, J.A. (1944) Bromine and chlorine dioxide as water disinfectants. J. New Eng. Water Works Assoc. 58:55-68.
- McCarthy, J.A. (1945) Chlorine dioxide for the treatment of water supplies. J. New Eng. Water Works Assoc. 59:252-261.
- Melnick, J.L. and Ledinko, N. (1951) Social serology: Antibody levels in a normal young population during an epidemic of poliomyelitis. Amer. Journal of Hygiene 54:354-382.
- Melnick, J.L., Gerba, C.P. and Wallis, C. (1978) Viruses in water. Bulletin of the World Health Organization 56(4):499-508.
- Mendis, N.M., De La Motte, P.U., and Gunatillaka, P.D. (1976) Protected infection with Salmonella bareilly in a maternity hospital. J. Tropical Med. Hyg. 79:142-150.
- Mercado-Burgos, N., Hoehn, R.C., and Holliman, R.B. (1975) Effect of halogens and ozone on Schistosoma ova. J. Water Poll. Control Fed. 47:2411-2419.
- Metcalf, T.G. (1961) Use of membrane filters to facilitate the recovery of virus from aqueous suspensions. Applied Microbiol. 9:376-381.

Metropolitan Water Board Report (1966) Pollution by gulls. Report on the results of the bacteriological, chemical and biological examination of the London Waters 42:20-21.

Metropolitan Water Board (1967-1968) Thirty-third report on the results of the bacteriological, chemical and biological examination of the London waters. Ecological studies of slow sand filter algae 43:61-65.

Metropolitan Water Board (1969-1970a) Thirty-fourth report: Aerobic sporing bacilli, fungi and actinomyces in slow sand filters. Escherichia coli in "blanket weed" 44:16-23.

Metropolitan Water Board (1969-1970b) Experimental studies of slow sand filtration 44:83-86.

Metropolitan Water Board Report (1970a) Gulls on filter beds. Report on the results of the bacteriological, chemical and biological examination of the London waters 44:24-25.

Metropolitan Water Board Report (1970b) Silt deposits in service reservoirs. Report on the results of the bacteriological, chemical and biological examination of the London waters 44:39-42.

Metropolitan Water Board Report (1970c) Biodegradation of jointing compounds. Report on the results of the bacteriological, chemical and biological examination of the London waters 44:42-47.

Metropolitan Water Board (1971-1973a) Thirty-fifth report: Slow sand filtration 45:27-53.

Metropolitan Water Board (1971-1973b) Reports on Research Work -- Bacteriological, chemical, and biological examination of London water. Metropolitan Water Board 45:147.

Metropolitan Water Board Report (1973a) Silt deposits in service reservoirs. Ibid. 45:26.

Metropolitan Water Board Report (1973b) Prefiltration ozonation. Report on the results of the bacteriological, chemical and biological examination of the London waters 45:49-53.



- Mikkelsen, T. (1977) Palaeozoiske principper i moderne medicin. Dansk Kemi 60:76-82.
- Miller, G.W., Rice, R.G., Robson, C.M., Scullin, R.L., Kuhn, W., and Wolf, H. (1978) An assessment of ozone and chlorine dioxide technologies for treatment of municipal water supplies. U.S. Environmental Protection Agency Final Report EPA-600/2-78-147.
- Miller, J.D.A. (Editor) (1971) Microbial Aspects of Metallurgy. Medical and Technical Publishing Co., Chiltern House, Aylesbury, UK.
- Miller, L., Snyder, P., Trout, J.R., and Sousner, M. (1975) Improvement in accuracy of automatic colony counter through use of calibration factors. Paper Q27. Abstracts of the Annual Meeting, American Society for Microbiology, p. 209. Presented at 16th meeting of ASM, N.Y.
- Mitchell, D.O. and Starzyk, M.J. (1975) Survival of Salmonella and other indicator microorganisms. Can. J. Microbiol. 21:1420-1421.
- Mitchell, R.I. (1972) Ecological control of microbial imbalances. In Water Pollution Microbiology, pp. 273-288 (Edited by Mitchell, R.) Wiley Interscience, New York.
- Moffa, P.E., Tifft, E.C., Richardson, S.L. and Smith, J.E. (1975) Benchscale high rate disinfection of combined sewer overflows with chlorine and chlorine dioxide. U.S. Environmental Protection Agency Final Report EPA-670/2-75-021.
- Moore, B.E., Sagik, B.P. and Sorber, C.A. (1977) An assessment of potential health risks associated with land disposal of residual sludges. Presented at the Third National Conference on Sludge Management Disposal and Utilization, December 14-16, 1976 (Miami, Florida) 108 Information Transfer, Inc., Rockville, Maryland.
- Mohadjer, S. and Mehrabian, S. (1975) Studies on the survival of Shigella flexneri in river and tap water. Arch. Roum. Exp. Microbiol. 34:307-312.

- Mohrmann, R. (1927) Die Hannoversche Typhusepidemie Im Jahre 1926. Veroffentl. a. d. Geb. d. Med.-Verwalt 24:393-444.
- Mollaret, H.H. (1976) Contribution a l'étude épidémiologique des infections a Yersinia enterocolitica. III. Bilan provisoire des connaissances. Med. Mal. Infect. 6:442-448.
- Monnet, P., Buttiaux, R., Papavassiliou, J., Nicolle, P., and Le Minor, S. (1954) Escherichia coli des types O111 et O55 dans des eaux d'alimentation. Ann. Inst. Pasteur. 87:347-349.
- Moore, G.T., McGuire, C.M., Mollohan, C.S., Gleason, N.N., Healy, G.R. and Newton, L.H. (1969) Epidemic giardiasis at a ski resort. New England Journal of Med. 281:402-404.
- Morello, J.A. (1975) Automated radiometric detection of bacteria. Automation in Microbiology and Immunology (Edited by Heden, C.G. and Illeni, T.) pp. 35-46, John Wiley & Sons, New York, USA.
- Morris, G.K. and Feeley, J.C. (1976) Yersinia enterocolitica: A review of its role in food hygiene. Bull. World Health Organization 54:79-85.
- Morris, J.C. (1967) The future of chlorination. J. Am. Wat. Wks. Ass. 58:1475-1482.
- Morris, J.C. (1970) Disinfectant chemistry and biocidal activities. In Proceedings of the National Specialty Conference on Disinfection, Massachusetts, pp. 609-633, American Society of Civil Engineers, New York.
- Morris, J.C. (1975) Aspects of the quantitative assessment of germicidal efficiency, pp. 1-10 in Disinfection: Water and Wastewater. (Edited by Johnson, J.D.) Ann Arbor Science Publishers, Inc., Ann Arbor, Mich.
- Morris, J.C., Chang, S.L., Fair, G.M. and Conant, G.H., Jr. (1953) Disinfection of drinking water under field conditions. Ind. and Eng. Chem. 45:1013-1015.
- Mosley, J.W. (1967) Transmission of viral diseases by drinking water. In Transmission of Viruses by the Water Route, pp. 5-23 (Edited by Berg, G.), Interscience Publishers, New York.

- Mosley, W.H. (1970) Principles and practice of cholera control. Public Health Papers, World Health Organization 40:23-27.
- Mudd, J.B. and Freeman, B.A. (1977) Reaction of ozone with biological membrane. In Biochemical Effects Environmental Pollutants, pp. 97-133 (Edited by Duk, S.L.) Ann Arbor Sci. Publishers, Ann Arbor, Michigan.
- Müller, G. (1961) Probleme einer bakteriologisch einwandfreien Trinkwasserversorgung auf kleineren Schiffen. Stadtehygiene 12:113-114.
- Müller, G. (1964) Welche Konsequenzen ergeben sich aus den Erfahrungen der Hamburger Flutkatastrophe für die hygienische Trinkwasseruntersuchung? Arch. Hyg. 148:321-327.
- Müller, G. (1965) Salmonella in bird faeces. Nature, pp. 5003:1315.
- Müller, G. (1967) Das Vorkommen von agglutinierenden E. coli -- Typen in Trink- # und Oberflächenwassern. Z. Bakt. Parasitenkunde, Infektionskrankheiten und Hygiene I Orig. 203:464-468.
- Müller, G. (1969a) Die gesundheitliche Bedeutung der Ratten. Schriftenreihe Wa-BO-Lu 32:9-18.
- Müller, G. (1969b) Wasserversorgung. In Das Öffentliche Gesundheitswesen, Vol. 3, pp. 353-390 (Edited by Trub, C.L.P., Daniels, F. and Posch, F.) Georg Thieme Verlag, Stuttgart.
- Müller, G. (1974) Vorkommen und Bedeutung technisch unerwünschter Bakterien in der Trinkwasserversorgung. Zbl. Bakt. Hyg. I. Abt. Orig. A 227:50-55.
- Müller, G. (1976) Die Überwachung der Wasserversorgung von Schiffen nach der Trinkwasser-Verordnung. In Die Trinkwasser-Verordnung, Einführung und Erläuterungen für Wasserversorgungsunternehmen und Überwachungsbehörden, pp. 57-64 (Edited by Aurand, K., Hasselbarth, U., Müller, G., Schumacher, W., Steuer, W. and Schmidt, E.) Verlag Berlin.
- Müller, G. (1977a) Non agglutinable cholera vibrios (NAG) in sewage, river water and seawater. Zbl. Bakt. Hyg., I. Abt. Orig. B 165:487-497.

- Müller, G. (1977b) Bacterial indicators and standards for water quality in the Federal Republic of Germany. In Bacterial Indicators/Health Hazards Associated with Water. ASTM STP 635, pp. 159-167 (Edited by Hoadley, A.W., Dutka, B.K.) American Society for Testing and Materials, Philadelphia.
- Müller, G. und Herzel, F. (1973) Chemische, mikroskopische und bakteriologische Untersuchungen an Ionenaustauscherharzen. Z. Bakt. Hyg. Abt. I. Orig. B 156:S. 524.
- Müller, G., Goethe, H. and Herrmann, R. (1968) Bakteriologische Untersuchungen an Verdampferanlagen zur Trinkwasserversorgung auf Seeschiffen. Zbl. Bakt. I. Abt. Orig. 207:409-418.
- Müller, G., Goethe, H. and Herrmann, R. (1972) Bakteriologische Untersuchungen zur Trinkwasserdesinfektion durch UV-Bestrahlung an Bord von Seeschiffen. Mittlg. Zbl. Bakt. Hyg. I. Abt. Orig B 156:361-372.
- Müller, G., Kempf, Th., Goethe, H. and Herrmann, R. (1977) Trinkwasserkonserven für Rettungsboote. Forum Umwelthygiene 28:33-34.
- Müller, Gertrud, Althaus, H., Hamburger, B., Schubert, R.W. and Selenka, F. (1979) Mitteilung über eine Methode zur Prüfung von Kunststoffen im Trinkwasserbereich mit Hilfe von Bakterien. (Bundesgesundheitsblatt, in press).
- Mundt, J.O. and Graham, W.F. (1968) Streptococcus faecium variety casseliflavus, nov.var. Journal of Bacteriology. 95(6):2005-2009.
- Munger, S.F., Heyward, A.A and Swartz, R.G. (1977) Inactivation of virus by chlorination or ozonation in four wastewater treatment system effluents. Paper Q47. Abstracts of the Annual Meeting, Am. Soc. Microbiol., New Orleans, p. 269. Washington, D.C.
- Munoz, E.F. and Silverman, M.P. (1979) Rapid, single-step most probable number method for enumerating fecal coliforms in effluents from sewage treatment plants. Appl. Environ. Microbiol. 37(3):527-530.

- Murray, C.R. and Reeves, E.B. (1977) Estimated Use of Water in the United States in 1975, Geological Survey Circular 765. US Geological Survey, Department of the Interior, Arlington, Virginia.
- Murray, R.G.E. (1965) Location of mucapeptide of selections of the cell wall of *E. coli* and other gram-negative bacteria. Can. J. Microbiol. 11:547-560.
- Murtaugh, J.J. and Bunch, R.L. (1967) Sterols as a measure of fecal pollution. J. Water Pollut. Contr. Fed. 39:404-409.
- Naemura, L.G. and Seidler, R.J. (1978) Significance of low-temperature growth associated with the fecal coliform response, indole production and pectin liquifaction in *Klebsiella*. Appl. Environ. Microbiol. 35:392-396.
- Nagington, J., Watson, P.G., Playfair, T.J., McGill, J., Jones, B.R., and Steele, A.D.M. (1974) Amebic infection of the eye. Lancet, December 28, pp. 1537-1540.
- Nath, S. (1974) Histopathological and radiological appearance of duodenum in giardiasis. Indian Journal of Medical Research 62:719.
- Neefe, J.R. and Stokes, J. (1945) An epidemic of infectious hepatitis apparently due to a waterborne agent. Journal of the American Medical Assoc. 128:1063-1075.
- Nemedi, L. and Lany, B. (1971) Incidence and hygienic importance of *Pseudomonas aeruginosa* in water. Acta Microbiol. Acad. Sci. Hung. 18:319-326.
- Nestor, I., and Costin, L. (1971) The removal of Coxsackie virus from water by sand obtained from the rapid sand filters of water plants. J. Hyg. Epidem. Microbiol. Immun. 15:129-136.
- Newson, S.W.B. (1968) Hospital infection from contaminated ice. Lancet II:620.
- Newton, W.L. and Jones, M.F. (1949) Effect of ozone in water on cysts of *Entamoeba histolytica*. Amer. Journal of Tropical Med. 29:669-681.
- New Zealand Department of Scientific and Industrial Research (1969) Degradation of Rubber Ring Pipe Joints. NZ DSIR Ann Rept., 1969, pp. 19-20.

- Nilehn, B. (1973) The relationship of incubation temperature to serum bactericidal effect, pathogenicity and in vivo survival of *Yersinia enterocolitica*. In Contributions to Microbiology and Immunology, Vol. 2, pp. 85-92 (Edited by Winblad, S.) Karger, Basel.
- Norwegian Institute of Water Research (1980) Bacteriological relations in Norwegian and foreign raw water sources, Report number 0-78029. Norwegian Institute of Water Research, Box 333, Blindern, Oslo 3, 74 pages.
- Nusbaum, I. (1952) Sewage chlorination mechanism. A survey of fundamental factors. Water Sewage Works 99:295-297.
- O'Connor, J.T., Hash, L. and Edwards, A.B. (1975) Deterioration of water quality in distribution systems. Journal of the American Water Works Assn. 67:113-116.
- Offut, A.C., Poole, B.A. and Fassnacht, G.G. (1955) A waterborne outbreak of amebiasis. Amer. Journal of Public Health 45:486-491.
- Oger, C., Catteau, M. and Leclerc, H. (1976) Etude, en laboratoire, de la survie des Salmonella dans une eau polluée. Microbia. 2:3-9.
- Olivieri, V.P. (1968) Chlorine dioxide and protein synthesis. Master's Thesis. West Virginia Univ., Morgantown, West Virginia.
- Olivieri, V.P., Krusé, C.W., Hsu, Y.C., Griffiths, A.C. and Kawata, R. (1975) The comparative mode of action of chlorine, bromine and iodine in f. bacterial virus, 145-162 in Disinfection: Water and Wastewater (Edited by Johnson, J.D.) Ann Arbor Science Publishers, Inc., Ann Arbor, Mich.
- Ontario Ministry of the Environment (1976) The presence-absence procedure. Handbook of Analytical Methods for Environmental Samples. Laboratory Services Branch, Ministry of the Environment, P.O. Box 213, Rexdale, Ontario, Canada.
- Opara, A.A. (1978) The role of anaerobic faecal bacteria as indicators of water pollution in hot climates. Ph.D. Thesis, University of Dundee.

- Orchard, V.A. and Goodfellow, M. (1974) The selective isolation of Nocardia from soil using antibiotics. J. Gen. Microbiol. 85:160-162.
- Oremland, R.S. and Silverman, M.P. (1979) Microbial sulfate reduction measured by an automated electrical impedance technique. Geomicrobiol. J. (in press).
- Ørskov, I. (1974) Klebsiella. In Bergey's Manual of Determinative Bacteriology 8th ed., pp. 321-324 (Edited by Buchanan, R.E. and Gibbons, N.E.) Williams and Wilkins, Baltimore, Maryland.
- Padchenko, I.K. and Stolyarchuk, N.G. (1969) On the possible circulation of G. lamblia in nature. Prog. Protozool. 3:311-312.
- Pai, C.H., Sorger, R.T., Lackman, L., Sinai, R.E. and Marks, M.I. (1979) Campylobacter gastroenteritis in children. Journal of Pediatrics 94:589-591.
- Palfi, A.B. (1971) Virus content of sewage in different seasons in Hungary. Acta Microbiologica Academiae Scientiarum Hungaricae 18:231-237.
- Palmer, C.M. (1962) Taste and odor algae. In Algae in Water Supplies, Chapter IV, pp. 18-21, US Dept. of Health, Education and Welfare, Public Health Service, 88 pages.
- Panigrahy, B., Grimes, J.E., Rideout, J.E., Simpson, R.B., and Grumbles, L.C. (1979) Apparent increased occurrence of chlamydiosis (psittacosis), salmonellosis, and giardiasis. Journal of the Amer. Veterinary Med. Assoc. 175:359-361.
- Parmentier, G.G. and Eyssen, H.J. (1974) Mechanism of biohydrogenation of cholesterol to coprostanol by Eubacterium ATCC 21408. Biochim. Biophys. Acta 348: 279-284.
- Pavoni, J.L., Tittlebaum, M.E., Spencer, H.T., Fleischman, M., Nebel, C., and Gottschling, R. (1972) Virus removal from wastewater using ozone. Water Sew. Works 119:59-67.
- Perrich, J.R. (1976) Inactivation of Escherichia coli by ozonation in an aqueous reactor system. Thesis for the degree of Doctor of Philosophy, Univ. of Louisville, Kentucky.

- Pfeiffer, K.R. (1973) The homestead typhoid outbreak. J. Amer. Water Works Assoc. 65:803-805.
- Philips, B.P., Wolfe, P.A., Rees, C.W., Gordon, H.A., Wright, W.H. and Reyniers, J.A. (1955) Studies on the amoeba bacteria relationship in amoebiasis. Comparative results of the intracecal inoculation of germ-free non-contaminated and conventional guinea pigs with Entamoeba histolytica. American Journal of Tropical Med. Hyg. 4:675-692.
- Picciolo, G.L., Thomas, R.R., Deming, J.W., Chappelle, E.W. (1977a) Environmental applications of the firefly luciferase ATP assay flow techniques for monitoring the wastewater effluent and of drinking water supplies. In Proceedings of the Second Bi-Annual ATP Methodology Symposium, pp. 547-564, SAI Technology, 4060 Sorrento Valley Blvd., San Diego, California.
- Picciolo, G.L., Chappelle, E.W., Thomas, R.R. and McGarry, M.A. (1977b) Performance characteristics of a new photometer with a moving filter-tape for luminescence assay. Appl. Environ. Microbiol. 34:720-724.
- Picciolo, G.L., Chappelle, E.W., Deming, J.W., Thomas, R.R., Nibley, A. and Okrend, H. (1981) Firefly luciferase ATP assay development for monitoring bacterial concentrations in water supplies. Environmental Protection Agency (EPA-600/32-81-04) Cincinnati, Ohio.
- Pijck, J. and Defalque, A. (1963) Le. depistage precoce de microorganismes coliformes par voie radiometrique. J. Pharm. Belg. 18:180-190.
- Pipes, W.O. (Editor) (1978) Water Quality and Health Significance of Bacterial Indicators of Pollution, Workshop Proceedings, National Science Foundation and Drexel University, Philadelphia.
- Pollitzer, R. (1967) History and Incidence of Tularemia in the Soviet Union; A Review. The Institute of Contemporary Russian Studies, Fordham Univ., Bronx, New York, 366 pages.
- Popp, L. (1974) Salmonella and natural purification of polluted waters. Zentralbl. Bakteriol. Hyg. Abt. orig. B 158:432-445.



- Portnoy, B.L., Mackowiak, P.A., Caraway, C.T., Walker, J.A., McKinley, T.W. and Klein, C.A. (1975) Oyster-associated hepatitis. Journal of the American Medical Association 233(10):1065-1068.
- Postgate, J.R. (1976) Death in macrobes and microbes. In Twenty-sixth Symposium of the Society for General Microbiology. The Survival of Vegetative Microbes, pp. 1-18 (Edited by Gray, T.R.G. and Postgate, J.R.) Cambridge Univ. Press, Massachusetts.
- Poynter, S.F.B. and Mead, G.C. (1964) Volatile organic liquids and slime production. Journal of Applied Bacteriology 27:182-195.
- Poynter, S.F.B. and Slade, J.S. (1977) The removal of viruses by slow sand filtration. Prog. Water Tech. 9:75-88.
- Poynter, S.F.B. and Stevens, J.K. (1975) The effects of storage on the bacteria of hygienic significance. Proceedings of a Symposium, The Effects of Storage on Water Quality, Water Research Centre, Medmenham Laboratory, Henley Road, Medmenham, Marlow, Bucks, Henry Ling Ltd., Dorchester, 90 pages.
- Poynter, S.F.B., Slade, J.S. and Jones, H.H. (1973) The disinfection of water with special reference to viruses. Water Treatment Examination 22:194-208.
- Prat, R., Nofre, C. and Cier, A. (1968) Effets de l'hypochlorite de sodium, de l'ozone et des radiations ionisantes sur les constituants pyrimidiques de Escherichia coli. Ann. Inst. Pasteur 114:595-607.
- Price, A.T. and Valadon, L.R.G. (1970) A bacteriological study of a new Thames Valley Reservoir. Microbios. 2:269-271.
- Ptak, D.J., Ginsburg, W. and Willey, B.F. (1973) Identification and incidence of Klebsiella in chlorinated water supplies. J. American Water Works Assoc. 65:604-607.
- Raj, H. (1966) Enrichment medium for selection of Salmonella from fish homogenate. Appl. Microbiol. 14:12-20.
- Reasoner, D.J. (1977) Microbiology: Detection of bacterial pathogens and their occurrence. Literature Review. Journal of the Water Pollution Control Fed. 49:1279-1290.

- Reasoner, D.J. (1978) Microbiology: Detection of bacterial pathogens and their occurrence. Literature Review. Journal of the Water Pollution Control Fed. 50:1382-1395.
- Reasoner, D.J. and Geldreich, E.E. (1978) Rapid detection of waterborne fecal coliforms by  $^{14}\text{CO}_2$  release. Mechanizing Microbiology (Edited by Sharpe, A.N. and Clarke, D.S.) pp. 120-139, C.A. Thoman, Springfield, Illinois, U.S.A.
- Reasoner, D.J., Blannon, J.C. and Geldreich, E.E. (1976) The seven hour fecal coliform test. In Proc. Am. Water Works Assoc. Water Quality Technol. Confr. Paper No. 3B-5 (held in San Diego, Calif.) Am. Water Works Assoc., Denver, Colorado.
- Reijnen, G.K. (1973) De werking van een langzame zandfilter met betrekking tot de reductie van het kiemgetal en de afname van de hoeveelheid organische stof. Keurings-instituut voor Waterleidingartikelen (KIWA) city rapport nr. SW-156. Rijswijk, The Netherlands, 24 pages.
- Rennie, R.P. and Duncan, I.B.R. (1974) Combined biochemical and serological typing of clinical isolates of Klebsiella. Appl. Microbiol. 28:534-539.
- Resnick, G. and Levin, M.A. (1977) Enumeration of bifidobacterium in aquatic and fecal samples. Paper Q9 p. 263. Abs. Ann. Meeting (1977) Am. Soc. Microbiol.
- Rexing, D.J. (1977) ATP analysis of a potable water supply. In Proceedings of the Second Bi-Annual ATP Methodology Symposium, pp. 391-395, SAI Technology, 4060 Sorrento Valley Blvd., San Diego, California.
- Ridenour, G.M. and Armbruster, E.M. (1949) Bactericidal effects of chlorine dioxide. J. Am. Water Works Assoc. 41:537-550.
- Ridenour, G.M. and Ingols, R.S. (1946) Inactivation of poliomyelitis virus by free chlorine. Am. J. Pub. Hlth. 36:639-644.
- Ridenour, G.M. and Ingols, R.S. (1947) Bactericidal properties of chlorine dioxide. J. Am. Water Works Assoc. 39:561-567.

- Ridenour, G.M., Ingols, R.S. and Armbruster, E.H. (1949) Sporocidal properties of chlorine dioxide. Water and Sewage Works 96:279-283.
- Ridgway, J., Ainsworth, R.G. and Gwilliam, R.D. (1978) Water quality changes -- chemical and microbiological studies. Proc. Conf. Water Distribution Systems, 1978. Paper 4, Session 1. Publ. Water Research Centre, Medmenham.
- Ritchie, L.S. and Davis, C. (1948) Parasitological findings and epidemiological aspects of epidemic amebiasis occurring in occupants of the Mantetsu Apartment Building, Tokyo, Japan. Amer. Journal of Trop. Med. 28:803-816.
- Rittenberg, S.C. (1972) The obligate autotroph -- the demise of a concept. Antonie van Leeuwenhoek. 38:437-458.
- Rivas, M.G. (1967) Influence of water and sewage treatment processes on Schistosomes. Med. Bull. Standard Oil Co. 27:280-293.
- Robeck, G.G., Clarke, N.A., Dostal, K.A. (1962) Effectiveness of water treatment processes in virus removal. J. Am. Wat. Wks. Assoc. 54:1275-1292.
- Rodger, S.M., Schnagl, R.D. and Holmes, I.H. (1975) Biochemical and biophysical characteristics of diarrhea viruses of human and calf origin. Journal of Virol. 16:1229-1235.
- Rook, J.J. (1955) Microbiologic degradation of vulcanized rubber. Appl. Microbiol. 3:302-309.
- Rosen, H.M., Lowthier, F.E. and Clark, R.G. (1974) Get ready for ozone. Water and Wastes Engineering 7:25-31.
- Rosenberg, M.L., Koplan, J.P., Wachsmuth, I.K., Wells, J.G., Gangarosa, E.J., Guerrant, R.L. and Sack, D.A. (1977) Epidemic diarrhea at Crater Lake from enterotoxigenic Escherichia coli. A large waterborne outbreak. Ann. Intern. Med. 86:714-718.

- Rosenblatt, D.H. (1975) Chlorine and oxychlorine species reactivity with organic substances. In Disinfection Water and Wastewater, pp. 249-276 (Edited by Johnson, J.D.) Ann Arbor Sci., Ann Arbor, Mich.
- Rosenkranz, H.S. (1973) Sodium hypochlorite and sodium perborate: Preferential inhibitors of DNA polymerase-deficient bacteria. Mutat. Res. 21:171-174.
- Rudolphs, W., Falk, L.L. and Ragotzkie, R.A. (1950a) Literature review on the occurrence and survival of enteric, pathogenic and relative organisms in soil, water, sewage and sludges, and on vegetation. I. Bacterial and viral diseases. Sewage Ind. Wastes 22:1261-1281.
- Rudolphs, W., Falk, L.L. and Ragotzkie, R.A. (1950b) Literature review on the occurrence and survival of enteric, pathogenic and relative organisms in soil, water, sewage and sludges, and on vegetation. II. Animal parasites. Sewage Ind. Wastes 22: 1417-1427.
- Ruys, A.C. (1940) On the behavior of E. typhi in surface water. Antonie van Leeuwenhoek J. Microbiol. Serol. 7:93-103.
- Sadzikowski, M.R., Sperry, J.G. and Wilkins, T.D. (1977) Cholesterol-reducing bacterium from human feces. Appl. and Environ. Microbiol. 34:355-362.
- Safe Drinking Water Committee (1977) Drinking Water and Health. National Academy of Sciences, Washington, D.C., 939 pages.
- Sarrette, B.A., Donglot, C.D. and Vilagenes, R. (1977) A new and simple method for recuperation of enteroviruses from water. Water Research 11:355-358.
- Scarpino, P.V., Berg, G., Chang, S.L., Dahling, D., and Lucas, M. (1972) A comparative study of the inactivation of viruses in water by chlorine. Water Res. 6:959-965.
- Scarpino, P.V., Lucas, M., Dahling, D.R., Berg, G. and Chang, S.L. (1974) Effectiveness of hypochlorous acid and hypochlorite ion in destruction of viruses and bacteria, pp. 359-368. In Chemistry of Water Supply, Treatment and Distribution (Edited by Rubin, A.J.), Ann Arbor Science Publishers, Ann Arbor, Michigan.

- Schantz, E.J., Ghazarossian, V.E., Schnoes, H.K., Strong, F.M., Springer, J.P., Pezzanite, J.O. and Clardy, J. (1975) The structure of saxitoxin. Journal of the American Chemical Society 97:1238-1239.
- Schothorst, M. van (1976) Resuscitation of injured bacteria in foods. In Inhibition and Inactivation of Vegetative Microbes, Soc. Appl. Bacteriol. Symp. Ser. 5, pp. 317-328 (Edited by Skimmer, F.A. and Hugo, W.B.) Academic Press, London.
- Schubert, R.H.W. (1967a) Die Pathogenität der Aeromonaden für Mensch und Tier. Arch. Hyg. 150:709-716.
- Schubert, R.H.W. (1967b) Das Vorkommen der Aeromonaden in oberirdischen Gewässern. Arch. Hyg. 150:668-708.
- Schubert, R.H.W. (1967c) Das Schicksal der Aeromonaden in Kläranlagen, Faulturmen und in der Erde. Arch. Hyg. 151:243-258.
- Schubert, R.H.W. (1975a) Der Nachweis von Sporen der Bacillus species im Rahmen der hygienischen Wasserbeurteilung. Zbl. Bakt. Hyg. I Abt. Original B 160:155-162.
- Schubert, R.H.W. (1975b) Die Relation von aerogenen zu anaerogenen Aeromonaden der "Hydrophila-Punctata-Gruppe" in Fließgewässern in Abhängigkeit von der Abfallstoffbelastung. Zbl. Bakt. Hyg., I. Abt. orig. B 610:237-247.
- Schubert, R.H.W. (1976) Der Nachweis von Aeromonaden der "Hydrophila-Punctata-Gruppe." In Rahmen der Hygienischen Trinkwasserbeurteilung. Zbl. Bakt. Hyg., I Abt. Orig. B 161:482-497.
- Schubert, R.H.W. and Blum, U. (1974a) Zur Frage der Erweiterung der hygienischen Wasserkontrolle auf den Nachweis von Pseudomonas aeruginosa. Unpublished Manuscript.
- Schubert, R.H.W. and Blum, U. (1974b) Zur Frage der Eignung der Malachitgrün - Bouillon nach Habs und Kirchner als Anreicherungsmedium für Pseudomonas aeruginosa aus dem Wasser. Zbl. Bakt. Hyg., I. Abt. Orig. B 158:583-587.
- Schubert, R.H.W. and Schäfer, E. (1971) Vergleichende Untersuchungen über die Eliminierung von Viren, Salmonellen und Aeromonaden im Vorfluter. GWF -- Wasser/Abwasser 112:401-403.

- Schubert, R.H.W. and Scheiber, P. (1975) Das Vorkommen von Pseudomonas aeruginosa im Grundwasser, Oberflächenwasser und in Wasserversorgungsleitungen in tropischen Gebieten. GWF -- Wasser/Abwasser 116:413-415.
- Schubert, R.H.W., Esanu, J., and Esanu, F. (1975) "Über den Abbau von Acetamid als taxonomisches Merkmal bei Species der Gattung Pseudomonas. Zbl. Bakt. Hyg., I. Abt. Orig. A 233:342-346.
- Schulze, H. and Schweisfurth, R. (1975) Eisenoxydierende stäbchenformige Bakterien. I. Untersuchungen unter Verwendung von Fe(II)-Oxalat im Medium. Z. Allg. Mikrobiol. 15:605-614.
- Schweisfurth, R. (1972) Manganoxydierende Mikroorganismen in Trinkwasserversorgungsanlagen. GWF -- Wasser/Abwasser 113:562-572.
- Schweisfurth, R. (1973) Manganoxydierende Bakterien. Literaturübersicht (Bestandsaufnahme beschriebener Arten), Zbl. Bakt. I. Ref. 233:257-270.
- Schweisfurth, R. (1974) Crenothrix polyspora Cohn as an indicator of organic pollution of groundwater. Proc. Soc. Ecol., pp. 161-165 (Edited by Muller, P. and Junk, W.) Erlangen.
- Schweisfurth, R. and Mertes, R. (1962) Mikrobiologische und chemische Untersuchungen über Bildung und Bekämpfung von Manganschlamm-Ablagerungen in einer Druckleitung für Talsperrenwasser. Arciv. für Hygien und Bakteriologie 146:401-417.
- Schweisfurth, R. and Ruf, A. (1976) Studies of the occurrence of methane-oxidizing bacteria in drinking water plants. GWF -- Wasser/Abwasser 117:313-318.
- Schweisfurth, R., Eleftheriadis, D., Gundlach, H., Jacobs, M. and Jung, W. (1978) Microbiology of the precipitation of manganese. In Environmental Biogeochemistry and Geomicrobiology, Vol. 3, pp. 923-928 (Edited by Krumbein, W.E.) Ann Arbor Science Publishers, Ann Arbor, Michigan.
- Scott, D.B.M. and Leshier, E.C. (1963) Effect of ozone on survival and permeability of E. coli. J. Bacteriol. 85:567-576.

- Sebald, M. and Veron, M. (1963) Annales de l'Institut Pasteur, Lille 105:897.
- Seidler, R.J., Morrow, J.E. and Bagley, S.T. (1977) Klebsiella in drinking water emanating from redwood tanks. Appl. Environ. Microbiol. 33:893-905.
- Seigneurin, R., Magnin, R., and Archard, M.L. (1955) Types d'Escherichia coli dans des eaux d'alimentation. Ann. Inst. Pasteur 89:473-474.
- Sepilli, L., Scassellati, R., Sforzolini, M. and Zavka, M. (1965) Prime osservazioni sulla possibilita di imbotigliamento di acque potabile in recipienti a perdere. Sanita Publ. 26:1133.
- Sepp, E. (1971) The use of sewage for irrigation. A literature review. State of California Department of Public Health, Bureau of Sanitary Engineering, pp. 1-41.
- Shaffer, P.T.B. (1978) Disinfectant resistant organisms, pp. 101-102. In Evaluation of the Microbiology Standards for Drinking Water (Edited by Hendricks, C.W.) EPA-570/9-78-00C.
- Sharp, D.G., Floyd, R. and Johnson, J.D. (1975) Nature of the surviving plaque-forming unit of reovirus in water containing bromine. Appl. Microbiol. 29:94-101.
- Shaw, P.K., Brodsky, R.E., Lyman, D.O., Wood, B.T., Hibler, C.P., Healy, G.R., Macleod, K.I.E., Stahl, W. and Schultz, M.G. (October 1977) A community-wide outbreak of giardiasis with evidence of transmission by a municipal water supply. Annals of Internal Med. 87:426-432.
- Shehabi, A. (1976) Bacteriological pollution in the drinking water of Jordan. Environmental Conservation 3:197-199.
- Sherry, J.P., Kuchma, S.R., Zarzour, J. and Dutka, B.J. (1979) Occurrence and significance of Candida albicans in Lake Ontario bathing beaches. Environment Canada Scientific Series No. 98. Inland waters Directorate, Burlington, Ontario, Canada.
- Shih, K.L. and Lederberg, J. (1976) Effects of chloramine on Bacillus subtilis deoxyribonucleic acid. J. Bacteriol. 125:934-945.

- Shillinger, J.E. and McFeters, G.A. (1978) Survival of Escherichia coli and Yersinia enterocolitica in stream and tap water. Abstracts of the Annual Meeting, Amer. Soc. for Microbiol. Abstract #79, American Society for Microbiol.
- Shotts, E.B. and Rimler, R. (1973) Medium for the isolation of Aeromonas hydrophila. Applied Microbiology 26:550-553.
- Shrewsbury, J.F.D. and Barson, G.J. (1952) Note on absolute viability in water of Salmonella typhi and dysentery bacilli. Brit. Med. J. I:954.
- Shuval, H.I. (editor) (1977) Water Renovation and Reuse. Academic Press, New York, San Francisco, London, 463 pages.
- Shuval, H.I. and Katzenelson, E. (1977) Detection and inactivation of enteric viruses in wastewater. Environmental Protect. Technol. Series EPA 600/2-77-095.
- Siders, D.L., Scarpino, P.V., Lucas, M., Berg, G. and Chang, S.L. (1973) Destruction of viruses and bacteria in water by monochloramine. Abstracts of the Annual Meeting Am. Soc. for Microbiol. (E 27).
- Silverman, M.P. and Munoz, E.F. (1979) Automated electrical impedance technique for rapid enumeration of fecal coliforms in effluents from sewage treatment plants. Appl. Environ. Microbiol. 37(3):521-526.
- Simard, R.E. and Blackwood, A.C. (1970) Yeasts from the St. Lawrence River. Canadian Journal of Microbiol. 17:197-203.
- Simudi, U., Ashino, K. and Kaneko, E. (1971) Bacterial flora of phyto- and zooplankton in the inshore water of Japan. Journal of Microbiol. 17:1157-1160.
- Singh, B.N. (1953) A new system of classifying amoeba based on their nuclear division and possible pylogenetic relationships. Symp. Organic Evolution, Bull. No. 7, pp. 178-183, National Inst. Sci. New Delhi, India.



- Singley, J.E., Kirchmer, C.J. and Miura, R. (1974) Analysis of coprostanol, an indicator of fecal contamination. Environmental Protection Technology Series. U.S. Environmental Protection Agency, Washington, D.C., EPA-660/2-74-021, 114 pages.
- Singley, J.E., Hoadley, A.W. and Hudson, H.E. (1975) A Benefit Cost Evaluation of Drinking Water Hygiene Problems, U.S. Environmental Protection Agency, NTIS Report No. PB 249-891, Washington, D.C.
- Skirrow, M.B. (1977) Campylobacter enteritis: A "new" disease. British Medical Journal 2:9-11.
- Slade, J.S. (1977) Enteroviruses in partially purified water. Journal Soc. Water Treatment Exam. 31:219-224.
- Sladek, K.J., Suslavich, R.V., Sohn, B.I. and Dawson, F.W. (1975) Optimum Membrane Structures for Growth of Coliform and Fecal Coliform Organisms. Appl. Microbiol. 30:685-691.
- Smibert, R.M. (1978) The genus Campylobacter. In Annual Review of Microbiology, Vol. 32, pp. 673-709 (Edited by Starr, M.P.) Annual Reviews Inc., Palo Alto, California.
- Smith, L.L. and Gouron, R.E. (1969) Sterol metabolism. VI. Detection of 5 -cholestan-3 -01 in polluted waters. Water Res. 3:141-148.
- Smith, L.L., Kohler, D.P., Hempel, J.E. and van Lier, J.E. (1968) Sterol metabolism. IV. Microbial disposition of 5 -cholestan-3 -01. Lipids 3:301-396.
- Smith, W.W. and Bodkin, R.E. (1944) The influence of hydrogen ion concentrations on the bactericidal action of ozone and chlorine. J. Bacteriol. 47:445-449.
- Snyder, J.E. and Chang, P.W. (1974) Relative resistance of eight human enteric viruses to ozonation in Saugatucket River water. In Aquatic Applications of Ozone (Proc. of workshop held in Boston, Massachusetts, 1974) International Ozone Institute (now Association) Cleveland, Ohio, pp. 29-42.

- Sobsey, M.D. (1976) Methods for detecting enteric viruses in water and wastewater. In Viruses in Water (Edited by Berg, G., Bodily, H.L., Lennette, E.H., Melnick, J.L. and Metcalf, T.G.) pp. 89-127, American Public Health Association, Washington, D.C.
- Soenke, H. (1974) Untersuchungen über bakterielle Indikatoren und deren Verhalten in Tafelwässern. Dissertation Freie Universität Berlin, Fachbereich Zahn-Mund und Kieferheilkunde (unpublished).
- Sohnngen, N.L. and Fol, J.G. (1914) The decomposition of India rubber by microbes. Centr. Bakteriöl. Parasitenk. 40:87-98.
- Sorber, C.A., Malina, J.F. and Sagik, B.P. (1972a) Virus rejection by the reverse osmosis ultrafiltration process, Water Res. 6:1377-1388.
- Sorber, C.A., Malina, J.F. and Sagik, B.P. (1972b) Quantitative procedure for evaluating the performance of water and wastewater processes at naturally occurring virus levels. Environ. Science & Technology 6:438-448.
- Sotelo-Avila, C., Taylor, F.M. and Ewing, C.W. (1947) Primary amoebic meningoencephalitis in a healthy 7-year-old boy. Journal of Pediatrics 85:131-136.
- Sphar, L.L. (1966) Microbiologic degradation of rubber gaskets in sanitary sewer service. J. Wat. Pollut. Control Fed. 38:641-644.
- Spino, D.F. (1966) Elevated temperature technique for the isolation of Salmonella from streams. Appl. Microbiol. 14:591-596.
- Stagg, C.H., Wallis, C. and Ward, C.H. (1977) Inactivation of clay-associated bacteriophage MS 2 by chlorine. Appl. Environ. Microbiol. 33:385-391.
- Steel, T.W. and McDermott, S. (1978) Campylobacter enteritis in South Australia. Medical Journal of Australia 2:404-406.
- Straskraba, M. and Straskrabová, V. (1969) Eastern European Lakes, pp. 65-97. In Eutrophication: Causes, Consequences, Corrections. Proceedings of a Symposium, Natl. Acad. Sci., Washington, D.C., 661 pages.

- Stringer, R.P., Cramer, W.M., and Kruse, C.W. (1975) Comparison of bromine, chlorine, and iodine as disinfectants for amoebic cysts, pp. 193-210. In Disinfection Water and Wastewater (Edited by Johnson, J.D.) Ann Arbor Sci., Ann Arbor, Mich.
- Strong, R.P. (1944) Stitt's Diagnosis, Prevention and Treatment of Tropical Diseases, 7th Edition. Blakiston Co., Philadelphia.
- Suchkov, B.P. (1964) Decontamination of drinking water containing agents which can cause intestinal diseases and enteroviruses by ozonation. Gig. i Sanit. 29:22-29.
- Sussman, S.J. and Rauh, J.E. (1978) Use of chlorine dioxide in water and wastewater treatment, pp. 344-355. In Ozone/Chlorine Dioxide Oxidation Products of Organic Materials (Edited by Rice, R.G. and Cotruvo, J.A.) International Ozone Institute, Inc., Cleveland, Ohio.
- Switzer-House, K.D. and Dutka, B.J. (1977) Fecal sterols: Their distribution in water and resultant significance. Water Pollution Res. Canada 13:175-182.
- Switzer-House, K.D. and Dutka, B.J. (1978) Fecal sterol studies: Sample processing and microbial degradation. Environment Canada Scientific Series, No. 89 N.W.R.I. Canada Centre for Inland Waters, Burlington, Ontario, Canada.
- Szmunn, W., and Prince, A.M. (1971) Epidemiologic patterns of viral hepatitis in Eastern Europe in light of recent findings concerning the serum hepatitis antigen. J. Infect. Dis. 123:200-212.
- Tabak, H.H., Bloomhuff, R.N. and Bunch, R.L. (1972) Coprostanol: A positive tracer of fecal pollution. In Development in Industrial Microbiology, Vol. 13, pp. 296-307. Publication of the Society for Industrial Microbiology, American Institute of Biological Science, Washington, D.C.
- Tabor, W.A. (1976) Wastewater microbiology. Ann. Rev. Microbiol. 30:263-277.
- Tan, L., Clemence, M. and Gass, J. (1970) Gas chromatographic analysis of fecal pollution sterols on a single combined packed column. J. Chromatogr. 53:209-215.

- Tannock, G.W. and Smith, J.M.B. (1971) Studies on the survival of Salmonella typhimurium and Salmonella bovismorbificans on pasture and water. Aust. Vet. J. 47:557-559.
- Taylor, F.B., Eagen, J.H., Smith, H.F.D. and Coene, J.F. (1966) The case for waterborne infectious hepatitis. American Journal of Public Health 56:2093-2105.
- Taylor, R.H. and Geldreich, E.E. (in press) Standard plate count methodology: A new membrane filter procedure for potable water and swimming pools. J. Am. Water Works Assoc., Denver, Colorado.
- Terney, O. (1973) Om kemolitotrofe bakterier. En sammenligning af kemolitotrofe bakteriers aktivitet i naturens kredsløbsprocesser. Report from the University of Copenhagen, Hygienic Institute, Copenhagen, 90 pages.
- Thames Water Statistics (1976) Vol. 2, p. E.2.1.
- Thaysen, A.C., Bunker, H.J. and Adams, M.E. (1945) Rubber acid damage in fire hoses. Nature, Lond. 155:323.
- Thornhill, T.S., Wyatt, R.G., Kalica, A.R., Dolin, R., Chanock, R.M. and Kapikian, A.Z. (1977) Detection by immune electron microscopy of 26-27-nm virus-like particles associated with two family outbreaks of gastroenteritis. J. of Inf. Dis. 135:20-27.
- Tobin, R.S. and Dutka, B.J. (1977) Comparison of the surface structure, metal binding and fecal coliform recoveries of nine membrane filters. Appl. Environ. Microbiol. 34:69-79.
- Tobin, R.S., Ryan, J.F. and Afghan, B.K. (1978) An improved method for the determination of adenosinetriphosphate in environmental samples. Water Research 12:783-792.
- Tolsma, D.D. and Bryan, J.A. (1976) The economic impact of viral hepatitis in the United States. Publ. Health Rep. 91:349-353.
- Toma, S. (1973) Survey on the incidence of Yersinia enterocolitica in the province of Ontario. Can. J. Public Health 64:477-487.

- Toma, S. and LaFleur, L. (1974) Survey on the incidence of Yersinia enterocolitica infection in Canada. Appl. Microbiol. 28:469-473.
- Tracy, H.W., Camarena, V.M. and Wing, F. (1966) Coliform persistence in highly chlorinated waters. J. Am. Water Wks. Ass. 58:1151-1159.
- Traenhart, O. and Kuwert, E. (1975) Vergleichende Untersuchungen über die Wirkung von Chlor und Ozon auf Polioviren bei der Trinkwasseraufbereitung der Stadt Essen. Zbl. Bakt. Hyg. I. Abt. Orig. B 160:305-341.
- Trakhtman, N.N. (1946) Chlorine dioxide in water disinfection. Gig. Sanit. 11:10-13.
- Trinel, P.A. and Leclerc, H. (1976) Essais de concentration de bacteries en suspension aqueuse par ultrafiltration. Ann. Microbiol., Inst. Pasteur 127B:201-212.
- Trinel, P.A. and Leclerc, H. (1977) Automatisation de l'analyse bactériologique de l'eau: Description d'une nouvelle méthode de colimétrie. Ann. Microbiol., Inst. Pasteur 128A:419-432.
- Turner, L.H. (1973) Leptospirosis. British Medical Journal 1:537-540.
- Ur, A. and Brown, D.F.J. (1974) Rapid detection of bacterial activity using impedance measurements. Biomed. Eng. 9:18-20.
- Ur, A. and Brown, D.F.J. (1975a) Monitoring of bacterial activity by impedance measurements. New Approaches to the Identification of Microorganisms (Edited by Heden, C.G. and Illeni, T.) pp. 61-71, John Wiley & Sons, Inc., New York.
- Ur, A. and Brown, D.F.J. (1975b) Impedance monitoring of bacterial activity. J. Med. Microbiol. 8:19-28.
- Vajdic, A.H. (1970) The isolation of virus (bacteriophage) from water and wastewater by millipore filter method, Water Management in Ontario (Ontario Water Resources Commission) 37:1-22.
- Van der Kooij, D. (1977) The occurrence of Pseudomonas sp. in surface water and in tap water as determined on citrate media. Antonie van Leeuwenhoek. 43:187-197.

- Van der Kooij, D. and Zoeteman, B.C.J. (1978) Water quality in distribution systems. Int. Wat: Supply Ass. Cong., Kyoto, Special subject 5.
- Van Dijck, P. and Van der Voorde, H. (1976) Sensitivity of environmental microorganisms to antimicrobial agents. Applied and Environmental Microbiol. 31:332-336.
- Van Donsel, D.J. and Geldreich, E.E. (1971) Relationships of Salmonella to fecal coliforms in bottom sediments. Water Res. 5:1079-1087.
- Van Donsel, D.J., Twedt, R.M. and Geldreich, E.E. (1969) Optimum temperature for quantitation of fecal coliform in seven hours on the membrane filter. Bacteriol. Proc. Abstract No. G46, 25, Am. Society for Microbiol., Washington, D.C.
- Van Uden, N. and Buckley, H. (1970) Candida Berkhout. In The Yeasts -- A Taxonomic Study, pp. 893-1087 (Edited by Lodder, J.) North-Holland, Amsterdam.
- Vaughn, J.M. and Metcalf, T.G. (1975) Coliphages as indicators of enteric viruses in shellfish and shellfish raising estuarine waters. Water Research 9:613-616.
- Venkobachar, D., Lyengar, L. and Rao, A.V. (1977) Mechanism of disinfection effect of chlorine on cell membrane functions. Water Research 11:727-729.
- Verstraete, W. and Voets, J.P. (1976) Comparative study of E. coli survival in two aquatic ecosystems. Water Res. 10:129-136.
- Victorin, K. and Stenström, T. (1975) Nitritbildning i vattenledningsvatten (Formation of nitrite in water distribution systems). Report: Statens Naturvårdsverk, Omgivning Omgivningshygieniska Avdelningen (Report, National Swedish Environment Protection Board Research Laboratory) Stockholm.
- Viswanathan, R. (1957) Infectious hepatitis in Delhi, 1955-1956: A critical study. I. Epidemiology. Ind. Journal of Medical Res., Supplementary Number, XLV, 1-29.
- Vlassoff, L.T. (1977) Klebsiella. In Bacterial Indicators/Health Hazards Associated with Water ASTM STP 635 (Edited by Hoadley, A.W. and Dutka, B.J.) Amer. Soc. for Testing and Materials, Philadelphia, Pennsylvania.

- Volker, H., Schweisfurth, R. and Hirsch, P. (1977) Morphology and ultrastructure of Crenothrix polyspora Cohn. J. Bacteriology 131:306-313.
- Vrochinskii, K.K. (1963) Experimental data on water decontamination with ozone. Hyg. Sanit. 28:3-9.
- Waksman, S.A. (1937) Associative and antagonistic effects of microorganisms. I. Historical review of antagonistic relationships. Soil Sci. 43:51-68.
- Wallis, C., Stagg, C.H., and Melnick, J.L. (1974) The hazards of incorporating charcoal filters into domestic water systems. Water Res. 8:111-113.
- Warren, Charles E. (1971) Biology and Water Pollution Control. W.B. Saunders Co., Philadelphia, 434 pages.
- Warriner, T.R. (1967) Inaktivering av poliovirus med klor-dioxid. Vatten 67:284-290.
- Watson, S.W., Novitsky, T.J., Quinby, H.L., and Valois, F.W. (1977) Determination of bacterial number and biomass in the marine environment. Appl. Environ. Microbiol. 33:940-946.
- Weidenkopf, S.J. (1958) Inactivation of type 1 poliomyelitis virus with chlorine. Virology 5:56-67.
- Wellings, F.M., Amuso, P.T., Chang, S.L. and Lewis, A.L. (1977) Isolation and identification of pathogenic Naegleria in Florida lakes. Applied and Environmental Microbiol. 34:661.
- Wellings, F.M., Lewis, A.L., Mountain, C.W. and Pierce, L. V. (1975) Demonstration of virus in groundwater after effluent discharge onto soil. Appl. Microbiol. 29:751-757.
- Werner, P. (1978) Mikrobiologische Untersuchungen des Wassers von Trinkwasser -- versorgungsanlagen unter besondere Berücksichtigung der Aktivkohlefiltration. Diplom-Arbeit, Universität des Saarlandes, Saarbrücken, FRG.
- Werner, P. (1979) Ökologisch-mikrobiologische Untersuchungen an Aktivkohlefiltern in Zusammenhang mit Trinkwasser-aufbereitung. Dissertationsarbeit, Universität des Saarlandes, Saarbrücken, FRG.

- Wenyon, C.M. (1947) Discussion on amoebiasis. Royal Soc. Trop. Med. Hyg. 41:35-39.
- White, G.C. (1972) Handbook of chlorination. Van Nostrand Reinhold Company Publishers, New York, 744 pages.
- Willis, A.T. (1956) Anaerobes as an index of faecal pollution in water. Journal of Applied Bacteriology 19:105-107.
- Willis, H.T. (1957) Anaerobic bacilli in a treated water supply. Journal of Applied Bacteriology 20:61-64.
- Wilson, G.S. and Miles, A. (1975) Topley and Wilson's Principles of Bacteriology, Virology and Immunity, 6th Edition. London, 2706 pages.
- Wilson, W.J. and Blair, E.M. (1925) Correlations of the sulphite-reduction test with other tests in the Bacteriological examination of water. J. Hyg. 24:111-119.
- Windle, Taylor E. (1947) Bacteriology of water samples from water mains. Journal of Applied Bacteriology 10:34-38.
- Windle, Taylor E. (1958) The Examination of Water and Water Supplies, 7th ed., Churchill, London.
- Winner, H.I. and Hurley, R. (1964) Candida albicans. Little, Brown, and Co., Boston.
- Woode, G.H., Bridger, J.C., Jones, J.M., Flewett, T.H., Bryden, A.S., Davies, H.A. and White, G.B.B. (1976) Morphological and antigenic relationships between viruses (rotaviruses) from acute gastroenteritis of children, calves, piglets, mice, and foals. Infection and Immunity 14:804-810.
- Woratz, H. and Bosse, G. (1968) The viability of Salmonellas in manganese and iron-containing slime in an urban water supply. Gesundhwes. Desinfekt. 60:97.
- World Health Organization (1977) Advances in Viral Hepatitis, Technical Report Series No. 602, Geneva, Switzerland.
- Wuhrmann, K. (1972) Stream purification. In Water Pollution Microbiology, pp. 119-151 (Edited by Mitchell, R.) John Wiley and Sons, New York.



- Wuhrmann, K. and Meyrath, J. (1955) The bactericidal action of ozone solution. Schweiz. A. Allgem. Pathol. Bakteriolog. 18:1060-1069.
- Wun, C.K., Walker, R.W. and Litsky, W. (1976) The use of XAD-2 resin for the analysis of coprostanol in water. Water. Res. 10:955-959.
- Wun, C.K., Walker, R.W. and Litsky, W. (1978) An improved polystyrene polymeric XAD-2 resin column extraction of 5 -cholestan-3 -ol from polluted water. Health Laboratory Science 15:67-73.
- Yoshimizu, M., Kamiyana, K., Kimura, T. and Sakai, M. (1976) Studies on the intestinal microflora of salmonids. IV. The intestinal microflora of freshwater salmon. Bulletin Jap. Soc. Sci. Fisch. 42:1281-1290.
- Zimmermann, R. (1977) Estimation of bacteria number and biomass by epifluorescence microscopy and scanning electron microscopy, pp. 103-120. In G. Rheinheimer (ed.) Microbial Ecology of a Brackish Water Environment. Springer-Verlag, Berlin, 291 pages.
- Zimmerman, R. and Meyer-Reil, L. (1974) A new method for fluorescence staining of bacterial populations on membrane filters. Keil. Merresforsch. 30:24-27.
- Zo Bell, C.E. and Grant, C.W. (1943) Bacterial utilization of low concentrations of organic matter. Journal of Bacteriol. 43:555-564.
- Zoeteman, B.C.J. (1972) The suitability of iodine and iodine compounds as disinfectants for small water supplies. Tech Paper No. 2. World Health Organization Intl. Ref. Centre for Community Water Supply. WHO File Ref. W2/181/2.
- Zwaagstra, J. (1978) Proeven met koolfilters in langzame zandfilters. Rapport PWN X.001.2"628.16. Provinciaal Waterleidingbedrijf van Noord-Holland, Bloemendaal, The Netherlands.
- Zwadyk, P. (1976) Vibrionaceae. In Zinsser Microbiology (Edited by Joklik, W.K. and Willett, H.P.) pp. 583-592, Appleton-Century-Crofts, New York, 1223 pages.

12

