

# Delivering Timely Air Quality, Traffic, and Weather Information to Your Community

## The Paso del Norte Environmental Monitoring Project

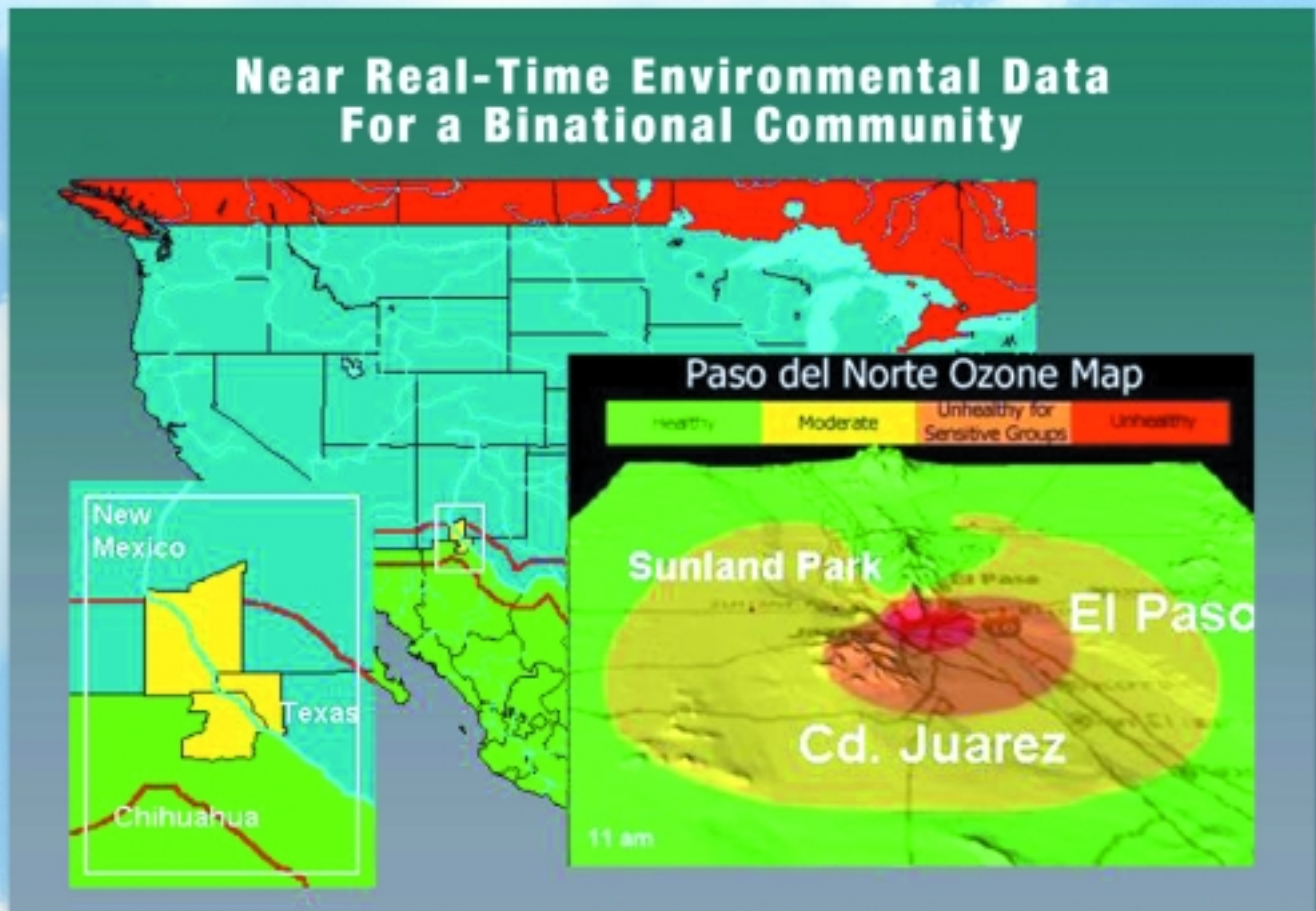

**E M P A C T**

Environmental Monitoring for Public Access  
& Community Tracking

**Disclaimer:** This document has been reviewed by the U.S. Environmental Protection Agency (EPA) and approved for publication. Mention of trade names or commercial products does not constitute endorsement or recommendation of their use.

# DELIVERING TIMELY AIR QUALITY, TRAFFIC, AND WEATHER INFORMATION TO YOUR COMMUNITY

## THE PASO DEL NORTE ENVIRONMENTAL MONITORING PROJECT

United States Environmental Protection Agency  
Office of Research and Development  
National Risk Management Research Laboratory  
Cincinnati, OH 45268



**50% Recycled/Recyclable**  
Printed with vegetable-based ink on  
paper that contains a minimum of  
50% post-consumer fiber content  
processed chlorine free

## ACKNOWLEDGMENTS

---

The development of this handbook was managed by Scott R. Hedges (U.S. Environmental Protection Agency, Office of Research and Development, National Risk Management Research Laboratory) with the support of Eastern Research Group, Inc., an EPA contractor. EPA would like to thank the following people and organizations for their substantial contributions to the contents of this handbook:

- Ricardo Dominguez, City of El Paso Metropolitan Planning Organization
- Salvador González-Ayala, Instituto Municipal de Investigación y Planeación, Ciudad Juárez, Chihuahua, Mexico
- Robert W. Gray, P.E., University of Texas at El Paso
- Chuck Koosian, City of El Paso, Texas
- City of El Paso Metropolitan Planning Organization, Transportation Policy Board
- Texas Commission on Environmental Quality
- El Paso City-County Health and Environment District
- New Mexico Environment Department
- Departamento de Ecología de Ciudad Juárez
- University of Texas at El Paso Center for Environmental Resource Management
- Universidad Autónoma de Ciudad Juárez

# CONTENTS

---

	Page
<b>CHAPTER 1 INTRODUCTION</b> .....	1-1
1.1 About the EMPACT Program .....	1-2
1.2 About the Paso del Norte Environmental Monitoring Project .....	1-2
1.3 About This Handbook .....	1-5
1.4 For More Information .....	1-6
<b>CHAPTER 2 HOW TO USE THIS HANDBOOK</b> .....	2-1
<b>CHAPTER 3 COLLECTING TIMELY ENVIRONMENTAL INFORMATION</b> .....	3-1
3.1 Air Quality Monitoring: An Overview .....	3-1
3.1.1 Design Factors for Air Quality Monitoring .....	3-2
3.1.2 Selecting Your Air Quality Monitoring Equipment and Locations .....	3-8
3.1.3 Installing, Operating, and Maintaining Air Quality Monitoring Equipment .....	3-10
3.2 Traffic Monitoring: An Overview .....	3-14
3.2.1 Design Factors for Traffic Monitoring .....	3-14
3.2.2 Selecting Your Traffic Monitoring Equipment and Locations .....	3-17
3.2.3 Installing, Operating, and Maintaining Traffic Monitoring Equipment ...	3-19
3.3 Collecting Weather Information .....	3-21
3.3.1 Weather Parameters .....	3-21
3.3.2 Sources of Information .....	3-22
3.4 Lessons-Learned From the Paso del Norte Environmental Monitoring Project ..	3-23
<b>CHAPTER 4 PROCESSING TIMELY ENVIRONMENTAL INFORMATION</b> .....	4-1
4.1 Processing Environmental Information: An Overview .....	4-1
4.2 Transferring Environmental Data to Your Central Hub .....	4-1
4.2.1 Data Transfer Components .....	4-2
4.2.2 Paso del Norte Project—Data Transfer Components .....	4-3
4.3 Managing Environmental Data .....	4-5
4.3.1 Formatting and Processing Data .....	4-6
4.3.2 Storing Data .....	4-7
4.3.3 Using Data in Models .....	4-7
4.4 Lessons Learned From the Paso del Norte Environmental Monitoring Project .....	4-8

<b>CHAPTER 5</b>	<b>DEPICTING TIMELY ENVIRONMENTAL INFORMATION</b> .....	<b>5-1</b>
5.1	What Is Data Visualization?.....	5-1
5.2	Data Visualization Tools Employed In the Paso del Norte Environmental Monitoring Project .....	5-2
5.2.1	Maps.....	5-2
5.2.2	Color Coding .....	5-3
5.2.3	Tables and Charts .....	5-4
5.2.4	Geographic Information System (GIS) .....	5-4
5.2.5	Live and Static Images.....	5-4
<b>CHAPTER 6</b>	<b>COMMUNICATING TIMELY ENVIRONMENTAL INFORMATION</b> .....	<b>6-1</b>
6.1	Creating an Outreach Plan for Near Real-Time Environmental Data .....	6-1
6.2	Elements of the Paso del Norte Environmental Monitoring Project Outreach Program .....	6-5
6.3	Resources for Presenting Environmental Information to the Public .....	6-8
<b>CHAPTER 7</b>	<b>COMMUNICATING TIMELY ENVIRONMENTAL INFORMATION</b> .....	<b>7-1</b>
7.1	Building on Existing Programs.....	7-1
7.2	Housing Your Database and Web Server .....	7-2
7.3	Public Support .....	7-2
7.4	What Data To Collect .....	7-2
<b>APPENDIX A</b> .....		<b>A-1</b>
	Case Study: Tucson, Arizona, Air Info Now Project .....	A-1
	Case Study: AirBeat Project of Roxbury, Massachusetts.....	A-5
<b>APPENDIX B</b> .....		<b>B-1</b>
	List of Useful Web Sites and References .....	B-1



# 1

## INTRODUCTION

---

Air in many United States cities is polluted by emissions from sources such as cars and trucks, power plants, and manufacturing processes. Air pollution can even come from everyday activities such as dry-cleaning clothes, filling your car with gas, and painting. When gases and particles from these activities accumulate in the air in high enough concentrations, they can harm human health and the environment. More people in cities and surrounding areas means more cars, trucks, and industrial and commercial operations, and generally means more air pollution. Often, terrain and meteorological conditions complicate air quality issues in an area.

Although the national trend is toward better outdoor air quality, there are some urban areas where improvement is not occurring. In those areas, the concentration of pollutants such as carbon monoxide (a product of incomplete combustion of fossil fuels), ground-level ozone, (formed by the chemical reaction of pollutants in the emissions from vehicles and other sources), and particulate matter (dry particles and liquid droplets emitted by sources such as vehicles, factories, and construction activities) in the air is increasing. Concentrations of outdoor air pollutants vary from day-to-day and even during the course of a day.

To protect their health, the public needs timely information on air quality and other factors (e.g., weather conditions) that affect air quality. Access to air quality forecasts allows residents to reduce their exposure when pollutant concentrations are high. This is important particularly to people who are sensitive to certain pollutants' harmful effects. For example, people with asthma may be sensitive to ground-level ozone and people with heart disease may be sensitive to carbon monoxide.

In 2000, a team of academic and government organizations launched a project to communicate timely environmental information to the public in the bi-national, tri-state metropolitan region that encompasses Ciudad (Cd.) Juárez, Mexico; El Paso County, Texas; and Doña County, New Mexico. This project, known as the Paso del Norte Environmental Monitoring Project, was funded with a grant from the U.S. Environmental Protection Agency's EMPACT Program. The project goals are to:

- Develop standards for sharing and displaying environmental information.
- Establish an infrastructure for communicating timely environmental information.
- Provide timely environmental information to the public and to the decision-makers in the Paso del Norte region.
- Improve coordination of environmental projects between various agencies, institutions, and organizations in the Paso del Norte region.
- Improve the public's understanding of individual actions that improve the environment.
- Educate future generations by providing opportunities for students to conduct research on and become involved in environmental issues.
- Share the project results with other regions in the country.

The Paso del Norte Project leveraged several existing efforts through which environmental information is collected in the Paso del Norte region. The collected information is transmitted to a central location, processed, and then communicated to the public through the Paso del Norte Project. Information collected through the leveraged efforts includes:

- Air pollutant concentration data (ozone, carbon monoxide, and particulate matter) collected by various agencies in Texas, New Mexico, and Mexico.
- Traffic volume data collected by the City of El Paso's Department of Traffic and Transportation and by the Texas Department of Transportation.
- International bridge crossing wait times provided by the U.S. Customs and Immigration Service. The Association of Maquilas also has developed an infrastructure to provide timely information on the number of bridge crossings and observed wait times.
- Static and live images from a webcam and video images of current traffic conditions at various locations in the Paso del Norte region.
- Weather data from the National Weather Service Web site.

This technology transfer handbook presents a case study on the Paso del Norte Project. It describes how the Paso del Norte Project started, how near real-time air quality, traffic, and weather data<sup>1</sup> are collected in the Paso del Norte region, how those data are processed and then communicated to the public, and presents lessons learned from the project. The handbook also provides readers with information on how to develop similar air quality, traffic, and weather monitoring, data processing, and outreach programs for their communities. The handbook is written primarily for community organizers, non-profit groups, local government officials, tribal officials, and other decision-makers who implement, or are considering implementing, environmental monitoring and outreach programs.

## **1.1 ABOUT THE EMPACT PROGRAM**

This handbook was developed by the U.S. Environmental Protection Agency (EPA) through their Environmental Monitoring for Public Access and Community Tracking (EMPACT) program. EPA created the EMPACT program to promote new and innovative approaches to collecting, managing, and communicating environmental information to the public. Working with communities across the country, the program takes advantage of new technologies to provide community members with timely, accurate, and understandable environmental information they can use to make informed, day-to-day decisions about their lives. EMPACT projects cover a wide range of environmental issues, including water quality, ground-water contamination, smog, ultraviolet radiation, and overall ecosystem quality. Some projects were initiated by EPA, while others were initiated by EMPACT communities themselves through EPA-funded Metro Grants.

## **1.2 ABOUT THE PASO DEL NORTE ENVIRONMENTAL MONITORING PROJECT**

El Paso is the dominant city in a larger metropolitan region generally referred to as Paso del Norte. This a bi-national, tri-state region that encompasses Cd. Juárez, Mexico; El Paso County, Texas; and Doña Ana County, New Mexico (see Figure 1). Its name originated in 1581 during the first Spanish Expedition. When the Conquistadors saw the fertile oasis in

---

<sup>1</sup>In this handbook, “near real-time” describes data collected and communicated to the public in a time frame that allows the public to use the data to make day-to-day decisions.



the vast Chihuahuan Desert between the Sierra de Juárez and the Franklin Mountains, they called it the “Pass of the North.” The population includes a mix of Spanish, Mexican, Indian, and American cultures. The Paso del Norte region is a major port of entry for north-bound trade and travel from Mexico. Centrally located along the 2,000-mile U.S.-Mexico border, it also is a major center for east–west transportation.



Figure 1. Location map of the Paso del Norte region.

The population of El Paso, which is located where the states of Texas, New Mexico, and Chihuahua meet, is more than 600,000. Elsewhere in El Paso County are Fort Bliss, the city of Socorro, and several other small cities and unincorporated communities. The total county population exceeds 700,000. Immediately south of El Paso and separated only by the narrow Rio Grande is Cd. Juárez, a city with an estimated population of 1,300,000. To the northwest is Sunland Park, New Mexico, a town with a population of approximately 10,000. The combined population of this region is projected to double within the next 25 years.

Cd. Juárez has led Mexico in industrial job growth over the past 10 years, and today Juárez is Mexico’s fourth largest city. The economies of Cd. Juárez and El Paso are interrelated, and the industrial boom in Cd. Juárez has generated a surge in El Paso’s population. The rapid growth has strained community infrastructures, significantly stressed the region’s natural resources, and exacerbated a number of the region’s environmental problems.

One of these environmental problems is air pollution. Terrain and the sun play major roles in concentrating air pollutants during stagnant conditions in the Paso del Norte region. Emissions from vehicles, industry, and urban areas also impact the concentration of air pollutants. Because the region contains multiple jurisdictions in two countries, making the public aware of the region's air quality problems and getting them involved in solving those problems is difficult. This is complicated by the need to communicate information to the public in both English and Spanish. Regardless of these seemingly overwhelming challenges, efforts of bi-national organizations (including the Paso del Norte Air Quality Task Force and the Joint Advisory Board) are helping to reduce exposure to unhealthy air quality conditions by reducing air emissions in the region. In fact, El Paso's air quality is showing signs of improvement to the point where options are being considered for the region to become an attainment area under the Clean Air Act.

### International Cooperation

In the Paso del Norte region, environmental data are collected in three different states in two countries. These include air quality data, traffic volume data, vehicle emissions data, international bridge crossing and wait time data, and weather data. Through the Paso del Norte Environmental Monitoring Project, these data are transferred to one database and processed for communication to the public in both English and Spanish.

The Paso del Norte Project empowers the public in the bi-national, tri-state metropolitan region that encompasses Cd. Juárez, Mexico; El Paso County, Texas; and Doña Ana County, New Mexico, by providing information they can use to help reduce air pollution in the region. This project could not have been done without the cooperation of many organizations, including the Instituto Municipal de Investigación y Planeación in Juárez, Mexico; the City of El Paso, Texas, Metropolitan Planning Organization; the Texas Commission on Environmental Quality; the New Mexico Environment Department; the El Paso City-County Health and Environment District; the Departamento de Ecología de Ciudad Juárez, the University of Texas at El Paso Center for Environmental Resource Management; and Universidad Autónoma de Ciudad Juárez.

The Paso del Norte Environmental Monitoring Project communicates critical environmental information for a region on the border between the United States and Mexico to the public in both countries. It serves as a prototype of international involvement and cooperation.

The City of El Paso is the lead agency for the Paso del Norte Environmental Monitoring Project. Partnering with the City of El Paso on this project are:

- University of Texas at El Paso.
- Texas Commission on Environmental Quality.
- El Paso City-County Health and Environment District.
- New Mexico Environment Department.
- Departamento de Ecología en Ciudad Juárez, Chihuahua, Mexico.

The support of these multiple agencies and institutions arose from official support for the Joint Advisory Committee (JAC), a bi-national organization that meets quarterly to review projects to improve regional air quality and make related recommendations. The JAC contains representatives of federal, state, and local governments; educational institutions; industry; and other groups. Its endorsement helps ensure cooperation and ongoing support from the many entities that must implement the Paso del Norte Project.

The scope of the Paso del Norte Environmental Monitoring Project, which began in January 2000, includes:

- Developing and implementing an automated system to transmit and process air quality data, traffic information (i.e., traffic counts and traffic conditions), border crossing information, international bridge wait times, and weather information to the public.
- Establishing a communications link so that daily near real-time traffic volume data can be input into existing transportation models for the region. The models can thus generate vehicle emissions estimates that correspond to the observed traffic volumes.
- Updating a current Web site by adding air quality information for particulate matter, traffic information, and weather information. The site now presents information on carbon monoxide and ozone.
- Purchasing computers for use in the Community Scholars Program, a pre-existing non-profit summer internship program for El Paso high school honor students.

Projects in which timely environmental information is transmitted and processed for communication to the public also are conducted in other communities in the United States. Two of those projects are the Air Info Now Project in Tucson, Arizona, and the AirBeat Project in Roxbury, Massachusetts. You may find Appendix A's information on these projects useful as you design and implement your environmental monitoring project.

### **1.3 ABOUT THIS HANDBOOK**

Several communities throughout the United States have expressed interest in initiating projects similar to the Paso del Norte Environmental Monitoring Project. The purpose of this handbook is to help interested communities and organizations learn more about the Paso del Norte Project and to provide them with the technical information they can use to develop their own programs. The Technology Transfer and Support Division of the EPA National Risk Management Research Laboratory (part of EPA's Office of Research and Development, or ORD) initiated the development of this handbook in collaboration with EPA's Office of Environmental Information. ORD, working with the Paso del Norte Project's partners, produced the handbook to leverage EMPACT's investment in the project and minimize the resources needed to implement similar projects in other areas.

Both the print and CD-ROM versions of the handbook are available for direct online ordering from ORD's Technology Transfer Web site at <http://www.epa.gov/ttnrmrl>. A PDF version of the handbook also can be downloaded from that site. In addition, you can order the handbook (print or CD-ROM version) by contacting ORD Publications by mail or telephone at:

**EPA ORD Publications**

26 W. Martin Luther King Dr.  
Cincinnati, Ohio 45268-001

EPA NSCEP toll free: 1-800-490-9198

EPA NSCEP local: 513-489-8190

Please make sure that you include the title of the handbook and the EPA document number in your request. We hope you find the handbook worthwhile, informative, and easy to use.

## 1.4 FOR MORE INFORMATION

Try the following resources for more information on the issues and programs this handbook discusses:

**EMPACT Program**

<http://www.epa.gov/empact/>

**Paso del Norte Environmental Monitoring Project**

<http://www.ozonemap.org>

**Air Quality Monitoring**

<http://www.epa.gov/airnow/cdmanual.pdf>

<http://www.epa.gov/ttn/amtic>

**Traffic Monitoring**

<http://www.fhwa.dot.gov>

# 2

## HOW TO USE THIS HANDBOOK

---

This handbook provides you with suggestions that may help you develop a program to provide timely environmental information to your community in an easily understandable format. Using the Paso del Norte Environmental Monitoring Project as a case study, the handbook contains information on how to:



- *Chapter 3* provides information on collecting timely environmental information. The chapter includes discussions of what air quality, traffic, and weather information to collect, and focuses on the environmental information collected in the Paso del Norte Environmental Monitoring Project.
- *Chapter 4* discusses how to transmit, store, retrieve, and analyze environmental information using automated equipment. The chapter focuses on how this was done in the Paso del Norte Environmental Monitoring Project.
- *Chapter 5* provides information on how to present environmental information in an understandable manner. It focuses on the data visualization tools used in the Paso del Norte Environmental Monitoring Project.
- *Chapter 6* outlines the steps involved in developing an outreach plan to communicate environmental information to your community. It also provides information about the Paso del Norte Project's outreach efforts. In addition, the chapter contains a list of resources that can help you develop easily understandable materials to communicate environmental information to a variety of audiences.
- *Chapter 7* discusses how the collection of near real-time environmental data can be sustained over time. It discusses how to build on existing programs, housing of databases and Web servers, public support for environmental monitoring, and the information that can be collected with respect to the availability of funds.

This handbook is designed for decision-makers considering whether to implement a near real-time environmental monitoring program in their communities and for technicians responsible for implementing these programs. Managers and decision-makers likely will find the initial general discussions and sections of Chapters 3, 4, 5, and 6 most helpful. The discussions in the latter sections of these chapters, which are targeted primarily for professionals and technicians, provide detailed “how to” information. Chapter 7 is designed for managers.

The handbook also refers you to supplementary sources of information, such as Web sites and guidance documents, where you can find additional guidance with a greater level of technical detail. Appendix B includes a list of Web sites and resources you may find helpful in developing an environmental monitoring program. Interspersed throughout the handbook are text boxes that describe some of the lessons learned by the Paso del Norte Project Team in developing and implementing its data transfer, data management, and outreach programs.

# 3 COLLECTING TIMELY ENVIRONMENTAL INFORMATION

---

This chapter provides information about collecting timely environmental information—the first step in generating information about the environment and making the information available to the public. *Near real-time* environmental data are collected and communicated to the public in a time frame that allows the public to use the data in making day-to-day decisions impacted by environmental conditions. They also can be used to see changes over time in the values for the parameters measured.

This chapter begins with a general overview of air quality monitoring in Section 3.1, including a discussion of factors to consider when selecting the parameters to monitor and the monitoring frequency for those factors, as well as a discussion of the selection, installation, operation, and maintenance of air quality monitors. It concludes with a discussion of air quality monitoring in the Paso del Norte Project. Section 3.2 provides a general overview of collecting traffic data. It discusses locating traffic monitors, frequency of monitoring, selecting monitoring equipment, and the installation, operation, and maintenance of traffic monitoring equipment. Traffic monitoring conducted as part of the Paso del Norte Project also is discussed in this section. Section 3.3 reviews collection of weather information.

As mentioned previously, the Paso del Norte Environmental Monitoring Project leverages several existing programs. Air quality data are collected through existing continuous air monitoring stations, (CAMS), traffic monitoring data are collected using existing traffic sensors, and weather data are obtained from the National Weather Service. Collected data are processed and communicated to the public through the Paso del Norte Project.

Readers primarily interested in an overview of environmental monitoring might want to focus on the introductory information in Sections 3.1, 3.2, and 3.3. If you are responsible for the actual design and implementation of a monitoring project, you should review all of the information in those sections. They introduce the specific steps involved in developing and operating a remote near real-time environmental monitoring project and explain where to find additional guidance. Throughout the chapter, decisions made for the Paso del Norte Environmental Monitoring Project are discussed.

## 3.1 AIR QUALITY MONITORING: AN OVERVIEW

The Clean Air Act (CAA) is the comprehensive federal law that regulates air emissions in the United States. Among other things, the CAA requires EPA to set standards for “criteria pollutants”—six commonly occurring air pollutants, including ground-level ozone, carbon monoxide, and particulate matter. These standards, known as the National Ambient Air Quality Standards (NAAQS), are national targets for acceptable air concentrations of each of the criteria pollutants. For each pollutant, EPA develops two NAAQS:

- The “primary standard,” which protects public health.
- The “secondary standard,” which prevents damage to the environment and property.

A geographic area that meets the primary health-based NAAQS is called an attainment area. Areas that do not meet the primary standard are non-attainment areas. More information about the CAA (including the full text of the Act and a Plain English Guide to the Act) can be found at <http://www.epa.gov/epahome/laws.htm>.



The CAA requires each state to develop a State Implementation Plan (SIP). A SIP describes the programs a state uses to maintain good air quality in attainment areas and meet the NAAQS in non-attainment areas. For example, if a city or region is a non-attainment area for carbon monoxide, the SIP describes the programs used to meet the NAAQS for carbon monoxide. In the Paso del Norte Region, El Paso County, Texas, is a non-attainment area for ozone, carbon monoxide, and particulate matter, and two areas in southern Doña Ana County, New Mexico, are non-attainment areas for ozone and particulate matter.

An air monitoring network is an air surveillance system consisting of monitoring stations that measure ambient air concentrations of pollutants. Data from these stations are used to determine whether the NAAQS for a pollutant is met. For more information on air quality monitoring (e.g., information on air quality monitoring methods and technical articles on air quality monitoring), access the Technology Transfer Network (TTN) Web site of EPA's Office of Air and Radiation (<http://www.epa.gov/ttn/amtic/>).

One of the tools that EPA uses to evaluate air quality is an Air Quality Index (AQI). This index tells you how clean or polluted the air is based on a scale of 0 to 500, and is based on health effects that can happen within a few hours or days after breathing polluted air. EPA uses the AQI to gauge air quality with respect to five of the six air pollutants regulated by the CAA: ground-level ozone, particulate matter, carbon monoxide, sulfur dioxide, and nitrogen dioxide (see the box on page 3-3). More information on the AQI is available in Chapter 6 of this manual and on EPA's AirNow Web site (<http://www.epa.gov/airnow/>).

### **3.1.1 DESIGN FACTORS FOR AIR QUALITY MONITORING**

To design your air monitoring program, you must first identify the purpose of the monitoring. Your reasons may be one or more of the following:

- To improve public awareness of air pollution, reduce health risks from air pollution, or develop ways to reduce air pollution.
- To identify current and potential air pollution problems.
- To monitor trends or changes in air quality.
- To gather information for the design of pollution prevention or restoration projects.
- To monitor pollution reduction activities and determine if the goals of specific programs are being met.
- To develop emergency response plans for accidental emission releases.

The main purpose of air quality monitoring in the Paso del Norte region is to collect ground-level ozone, carbon monoxide, and particulate matter data.

After you identify the purpose of your air quality monitoring program, consider the following factors in designing the program:

- What area do you want to include in the program?
- Are there already air monitors in place?
- What air pollution sources are in your area?
- Which parameters should you measure?
- How often should you measure the parameters?

## Criteria Air Pollutants

**Ozone.** Ozone is a secondary pollutant formed in the atmosphere by reactions between oxides of nitrogen (NO<sup>x</sup>) and volatile organic compounds (VOCs). Depending on the area, ozone generation may be limited by the concentration of either NO<sup>x</sup> or VOCs in the atmosphere. Warm, dry, and cloudless days with low wind speeds are most conducive to ozone formation; these conditions most often occur during high-pressure weather systems.

**Particulate Matter (PM).** The term “particulate matter” includes both solid particles and liquid droplets found in air. Many man-made and natural sources emit PM directly or emit other pollutants that react in the atmosphere to form PM. These solid and liquid particles come in a wide range of sizes. Particles less than 10 micrometers in diameter (PM<sub>10</sub>) tend to pose the greatest health concern because they can be inhaled into and accumulate in the respiratory system. Particles less than 2.5 micrometers in diameter (PM<sub>2.5</sub>) are referred to as “fine” particles. Sources of fine particles include all types of combustion processes (e.g., power plants) and some industrial processes. Particles with diameters between 2.5 and 10 micrometers are referred to as “coarse.” Sources of coarse particles include grinding operations and dust from paved or unpaved roads.

**Carbon monoxide (CO).** Carbon monoxide is an odorless, colorless gas. It forms when the carbon in fuels does not completely burn. Vehicle exhaust contributes roughly 60 percent of all carbon monoxide emissions nationwide, and up to 95 percent in cities. Carbon monoxide concentrations typically are highest during cold weather because combustion is less complete in cold temperatures.

**Sulfur Dioxide (SO<sub>2</sub>).** Sulfur dioxide is a colorless, reactive gas produced during the burning of sulfur-containing fuels such as coal and oil. Major sources include power plants and industrial boilers.

**Nitrogen Dioxide (NO<sub>2</sub>).** Nitrogen dioxide is a reddish brown, highly reactive gas formed when nitric oxide combines with oxygen in the atmosphere. Once it forms, nitrogen dioxide reacts with other pollutants (volatile organic compounds). Eventually these reactions result in the formation of ground-level ozone. Major sources of NO<sub>2</sub> include automobiles and power plants.

**Lead.** Lead is a metal found naturally in the environment as well as in manufactured products. The major sources of lead emissions historically are motor vehicles and industrial sources. Because of the phase-out of leaded gasoline, metal processing is now the major source of lead emissions. The highest air concentrations of lead generally are found near lead smelters. Other stationary sources include waste incinerators, utilities, and lead-acid battery manufacturers. Exposure to lead can adversely affect humans (e.g., cause damage to kidneys and the liver) as well as animals and fish.

### WHAT AREA DO YOU WANT TO INCLUDE IN THE PROGRAM?

You might determine the area you wish to cover according to your organization’s jurisdiction. You also may decide to collect air quality data in multiple jurisdictions to ensure that an entire region is covered.

In the Paso del Norte region, several communities in two countries form a single metropolitan area, sharing an “air basin” in the valley created by the Rio Grande between the Franklin Mountains and the Sierra de Juárez. This common air basin is subject to inversions that trap pollutants in the cooler air along the valley floor during the morning hours (see Figure 2). Air quality data are collected in each jurisdiction and used to inform the public about air quality in the region.

### ARE THERE ALREADY AIR MONITORS IN PLACE?

Many agencies and organizations conduct air quality monitoring, including state pollution control agencies, Indian tribes, city and county environmental offices, EPA and other federal agencies, and private entities, such as universities, environmental organizations, and industries. By working with organizations currently collecting air quality data, you might be able to cover a larger area with less funds when you develop your near real-time air quality monitoring program.



Figure 2. Inversion in the Paso del Norte region.

The Paso del Norte Project gets air quality data from 25 existing CAMS in El Paso County, Texas; Doña Ana County, New Mexico; and Cd Juárez, Mexico. Figure 3 below shows the locations of the monitoring stations. Some of these monitors had to be upgraded to collect near real-time carbon monoxide and particulate matter data.

### WHAT AIR POLLUTION SOURCES ARE IN YOUR AREA?

You may determine your air monitoring needs based on the sources of air emissions. In an urban setting, vehicle emissions may contribute most of the air pollution. In a more rural setting, emissions from local industries may contribute significantly to the air pollution. If you are limited in the number of pollutants that you can monitor, monitor the pollutants that have the greatest effect on air quality in your area.

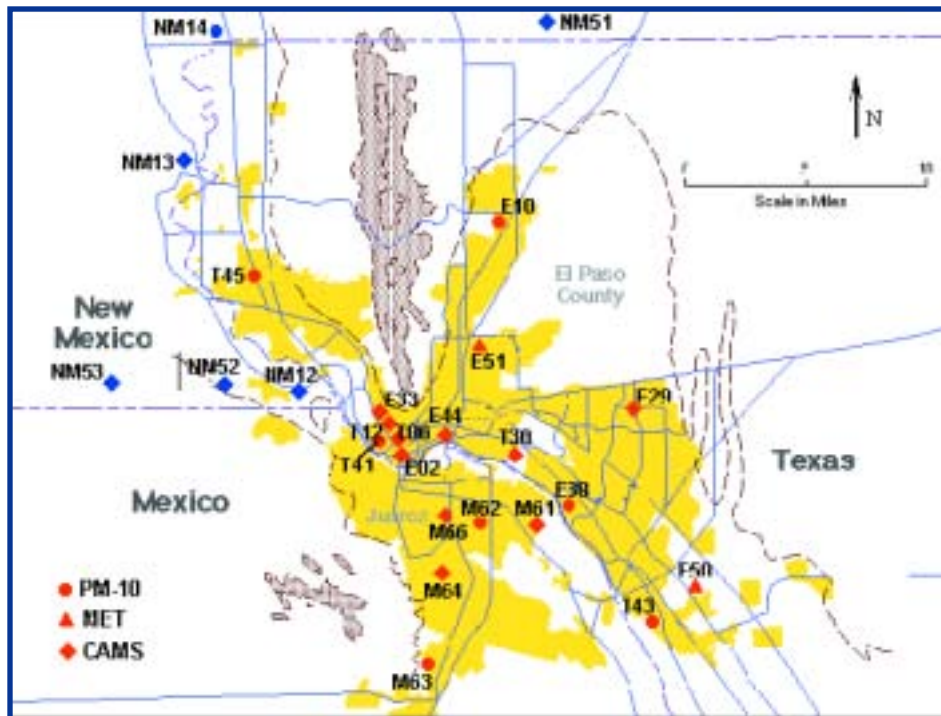

Figure 3. Location of continuous air monitoring stations.

While brick kilns, unpaved streets, automobile paint shops, and scrap materials used for home heating and cooking are significant contributors to air pollution in the Paso del Norte region, the major source of air pollution is vehicle emissions. The impact of vehicle emissions on air quality is made worse by the fact that vehicle emission inspections are not required in Mexico. Thus, vehicles in Cd. Juárez with high emissions are not identified and repaired.

### WHICH PARAMETERS SHOULD YOU MEASURE?

Parameters that you measure in your air quality monitoring program may depend on the air quality situation in your area. For example, EPA has designated portions of the Paso del Norte region as non-attainment area for ground-level ozone, carbon monoxide, and particulate matter. In addition, based on U.S. air quality standards,<sup>2</sup> a large portion of the densely inhabited core of Cd. Juárez is impacted by ground-level ozone, carbon monoxide, and particulate matter. For these reasons, ground-level ozone, carbon monoxide, and particulate matter are the air pollutants of concern in the region. Pollutants for which data are collected at each of the CAMS in the Paso del Norte Region are listed below.

Monitoring Station	Air Parameters	Meteorological Parameters
<b>Texas Monitoring Stations</b>		
El Paso Downtown C6 (EPA Site #48-141-0027)	Carbon monoxide (CO)	Wind speed Resultant wind speed Resultant wind direction Maximum wind gust Standard deviation of horizontal wind direction Outdoor temperature
El Paso UTEP C12/C125/C151 (EPA Site #48-141-0037)	CO Nitric oxide (NO) Nitric dioxide (NO <sub>2</sub> ) Oxides of nitrogen (NO <sub>x</sub> ) Ozone PM <sub>10</sub> (standard conditions) PM <sub>2.5</sub> (local conditions) Sulfur dioxide (SO <sub>2</sub> )	Wind speed Resultant wind speed Resultant wind direction Maximum wind gust Standard deviation of horizontal wind direction Outdoor temperature Dew point temperature Relative humidity Solar radiation Ultraviolet radiation
Ascarate Park Southeast C37/C159/C172 (EPA Site #48-141-0055)	CO NO NO <sub>2</sub> NO <sub>x</sub> Ozone PM <sub>10</sub> (standard conditions)	Wind speed Resultant wind speed Resultant wind direction Maximum wind gust Standard deviation of horizontal wind direction Outdoor temperature Dew point temperature Relative humidity Visibility Solar radiation Barometric pressure
El Paso Sun Metro C40/C116 (EPA Site #48-141-0053)	CO PM <sub>2.5</sub> (local conditions) SO <sub>2</sub>	Wind speed Resultant wind speed Resultant wind direction Maximum wind gust Standard deviation of horizontal wind direction Outdoor temperature

...continued on next page.

<sup>2</sup> Except for Mexico City, Mexico does not have air quality standards for ground-level ozone, carbon monoxide, and particulate matter.

Monitoring Station	Air Parameters	
Chamizal C41/C126 (EPA Site #48-141-0044)	CO NO NO <sub>2</sub> NO <sub>x</sub> Ozone	
Socorro C49 (EPA Site #48-141-0057)	NO NO <sub>2</sub> NO <sub>x</sub> Ozone	Wind speed Resultant wind speed Resultant wind direction Maximum wind gust Standard deviation of horizontal wind direction Outdoor temperature
Skyline Park C72 (EPA Site #48-141-0058)	CO NO NO <sub>2</sub> NO <sub>x</sub> Ozone SO <sub>2</sub>	Wind speed Resultant wind speed Resultant wind direction Maximum wind gust Standard deviation of horizontal wind direction Outdoor temperature
Tillman C413 (EPA Site #48-141-0002)	CO	Wind speed Resultant wind speed Resultant wind direction Maximum wind gust Standard deviation of horizontal wind direction
Ivanhoe C414 (EPA Site #48-141-0029)	CO Ozone	Wind speed Resultant wind speed Resultant wind direction Maximum wind gust Standard deviation of horizontal wind direction Outdoor temperature Relative humidity
Northeast Clinic (EPA Site #48-141-0010)	PM <sub>10</sub> PM <sub>2.5</sub>	None
Riverside High School (EPA Site #48-141-0038)	PM <sub>10</sub> PM <sub>2.5</sub>	None
Vilas School (EPA Site #48-141-0041)	PM <sub>10</sub>	None
Escontrias School (EPA Site #48-141-0043)	PM <sub>10</sub>	None
Lindberg School (EPA Site #48-141-0045)	PM <sub>10</sub>	None
<b>New Mexico Monitoring Stations</b>		
Sunland (NM12) (EPA Site #35-013-0017)	Ozone SO <sub>2</sub>	2-meter aspirated temperature 10-meter aspirated temperature Total solar radiation Wind speed Wind direction Standard deviation of wind direction
La Union (NM13)	Ozone SO <sub>2</sub>	2-meter aspirated temperature 10-meter aspirated temperature Total solar radiation Wind speed Wind direction Standard deviation of wind direction

...continued on next page.



Monitoring Station	Air Parameters	Meteorological Parameters
Anthony (NM14) (EPA Site #35-013-0019)	PM <sub>10</sub>	2-meter aspirated temperature 10-meter aspirated temperature Total solar radiation Wind speed Wind direction Standard deviation of wind direction
Chaparral (NM51) (EPA Site #35-013-0020)	NO <sub>x</sub> Ozone	2-meter aspirated temperature 10-meter aspirated temperature Total solar radiation Wind speed Wind direction Standard deviation of wind direction
Desert View (NM52) (EPA Site #35-013-0021)	NO <sub>x</sub> Ozone	2-meter aspirated temperature 10-meter aspirated temperature Total solar radiation Wind speed Wind direction Standard deviation of wind direction
Santa Teresa (NM53) (EPA Site #35-013-0022)	NO <sub>x</sub> Ozone	2-meter aspirated temperature 10-meter aspirated temperature Total solar radiation Wind speed Wind direction Standard deviation of wind direction
<b>Cd. Juárez, Mexico, Monitoring Stations</b>		
Tec de Monterrey (AIRS ID 80-0060-001)	CO Ozone PM <sub>10</sub>	None
Pestalozzi (AIRS ID 80-0060-002)	PM <sub>10</sub>	None
Zenco Plant (AIRS ID 80-0060-001)	PM <sub>10</sub>	None
Advance Transformer (AIRS ID 80-0070-004)	CO Ozone PM <sub>10</sub>	None
20/30 Club (AIRS ID 80-0060-006)	CO Ozone PM <sub>10</sub>	None

After you have selected your air quality parameters, you need to determine the method used to analyze a sample for those parameters. EPA provides technical guidance on analytical methods for air pollutants. You can find information on air analytical methods on the Office of Air and Radiation's TTN Web site (<http://www.epa.gov/ttn/amtic/>).

Air quality data for carbon monoxide, ground-level ozone, and particulate matter are collected in the Paso del Norte region because certain areas in the region are non-attainment areas for those pollutants.

### HOW OFTEN SHOULD YOU MEASURE FOR CERTAIN PARAMETERS?

Because the public uses near real-time air quality data to help select their daily activities, you need to collect enough data to report daily trends. Your frequency of monitoring depends on the kind of air monitoring you do. You can conduct several kinds of air quality monitoring:

- At fixed locations on a continuous basis.
- At selected locations on an as-needed basis or to answer specific questions.



- On a temporary or seasonal basis (such as during the summer).
- On an emergency basis.

For the Paso del Norte Project, air quality data are collected every 5 minutes at 25 fixed locations around the region (see Figure 3). Fourteen of the monitoring locations are in El Paso, six are in New Mexico, and five are in Cd. Juárez, Mexico.

### 3.1.2 SELECTING YOUR AIR QUALITY MONITORING EQUIPMENT AND LOCATIONS

The type of air quality monitoring that you do, the monitoring equipment you select, and the locations of the monitors depend on your project's objectives. Monitoring either can be done continuously or for a discrete period. When the operator retrieves and analyzes data collected at a location different from the monitoring site itself, the monitoring is called remote. This section discusses the equipment needed for continuous air monitoring and the location of the air monitoring equipment.

#### CONTINUOUS AIR MONITORING EQUIPMENT

Equipment needed to perform continuous air monitoring includes a sampler, an analyzer, a calibration unit, and a data logger. Data can be downloaded from the data loggers to an offsite computer through a modem connection. To do this, data acquisition and processing software and a data storage module are needed. For information on selecting monitoring equipment, go to <http://www.epa.gov/airnow/cdmanual.pdf>.

Of the 14 CAMS in the Paso del Norte region that are located in Texas, 8 have a CO monitor, 6 have an ozone monitor, and 8 have a particulate matter monitor. The manufacturers and model numbers for the monitors are:

- CO monitor—TECO Model 48 (monitors operated by the Texas Commission on Environmental Quality) and Dasibi Model 3008 (monitors operated by the El Paso City-County Health Management District).
- Ozone monitor—Dasibi Models 1003-AH/1008-AH.
- PM<sub>10</sub>/PM<sub>2.5</sub>—TEOM Model 1400a.

All of the CAMS in Texas have Dasibi 5008 calibration units and Zeno 3200 data loggers.

The three CAMS in Mexico that measure CO and ozone have Dasibi Model 3008 CO monitors and Dasibi 1003-AH ozone monitors. Wedding PM<sub>10</sub> monitors, Dasibi 5008 calibration units, and Zeno 3200 data loggers are used in all five of the Mexico CAMS.

Four of the CAMS in New Mexico have the Thermo 49 ozone monitor and one has a Dasibi Model 1003-PC ozone monitor. Three of the CAMS have TEOM PM<sub>10</sub> monitors and four have TEOM PM<sub>2.5</sub> monitors. CO is not monitored at the New Mexico CAMS. Three of the CAMS have Thermo 146 gas calibrators, and the Columbia Scientific Instruments Model 1700 gas calibrator and Dasibi 1008 ozone transfer standards are used for manual calibration at the other two CAMS where ozone is monitored. Five of the CAMS have Campbell Scientific, Inc., Model 21X data loggers, and one has a Campbell Scientific, Inc., Model 23X data logger.

## Air Monitoring Equipment

**Sampler.** The probe used to extract a sample of a pollutant from the atmosphere must be made of suitable material. Initially, it is inert. With use, reactive particulate matter may be deposited on the probe walls. This may affect the probe residence time (i.e., the time it takes for the sample gas to transfer from the inlet of the probe to the analyzer). For this reason, the condition of the probe should be checked frequently.

**Analyzers.** An air quality analyzer measures the concentration of a pollutant in a sample of ambient air. An analyzer should meet the reference method or equivalent method requirements specified by EPA to help ensure that air quality measurements are accurate. EPA maintains a current list of all designated reference and equivalent methods at the Ambient Monitoring Technology Information Center (AMTIC) Bulletin Board located online at <http://www.epa.gov/ttn/amtic/>.

Before you purchase an analyzer, you should verify that it meets the reference method or equivalent method requirements. Because manufacturers change or modify analyzers without changing their model numbers, the model number alone does not necessarily indicate that an analyzer meets the method requirements.

**Calibration units.** Calibration determines the relationship between the observed and the true values of a measured parameter. Accuracy is the extent to which measurements represent their corresponding actual values, and precision is a measurement of the variability observed over repeated analyses. The accuracy and precision of data derived from air monitoring instruments depend on sound instrument calibration procedures.

**Data loggers.** The analyzers at your monitoring site generate data that must be recorded and reported. A data logger is a computerized system used to control and record data.

With a data logger, you can interact with software using either a keyboard or an interactive, command-oriented interface. Data loggers perform the following functions:

- Review collected data.
- Produce printed reports.
- Control the analyzer and other instruments.
- Set up instrument operating parameters.
- Perform diagnostic checks.
- Set up external events and alarms.
- Define external storage.

## MONITORING LOCATIONS

You should select monitoring locations that best fulfill the objectives of your remote near real-time air quality monitoring project. Consider the questions below when choosing your monitoring location.

### Monitoring Location Checklist

- Are the data you collect at these locations likely to fulfill your project’s objectives? Specifically, what questions can you answer with your data, and how will the answers help you to fulfill your objectives?
- Do people in your community support equipment installation and remote near real-time monitoring at your locations?
- Does the monitoring equipment at your location pose a potential danger to the people in your community? For example, are your monitoring locations near a heavily trafficked area?
- Is the monitoring equipment safe at your locations? For example, is the equipment susceptible to vandalism or tampering?
- What local, state, or federal regulations do you need to consider when choosing your locations?
- Is flexibility important to your project? Would you like the option to move your monitoring equipment to different locations, or would you like to monitor at several locations concurrently?
- Do you foresee any site-specific problems with installing, operating, and maintaining your monitoring equipment at these locations? Do these locations pose any safety hazards to your personnel?
- Can you adequately survey and access your locations? What equipment-specific considerations will you need to make?

### 3.1.3 INSTALLING, OPERATING, AND MAINTAINING AIR QUALITY MONITORING EQUIPMENT

After you have completed the planning activities for your air quality monitoring program (i.e., selecting monitoring equipment and monitoring locations), the next step is to install the monitoring equipment. When you install your equipment, always consider how you will operate and maintain the equipment (e.g., is it easily accessible for maintenance?).

#### INSTALLING AIR QUALITY MONITORS

When you install your air monitoring equipment, always consult the equipment manufacturer’s manual for any special installation instructions. You also need to control any physical influences that might affect sample stability, chemical reactions within the sampler, and the function of sampler components when you install the equipment. This helps ensure that you receive accurate data from your monitoring station. The table below summarizes physical influences and the ways in which you can control them.

Variable	Method of Control
Instrument vibration	Design instrument housings and benches according to manufacturer’s specifications. Use shock-absorbing feet for the sampler and a foam pad under the analyzer. Attempt to find and isolate the source of the vibration. The pumps themselves can be fitted with foam or rubber feet to reduce vibration. If the pumps are downstream of the instruments, connect the pumps using tubing that prevents the transfer of vibrations back to the instruments and instrument rack.
Light	Shield instrumentation from natural or artificial light.
Electrical voltage	Ensure constant voltage to transformers or regulators. Separate power lines. Isolate high-current equipment such as heating baths and pumps on their circuits. Check the total amps drawn should be checked before adding another instrument.
Temperature	Regulate the air-conditioning system. Use a 24-hour temperature recorder. Use electrical heating/cooling only.
Humidity	Regulate the air-conditioning system. Use a 24-hour recorder.

Your monitoring equipment needs to operate unattended for prolonged periods. Standard security measures such as enclosures, fences, and lighting help safeguard the equipment and prevent interference with equipment operation. To enclose monitoring equipment, you might construct a shelter or use a trailer with appropriate power, telephone, and air conditioning systems.

Before operating new equipment, you need to assemble the system and perform testing. An initial calibration also must be performed.

As previously mentioned, air quality data for the Paso del Norte region are collected in 25 CAMS. These existed when the Paso del Norte Environmental Monitoring Project was initiated. The locations of the CAMS and the pollutants monitored at each CAMS are listed above.

### **OPERATING AIR QUALITY MONITORS**

After you install your air quality monitors, you should develop written standard operating procedures (SOPs) that describe the operation of each part of the monitoring station. Be sure to develop written SOPs for a repetitive or routine procedure that significantly affects data quality. Information about developing, documenting, and improving SOPs can be found in *Guidance for the Preparation of Standard Operating Procedures for Quality-Related Documents* (EPA/600/R-96/027). To locate this document, search EPA's Web site for documents by publication number (<http://www.epa.gov/clariton/clhtml/pubtitle.html>).

You should also conduct quality assurance/quality control (QA/QC) checks on your monitoring equipment to ensure that it functions properly. See the box below for a discussion of these checks.

#### **Quality Assurance and Quality Control**

Data validation entails accepting or rejecting monitoring data based on routine periodic analyzer checks. For example, you need to check the analyzer span for excessive drift. If the span drift is equal to or greater than 25 percent, data are invalid. If this is the case and you only perform span checks at the minimum recommended frequency of once every 2 weeks, up to 2 weeks of monitoring data may be invalid. To avoid this situation, you might want to perform span checks more often.

You should analyze the hard copy output from the data logger to detect signs of malfunctions, including:

- A straight trace (other than the minimum detectable) for several hours.
- Excessive noise (noisy outputs may occur when analyzers are exposed to vibrations).
- A long, steady increase or decrease in deflection.
- A cyclic trace pattern with a definite time period, indicating a sensitivity to changes in temperature or other parameters.
- A trace below the zero baseline that may indicate a larger than normal drop in ambient room temperature or power line voltage.
- Span drift equal to or greater than 25 percent.

Data must be voided for any time interval during which the analyzer malfunctions.

In addition, the integrity of air samples may be compromised by faulty delivery systems such as the sampling interface. For information about QA/QC protocols set forth by EPA, refer to AMTIC's QA/QC Web site (<http://www.epa.gov/ttn/amtic/qaqc.html>).

A typical ambient air quality monitoring station is shown in Figure 4. A constant-speed vacuum pump draws air into a glass manifold inside the monitoring station. As the air flows through the manifold, a portion goes through a sample line filter and then through Teflon tubing to the carbon monoxide monitor. A different portion goes through another sample line filter and Teflon tubing to the ozone monitor, and the remainder of the air sample is drawn out of the manifold by the vacuum pump. Heavy particulate matter collects in a trap at the bottom of the glass manifold. Meteorological data (i.e., wind speed, wind direction, and temperature) are collected at or close to the top of a tower. Those data and data from the monitors are sent to a data logger and then retrieved via a modem.

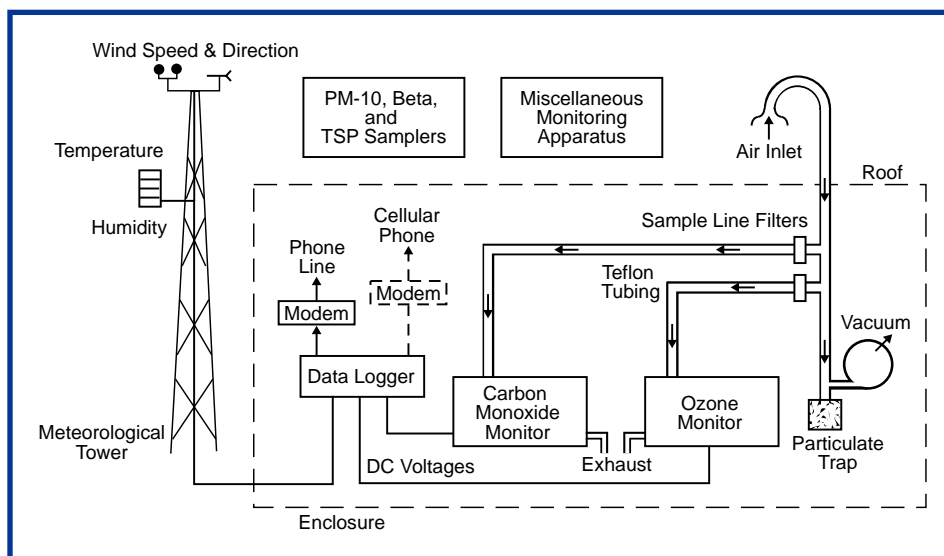

**Figure 4. Block diagram of an ambient air monitoring station**

CAMS in the Paso del Norte region are operated by four separate government agencies, serving three states in two countries. Even though there are slight variations in the layout of the CAMS operated by each agency, the basic layout at each station is the layout in Figure 4.

### MAINTAINING AIR QUALITY MONITORS

You will likely focus most of your scheduled equipment maintenance on cleaning and calibrating your monitoring analyzers to meet your project's QA/QC protocols. The required effort and frequency for this maintenance depends on the conditions at your monitoring locations. In addition to cleaning and calibrating your analyzers, you might need to perform maintenance that depends on factors specific to your project, your community, and your monitoring locations.

To ensure accuracy and precision of data derived from your air monitoring instruments, you need to develop reliable instrument calibration procedures. The EPA document *Ozone Monitoring, Mapping, and Public Outreach: Delivering Real-Time Ozone Information to Your Community* (EPA/625/R-99/007) provides two alternative calibration methods: primary calibration procedures and calibration using a transfer standard. You can find the document online at <http://www.epa.gov/airnow/cdmanual.pdf>.

You also should develop a preventive maintenance plan to ensure that the equipment monitoring and maintenance procedures are followed consistently. Your preventive maintenance plan should include:

- A short description of each maintenance procedure.
- The schedule and frequency for each procedure.
- A supply list of critical parts on hand.
- A list of maintenance contracts for instruments.
- Documentation showing that maintenance has been performed as required by maintenance contracts, the QA/QC plan, or the test plan.

Each component of your monitoring equipment has its own maintenance routine. In many cases, the equipment manual provided by the manufacturer offers detailed maintenance procedures. The table below describes the essential equipment maintenance activities.

Maintenance Item	Acceptance Limits	Measurement and Frequency	Corrective Action, if Needed
Shelter temperature	Mean temperature between 220° and 280° C (72° and 82° F), with daily fluctuation $\pm 2^\circ$ C ( $4^\circ$ F).	Check thermograph chart daily for excessive fluctuations.	Mark chart for the affected period. Repair or adjust temperature control system.
Sample introduction system	No moisture, foreign material, leaks, or obstructions; sample line connected to manifold.	Make weekly visual inspections.	Clean, repair, or replace as needed.
Recorder	Adequate ink supply and chart paper. Legible ink traces. Correct settings of chart speed and range switches. Correct time.	Make weekly visual inspections.	Replenish ink and chart paper supply. Adjust recorder time to agree with the clock; note on chart.
Data logger	Complete data logger storage or hard copy.	Make weekly visual inspections.	Perform maintenance according to manufacturer's specifications.
Analyzer operational settings	Flow and regulator indicators at proper settings. Analyzer set in sample mode. Zero and span controls locked.	Make weekly visual inspection.	Adjust or repair as needed.
Analyzer operational check	Zero and span within tolerance limits as specified.	Check every 2 weeks.	Isolate source of error and repair. After corrective action, recalibrate analyzer.
Precision check	Assess precision by repeated measurements.		Calculate and report results of precision check.

Checks performed as part of maintenance activities and the recommended frequency for each check are listed below.



Type of Check	
Sample flow check	Every 24 hours, or on each day when an operator is in attendance
Span check	Every 168 hours of instrument operation
Recorder span check	Every 168 hours of instrument operation
Zero check	Every 168 hours of instrument operation
Control frequency check	Every 168 hours of instrument operation
Sample frequency check	Every 168 hours of instrument operation
Temperature check	Every 720 hours of instrument operation
Pressure check	Every 720 hours of instrument operation
System leak check	Every 168 hours of instrument operation
Solenoid valve leak check	Every 720 hours of instrument operation

For the Paso del Norte Project, calibration occurs every 28 days during CO season. Span checks are performed once a week.

## 3.2 TRAFFIC MONITORING: AN OVERVIEW

Information obtained through monitoring of traffic is used to inform the public about traffic delays, road construction delays, accidents, and other impedances. Traffic monitoring includes using traffic sensors to collect traffic volume and speed information and video cameras to visualize delays caused by traffic. Other sources of traffic-related information include county engineering or transportation departments (e.g., for schedules of road construction) and police and fire departments.

Traffic monitoring information is used to:

- Determine current traffic volumes and show any trends or changes.
- Identify current and potential traffic congestion areas.
- Identify alternative routes.
- Alert the public about traffic impedances.
- Educate the public about the relationship between traffic and air pollution.
- Encourage the use of other modes of transportation (e.g., buses).
- Design transit improvement projects.

Additional information on traffic monitoring is available from the Federal Highway Administration (FHWA) at <http://www.fhwa.dot.gov/>. The U.S. Department of Transportation's Travel Model Improvement Program also provides information on traffic monitoring, including research on transit modeling and data collection (<http://tmip.tamu.edu/>).

### 3.2.1 DESIGN FACTORS FOR TRAFFIC MONITORING

To design your traffic monitoring program, you must first identify the purpose(s) of the monitoring. In addition to linking traffic data and air quality data, your purpose (s) may be to:

- Enhance public safety.
- Reduce congestion and travel delays.

- Improve access to traffic information.
- Increase awareness of alternative transit modes.
- Generate cost savings to travelers, transit operators, toll and border crossing authorities, and government agencies.
- Reduce negative environmental impacts.

Consider the following questions in designing your traffic monitoring project:

- What area do you want to include in the program?
- Are there already traffic monitors or cameras in place?
- Where are the traffic congestion areas in your region?
- What traffic parameters should you monitor?
- How often should you monitor traffic?

For the Paso del Norte Project, the main purpose of collecting traffic information is to inform the public about daily traffic conditions. The public can use the information to make decisions about what routes to take and when to travel. Another purpose of collecting traffic information is to provide information needed to estimate vehicle emissions in the region. Traffic data are input into transportation models to generate an estimate of the emissions from vehicle exhausts. This estimate is then used along with other information to educate the public about air pollution in the region and what they can do to improve air quality (e.g., reduce the number of vehicle trips on days when the temperature is high). Less time on the road results in reduced emissions from vehicle exhausts.

#### **WHAT AREA DO YOU WANT TO INCLUDE IN THE PROGRAM?**

As with air quality monitoring, the area in which you wish to conduct traffic monitoring may depend on the jurisdiction of your organization. You may decide to focus on areas with the highest traffic volume (e.g., metropolitan areas).

In the Paso del Norte region, sensors and cameras are used on arterials in the city of El Paso and on certain highways in the region to collect traffic data. Data also are collected at international bridge crossings using cameras. Traffic monitoring in the region was initiated before the start of the Paso del Norte Environmental Monitoring Project.

#### **ARE THERE ALREADY TRAFFIC MONITORS OR CAMERAS IN PLACE?**

State and local transit agencies and organizations conduct traffic monitoring. By working with these organizations, you can share data collected using existing traffic sensors and cameras and decide whether additional sensors and cameras are needed. When existing traffic sensors are used, they may have to be upgraded to provide near real-time traffic data.

In the El Paso metropolitan area, 600 intrusive traffic sensors (i.e., loop detectors using 12 or 14 AWG wire) collect speed and volume data. Traffic information is also collected through a Video Vehicle Detector System (VIVIDS) loop detector manufactured by Trafficon. A VIVIDS detector is a camera located on the mast arm of a traffic signal. VIVIDS detectors are used at several locations in El Paso (e.g., at the intersection of Montana and Airway Streets and along the Gateway East and West Boulevard). Forty cameras provide video images of traffic conditions in the Paso del Norte region. The Paso del Norte project team installed 16 cameras on the Mexico side of the international bridges.

## WHERE ARE THE TRAFFIC CONGESTION AREAS IN YOUR REGION?

Your traffic monitoring needs are based on the number of possible congestion areas in your region, usually major roads, bridges, and intersections. If your resources are limited, you should monitor those areas that have the greatest affect on traffic in your region.

In the Paso del Norte region, the El Paso City Department of Traffic and Transportation operates traffic loop counters on major arterials as part of the City's Transportation Improvement Program. The Texas Department of Transportation (TxDOT) collects traffic volume data on instrumented roadways for portions of I-10 and U.S. 54, sharing those data with the City through an ongoing contract with the El Paso Metropolitan Planning Organization. In addition, traffic information at international bridge crossings (including wait times) is provided by the U.S. Customs and Immigration Service on an hourly basis. These efforts address the number one need identified in the El Paso Intelligent Transportation System Early Development Plan: current and reliable traffic information. Near real-time traffic data are not available for Sunland Park, New Mexico, and Cd. Juárez, Chihuahua.

## WHAT TRAFFIC PARAMETERS SHOULD YOU MONITOR?

The following traffic parameters may be included in your monitoring program.

- Traffic volume—vehicle count.
- Vehicle presence—whether there is a vehicle in the detection zone of a sensor.
- Vehicle passage—vehicle movement through the detection zone of a sensor.
- Vehicle speed.
- Vehicle classification—by gross vehicle weight.
- Vehicle weight.
- Gap and headway—distance and time intervals between vehicles passing a specified location.
- Travel time.
- Vehicle and lane occupancy—the number of persons, including driver and passenger(s), in a vehicle and the number of vehicles in a lane.

The traffic parameters that you monitor are based on your project's objectives and on the funds available. Different types of traffic monitoring sensor have different applications. Depending on the number of monitors needed, your budget may dictate the type of monitors you can install.

Traffic parameters measured in the Paso del Norte region are listed below.

Traffic Monitoring Locations in the Paso del Norte Region	
Interstate-10	Traffic volume Vehicle speed
U.S. Route 54	Traffic volume Vehicle speed
Various locations in city of El Paso	Traffic volume Vehicle speed

## HOW OFTEN SHOULD YOU MONITOR TRAFFIC?

Gathering near real-time traffic data requires frequent monitoring—multiple samples per hour. The public uses traffic data to plan their activities and you need enough data to report current information, including delays. You can conduct several kinds of traffic monitoring projects, such as those:

- At fixed locations on a continuous basis.
- At fixed locations during rush-hour times.
- At selected locations on an as-needed basis or to answer specific questions.

Traffic volume and speed information and traffic video images communicated through the Paso del Norte Environmental Project are collected at 5-minute intervals at fixed locations in El Paso and at fixed locations on some of the highways in the area. Volume and speed measurements are summarized on an hourly basis, and data sets and displays are refreshed on the Internet every 60 minutes. Information on international bridge crossings and wait times collected by the U.S. Customs and Immigration Service is also refreshed on the Internet every 60 minutes.

### 3.2.2 SELECTING YOUR TRAFFIC MONITORING EQUIPMENT AND LOCATIONS

A traffic sensor, one type of traffic monitoring equipment, includes three components: 1) the transducer, 2) the signal processing device, and 3) the data processing device.

#### Traffic Monitoring Equipment—Sensors

**Transducer.** Detects the presence or passage of a vehicle or its axles.

**Signal processing device.** Converts the transducer output to an electrical signal.

**Data processing device.** Converts the electrical signal from the signal processing device to traffic data. This device includes computer hardware and firmware.

Reference: Federal Highway Administration 2000. A Summary of Vehicle Detection and Surveillance Technologies Used in Intelligent Transportation Systems. <http://www.fhwa.dot.gov/ohim/tvtw/vdstits.htm>

You can also monitor traffic using still cameras or video cameras to capture traffic volume, delays, and other obstructions. The video image system includes cameras, computers to digitize and send the image, and software to interpret the image.

#### EQUIPMENT SELECTION

Your selection of remote near real-time traffic monitoring equipment depends on your project's objectives. When selecting monitoring equipment, you should consider equipment life, reliability, and maintenance requirements.

To decide which traffic monitoring equipment to use in your near real-time environmental monitoring program, you can consult the Federal Highway Administration's *A Summary of Vehicle Detection and Surveillance Technologies Used in Intelligent Transportation Systems*, located on the FHWA's Web site at <http://www.fhwa.dot.gov/ohim/tvtw/vdstits.htm>. The summary includes principles of operation, applications and uses, advantages and disadvantages, and other relevant information for the following technologies:

- ***Intrusive technologies.*** Sensors installed directly on or under the pavement surface. These sensors provide reliable traffic information. One drawback to this type of sensor is traffic disruption caused for installing and repairing equipment. Intrusive sensors include:
  - Pneumatic road tubes. Monitoring parameters include traffic count (short-term) and vehicle classification.
  - Inductive loop detectors. Monitoring parameters include traffic count; vehicle presence, passage, speed (using a two-loop speed trap or one loop with algorithms), and classification; and lane occupancy.
  - Piezoelectric sensors. Monitoring parameters include traffic count, vehicle spacing, vehicle weight, and vehicle speed (using multiple sensors).
  - Magnetic sensors. Monitoring parameters include traffic count, vehicle presence (depending on model), vehicle speed, and lane occupancy.
  - Weigh-in-Motion (WIM) sensors. Monitoring parameters include vehicle weight, traffic count (volume), vehicle speed, and vehicle classification.
- ***Non-intrusive technologies.*** Sensors installed above ground (above traffic lanes or on the side of the road). These sensors provide traffic data with less traffic disruption than do intrusive technologies. Many of these sensors have multiple lane applications. Non-intrusive sensors include:
  - Video image processors. Monitoring parameters include traffic count; vehicle presence, occupancy, speed, and classification; and lane occupancy.
  - Microwave radars. Monitoring parameters include traffic count; vehicle presence, speed, and classification; and lane occupancy.
  - Passive infrared sensors. Monitoring parameters include traffic count; vehicle presence, passage, speed, and classification; and lane occupancy.
  - Active infrared sensors. Monitoring parameters include traffic count; vehicle presence, speed, and classification; and lane occupancy.
  - Ultrasonic sensors. Monitoring parameters include traffic count, vehicle presence, vehicle speed (two sensors) and lane occupancy.
  - Passive acoustic array sensors. Monitoring parameters include traffic count, vehicle presence, vehicle speed (with assumed car length), and lane occupancy.
  - Combinations of sensor technologies.

When selecting your traffic monitoring equipment, you need to consider outside factors that might affect the operation of the sensor or camera. Outside factors and the sensitivity of monitoring equipment to the factors are listed below.

Installation, operation, and maintenance procedures and requirements for traffic sensors might be a big factor in your choice of monitoring equipment for your project. See Section 3.2.3 for more details on installing, operating, and maintaining traffic monitoring equipment.

A camera used to monitor traffic can be equipped with an automatic zoom lens or a manual zoom lens. Cameras also have varying magnification capabilities. Depending on the location and view to cover, you should choose the camera that best fits your location.

Outside Factors Affecting Traffic Monitors	Monitoring Equipment Less Sensitive to Factors	Monitoring Equipment More Sensitive to Factors
Temperature (high or low and rapid changes)	Quartz sensors (WIM)	Pneumatic road tube Inductive loop detector Piezoelectric sensor Ultrasonic sensor Passive acoustic array sensor
Heavy usage (wear and tear)	Magnetic sensor	Pneumatic road tube Inductive loop detector Ultrasonic sensor
Vehicle speed variation		Piezoelectric sensor
High vehicle speed	Piezoelectric sensor	
Low vehicle speed		Passive acoustic array sensor
Inclement weather	Microwave radar Passive acoustic array sensor (precipitation)	Video image processor Infrared sensor
Headlights/sunlight		Video image processor Infrared sensor
Air turbulence		Ultrasonic sensor

Reference: Federal Highway Administration 2000. A Summary of Vehicle Detection and Surveillance Technologies Used in Intelligent Transportation Systems. <http://www.fhwa.dot.gov/ohim/tutw/vdstiis.htm>.

Traffic monitoring equipment used in the El Paso area includes 600 intrusive traffic sensors and 40 video image cameras (an additional 32 cameras are expected to be installed by the end of 2003). Sensors collect volume and speed data on the El Paso arterials and on Interstate 10 and U.S. 54. Video images show delays on highways and at international bridges. Every camera has a manual zoom lens with a magnification factor of 4, and is manufactured by COHU.

Data from the traffic sensors on Interstate 10 and U.S. 54 are logged into an automated traffic management system operated by the TxDOT in Austin. Traffic data collected in the city of El Paso are logged into a system called QuickNET (from Bytrans) by the City. These data are then processed for communication to the public.

### MONITORING LOCATIONS

You should select monitoring locations that best fulfill the objectives of your remote near real-time traffic monitoring project. Consider the monitoring location checklist in Section 3.1.2 when choosing your monitoring locations.

### 3.2.3 INSTALLING, OPERATING, AND MAINTAINING TRAFFIC MONITORING EQUIPMENT

Planning and coordination are necessary for installing any type of traffic monitoring equipment—sensors or cameras. The installation and maintenance of the equipment may result in traffic disruption including lane closures. You need to set a schedule and inform the public before beginning work.

#### INSTALLING TRAFFIC MONITORING EQUIPMENT

As indicated in the section above, traffic sensors fall into two major categories—intrusive technologies and non-intrusive technologies. Intrusive sensor installation results in more traffic disruption than does installation of non-intrusive sensors. Consult the equipment manufacturer's manual for detailed instructions on how to install the traffic monitoring equipment.



When installing video cameras for traffic monitoring, you need to consider various factors. You need to ensure that the camera is not blocked by large vehicles or other obstructions, and you need to consider elevation changes, road curves, and overpass and underpass structures in your line of sight. The camera should be mounted to maximize stability and image quality in all conditions (e.g., when winds are strong or traffic causes vibrations).

As mentioned previously, existing traffic monitoring equipment is used to collect the traffic volume data communicated to the public through the Paso del Norte Environmental Monitoring Project. The City of El Paso's Traffic and Transportation Department operates loop counters and road traffic cameras on city arterials, and the Instituto Municipal de Investigación y Planeación operates border crossing cameras at the international bridges in the Paso del Norte region. In addition, the Texas Department of Transportation operates loop counters at locations on I-10 and U.S. 54.

### OPERATING TRAFFIC MONITORING EQUIPMENT

Automated traffic monitoring equipment collects traffic data and automatically sends the information to your database. With non-automated equipment, you must call the monitoring equipment to download the data. The box below briefly explains how the technologies listed in Section 3.2.2 work (reference: Federal Highway Administration's *A Summary of Vehicle Detection and Surveillance Technologies Used in Intelligent Transportation Systems*, fall 2000).

#### Operation of Traffic Monitoring Equipment—Brief Overview

**Pneumatic road tube.** A portable unit that senses vehicle as their tires pass over the tube. The tire causes a pulse of air pressure to close an air switch. This switch produces an electrical signal that is then sent to the counter.

**Inductive loop detector.** The inductive loop of the sensor (signals with frequencies between 10 and 50 KHz) decreases when a vehicle stops or passes over the loop. The oscillation frequency increases, causing the electronic unit to send a signal to the controller.

**Piezoelectric sensor.** The sensors create a voltage signal proportional to the force or weight of the vehicle.

**Magnetic sensor.** Detects the presence of a metallic vehicle based on perturbation of Earth's magnetic field.

#### **WIM sensors.**

- **Bending plate**—a unit consisting of plates with strain gauges. The strain value is used to estimate static weight based on various calibration parameters (e.g., vehicle speed).
- **Piezoelectric**—see “piezoelectric sensors” above.
- **Load cell**—weight scales that use a pressure transducer to transmit weight information to data collection equipment.
- **Capacitance mat**—a unit consisting of steel sheets and dielectric material. The mat senses vehicles when the space between the steel sheets decreases (and the capacitance increases).

**Video image processor.** A system including cameras, a microprocessor-based computer, and image software. Vehicles are detected by changes between successive frames.

**Microwave radar.** Detects vehicle presence when transmitted radar energy is reflected back to the antenna. A receiver can then calculate various traffic monitoring parameters.

**Passive infrared sensor.** Detects energy (graybody emission due to non-zero surface temperature) emitted from vehicles, roads, etc.

**Active infrared sensor.** Detects vehicle presence when transmitted infrared energy is reflected back.

**Ultrasonic sensor.** Detects vehicle presence when transmitted pressure waves of sound energy are reflected back.

**Passive acoustic array sensor.** Detects approaching vehicles using audible sounds. The unit includes an upper and lower microphone.

After you install your traffic monitoring equipment, you should develop written SOPs that describe the operation of each part of the monitoring equipment. *Guidance for the Preparation of Standard Operating Procedures for Quality-Related Documents* (EPA/600/R-96/027) provides information about developing, documenting, and improving SOPs. You can find it by searching the EPA Web sites for documents by publication number (<http://www.epa.gov/clariton/clhtml/pubtitle.html>).

You should also conduct QA/QC checks on your monitoring equipment to ensure that it functions properly.

## **MAINTAINING TRAFFIC MONITORING EQUIPMENT**

You will likely focus most of your scheduled equipment maintenance on calibrating your traffic monitoring sensors to meet your project's QA/QC protocols. The required effort and frequency of maintenance depends on the types of sensors you use and the conditions at your monitoring locations. In addition to sensor calibration, you might need to perform scheduled maintenance. Maintenance requirements depend on factors specific to your project and your monitoring locations.

You also should develop a preventive maintenance plan to ensure that the sensor and camera operations and maintenance procedures are followed consistently. Your preventive maintenance plan should include:

- A short description of each maintenance procedure.
- The schedule and frequency for each procedure.
- A list of critical parts on hand.
- A list of maintenance contracts for instruments.
- Documentation that shows maintenance is performed as required by maintenance contracts, the QA/QC plan, or the test plan.

Each component of your traffic monitoring equipment has its own maintenance routine. In many cases, the equipment manual provided by the manufacturer offers detailed maintenance procedures.

Cameras and multiplexers (modems) used in the Paso del Norte region are maintained once per week. The zoom and focus of the cameras, the condition of the wiring, and all connections are checked, and the equipment is cleaned.

## **3.3 COLLECTING WEATHER INFORMATION**

Weather information is important to the public. They want to know the current weather conditions as well as the weather forecast. This information also is important with respect to the air quality of an area. For example, the current temperature is an indicator of the potential for high ground-level ozone levels, particularly during the summer. The weather forecast also can be used to help predict future air quality conditions in an area.

### **3.3.1 WEATHER PARAMETERS**

You may want to collect information for some of the weather parameters described below through your environmental monitoring program.

- *Ambient air temperature.* The hotness or coldness in the atmosphere.

- *Dew point (or dew point temperature)*. A measure of atmospheric moisture. It is the temperature to which air must be cooled to reach saturation (assuming air pressure and moisture content are constant).
- *Depth of inversion layer*. The depth of a layer of air where temperature rises with height.
- *Mixing height*. The height below which relatively vigorous mixing (or vertical mixing) occurs in the atmosphere.
- *Precipitation*. Any form of water, such as rain, snow, sleet, or hail, that falls to the earth's surface or the amount of rainfall (or other precipitation) that has fallen in a specific area within a specific time period.
- *Pressure*. Atmospheric pressure is caused by the weight of the atmosphere. At sea level, pressure has a mean value of one atmosphere; pressure decreases with increasing altitude.
- *Relative humidity*—A measure of the water vapor content of the air, usually as a percentage.
- *Solar radiation*. Radiation from the sun.
- *UV forecast*. Recommends whether the level of ultraviolet (UV) radiation reaching the atmosphere can cause overexposure to various groups of people.
- *Visibility*. The farthest distance that atmospheric conditions allow one to see without instruments.
- *Wind speed and direction*. Usually miles per hour that wind is traveling and the source direction.

### 3.3.2 SOURCES OF INFORMATION

The Web site for the U.S. National Weather Service (<http://www.nws.noaa.gov/>) displays basic weather information collected through the Automated Surface Observation System. These data include temperature, wind speed, wind direction, UV radiation intensity, dew point, and precipitation. The National Weather Service (NWS) updates its weather data hourly, except for precipitation data, which it updates every 6 hours. This information is available to the public through a file server at the NWS gateway using file transfer protocol (FTP).

Another source of information on UV radiation is EPA's SunWise School Program (<http://www.epa.gov/sunwise/uvindexcontour.html>).

Temperature, wind speed, and wind direction data can also be collected at air quality monitoring stations. The frequency of collection for weather data should be the same as the frequency of collection for air quality data.

For the Paso del Norte Project, wind speed, wind direction, and temperature data are collected at the CAMS in the region. These data are then transferred and processed with air quality data.

As part of the Paso del Norte Project, weather data from the NWS in Santa Teresa, New Mexico, are retrieved by a server at the University of Texas at El Paso by means of a FTP connection. These data are processed through a series of algorithms and redisplayed. Current temperature, UV intensity, relative humidity, wind speed, and heat index readings appear in digital form on the Paso del Norte Environmental Monitoring Project Web site. Graphs showing changes in various weather parameters also are on the Web site. The UV radiation information on the Project's Web site comes from EPA's SunWise School Program.

## 3.4 LESSONS LEARNED FROM THE PASO DEL NORTE ENVIRONMENTAL MONITORING PROJECT

### BI-NATIONAL ORGANIZATIONAL SUPPORT: KEY TO SUCCESS

The key to the success of the Paso del Norte Environmental Monitoring Project is the endorsement and support of an international organization overseeing air quality in the region. The Paso del Norte Joint Advisory Committee (JAC) was established through an annex of the bi-national La Paz Agreement to oversee activities within the regional air basin. The JAC includes representatives from federal, state, and local governments; utilities; industry; and educational institutions from both the United States and Mexico. As a result, JAC approval represents full bi-national cooperation and support from its member organizations.

Equally important, the JAC provides a forum to assign responsibilities and authority for collecting and processing information. It also is a non-partisan organization through which all members can take credit for regional accomplishments such as the Paso del Norte Environmental Monitoring Project.

The JAC developed a strategic plan that includes a work plan to improve air quality in the Paso del Norte region. Many of the tasks in the Paso del Norte Environmental Monitoring Project came directly from the strategic plan. As a result, the Paso del Norte Project is an integral part of a comprehensive plan developed by a sanctioned bi-national organization. This helps ensure the success of the current project as well as support to continue the project beyond the limits of the EMPACT grant. This type of support is very important for projects that involve multiple jurisdictions.

### GEOGRAPHIC INFORMATION SYSTEMS

After many years of research, vehicles were identified as the most significant source of air pollution in the Paso del Norte region. To assess the impact of vehicles on air pollution, the Project collects near real-time information on traffic conditions in the region and at the international ports of entry. That information, along with near real-time ambient air quality and meteorological data, is input into various transportation models to develop vehicle emission estimates. Outputs from the transportation models are then input into the photochemical modeling being conducted for the region by EPA Region 6 and the Texas Commission on Environmental Quality. A system is needed to integrate all of the near real-time information that is collected. Geographic information systems (GIS) serve this role in the Paso del Norte Project.

GIS combine geographic features (described as lines, points, and polygons) with information stored in tabular or database format. In the Paso Del Norte Project, CAMS are input as points and contain associated air quality and meteorology information. Roadway segments are input as lines or polylines, and contain traffic volumes, speeds, and limited vehicle mix characteristics. Land use is summarized by polygons and equated to general area emissions.

Two GIS programs are used in the Paso del Norte Project: ArcView by Environmental Science Research Institute and TransCAD by Caliper Corporation. ArcView is used to store core data along with spatial analysis and to visualize multiple layers or themes such as roads, terrain, and monitor locations. TransCAD is used for transportation modeling and to develop emissions estimates. Both of these programs support industry-standard file formats, which allows data to be shared and exchanged. The role played by these two GIS programs is critical to the success of the Paso del Norte Project.

### **TRANSPORTATION MODELING IN A BI-NATIONAL REGION**

An important component of the program to inform the public about air quality in the Paso del Norte region is the transportation model used to develop vehicle emission estimates for the region. The input variables for the Paso del Norte transportation model (i.e., the TransCAD model developed by Caliper Corporation) differ dramatically between El Paso and Cd. Juárez. For example, peak travel times are different for the two cities and also are unique for border crossings. In addition, inspection times at bridges differ which affects both the number of crossings and the routes taken by those who commute daily between the two cities. Emission factors for vehicles housed in El Paso and Cd. Juárez are also different: vehicles housed in Cd. Juárez are on average 7 years older than the vehicles housed in El Paso, and are not subject to the same inspection and maintenance programs as are vehicles housed in El Paso. These differences in the input variables illustrate how transportation modeling can be complicated in a bi-national region such as Paso del Norte. To ensure that the results of the transportation modeling are accurate, all jurisdictions in an area must support the modeling efforts by providing accurate inputs for the model.

### **MULTIPLE USES OF NEAR REAL-TIME DATA**

The Paso del Norte Project's near real-time traffic data can be used for purposes other than public communication. For example, emergency personnel can use traffic volume information and current images of traffic conditions to respond to accidents. In addition, near real-time border crossing information and associated wait times are important to federal agencies responsible for overseeing the international ports of entry in the region. Because of the Paso del Norte Project, the infrastructure needed to communicate those data is in place. The multiple uses of the data demonstrate the importance of a comprehensive approach to data collection and management in a large, bi-national metropolitan area.

# 4 PROCESSING TIMELY ENVIRONMENTAL INFORMATION

---

**A**fter you collect your timely environmental information, you must process it and communicate it to the public. This chapter discusses how to transfer data from automatic monitoring equipment to a central location and how to manage the data so they can be communicated to the public. (Chapter 5 addresses the related issue of how best to present data to the public using data visualization tools.)

Using the Paso del Norte Environmental Monitoring Project as a model, this chapter provides you and your community with suggestions on how to process timely environmental information. Section 4.1 contains an overview of processing environmental information. Sections 4.2 and 4.3 contain information on transferring data and managing data, respectively.

## 4.1 PROCESSING ENVIRONMENTAL INFORMATION: AN OVERVIEW

To process near real-time environmental data, you need to develop a data transfer and management system. This system can benefit your community by enabling you to control data collected using automatic monitoring equipment. By using the system's software, you can program your system to collect data from remote sampling locations at specified intervals and store them. With little or no need for human intervention, the information can be exported to a database, set in a standard format, and merged with manually collected data. Once the data are available in a database, they can be used in a wide variety of applications. They can be:

- Manually inspected for quality control purposes.
- Plotted using graphing software.
- Mapped using a geographic information system (GIS).
- Processed and combined with other data.
- Made available to the public via a Web server.

Timely processing of environmental data is key to creating a useful tool that can affect daily activities of the public. There are two major steps to processing the data: 1) transferring the data from data loggers at remote monitoring locations to your central hub; and 2) managing the data in preparation for dissemination to the public.

## 4.2 TRANSFERRING ENVIRONMENTAL DATA TO YOUR CENTRAL HUB

Data can be transferred from one location to another either automatically or manually. Automated data transfer systems are easier to operate than are manual systems. Automated systems, after collecting data using a data logger, send the data automatically to your computer and data acquisition system. The data are typically put into a comma-delimited ASCII file (a standard format). From this file, data can be converted to HTML tables. Non-automated data transfer systems require an additional step—the monitoring station has to be called manually to download the data.



## Processing Data—Definition of Terms

**ASCII.** **A**merican **S**tandard **C**ode for **I**nformation **I**nterchange is a built-in binary code for text and communications. ASCII text files can be used between applications that do not import each other's format.

**Daemon.** A UNIX program that executes (usually at startup) and remains ready to operate when needed. This program can automatically start another process at a designated time.

**FTP.** **F**ile **T**ransfer **P**rotocol transfers files over a TCP/IP (see below) network (e.g., the Internet). The protocol includes functions to log onto the network, list directories, and copy files.

**HTML.** **H**yper **T**ext **M**arkup **L**anguage is the document format used on the Internet. World Wide Web pages are built using HTML codes embedded in the text.

**Intranet.** An in-house LAN (**L**ocal **A**rea **N**etwork) or client/server system not accessible by the general public. The communications protocol and hypertext links operate the same as on the Internet.

**TCP/IP.** **T**ransmission **C**ontrol **P**rotocol/**I**nternet **P**rotocol is the Internet protocol that allows communications between dissimilar systems. The TCP part provides transport protocol functions to ensure that all the information sent is received correctly. The IP part provides the routing mechanism.

Reference: Alan Freedman and Alfred and Emily Glossbrenner. 1998. *The Internet Glossary and Quick Reference Guide*. New York: American Management Association.

### 4.2.1 DATA TRANSFER COMPONENTS

To receive data collected automatically, you can use a modem (or other) connection from each monitoring station to your central hub computer. This allows data logging from more than one monitor to occur on a single computer. You typically need data acquisition and processing software and a data storage module to collect and manage the data. Once data are delivered to the central hub computer, they are filtered and stored in a file in the data acquisition system where further processing and reporting occurs.

In addition to transferring the data from remote monitoring locations to your central hub computer, you also may collect data from other sources. These data might or might not need to be processed further for public use. For example, weather data can be collected from the National Weather Service. These data, which already have been processed; you can place them on your Web site after formatting them, and they can then be accessed via an Internet connection.

#### Environmental Data Transfer Components

**Central hub computer(s).** One or more computers can be used to retrieve the data from various sources (e.g., remote monitoring locations and other Web sites).

**Computer connection (e.g., modem connection).** This connects the computer at the remote monitoring locations to the central hub computer. It also can connect your central hub computer to other computers on your network or to data on Web sites. Data may be transferred via modem, intranet FTP, or microwave link.

**Data acquisition software.** You can purchase software (or develop your own computer routine) to automatically collect the data from remote locations in a standard format (e.g., ASCII text).

**Validation software and other processing software.** You can purchase software (or develop your own computer routine) to perform quality control analysis on the collected data. Once the data are validated (i.e., pass quality control criteria), you can further process the data for public use.

**Database/archive storage system.** This system stores all your data by date and time of collection. The system will be most useful if you can use it to perform queries of the data.

Another example of data from other sources is the ozone data (from 1,300 monitoring stations) that EPA retrieves, manages, and distributes through its Data Management Center (DMC). The EPA document *Ozone Monitoring, Mapping, and Public Outreach: Delivering Real-Time Ozone Information to Your Community* (EPA/625/R-99/007) provides details on the DMC computer system and the equipment needed to connect to the system. You can find the document online at <http://www.epa.gov/airnow/cdmanual.pdf>.

When collecting data from various sources, you may designate certain project partners to transfer and validate certain types of information. Assignments may be based on geographical or jurisdiction factors, experience factors, or resources available by each entity. The Paso del Norte Project Team used various agencies to transfer data to one central hub computer.

#### **4.2.2 PASO DEL NORTE PROJECT—DATA TRANSFER COMPONENTS**

In the Paso del Norte Environmental Monitoring Project, air quality data, traffic volume data, traffic video images, weather data, and static and live images from Webcams, hubs, and Web sites are transferred to a central hub location. Components of the data transfer system are:

- *Air quality data and meteorological data collected at continuous air monitoring stations (CAMS).*

For CAMS in El Paso operated by the Texas Commission on Environmental Quality (TCEQ):

- Data transferred from CAMS to TCEQ for validation using the IPS Meteostar system.
- Validated data transferred from TCEQ to the University of Texas at El Paso (UTEP) via secure intranet FTP.

For CAMS in El Paso operated by the El Paso City-County Health and Environment District:

- Data transferred from CAMS to TCEQ via modem for validation using the IPS Meteostar system.
- Validated data transferred from TCEQ to UTEP via secure intranet FTP.

For CAMS in Cd. Juárez, Mexico:

- Data transferred from CAMS to Universidad Autonoma de Cd. Juárez (UACJ) via dial-up connection.
- Data transferred from UACJ to UTEP via Internet2 for validation.

(Note: CAMS in Cd. Juárez are scheduled to be incorporated into the IPS Meteostar system. Radios will be used to transmit data from Cd. Juárez to TCEQ.)

For CAMS in Sunland Park, New Mexico:

- Data transferred from CAMS to UTEP via dial-up connection for validation.

## Accessing Your Data

You might want to use a dedicated hard-wired Internet connection to access data from your monitoring stations. This type of connection costs more than dial-up and modem connections. Dial-up and modem connections are less reliable: you may be unable to connect to the monitoring station when the telephone line is busy or the modem does not work. They are also much less efficient. For example, suppose you have 1 hour to collect data from 40 monitoring stations for a 1:00 p.m. poll. Using the dial-up method, it takes you approximately 1 minute to connect to each monitor— 40 minutes total. You then have only 20 minutes left to process all of the data files, which is not enough time to meet your deadline.

- *Traffic volume data.*

You can transfer traffic volume data and video camera images from your monitoring stations to your central hub using fiber optic lines, phone line connections, or wireless connections. Components of the traffic volume data transfer system for the Paso del Norte Environmental Monitoring Project include:

- Traffic volume data from loop counters in El Paso and on I-10 and U.S. 54 transferred to the El Paso Traffic and Transportation (T&T) Department via fiber optic lines.
- Data from El Paso T&T transferred to UTEP via dial-up modem.

Traffic volume data are automatically placed on the Paso del Norte Environmental Monitoring Project's Internet server using a Unix CRON (clock daemon). Traffic volume data and border wait times are stored on a secure intranet site integrated with an industry-standard relational database (using a ColdFusion application server, manufactured by Macromedia) and Internet GIS applications (ArcView Internet, manufactured by ESRI) to allow police, fire service, and EMS to register current incidents.

- *Traffic video images.*

Traffic video images are transferred in the Paso del Norte Environmental Monitoring Project using the following components:

- El Paso traffic images transferred to El Paso Metropolitan Planning Organization (MPO) via a fiber optic system.
- Traffic images from MPO transferred to UTEP via secure intranet FTP.
- Traffic images for international bridges transferred to the Instituto Municipal de Investigación y Planeación (IMIP) via multiplexer wire modem and then to the City of El Paso via a microwave connection. The images are then transmitted to UTEP via a dedicated T1 line.

- *Bridge crossing and wait times.*

Data from U.S. Customs and Immigration Service transferred to UTEP via Internet.

- *Weather data.*

Weather data are collected from the CAMS and from the NWS. Transfer components for the weather data collection system are:

- Weather from NWS transferred to UTEP via Internet.
- Weather information from CAMS transferred to UTEP (see above air quality data transfer components).
- NWS satellite links (visibility images) transferred to UTEP via Internet.
- UV index forecast from EPA’s SunWise School Program Web site transferred to UTEP via Internet.

### FREQUENCY OF DATA TRANSFER

To maintain near real-time data on a Web site, data must be updated on a continuous basis. Air quality data are collected at the CAMS in the Paso del Norte region every 5 minutes. Each afternoon around 3:00 p.m., the 5-minute data sets for the past 24 hours are submitted to UTEP, where they are processed and communicated to the public.

Traffic volume data are summarized by MPO every hour. These data are then sent to UTEP via a secure intranet FTP, where the data sets and displays on the Web site are refreshed every 60 minutes. Border crossing information and bridge wait times also are updated every hour.

The Paso del Norte project team updates the traffic video images on the Web site every 15 minutes using an automated modem system. The site also offers visibility images from UTEP Southern View, Ranger Peak, and downtown (looking west from Chelsea Retirement Center); these are live images, updated every 10 minutes with the system used to update traffic video images.

Data from the NWS Web site are updated hourly for all parameters except precipitation. NWS updates precipitation data every 6 hours. UTEP refreshes the data on the Web site every hour.

## 4.3 MANAGING ENVIRONMENTAL DATA

Once you have collected your data from monitoring stations, hubs, and Web sites, you need to format and process the data using standard formats and computer routines, then store the data in a database. You also may perform quality assurance/quality control checks at this point. Data stored in the databases can be used to update your Web site automatically, and in models (e.g., emission models or transit models).

### System Components—Managing Data

**Computer(s).** You might use one or more computers to format the retrieved environmental monitoring data. You need to ensure that your computer has the appropriate features and software necessary to format and manage the data.

**Computer routines.** Software that formats, performs quality control analyses on, modifies, or converts the collected data for dissemination to the public.

**Database/archive storage system.** This system stores all your data by date and time of collection. You should be able to perform queries of the data. These queries can help you to develop transit models and other environmental data tools.

**Models.** Computer models analyze your raw data for various purposes. For example, you can use a model to extrapolate the data (e.g., if you have transit data for a major road, you can use set parameters to determine traffic volume on connecting roads) and analyze different scenarios (e.g., the effect that a lane closure would have on border wait times).

### 4.3.1 FORMATTING AND PROCESSING DATA

Environmental data need to be in a standard format. This is particularly true if the data have come from several sources. To achieve standard formats, you may need to create computer routines to multiply or divide the data by the appropriate factors.

At this point, the data may undergo quality control. Any data not passing the selected quality control criteria should be flagged and not used. You will still want to store such data in your databases; you may notice trends when data are out of specification—trends you can use when you perform corrective action.

For the Paso del Norte Project, relational database technology is integrated with dynamic Web pages. Graphics on Web pages that change with the change in conditions (e.g., the Air Quality Index) are built using Adobe Image Ready. The resulting code is then modified to a ColdFusion Markup (\*.cfm) language, and the variables are linked to a database. As the database is updated, the Web page loads new images and text based on its contents. As a result, there is flexibility in designing pages. Original data can be validated and imported into the database through standard scripts, or interactive forms can be designed to allow partner institutions to update the information through a secure intranet site.

The Paso del Norte project team transfers the environmental data as comma-delimited ASCII text. The Team uses the following standard units for the air quality pollutants:

- Ozone: parts per billion (ppb).
- Carbon monoxide: parts per million (ppm).
- PM<sub>2.5</sub>: micrograms per cubic meter ( $\mu\text{g}/\text{m}^3$ ).
- PM<sub>10</sub>: micrograms per cubic meter ( $\mu\text{g}/\text{m}^3$ ).
- Sulfur dioxide: parts per billion (ppb).

Air quality data from the Cd. Juárez CAMS is received in a proprietary report format (EDAS Version 3.0). The ASCII report is processed via a script to output a fixed-format data file.

Air quality data from the New Mexico CAMS also is received in a proprietary report format (i.e., PC208W). Java scripts are used to extract the data from the report format and output the fixed-format data file.

The format for the air quality data includes AIRID, year, month, day, hour, minute, type, value, and averaging time. Java scripts are used to validate the data and reprocess them into the directory structure used by the visualization software. Custom visualization applications are written in C run within Iris Explorer, a commercial mathematical modeling application, to generate time sequence TIFF images. Adobe Premier is used to sequence the images into animated movies, GIFs, and other digital formats.

Traffic data are retrieved every 10 minutes and processed to extract average speeds, traffic counts, and truck counts. The resulting data are imported into a relational database and linked to the road network using the Environmental Systems Research Institute's ArcIMS GIS to allow visualization of near real-time speeds and traffic volumes. Transportation data are also imported into Caliper's TransCad transportation model, which is used to develop improved routing and emergency response applications and near real-time vehicle emissions estimates.

Images from the TransVista Intelligent Transportation System are collected via a video card from a computer connected directly to the fiber optic system at the City of El Paso municipal building. Once every 10 minutes, four consecutive frames are captured and merged into an animated GIS image and sent via a dedicated T1 line to UTEP for hosting on the Web site.

Border crossing wait times are based on the length of the vehicle wait lines at the international bridges. They are entered manually into a relational database by staff at Radio 1490, a Spanish radio talk station, through a secure intranet site. Wait times are validated manually once a week by students who cross into El Paso to attend classes at UTEP.

Images of border crossings are collected using a remote security camera system. They are then transmitted via telephone lines to a central computer at IMIP. A microwave communication system is used to transmit the images from IMIP to the El Paso Municipal building. The images are then transmitted to UTEP via a dedicated T1 line. Information from IMIP can also be sent to UACJ, where there is a backup system for transmitting data across the Mexico/U.S. border. Border crossing images are updated every 30 seconds. Telephones used to transmit border crossing images to IMIP are scheduled to be replaced with a radio communication system to reduce cost and to reduce the potential for vandalism.

Weather data and the UV index are downloaded to a central hub computer as ASCII text. Temperature, wind speed, wind direction, and the UV index are placed directly into a relational database and retrieved via the Web site using ColdFusion by Macromedia.

#### **4.3.2 STORING DATA**

After you transfer and format the data, you can store them in databases with a name that reflects the time and date when they were obtained and identifies their source. When practical, images have times and dates embedded. Because time for transferring and validating data varies, the time on stored files typically does not reflect the exact collection time. However, the original images and raw data should contain this critical information. From the databases, stored data can be converted or modified for use on your Web site (e.g., converted to HTML tables), with other community outreach materials, or in models (e.g., emissions and transit models). You also can query the data for analysis and case studies.

For the Paso del Norte Project, images and raw data are archived and backed up on a daily basis. ASCII data are imported into a relational database as needed to support the various applications and Web pages. Queries can be performed in the database to identify data sets of interest and download them using anonymous FTP file transfer. Archived data are compressed using gzip (\*.gz) to insure compatibility across operating systems. Raw data, images, and databases are transferred to a CD for permanent storage once per month. TransVista images of freeway conditions are not stored because of restrictions on the use of the images.

#### **4.3.3 USING DATA IN MODELS**

Computer modeling simulates a set of conditions by performing a series of equations or computer routines on set and inputted parameters (e.g., air quality or traffic monitoring data). You can purchase software to perform the modeling or create your own computer routine to model the data.



In the Paso del Norte Region, Caliper's TransCAD is used to generate traffic assignments and mode split analyses for city roadway networks. *Traffic assignments* are set model choices used to develop traffic flows based on cost models. *Mode split* analyses address transportation mode choices based on changing factors (e.g., if you increase fares, transit riders may choose other modes of transportation). Information obtained using this model helps the public identify:

- The quickest routes to minimize time in cars.
- Alternative routes.
- Alternative modes of transportation (e.g., bus routes).

The TransCAD model also is used to generate estimates of vehicle emissions.

## 4.4 LESSONS LEARNED FROM THE PASO DEL NORTE ENVIRONMENTAL MONITORING PROJECT

### INDUSTRY STANDARDS ARE CRITICAL

For the Paso del Norte Project, communicating timely environmental information is a technical challenge that requires multiple organizations and systems to share data and applications. Effective communication between systems is possible when data management applications support industry standards. Using industry standards for processing and managing data also makes it easier to address database problems and expands the potential for packaging information.

For the Paso del Norte Project, applications that support Open Database Connectivity (ODBC), traditional FTP, and Java (cross platform) programming languages were the easiest to design and implement. Parsing data into an ODBC relational database is relatively straightforward, and developing customized applications for presenting information in a database provides a robust solution that can grow with new ideas and opportunities. More important is the understanding that organizations that use industry standards can quickly provide ongoing support of developed applications. Finally, using industry standards establishes a foundation for collaborative development among other institutions and organizations that support the resulting information system.

Currently, environmental data collection and management systems inherently are proprietary, and limit collection and processing to the features requested by the client agency. The ability to capture data and process them so that they can be used by decision-makers such as elected officials is difficult without the use of industry standards. If industry standards are not used, the number and complexity of the steps required to collect and process data increases dramatically. As a result, the initial investment of time and resources is greater. More important is the loss of reliability due to increased chances for things to go wrong.

For the Paso del Norte Project, every effort was made to use industry standards with regional database technologies as the warehouse for data so that Java, Internet programs, and custom applications could be used to access the data. Having the data accessible via the Internet provides the foundation for an "enterprise" approach to processing and communicating environmental data collected in the Paso del Norte international region.

## **DELIVERY SYSTEM FOR ENVIRONMENTAL INFORMATION**

Complex environmental information must be processed into simple and easy-to-understand formats. Maps, graphics, charts, and tables must be designed carefully so they can be understood quickly, and the information they contain must be current and accurate. This is particularly true when the information is provided to broadcast media and to newspapers.

Broadcast companies have to meet rigid schedules for their daily news and weather broadcasts. For this reason, the ease with which they can obtain accurate and easy-to-understand environmental information dictates whether they will use the information. Level of technical expertise also plays a role in whether the broadcast media will use information: if they can use their existing technology, they are more likely to report the information. Because operating systems and communication capabilities vary among the broadcast companies, the approach used to provide a company with environmental information might have to be customized. You can do this by visiting each company to learn about its capabilities and then designing your communication system to be compatible.

## **COORDINATION AMONG PROJECT PARTNERS**

In a complex, multi-task project such as the Paso del Norte Environmental Monitoring Project, close coordination among the project partners is essential. This is even more important when several jurisdictions in different countries are involved. The project team should include at least one member with expertise in each field, and a team leader has to be assigned for each task. The team leader must assign tasks and follow up to ensure that they are completed. In addition, the entire project team must meet periodically, and follow-up is needed to ensure that actions discussed at the meetings are completed. As issues arise, the project team must meet to discuss and resolve them. It is also important that project members work together to share information, to brainstorm solutions to issues, and to complete the project tasks. A collaborative relationship between the project team and the responsible organizations is extremely important for the successful completion of a project.

## **INTERNATIONAL COMMUNICATIONS POSE THE GREATEST CHALLENGE**

Costs of international telecommunications are prohibitive. Public Internet access also poses a problem because the quality of service for Internet access varies significantly. For these reasons, radio and microwave communications are the best infrastructure for transmitting data between countries. However, the ability to integrate radio and microwave communications with local area networks varies among agencies. In the Paso del Norte Project, the City of El Paso and the universities were able to establish communications. Other partners were not, and had to depend on outside professional services for communication. This delayed the project. The project team had to use its technical expertise to address the communications issues of all of the project partners.

## **SUSTAINING THE PROJECT**

By focusing on collaboration, leveraging, and automation, the Paso del Norte Project can be sustained after the EMPACT grant period has ended.

Federal, state, and local agencies that provide environmental, health, and transportation information to the public have supported the Paso del Norte Project since the project was initiated. This support is expected to continue because many of the tools (e.g., relational database technologies and GIS) developed in the Paso del Norte Project can be transferred directly to information systems managed by these agencies, including the TransVista Traffic Management Center, TCEQ's Meteostar environmental monitoring network, and regional GIS mapping initiatives. As a result, regional cooperation is expected to continue, and application of the Paso del Norte tools is expected to increase. Probably the most significant accomplishment of the Paso del Norte Project is the establishment of a comprehensive regional approach to regional challenges, facilitated through sharing of technology and improved communications.

Leveraging of the Paso del Norte Project is resulting in unexpected investments that will help ensure the continuation of the project. Future plans include integration of the Paso del Norte Mapping for Public Access Initiative into the project. This regional GIS initiative, which will give the public Internet access to live maps of El Paso, Cd. Juárez, and Doña Ana County, has added approximately \$2 million to the project's local funds. The Paso del Norte Project also is being expanded to include emergency preparedness and response capabilities. One reason these other programs are leveraging the Paso del Norte Project is that the logistics of complex working relationships, information security, and other challenges have already been addressed in the project.

Automation of information collection and data processing, including quality assurance, also is critical to the continuation of the Paso del Norte Project. During the project, data collection and processing was simplified so that they can be continued with a minimal investment. Minimizing the number of steps in a process increases its reliability and reduces the project's maintenance requirements. For example, transferring data needed to calculate the AQI from multiple sources to a centralized database eliminates redundancy and provides an efficient means to process the data, calculate the AQI, and disseminate the AQI to the public. The end result is an increase in capacities and lower overall costs for the daily routine tasks.

### **UNIVERSITIES PLAY A CRITICAL ROLE**

Through UTEP, the Paso del Norte Project leveraged the Community Scholars Program to get students involved in air quality issues in the Paso del Norte region. This makes future generations aware of the regional air quality issues and helps increase the resources that will be available when long-term environmental challenges in the region must be addressed.

Universities also are an important base of knowledge—knowledge they can use in further research to understand and solve required environmental problems. In addition, universities have experience collaborating on projects, can quickly establish systems for information exchange, and can develop approaches for accomplishing multi-disciplinary tasks or objectives. In the Paso del Norte Project, local universities have become hubs for data warehousing and for developing approaches to address the environmental issues of the region. For example, UTEP participation in Internet2, a high-bandwidth dedicated intranet among partnering institutions, provides critical infrastructure for the transfer of information across international boundaries.

## UNEXPECTED BENEFITS

There were several unexpected benefits from the Paso del Norte Project.

In one case, a student completed a thesis for a masters degree in environmental engineering that addressed the use of GIS as a base for a comprehensive emission inventory within an international region.

In another case, the Army Research Laboratory (ARL) at the White Sands Missile Range partnered with UTEP to use the expanded real-time meteorological information and GIS base to develop a microscale diffusion model that improves the accuracy of plume models of accidental or intentional hazardous materials spilled in an international, urban setting. As a result, ARL donated a radiometer along with computers and software that will be used to collect real-time vertical temperature and moisture profiles of the atmosphere. Future research with the radiometer will help define critical conditions during temperature inversions that cause episodic air quality issues.

Access to near real-time environmental and meteorological information has peaked the interest of emergency response agencies including EMS 911 and police and fire departments. This has provided an opportunity to establish a secure intranet site to expand information access to remote offices and to other agencies currently not connected directly to the 911 system.

Animations of ozone and carbon monoxide have spurred new health research that considers the spatial distribution of air quality impacts. The Center for Border Health Research, a subsidiary of the Paso del Norte Health Foundation (sponsor of the Paso del Norte Mapping for Public Access Initiative) has made available the Texas public hospital discharge database, which documents demographic and diagnostic information from individual hospital encounters by ZIP code for the period 1999 to 2000. These data, in conjunction with the air quality information from the Paso del Norte Project, are being used in several epidemiological studies, and serve as the core information for collaborative research grant proposals to the National Institutes of Health and other entities.

# 5 DEPICTING TIMELY ENVIRONMENTAL INFORMATION

---

Now that you have collected, transferred, and managed your timely environmental information, you can turn to the next step in providing your community with the information: using data visualization tools to graphically depict the information. By using the data visualization tools described in this chapter, you can create graphic representations of environmental data that can be used on Web sites, in reports and educational materials, and in other outreach and communication initiatives.

Section 5.1 provides an overview of data visualization. Section 5.2 introduces the data visualization tools used by the Paso del Norte project team. If you are interested in a basic introduction to data visualization, you may want to read only Section 5.1. If you are responsible for choosing and using data visualization software to model and analyze data, you also should read Section 5.2.

## 5.1 WHAT IS DATA VISUALIZATION?

In this handbook, “data visualization” is graphic representation of data. Presenting data in a visual format can enhance your audience’s understanding of and interest in the information. Data visualization tools discussed below include maps, color coding, icons, graphs, and geographic information systems (GIS).

- **Maps.** Maps are one of the most basic and familiar data visualization tools that can be used to communicate timely environmental information. If kept simple (e.g., clutter-free) and accompanied by a good key that explains the different map symbols, a map can be one of the easiest data interpretation and visualization tools to develop and use.
- **Color coding.** Like maps, color coding is already familiar to many people. Thus its message can be easily understood. Colors to indicate “good” or “poor” environmental conditions (and ranges between those extremes) have been used successfully in maps, graphs, indexes, icons, and other tools for risk communication. Make sure to choose appropriate colors (and color ranges): use well-known color coding schemes, such as green to represent “go” (e.g., “it’s OK to go hiking based on air quality conditions”) and red to represent “stop” (e.g., “stay indoors particularly if you have a respiratory problem”).
- **Icons.** The term “icon” is used here in a very general sense to describe any visual cue or image used to communicate information—anything from a physical placard (e.g., a beach closure symbol or sign) to a symbol on a computer screen. Although words can be added, an icon ideally should be able to convey at least its basic meaning without relying on verbal language.
- **Graphs.** Graphs are another commonly used and relatively easy-to-understand data visualization tool. They often convey information about how several variables are related or compare to each other. Some projects allow users to generate graphs as needed by specifying which variables they want plotted and how they would like them plotted.



- **GIS.** A GIS is an effective data visualization tool for displaying, analyzing, and modeling spatial or geographic information. GIS maps, animations, and two- and three-dimensional models can be generated after detailed data are input into the system. This is usually done by skilled staff in a process that can be labor-intensive and fairly expensive. Two key advantages of GIS are the ability to quickly overlay and view several different data layers simultaneously (such as open lands, water resources, and population) and the ability to view and compare different future scenarios (such as future land uses) and their possible impacts (e.g., on environmental resources).

By applying these tools to environmental information, you can help your community's residents gain a better understanding of the information. Once you begin using data visualization tools, you will immediately be impressed with their ability to model and analyze your data for a variety of purposes, from making resource management decisions to supporting public outreach and education efforts.

## 5.2 DATA VISUALIZATION TOOLS EMPLOYED IN THE PASO DEL NORTE ENVIRONMENTAL MONITORING PROJECT

The Paso del Norte Project uses several data visualization tools to communicate environmental information to the public. Examples include maps, color-coding, tables and charts, GIS, and live and static images of the Paso del Norte region.

### 5.2.1 MAPS

Animated maps are used on the Paso del Norte Web site to depict air quality with respect to both carbon monoxide and ozone (see Figures 5 and 6). They emulate a three-dimensional perspective, as though the Paso del Norte region were being viewed at an oblique angle from an airplane flying south of Cd. Juárez, Mexico. The maps provide an animated movie format, which local television stations can download for rebroadcast and which the public can view on the Internet. Text on the maps can be viewed in both English and Spanish.

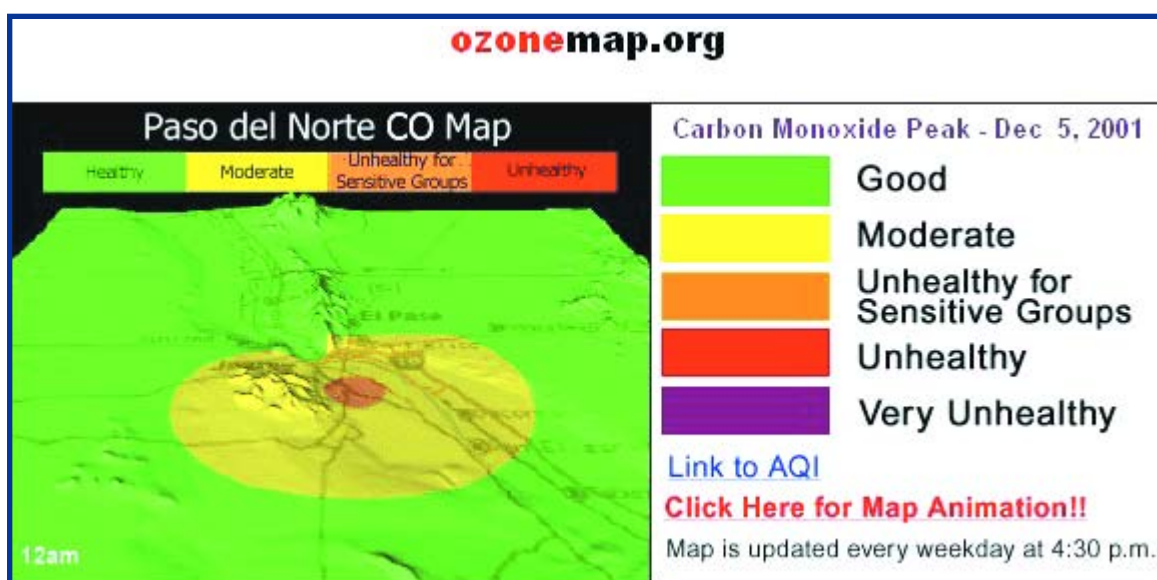

Figure 5. Paso del Norte animated carbon monoxide map.



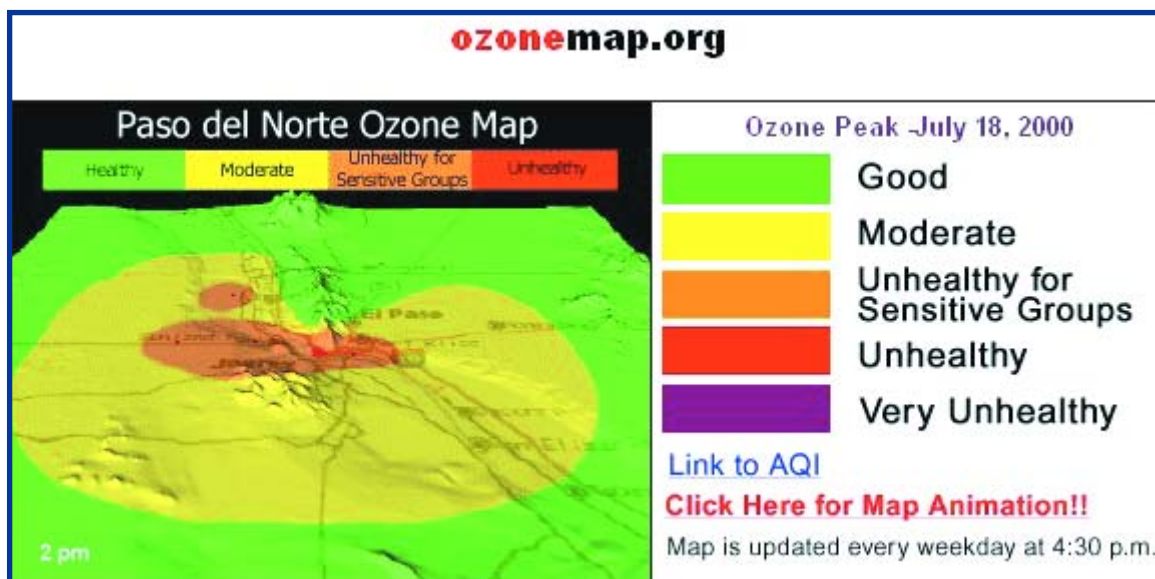

Figure 6. Paso del Norte animated ozone map.

Another map on the Web site for the Paso del Norte Environmental Monitoring Project is a map of the United States that shows the current UV Index for the country. Colors are used to show how the value for the index varies. The Web site also contains information about the UV Index and what the values for the index mean.

### 5.2.2 COLOR CODING

Color coding is used on the Project Web site's U.S. map to indicate the value for the UV Index, on the animated maps of the Paso del Norte region to indicate air quality with respect to ozone and carbon monoxide, and on the Web page that presents the Air Quality Index for the region. The Web site also describes the condition represented by each color on the animated maps and the Air Quality Index (see the table below). This is particularly important because some people may not know what a color means. The colors used in the Paso del Norte Project are the same as the colors used to for the Air Quality Index nationally. This makes it easier for people who are not from the Paso del Norte region to understand the information communicated through the Paso del Norte Project.

AQI Color-Coding System	Health Risk	Description
Green	Good	No limitations on outdoor exertion.
Yellow	Moderate	Unusually sensitive people should consider limiting prolonged outdoor exertion.
Orange	Unhealthy to sensitive groups	Active children, adults, and people with respiratory disease (such as asthma) should limit prolonged outdoor activity.
Red	Unhealthy	Active children, adults, and people with respiratory disease, such as asthma, should avoid prolonged outdoor exertion; everyone else, especially children, should limit prolonged outdoor exertion.
Purple	Very unhealthy	Active children, adults, and people with respiratory disease, such as asthma, should avoid all outdoor exertion; everyone else, especially children, should limit outdoor exertion.

In addition, the Project Web site discusses the relationship between the color codes and the numerical values used in conjunction with those codes. For example, on the Web site for the Air Quality Index, the reader is directed to “click here” for more information on the numerical value for the index. The Web site also discusses the numerical values for the ground-level ozone and CO levels.

### 5.2.3 TABLES AND CHARTS

Tables and charts are used on the Paso del Norte Project Web site to report various information. Examples include weather conditions, the latest wait times at the international bridges (see Figure 7), trends in weather data, and the relationship between the value for the Air Quality Index for a pollutant and the color codes.

Bridge	Hours	Minutes	Lanes Open	Last Updated at:
Americas-Lincoln	0	50	11 of 11 total	01-May-02 7:22:42 a.m.
Americas-Perez Serna	0	50	11 of 11 total	01-May-02 7:22:55 a.m.
DCL-Stanton	0	10	1 of 1 total	01-May-02 7:23:04 a.m.
Paso del Norte	0	20	10 of 10 total	01-May-02 7:23:13 a.m.
Ysleta	0	3	13 of 13 total	01-May-02 8:02:21 a.m.
Sta. Teresa	0	0	2 of 2 total	26-Mar-02 6:37:02 a.m.
Fabens	0	0	2 of 2 total	21-Mar-02 7:34:37 a.m.

Figure 7. International bridge crossing wait times.

### 5.2.4 GEOGRAPHIC INFORMATION SYSTEM

An industry standard GIS-based transportation model, TransCAD, is used to visualize traffic volumes in the Paso del Norte region. The model predicts and displays the impact on traffic volumes and levels of service from construction activities, accidents, and other roadway impedances. This information helps commuters and emergency response personnel avoid congested areas. It also estimates vehicle emissions in the area based on traffic volume data.

### 5.2.5 LIVE AND STATIC IMAGES

Live and static images are provided by the Paso del Norte webcam system (see Figure 8). These images allow researchers, community leaders, and the citizens of the Region to see how air quality affects visibility. By actually seeing the impact of air pollution, those groups are encouraged to learn more about what they can do to improve air quality.



Figure 8. Visibility webcam images.

# 6

## COMMUNICATING TIMELY ENVIRONMENTAL INFORMATION

---

As your community develops its near real-time environmental monitoring and reporting systems, you need to think about the best ways to communicate the information these systems yield. This chapter is designed to help you do that. It outlines the steps involved in developing an outreach plan (Section 6.1), and it profiles the outreach initiatives implemented by the Paso del Norte project team (Section 6.2). It also provides guidelines for effectively communicating information, and contains examples of text that you can incorporate into your own communication and outreach materials (Section 6.3).

### 6.1 CREATING AN OUTREACH PLAN FOR NEAR REAL-TIME ENVIRONMENTAL DATA

Outreach is most effective if you plan it carefully: Whom do you want to reach? What information do you want to disseminate? What are the most effective mechanisms to reach people? Developing a plan ensures that you consider all important elements of an outreach project before you begin. The plan itself provides a blueprint for action.

An outreach plan is most effective if you involve a variety of people in its development. Where possible, consider involving:

- A communications specialist or someone who has experience developing and implementing an outreach plan.
- Technical experts in the subject matter (both scientific and policy).
- Someone who represents the target audience (i.e., the people or groups you want to reach).
- Key individuals who will be involved in implementing the outreach plan.

As you develop your outreach plan, consider whether you would like to invite any organizations to partner with you in planning or implementing the outreach effort. Partners might include local businesses, environmental organizations, schools, local health departments, local planning and zoning authorities, and other local or state agencies. Partners can participate in planning, product development and review, and distribution. Partnerships can be valuable mechanisms for leveraging resources while enhancing the quality, credibility, and success of outreach efforts.

Developing an outreach plan is a creative and iterative process involving a number of inter-related steps, as described below. As you move through each of these steps, you might want to revisit and refine the decisions you made in earlier steps until you have an integrated, comprehensive, and achievable plan.

An outreach plan does not have to be lengthy or complicated. You can develop a plan simply by documenting your answers to each of the questions discussed below. This will provide you with a solid foundation for an outreach effort.

## WHOM ARE YOU TRYING TO REACH?

### *Identifying Your Audience(s)*

The first step in developing an outreach plan is to clearly identify your target audience or audiences. The goals of your outreach program often define their target audiences. You might want to refine and add to your goals after you have specifically considered which audiences you want to reach.

Target audiences for an outreach program for environmental information might include the general public, local decision-makers, land management agencies, educators and students (high school and college), and special interest groups (e.g., homeowner associations). Some audiences, such as educators and special interest groups, might serve as conduits to help disseminate information to other audiences you have identified, such as the general public.

Consider whether you should divide the public into two or more audience categories. For example: Will you be providing different information to certain groups, such as citizens and businesses? Does a significant portion of the public you are trying to reach have a different cultural or linguistic background from other members? If so, it likely will be most effective to consider these groups as separate audience categories.

### *Profiling Your Audience(s)*

Outreach is most effective if the type, content, and distribution of outreach products are tailored specifically to the characteristics of target audiences. Once you have identified your audiences, the next step is to develop a profile of their situations, interests, and concerns. This profile helps you identify the most effective ways of reaching the audience. For each target audience, consider:

- What is their current level of knowledge?
- What do you want them to know?
- What information is likely to be of interest to the audience? What will they likely want to know once they develop some awareness of environmental issues?
- How much time are they likely to give to receiving and assimilating the information?
- How does this group generally receive information?
- What professional, recreational, and domestic activities does this group typically engage in that might provide avenues for distributing outreach products? Are there any organizations or centers that represent or serve the audience and might be avenues for disseminating your outreach products?

Profiling an audience essentially involves putting yourself “in your audience’s shoes.” Ways to do this include consulting individuals or organizations who represent or are members of the audience, consulting other agencies or individuals who have successfully developed other outreach products for the audience, and using your imagination.

## WHAT ARE YOUR OUTREACH GOALS?

Defining your outreach goals is the next step in developing an outreach plan. Outreach goals should be clear, simple, action-oriented statements about what you hope to accomplish through outreach. Once you have established your goals, every other element of the plan should relate to them.

## WHAT DO YOU WANT TO COMMUNICATE?

With your audience and goals identified, you should think about what you want to communicate. In particular, think about the key points, or “messages,” you want to communicate. Messages are the “bottom line” information you want your audience to walk away with, even if they forget the details.

A message usually is phrased as a brief (often one-sentence) statement. For example:

- The Air Quality Index allows you to track daily changes in air quality.
- The Air Quality Index helps you decide whether to participate in outdoor activities.

Outreach products often have multiple related messages. Consider what messages you want to send to each target audience group. You might have different messages for different audiences.

## WHAT OUTREACH PRODUCTS WILL YOU DEVELOP?

The next step in developing an outreach plan is to consider what types of outreach products are the most effective for reaching each target audience. There are many different types of outreach product: print, audiovisual, electronic, events, and novelty items. Some examples are provided below.

Type of Outreach Product	Examples of Outreach Products	
Print	Brochures Educational curricula Question-and-answer sheets Press releases Book covers	Editorials Fact sheets Posters Utility bill inserts Newspaper and magazine articles
Audiovisual	Cable television Videos	Public service announcements (radio) Exhibits and kiosks
Electronic	E-mail messages Web pages	Subscriber list servers
Events	Briefings Fairs and festivals One-on-one meetings Public meetings	Community days Media interviews Press conferences Speeches
Novelty Items	Banners Buttons Floating key chains Magnets	Bumper stickers Coloring books Frisbee discs Mouse pads

The audience profile information you assembled earlier will help you select appropriate products. A communications professional can provide valuable guidance in choosing the most appropriate products to meet your goals within your resource and time constraints. Questions to consider when selecting products include:

- How much information does your audience really need to have? How much does your audience need to know now? The simplest, most effective, most straightforward product generally is most effective.
- Is the product likely to appeal to the target audience? How much time does it take to interact with the product? Is the audience likely to make that time?
- How easy and cost-effective is the product to distribute or, in the case of an event, organize?



- How many people is this product likely to reach? For an event, how many people are likely to attend?
- What time frame is needed to develop and distribute the product?
- How much does it cost to develop the product? Do you have access to the talent and resources needed for development?
- What other related products are already available? Can you build on existing products?
- When will the material be out of date? (You probably will want to spend fewer resources on products with short lifetimes.)
- Is it effective to have distinct phases of products over time? For example, a first phase of products designed to raise awareness, followed at a later date by a second phase of products to encourage changes in behavior.
- How newsworthy is the information? Information with inherent news value is more likely to be rapidly and widely disseminated by the media.

### HOW WILL YOUR PRODUCT REACH YOUR AUDIENCE?

Effective distribution is essential to the success of an outreach strategy. There are many avenues for distribution. Some examples are listed below.

Examples of Distribution Avenues	
Your mailing list	TV
Partner's mailing list	Radio
Phone/Fax	Print media
E-mail	Hotline that distributes products on request
Internet	Meetings, events, or locations (e.g., libraries, schools, marinas, and public beaches) where products are made available
Journals or newsletters of partner organizations	

You need to consider how each product is distributed and determine who is responsible for distribution. For some products, your organization might manage distribution. For others, you might rely on intermediaries (such as the media or educators) or organizational partners who are willing to participate in the outreach effort. Consult with an experienced communications professional to obtain information about the resources and time required for the various distribution options. Some points to consider in selecting distribution channels include:

- How does the audience typically receive information?
- What distribution mechanisms has your organization used in the past for this audience? Were these mechanisms effective?
- Can you identify any partner organizations that might be willing to assist in the distribution?
- Can the media play a role in the distribution?
- Will the mechanism you are considering reach the intended audience? For example, the Internet can be an effective distribution mechanism, but certain groups might have limited access to it.



- How many people is the product likely to reach through the distribution mechanism you are considering?

### **WHAT FOLLOW-UP MECHANISMS WILL YOU ESTABLISH?**

With a successful outreach program, the targeted audience may request further information. Consider whether and how you will handle this interest. The following questions can help you develop this part of your strategy:

- What types of reactions or concerns are audience members likely to have in response to the outreach information?
- Who will handle requests for additional information?
- Do you want to indicate on the outreach product where people can go for further information (e.g., provide a contact name, number, mailing or office address, e-mail address, or Web address)?

### **WHAT IS THE SCHEDULE FOR IMPLEMENTATION?**

Once you have decided on your goals, audiences, messages, products, and distribution channels, you need to develop an implementation schedule. For each product, consider how much time is needed for development and distribution. Be sure to factor in sufficient time for product review. Wherever possible, build in time for testing and evaluation by members or representatives of the target audience in focus groups or individual sessions so that you can get feedback on whether you have effectively targeted your material for your audience. Section 6.3 contains suggestions for presenting technical information to the public. It also provides information about online resources that provide easy-to-understand background information you can use in developing your own outreach projects.

## **6.2 ELEMENTS OF THE PASO DEL NORTE ENVIRONMENTAL MONITORING PROJECT OUTREACH PROGRAM**

The Paso del Norte project team uses a variety of mechanisms to communicate timely environmental information to the public. Elements of the Project's outreach program are highlighted below.

*Web site.* The Paso del Norte Environmental Monitoring Project Web site (<http://www.ozonemap.org>) is the main vehicle through which timely environmental information is conveyed to the public. The site contains the current conditions in the region with respect to several air pollutants (e.g., ground-level ozone and carbon monoxide), traffic, and weather. It also contains health facts on air pollutants, animated ozone and carbon monoxide maps of the region, the current Air Quality Index for the region, and current traffic images from cameras located throughout the region. In addition, it contains live and static images that allow the public to see how air quality affects visibility in the Paso del Norte region. The Web site also encourages people to report smoking vehicles and identifies a person to contact to obtain information. Information on the Web site is presented in both English and Spanish. Figure 9 shows the site's home page.



Figure 9. Home page for Paso del Norte Web site.

*Community Scholars Program.* The Community Scholars Program is a non-profit summer internship program funded primarily by grants from local businesses and individual contributors. It is designed to foster leadership skills by involving El Paso high school honor students directly in researching solutions to the City's social and civic problems. Through a competitive process, the program hires junior and senior honor students from 14 local high schools. Student interns undergo 40 hours of after-school training in May, then begin full-time research at the University of Texas at El Paso during the summer months. This program allows the students to focus on key environmental issues and develop materials appropriate for educating the public about those issues. One such issue is air pollution.

As part of the Paso del Norte Environmental Monitoring Project, 15 laptop computers were purchased and placed in the home schools of the students. The computers are equipped with Web development software, geographic information systems, standard office applications, and Internet access. This allows the Community Scholars Program to extend research on air pollution initiated by the summer interns throughout the school year. It also allows the interns to encourage other students to become involved in educational activities that promote a better understanding of air pollution and the effects of meteorology, terrain, and emission sources in the bi-national Paso del Norte region.

The home page for the Community Scholars Program is shown in Figure 10.



Figure 10. Home page for the Community Scholars Program

**Book covers.** As part of the Paso del Norte Environmental Monitoring Project, 45,000 book covers were purchased and distributed to students. The cover contains important health information about ozone as well as information on the animated ozone map on the Paso del Norte Project Web site.

**Television.** All of the local broadcast affiliates broadcast air quality and related health information, including announcements of ozone action days, during their evening broadcasts. Visualizations of the ozone conditions are made available to the broadcast media through FTP over the Internet. Ozone action days and suggestions are also announced on the electronic signs that are part of the TransVista Intelligent Transportation System.

Channel 56 includes a daily “bump,” a short animation that summarizes the critical environmental conditions, during its nightly weather report. Each afternoon, a Web page is built that announces current environmental conditions and gives a forecast of air quality for the following day. The Web page is customized to meet the design requirements of Channel 56. Channel 56 captures the image through a secure intranet site and imports it into its AccuWeather system for broadcast (see Figure 11).

**Ozone action days.** The Paso del Norte Environmental Monitoring Project Web site includes an “Ozone Action Days” page (see Figure 11). This page describes an ozone action day, provides information on how to protect yourself on such days, and provides recommendation on what not to do (e.g., driving at lunchtime) on an ozone action day. It also allows someone to sign up for the ozone action day notification list server. Subscribers to this list-server are notified when there is an ozone action day.



Figure 11. “Bump” used by Spanish television.

*Digital readouts.* Digital readouts are used in the Paso del Norte Environmental Monitoring Project to provide information on traffic conditions. The information, including bridge wait times, is presented on billboards located in strategic areas of the region.

### 6.3 RESOURCES FOR PRESENTING ENVIRONMENTAL INFORMATION TO THE PUBLIC

As you begin to implement your outreach plan and develop the products selected in the plan, make sure that these products present your messages and information as clearly and accurately as possible. You might want to review the available resources on the Internet—see if any can help you develop your outreach products or serve as additional resource materials (e.g., fact sheets).

#### HOW DO YOU PRESENT TECHNICAL INFORMATION TO THE PUBLIC?

Environmental topics are often technical in nature, and air quality is no exception. Nevertheless, this information can be conveyed in simple, clear terms to nonspecialists, such as the public. Principles of effective writing for the public include avoiding jargon, translating technical terms into everyday language the public can understand, using the active voice, keeping sentences short, and using headings and other format devices to provide a very clear, well-organized structure. You can refer to the following Web sites for more ideas about how to write clearly and effectively for a general audience:



- The National Partnership for Reinventing Government has developed a guidance document, *Writing User-Friendly Documents*, that can be found on the Web at <http://www.plainlanguage.gov/>.
- The Web site of the American Bar Association (<http://www.abanet.org/>) has links to important online style manuals, dictionaries, and grammar primers.

As you develop communication materials for a specific audience, remember to consider what the audience members are already likely to know, what you want them to know, and what they are likely to understand. Then tailor your information accordingly. Provide only information that is valuable and interesting to the target audience. For example, environmentalists in your community might be interested in the details of the Air Quality Index. But it's not likely that school children will be interested in this level of detail.

When developing outreach products, be sure to consider special needs of the target audience. For example, if your community has a substantial number of people who speak little or no English, you may need to prepare communication materials in their native language. This is particularly true for the Paso del Norte region because both English and Spanish are spoken there.

The rest of this section contains examples of text about ozone, carbon monoxide, particulate matter, and the air quality index. These examples are written in a plain-English style designed to be easily understandable by the public. You can use this text as a model to stimulate ideas for your own outreach language or you can incorporate components of this text directly into your products.

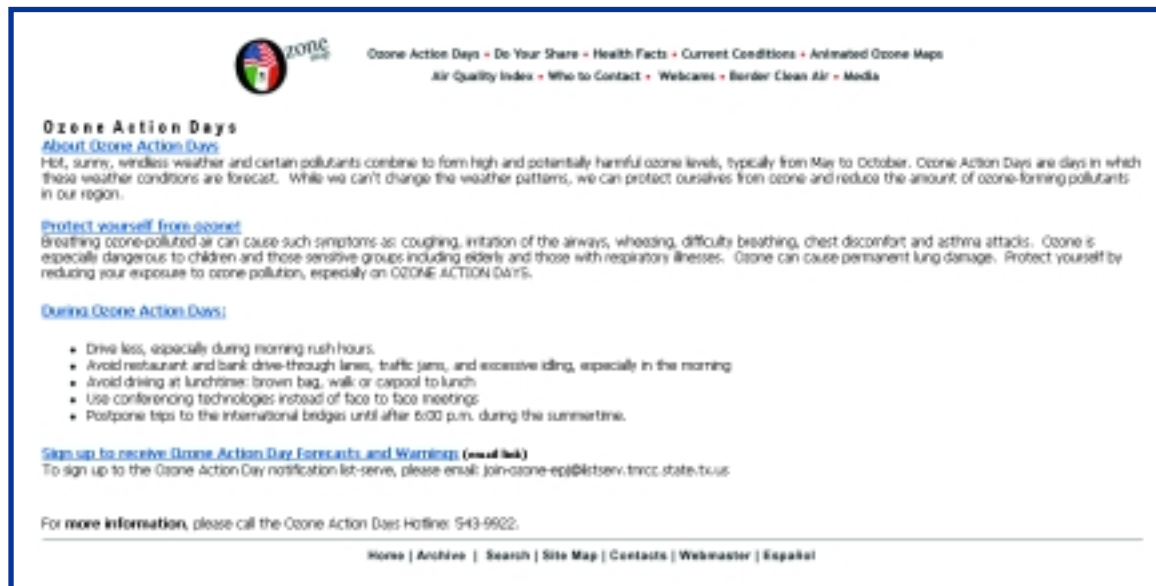

Figure 12. Ozone Action Days page.

## OZONE POLLUTION

- *What is ozone?*

Ozone is an odorless, colorless gas composed of three atoms of oxygen.

- *Is ozone good or bad for people's health and the environment?*

Ozone occurs both in the Earth's upper atmosphere and at ground level. Ozone can be good or bad depending on where it is found.

- *Good ozone.* Ozone occurs naturally in the Earth’s upper atmosphere—10 to 30 miles above the Earth’s surface—where it forms a protective barrier that shields people from the sun’s harmful ultraviolet rays. This barrier is sometimes called the “ozone layer.”
- *Bad ozone.* Because of pollution, ozone also is found in the Earth’s lower atmosphere, at ground level. Ground-level ozone is a major ingredient of smog and it can harm people’s health by damaging their lungs. It also can damage crops and many common man-made materials, such as rubber, plastic, and paint.

EPA’s booklet *Ozone: Good Up High, Bad Nearby* (found on the Web at <http://www.epa.gov/oar/oaqps/gooduphigh>) contains additional information about both good and bad ozone.

- *How is ground-level ozone formed?*

Ground-level ozone is not emitted directly into the air but forms when two kinds of pollutants—volatile organic compounds and nitrogen oxides—mix in the air and react chemically in the presence of sunlight. Common sources of volatile organic compounds (often referred to as VOCs) include motor vehicles, gas stations, chemical plants, and other industrial facilities. Solvents such as dry-cleaning fluid and chemicals used to clean industrial equipment are also sources of VOCs. Common sources of nitrogen oxides include motor vehicles, power plants, and other fuel-burning sources.

- *Are there times of the day and year when ozone pollution is of particular concern?*

Yes. Ozone levels vary during the day. They are highest in the late afternoon and decrease rapidly at sunset.

In most parts of the United States, ozone pollution is likely to be a concern during the summer months, when the weather conditions needed to form ground-level ozone—lots of sun, hot temperatures—occur. Ozone pollution is usually at its worst during the summer heat waves when air masses are stagnant.

- *In what way can ozone affect people’s health?*

Ozone can affect people’s health in many ways:

- *Ozone can irritate the respiratory system.* When this happens, you might start coughing, feel an irritation in your throat, or experience an uncomfortable sensation in your chest. These symptoms can last for a few hours after exposure to ozone and may even become painful.
- *Ozone can reduce lung function.* When scientists refer to “lung function,” they mean the volume of air that you draw in when you take a full breath and the speed at which you are able to blow out the air. Ozone can make it more difficult for you to breathe as deeply and vigorously as you normally would.
- *Ozone can aggravate asthma.* When ozone levels are high, more asthmatics have asthma attacks that require a doctor’s attention or the use of additional asthma medication.
- *Ozone can aggravate chronic lung diseases,* such as emphysema and bronchitis.
- *Ozone can inflame and temporarily damage the lining of the lung.* Ozone damages the cells that line the air spaces in the lung. Within a few days, the damaged cells are replaced and the old cells are shed. If this kind of damage occurs repeatedly, the lung can change permanently in a way that could cause long-term health effects.



- *Who is sensitive to ozone?*
  - *Children.* Active children are the group at highest risk from ozone exposure. Such children often spend a large part of their summer vacation outdoors, engaged in vigorous activities. Children also are more likely to have asthma or other respiratory illnesses, which can be aggravated by exposure to ozone.
  - *Adults who are active outdoors.* Healthy adults who exercise or work outdoors are considered a “sensitive group” because they have a higher level of exposure to ozone than people who are less active outdoors.
  - *People with respiratory diseases, such as asthma.* There is no evidence that ozone causes asthma or other chronic respiratory disease, but these diseases do make the lungs more vulnerable to the effects of ozone.
  - *People with unusual susceptibility to ozone.* Scientists don’t yet know why, but some healthy people are simply more sensitive to ozone than are others. These individuals may experience more health effects from exposure to ozone than does the average person.
  - *Are the elderly sensitive to ozone?* Scientists have found little evidence to suggest that either the elderly or people with heart disease have heightened sensitivity to ozone.

For additional information about the health effects of ozone you can read EPA’s booklet *Smog: Who Does It Hurt?* (found on the Web at <http://www.epa.gov/airnow/health>).

## CARBON MONOXIDE

- *What is carbon monoxide?*

Carbon monoxide is a odorless, colorless gas.

- *How is carbon monoxide formed?*

Carbon monoxide forms when the carbon in fuels does not burn completely.

- *How does carbon monoxide affect people’s health?*

Carbon monoxide enters the bloodstream and reduces oxygen delivery to the body’s organs and tissues. The health threat from carbon monoxide is most serious for those who suffer from cardiovascular disease. Healthy individuals are also affected, but only at higher levels of exposure. Exposure to elevated carbon monoxide levels is associated with visual impairment, reduced work capacity, reduced manual dexterity, poor learning ability, and difficulty in performing complex tasks.

- *What are the sources of carbon monoxide?*

Vehicle exhaust contributes roughly 60 percent of all carbon monoxide emissions nationwide, and up to 95 percent in cities. Carbon monoxide concentrations typically are highest during cold weather because combustion is less complete in cold temperatures.

For additional information about carbon monoxide, refer to the EPA Web site at <http://www.epa.gov/air/oaqps/>.

## PARTICULATE MATTER

- *What is particulate matter?*

Particulate matter includes both solid particles and liquid droplets found in air.

- *How is particulate matter formed?*

Many man-made and natural sources emit particulate matter directly to the air or emit pollutants that react in the atmosphere to form particulate matter.

- *What is the size of particulate matter?*

Solid and liquid particles come in a wide range of sizes. Particles less than 10 micrometers in diameter (PM<sub>10</sub>) tend to pose the greatest health concern. Particles less than 2.5 micrometers in diameter (PM<sub>2.5</sub>) are referred to as “fine” particles. Sources of fine particles include all types of combustion process (e.g., power plants) and some industrial processes. Particles with a diameter between 2.5 and 10 micrometers are referred to as “coarse.” Sources of coarse particles include grinding operations and dust from paved or unpaved roads.

- *What are the health effects from exposure to particulate matter?*

When exposed to particulate matter, people with heart or lung disease (e.g., congestive heart disease, coronary artery disease, asthma, or chronic obstructive pulmonary disease) are at increased health risk. People with heart disease may experience symptoms such as chest pain, palpitations, shortness of breath, and fatigue. Symptoms for people with lung disease include coughing, phlegm, chest discomfort, wheezing, and shortness of breath. Even healthy people may experience some respiratory systems from exposure to particulate matter. Children are at increased risk of experiencing respiratory symptoms from exposure to particulate matter because they are more active outdoors and are more likely to have asthma. Particles with a diameter less than 10 micrometers tend to pose the greatest health risk because they can be inhaled into and accumulate in the respiratory system.

For additional information about particulate matter you can refer to the EPA’s Office of Air Quality Planning and Standards Web site at <http://www.epa.gov/air/oaqps/>.

## AIR QUALITY INDEX

- *What is the Air Quality Index?*

The Air Quality Index (AQI) is a tool developed by EPA to provide people with timely and easy-to-understand information on local air quality and whether it poses a health concern. It provides a simple, uniform system that is used throughout the country for reporting levels of major pollutants regulated under the Clean Air Act (CAA).

Pollutants include ground-level ozone, carbon monoxide, sulfur dioxide, particulate matter, and nitrogen oxide. You may sometimes hear the AQI referred to as the Pollutant Standards Index.

The AQI converts a measured air concentration for a pollutant to a number on a scale of 0 to 500. An AQI value of 100 corresponds to the National Ambient Air Quality Standard established for the pollutant under the CAA. This is the level or concentration that EPA has determined to be protective of human health. The higher the index value, the greater the health concern.

- *What do the Air Quality Index descriptors mean?*

As shown below, the Air Quality Index scale is divided into six categories, each corresponding to a different level of health concern. Each category also is associated with a color.

AQI Color-Coding System	Health Risk	Description
Green	0 to 50	Good
Yellow	51 to 100	Moderate
Orange	101 to 150	Unhealthy for sensitive groups
Red	151 to 200	Unhealthy
Purple	201 to 300	Very unhealthy
Maroon	301 to 500	Hazardous

The level of health concern associated with each AQI category is summarized by a descriptor:

*Good.* When the AQI value for your community is between 0 and 50, air quality is considered satisfactory in your area.

*Moderate.* When the index value for your community is between 51 and 100, air quality is acceptable in your area. For ozone and fine particles, people who are extremely sensitive may experience respiratory symptoms.

*Unhealthy for sensitive groups.* When AQI values are between 101 and 150, members of sensitive groups may experience health effects. Some people are particularly sensitive to the harmful effects of certain pollutants. For example, people with asthma may be sensitive to sulfur dioxide and ozone, while people with heart disease may be sensitive to carbon monoxide. Some groups of people may be sensitive to more than one pollutant. Members of the general public are not likely to be affected when the AQI is in this range.

*Unhealthy.* When AQI values are between 151 and 200, everyone may begin to experience health effects. Members of sensitive groups may experience more serious health effects.

*Very unhealthy.* AQI values between 201 and 300 trigger a health effect for everyone.

*Hazardous.* AQI values over 300 trigger health warnings of emergency conditions. AQI values over 300 rarely occur in the United States.

- *How is the Air Quality Index calculated?*

State and local air quality monitoring networks measure the concentration of ground-level ozone, fine and coarse particulate matter, carbon monoxide, nitrogen dioxide, and sulfur dioxide several times a day. These raw measurements are then converted into corresponding AQI values using standard conversion scales developed by EPA. For example, an ozone measurement of 0.08 parts per million, which is the National Ambient Air Quality Standard for ozone, translates to an AQI of 100.

After the AQI values for the individual pollutants are calculated, they are used to calculate an overall single index value for the local area. One determines the single AQI value simply by taking the highest index value calculated for the individual pollutants. This value becomes the reported AQI for a community for the day. For example, say that on August 10, your community has an AQI of 115 for ozone and 72 for carbon monoxide. The AQI reported that day for your community is 115. On days when the AQI for two or more pollutants is greater than 100, the pollutant with the highest index level is reported, but information on any other pollutant above 100 also may be reported.

- *When and how is the Air Quality Index reported to the public?*

In metropolitan areas of the United States with populations over 350,000, state and local agencies are required to notify the public on days when the AQI for a pollutant exceeds 100. They also may report the AQI for all pollutants for which the index exceeds 100. Even in areas where reporting is not required, EPA, state, and local officials may use the AQI as a public information tool to advise the public about how local air quality might affect their health, and what actions they can take to protect their health. You may see the AQI reported in the newspaper or on the Internet, or it may be broadcast on your local television or radio station. In some areas, AQI information is available on a recorded telephone message.

More information about the AQI is available at <http://www.epa.gov/airnow/aqibroch/>.

# **7 SUSTAINING TIMELY ENVIRONMENTAL MONITORING INFORMATION**

---

**T**his chapter discusses how environmental monitoring can be sustained over time. This is necessary to insure that the public and interested groups continue to have the information.

The chapter begins with a discussion on using existing programs to collect timely environmental information (Section 7.1). It then discusses where to house the database and Web server for an environmental monitoring project (Section 7.2). Section 7.3 addresses public support for environmental monitoring, and Section 7.4 discusses the environmental information that can be collected given a certain level of funding.

## **7.1 BUILDING ON EXISTING PROGRAMS**

A key aspect of an environmental monitoring program is the ability to sustain the program over the long term. You can do this by building on existing programs whenever possible, by using existing infrastructure, and by using low-maintenance automated equipment to collect data. This approach reduces the funding needed to continue an environmental monitoring program and at the same time helps ensure full use of existing facilities.

As discussed in the previous sections, the Paso del Norte Environmental Monitoring Project leveraged several existing efforts. Information collected through these efforts includes:

- Air quality data (ozone, carbon monoxide, and particulate matter) collected by various agencies in Texas, New Mexico, and Mexico.
- Traffic volume data collected by the City of El Paso's Department of Traffic and Transportation and by the Texas Department of Transportation.
- International bridge crossing information provided by the U.S. Customs and Immigration Service. The Association of Maquilas also developed an infrastructure to provide timely information on the number of bridge crossings and observed wait times.
- Static and live images from a webcam and video images of current traffic conditions at various locations in the Paso del Norte region.
- Weather data obtained from the National Weather Service Web site.

Data from these existing programs are transferred to a database, managed, and displayed on the Web site for the Paso del Norte Environmental Monitoring Project.

As discussed in Chapter 6, the Paso del Norte Project also leverages the Community Scholars Program as part of its outreach efforts. Students enrolled in the program develop educational materials to promote the involvement of other high school students in the region's air pollution issues.

Another leveraged program is the Ozone Map Initiative. Austin College and the University of Texas at El Paso (UTEP) developed an animated ozone map of the region using data from the continuous air monitoring stations (CAMS) in the region. This map is displayed on the Paso del Norte Project Web site. As part of the Paso del Norte Environmental Monitoring Project, an animated map for carbon dioxide was prepared using the framework developed for the ozone animated map and carbon monoxide data collected at the CAMS.

In addition, the Paso del Norte Environmental Monitoring Project leveraged the resources of the Paso del Norte Air Quality Task Force, the Clean Air Partnership, the Paso del Norte Health Foundation, and members of the Joint Advisory Committee. The Joint Advisory Committee, which was established in 1997 by an amendment to Annex Five of the La Paz Agreement between the United States and Mexico, is an advisory body that addresses the binational air pollution problems in the region.

## **7.2 HOUSING YOUR DATABASE AND WEB SERVER**

The database and Web server for an environmental monitoring project can be located at several locations or at a single location. In deciding where to house your database and Web server, consider the advantages of one location. These include having to secure only one location, better administrative control, easier management, and less expense. In addition, fewer software and licensing agreements are needed when the database and Web server are housed at one location. One disadvantage is that redundancy has to be included at the single location. Housing the database and Web server at multiple locations provides this redundancy.

During the Paso del Norte Environmental Monitoring Project, the El Paso Metropolitan Planning Organization (MPO) housed a new Internet server to handle the bulk of public Internet access. UTEP housed a new Internet server to provide for time-lapse visualization of air quality on a three-dimensional GIS map and terrain model of the Paso del Norte air basin. UTEP also housed a new database management server.

At the completion of the Paso del Norte Environmental Monitoring Project, all of UTEP's equipment will be transferred to the City of El Paso and the El Paso City-County Health and Environment District (EPCCH) for ongoing implementation and maintenance. UTEP also will train City and EPCCH personnel on the use of the equipment.

## **7.3 PUBLIC SUPPORT**

Public support is needed to sustain an environmental monitoring program because it makes decision-makers aware of the desire to have such a program. This is important when decisions are made on funding for a project. Without public support, there is little to no impetus to either initiate or continue an environmental monitoring program.

Several organizations support the Paso del Norte Environmental Monitoring Project. These include EPCCH, El Paso MPO, the Texas Commission on Environmental Quality, the New Mexico Environmental Department, and the Institute of Municipal Planning and Research (Cd. Juárez). Other organizations that support the project include Austin College, UTEP, the KFOX television station, the Joint Advisory Committee, the Paso del Norte Air Quality Task Force, the Paso del Norte Health Foundation, and the Clean Air Partnership.

## **7.4 WHAT DATA TO COLLECT**

Data collected in a near real-time environmental monitoring program depend on the available funding. When funds are limited, determine the critical environmental parameters for an area and focus the monitoring effort on collecting data for those parameters. Consider any seasonal variation in the critical parameters when designing the monitoring program.

The critical air quality parameters for the Paso del Norte region are ground-level ozone, carbon monoxide, and particulate matter. For this reason, near real-time data are collected for these parameters. Data also are collected that have an impact on the air concentration of those parameters. These include traffic volume data, bridge crossing and wait time data, and weather data. All of these data are used to inform the public about air quality in the Paso del Norte region and to encourage them to take actions (e.g., don't drive on days when the ozone level is high) to improve air quality in the region.



## APPENDIX A

### CASE STUDY: TUCSON, ARIZONA, AIR INFO NOW PROJECT

#### ABOUT THE PROJECT

The Air Info Now program works to produce media and public communication programs about air quality, health concerns related to air pollution, and local solutions to improve air quality in the Tucson, Arizona, community. Tucson is located in Pima County, and the Pima County Department of Environmental Quality (PDEQ) leads the program. The program began in 1999 to address community concerns about air pollution and its effects on public health and the environment. The program goals are:

- To collect timely air quality information.
- To disseminate timely air quality information to the public.
- To expand the community's awareness of health and environmental effects that air pollution may cause.
- To address local air pollution problems.

Under this program, air quality samples are taken from 18 locations around the Tucson area. Monitored air parameters include ground-level ozone, carbon monoxide, and particulate matter. The Tucson area is an attainment area for all the criteria air pollutants. The area has been designated as a maintenance area for carbon monoxide.

#### PARTNER ORGANIZATIONS

PDEQ developed its Air Info Now Web site under a grant from EPA. The program also receives assistance from the University of Arizona, the American Lung Association, and the Pima Association of Governments.

#### COLLECTING AND MANAGING THE DATA

PDEQ maintains 18 monitoring locations throughout the Tucson area. Ground-level ozone is monitored at eight locations. Other monitored parameters include carbon monoxide and particulate matter. In addition to air quality, the monitors measure wind speed, wind direction, and ambient air temperature. The Web site provides further details on each monitoring location.

Like the Paso del Norte Environmental Monitoring Project, the Air Info Now Program needed to standardize the format of the data collected. The University of Arizona and PDEQ established a standard format that allows data to be used in near real-time mapping applications.

PDEQ performs quality assurance/quality control on the air monitoring data using the standard practices defined in 40 CFR Part 58, Ambient Air Quality Surveillance (available online at <http://www.access.gpo.gov/nara/cfr/cfr-table-search.html#page1>). They include standard operating procedures for data collection, sample analysis, and data processing. They also include defined calibration and performance test schedules, and tolerances not to be exceeded.

PDEQ uses a Microsoft (MS) NT Server to display the air quality monitoring data on the program's Web site. To convert the air quality monitoring data to a Web-compatible format, PDEQ wrote computer macros for MS-DOS batch files and MS Excel, Access, and Visual Basic programs to convert the hourly air quality monitoring data from the proprietary Data Management System file structure to MS Access database tables. The data then can be accessed via Open Database Connectivity (ODBC), which pulls data out for Web page displays. PDEQ also developed computer routines to create HTML tables.

PDEQ creates data graphs using a package of Java applets, Object Planets' Line Charting application. PDEQ staff wrote routines using this application to display air quality information on the Web site.

For the telephone hotline, PDEQ purchased Envview2000 software from Envitech and their U.S. affiliate, DR DAS. This software uses the data from MS Access and stores the data in a SQL Server 7 database. PDEQ staff recorded the "voices of air quality" in English and Spanish for use on the hotline.

### **DATA VISUALIZATION TOOLS**

The ozone air pollution maps shown on the Air Info Now Web site are based on near real-time measurements of ground-level ozone in the Tucson metropolitan area. Several ozone monitors within the Tucson metropolitan area provide continuous measurements of hourly averaged ground-level ozone. The program then promptly transfers the hourly averages to a central computer hub where the ground-level ozone maps are generated.

With only eight ozone monitors to work with, the Air Info Now Program team developed a regression-based spatial modeling approach to map ozone levels in the region. The geography of Tucson allows the model to estimate ozone concentrations at locations where measurements are not taken regularly. The model relates near real-time ozone measurements to the local geography of the monitors in Tucson's monitoring network. The program team used several years (1995–1998) of hourly averaged ozone data to "train" the model and to develop statistical relationships between local geography and measured ozone concentrations. The model provides a continuous surface map of estimated ground-level ozone concentrations across the Tucson metropolitan area.

### **OUTREACH BARRIERS AND STRATEGIES**

As with any environmental monitoring program, successful communication with the community is key to achieving the program goals. The Air Info Now program's outreach activities include the development and operation of its Air Info Now Web site (<http://www.airinfnow.org/>). Because the Tucson community includes English- and Spanish-speaking residents, the Web site can be viewed in either English or Spanish. The Web site provides air quality information to the community, including the Air Quality Index for ozone, carbon monoxide, and particulate matter and a ground-level ozone map for the area. The public can use these data to plan their daily activities.

The Web site includes tools to educate the public about air pollution. The "Activities" page, for example, includes:

- Online games to teach users about ozone and carbon monoxide, and the effect air pollutants have on your lungs.
- Experiments to teach users about particulate matter, smog, and greenhouse gases.
- List of 50 things you can do to reduce air pollution.

The Web site also includes air pollution information specifically geared toward teachers for incorporation into lesson plans for various age groups and details on the health effects of ozone, carbon monoxide, and particulate matter.

In addition to the Web site, the Air Info Now Program operates a hotline for accessing regional air quality information. The hotline number is 520-882-4AIR.

To inform the community about the Web site and hotline, the Air Info Now Program performed an extensive public and media outreach process to educate the targeted audience about these tools. PDEQ staff developed promotional literature and artwork for the following outreach tools:

- The Air Info Now logo.
- Fact sheets (for the media, educators, and healthcare providers).
- Bookmarks (in English and Spanish).
- Flingers.
- Pens.
- Mirage boards.
- Magnets.

The Air Info Now partners provided information about the availability of these new air pollution resources to a variety of groups in the targeted audience, including teachers, students, local health department staff, school nurses, home health care practitioners, pharmacists, physicians, and the media. In addition, the Web site was linked to several relevant Web sites to increase the number of visits to the site.

#### **FOR MORE INFORMATION**

E-mail the Pima County Department of Environmental Quality at [webmail@deq.co.pima.az.us](mailto:webmail@deq.co.pima.az.us).

## CASE STUDY: AIRBEAT PROJECT OF ROXBURY, MASSACHUSETTS

### ABOUT THE PROJECT

Over the past 15 years, an epidemic of asthma has been occurring in the United States. American children in particular have been severely affected. EPA's Office of Children's Health Protection estimates that 4.8 million children under 18 years of age—one out of every 15 children—have asthma. Asthma rates have increased 160 percent in the past 15 years in children under 5 years of age.

The problem is even worse among some inner-city populations. In certain neighborhoods of New York City, for example, one out of every five children has asthma. In Roxbury, an urban neighborhood in the heart of Boston, the asthma hospitalization rate is annually among the highest in Massachusetts (in 1992 it was five times the state average). Although Americans of all ages, races, and ethnic groups have been affected by asthma, nationwide data show that the epidemic is most severe among lower-income and minority children.

These data have led to heightened concern about the quality of air that inner-city children are breathing—both indoors and out. In recent years, scientists have developed a better understanding of the role that air pollutants can play in exacerbating asthma symptoms and triggering asthma attacks. Much work has been done to reduce children's exposures to indoor air pollutants and allergens such as cigarette smoke, cockroach particles, dust mites, and animal hair, because these are considered among the most common asthma triggers. At the same time, there is growing recognition of a need for better information on children's exposures to outdoor air pollutants.

Throughout most of the United States, levels of outdoor air pollutants are much lower today than they were in the past. However, in some parts of the country (particularly urban areas), outdoor air is getting worse, not better. Pollutants of concern include ground-level ozone (formed by the chemical reaction of pollutants in emissions from vehicles, power plants, and other sources) and particulate matter (dust, dirt, soot, smoke, and liquid droplets emitted into the air by sources such as cars, trucks, buses, factories, and construction activities). Both of these pollutants have been linked to asthma and other respiratory illnesses, and both tend to be in the highest concentration in urban areas.

To protect their health, inner-city residents need timely access to air quality data. Levels of outdoor air pollutants such as ground-level ozone and particulate matter vary from day to day and even during the course of a single day. Access to air quality forecasts and real-time data allow residents to reduce their exposures when pollutant levels are high. For children and others with asthma, reducing exposures to asthma triggers can be part of a multi-faceted approach to managing symptoms that also includes behavior changes, drug therapy, and frequent medical follow-ups. Patient education is also key to this approach.

In 1999, a team of academic, community, and government organizations launched a pilot project to collect and communicate real-time data on air pollution in Roxbury, Massachusetts. This pilot project, which became known as AirBeat, was funded with a grant from EPA's EMPACT Program. The AirBeat Project had two main goals: 1) to collect near real-time ambient air quality data for ground-level ozone, particulate matter (PM<sub>2.5</sub>), and other pollutants, and to develop data techniques for managing those data and 2) to communicate near real-time air quality data to the public in a way that can be easily understood and used by community residents to reduce human exposure.

## PARTNER ORGANIZATIONS

Roxbury, Massachusetts, was chosen as the site for the pilot program for three reasons:

- Historically, Roxbury has documented high rates of asthma and other respiratory illnesses, raising widespread concern about the local air quality.
- Diesel-powered vehicles have been shown to be major contributors to  $PM_{2.5}$  emissions, and there are more than 15 bus and truck depots housing more than 1,150 diesel-powered vehicles within the Dudley Square area of Roxbury.
- Roxbury is home to a number of strong community organizations that have been working for years on a variety of environmental health and justice issues.

Local organizations involved in the AirBeat Project include the Suffolk County Conservation District, Alternatives for Community and Environment, Harvard School of Public Health, the Massachusetts Department of Environmental Protection (MA DEP), and Northeast States of Coordinated Air Management.

## COLLECTING AND MANAGING THE DATA

AirBeat's near real-time pollution data come from a single monitoring station located in Dudley Square, a major commercial hub in the center of Roxbury. This monitoring station is part of a statewide network of 42 monitoring sites operated by MA DEP to gather data on ambient air concentrations of criteria pollutants.

In 1997, MA DEP began investigating the possibility of siting a  $PM_{2.5}$  monitor in Roxbury to comply with new  $PM_{2.5}$  monitoring requirements set by EPA earlier that year. In siting the monitor, MA DEP invited the input of several local community organizations, including Alternatives for Community and Environment, an environmental justice organization that advocated the need for air quality monitoring in Roxbury. Together, they agreed on the Dudley Square location. Out of this cooperative effort, the AirBeat project was born. The driving motivation behind the project was a desire to leverage the air quality information from the new monitoring site by making the data accessible to Roxbury residents in real time. The project partners also hoped to use the air quality data to address community concerns that elevated concentrations of certain air pollutants, such as ozone and particulate matter, might be contributing to Roxbury's high asthma hospitalization rate and the incidence of other respiratory illnesses.

To address these concerns, the AirBeat team arranged to include the following monitoring capabilities at the Dudley Square site:

- Continuous monitoring for  $PM_{2.5}$ .
- Continuous monitoring for black carbon soot (BC), which is a strong indicator of diesel emissions. Although BC is a component of  $PM_{2.5}$  (typically about 10 percent by mass), its temporal variation can be very different—BC concentrations often peak during morning rush hour.
- Continuous monitoring for ozone.
- Meteorological monitoring to track weather conditions.

The AirBeat team also made arrangements with MA DEP to download the raw monitoring data directly from the Dudley Square station via a modem-to-modem connection, so that AirBeat could process the data and deliver it to the public in real time.

The AirBeat project uses two innovative methods for air pollution monitoring, both ideal for highly urbanized centers with large diesel fuel emissions. The first of these, the Continuous Ambient Mass Monitor, is a new tool for measuring PM<sub>2.5</sub> concentrations in ambient air. The AirBeat team also tested an innovative method for monitoring BC concentrations: the Aethalometer, which provides a surrogate measurement of diesel emissions. Both of these methods have proved reliable.

#### **DATA VISUALIZATION TOOLS**

The ozone air pollution maps shown on the AirBeat Web site are based on near real-time measurements of ground-level ozone in the northeastern United States. The map uses color codes to display the recent ozone levels.

#### **OUTREACH STRATEGIES**

The AirBeat team planned an extensive outreach program to communicate the air quality monitoring results in an understandable manner to local citizens and to educate them about the connections between air pollution and health effects.

Starting in 2000, the AirBeat team began presenting the data collected by the ambient air quality monitoring station in near real-time for public access on the AirBeat Web site (<http://www.airbeat.org/>) and via a telephone hotline system.

#### **FOR MORE INFORMATION**

Consult the following resources for more information about the AirBeat Project:

- Alternatives for Community and Environment  
<http://www.ace-ej.org/>
- Massachusetts Department of Environmental Protection  
<http://www.state.ma.us/dep/dephome.htm>
- Northeast States for Coordinated Air Use Management  
<http://www.nescaum.org>

#### **CONTACTS FOR THE AIRBEAT PROJECT**

*George Allen*

Northeast States for Coordinated Air Use Management

Phone: 617-367-8540

E-mail: [gallen@nescaum.org](mailto:gallen@nescaum.org)

*Jodi Sugerman-Brozan*

Alternatives for Community and Environment

Phone: 617-442-3343 x23

E-mail: [jodi@ace-ej.org](mailto:jodi@ace-ej.org)

*Matthew Goode*

Suffolk County Conservation District

Phone: 617-451-9141

*Jerry Sheehan*

Massachusetts Department of Environmental Protection

Phone: 617-292-5500

E-mail: [jerry.sheehan@state.ma.us](mailto:jerry.sheehan@state.ma.us)



## APPENDIX B

### LIST OF USEFUL WEB SITES AND REFERENCES

#### ENVIRONMENTAL MONITORING PROJECT WEB SITES

- Office of Research and Development Technology Transfer Web Site: <http://www.epa.gov/ttbnrmrl>—provides information on EMPACT projects, environmental topics (e.g., air, drinking water, watersheds), and pollution prevention.
- Paso del Norte Environmental Monitoring Project Web Site: <http://www.ozonemap.org>—provides information on air quality, traffic and transit, and weather for the El Paso, Texas, metropolitan and surrounding area.
- Air Info Now Environmental Monitoring Project Web Site: <http://www.airinfnow.org>—provides information about air quality, health concerns related to air pollution, and local solutions to improve air quality in the Tucson, Arizona, area.

#### AIR QUALITY MONITORING RESOURCES

- EPA's *Ozone Monitoring, Mapping, and Public Outreach* (EPA/625/R-99/007) document helps users identify monitoring locations and equipment for ground-level ozone. Available online at: <http://www.epa.gov/airnow/cdmanual.pdf>.
- Clean Air Act information: <http://www.epa.gov/epahome/laws.htm>—includes the full Clean Air Act law and a plain English Guide to the Act.
- Office of Air and Radiation's Technology Transfer Network: <http://www.epa.gov/ttn/amtic>—provides links to information on air quality monitoring, including methods and standards.
- EPA's AirNow Web Site: <http://www.epa.gov/airnow/>—lists information on the Air Quality Index.

#### TRAFFIC MONITORING RESOURCES

- Federal Highway Administration: <http://www.fhwa.dot.gov/>—search this Web site for additional information on traffic monitoring and transit planning.
- The Federal Highway Administration's *A Summary of Vehicle Detection and Surveillance Technologies Used in Intelligent Transportation Systems* document describes the various traffic monitoring equipment and applications. Available online at: <http://www.fhwa.dot.gov/ohim/tvtw/vdstits.htm>.
- U.S. Department of Transportation's Travel Model Improvement Program: <http://tmip.tamu.edu/>—provides information on traffic monitoring, transit modeling, and data collection.

#### QUALITY CONTROL RESOURCES

- EPA's *Guidance for the Preparation of Standard Operating Procedures (SOPs) for Quality-Related Documents* (EPA/600/R-96/027) helps users develop standard operating procedures. Available online by searching the EPA Web site by publication number (<http://www.epa.gov/clhtml/pubtitle.html>).
- The EPA Ambient Monitoring Technology Information Center's quality assurance/quality control page: <http://www.epa.gov/ttn/amtic/qaqc.html>.

#### COMPUTER MODELS

- EPA's Office of Transportation and Air Quality Web site: <http://www.epa.gov/otaq/>—provides details on the vehicle exhaust emissions model MOBILE 6 (most recent version).



United States  
Environmental Protection  
Agency

Office of Research and  
Development  
National Risk Management  
Research Laboratory  
Cincinnati, OH 45268

Official Business  
Penalty for Private Use  
\$300

EPA/625/R-02/013  
February 2003

Please make all necessary changes on the below label,  
detach or copy, and return to the address in the upper  
left-hand corner.

If you do not wish to receive these reports CHECK HERE ;  
detach, or copy this cover, and return to the address in the  
upper left-hand corner.

PRESORTED STANDARD  
POSTAGE & FEES PAID  
EPA  
PERMIT No. G-35