

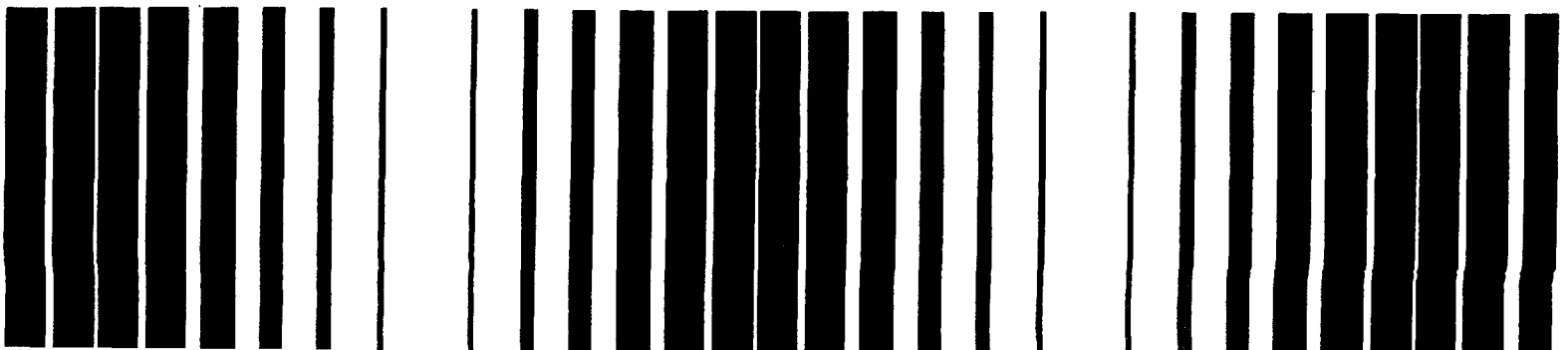

# Guide to Cleaner Technologies

## Organic Coating Removal



**GUIDE TO  
CLEANER TECHNOLOGIES**

**ORGANIC COATING REMOVAL**

Office of Research and Development  
United States Environmental Protection Agency  
Cincinnati, Ohio 45268



*Printed on Recycled Paper*

---

## NOTICE

This material has been funded wholly or in part by the United States Environmental Protection Agency under Contract No. 68-C0-0003, Work Assignment 3-49, to Battelle. Mention of trade names or commercial products does not constitute endorsement or recommendation for use.

This *Guide to Cleaner Technologies: Organic Coating Removal* has been subjected to U.S. Environmental Protection Agency peer review and administrative review and approved for publication. Approval does not signify that the contents necessarily reflect the views and policies of the U.S. Environmental Protection Agency.

This document identifies new approaches for pollution prevention in paint removal. Site-specific selection of a technology will vary depending on shop and manufacturing process applications. It is the responsibility of individual users to make the appropriate application of these technologies. Compliance with environmental and occupational safety and health laws is the responsibility of each individual business and is not the focus of this document.

---

## FOREWORD

Today's rapidly developing and changing technologies and industrial products and practices frequently carry with them the increased generation of materials that, if improperly dealt with, can threaten both public health and the environment. The U.S. Environmental Protection Agency (EPA) is charged by Congress with protecting the nation's land, air, and water resources. Under a mandate of national environmental laws, the agency strives to formulate and implement actions leading to a compatible balance between human activities and the ability of natural systems to support and nurture life. These laws direct the U.S. EPA to perform research to define our environmental problems, measure the impacts, and search for solutions.

Reducing the utilization or generation of hazardous materials at the source or recycling the wastes on site is one of EPA's primary pollution prevention goals. Economic benefits to industry may also be realized by reducing disposal costs and lowering the liabilities associated with hazardous waste disposal.

The series, Guides to Cleaner Technologies, summarizes information collected from U.S. Environmental Protection Agency programs, peer-reviewed journals, industry experts, vendor data, and other sources. The cleaner technologies are categorized as commercially available or emerging. Emerging technologies are technologies that are in various stages of development and are not immediately available for purchase and installation. For each technology, the Guide addresses its pollution prevention benefits, operating features, application, and limitations.

---

## ACKNOWLEDGMENTS

This *Guide* was prepared under the direction and coordination of Douglas Williams of the Center for Environmental Research Information (CERI) and Paul Randall of the Risk Reduction Engineering Laboratory (RREL) of the U.S. Environmental Protection Agency (EPA), Cincinnati, Ohio. Battelle compiled and prepared the information used for this *Guide*.

The following people provided significant assistance in reviewing the *Guide* and making suggestions: Ron Joseph, Ron Joseph & Associates, Inc., Saratoga, California; David Thomas, Hazardous Waste Research and Information Center, Champaign, Illinois; Thomas F. Stanczyk, Recra Environmental Inc., Amherst, New York; and Charles Darwin, U.S. EPA, Organics Control Branch, Research Triangle Park, North Carolina.

---

## CONTENTS

Notice .....	ii
Foreword .....	iii
Acknowledgments .....	iv
Section 1. Overview .....	1
What is Cleaner Technology? .....	1
Coating Removal Applications .....	1
Pollution Problem .....	1
Solution .....	3
What's In This Guide? .....	4
Other Questions Affecting Investment Decisions .....	4
Who Should Use This Guide? .....	4
Keywords .....	5
References .....	5
Section 2. Available Technologies .....	6
How To Use the Summary Tables .....	6
Plastic Media Blasting .....	12
Wheat Starch Blasting .....	16
Burnoff Coating Removal .....	18
Molten Salt Coating Removal .....	20
Sodium Bicarbonate Wet Blasting .....	22
Carbon Dioxide Pellet Cryogenic Blasting .....	25
High-Pressure Water Blasting .....	30
Medium-Pressure Water Blasting .....	31
Liquid Nitrogen Cryogenic Blasting .....	32
Section 3. Emerging Technologies .....	36
How To Use the Summary Tables .....	36
Laser Heating .....	38
Flashlamp Heating .....	39
Ice Crystal Blasting .....	39
Section 4. Pollution Prevention Strategy .....	41
Section 5. Cleaner Technology Transfer Considerations .....	43
Introduction .....	43
Coating Properties .....	44
Part and Substrate Properties .....	44
Process Concerns .....	44
References .....	45
Section 6. Information Sources .....	46

---

## FIGURES

Figure 1.	Sodium bicarbonate system with wet blast head. ....	23
Figure 2.	Flow diagram of sodium bicarbonate wet blast system. ....	24
Figure 3.	A typical liquid CO <sub>2</sub> blast system. ....	28
Figure 4.	Operation of cryogenic coating removal process equipment. ....	34

## TABLES

Table 1.	Available Cleaner Technologies for Coating Removal: Descriptive Aspects .....	7
Table 2.	Available Cleaner Technologies for Coating Removal: Operational Aspects .....	10
Table 3.	Emerging Cleaner Technologies for Coating Removal: Descriptive Aspects .....	37
Table 4.	Emerging Cleaner Technologies for Coating Removal: Operational Aspects .....	37
Table 5.	Health, Physical, and Chemical Data for Methylene Chloride .....	42
Table 6.	Trade Associations and Technology Areas .....	46

---

## SECTION 1 OVERVIEW

### What Is Cleaner Technology?

A *cleaner technology* is a source reduction or recycle method applied to eliminate or significantly reduce hazardous waste generation. *Source reduction* includes product changes and source control. *Source control* can be further characterized as input material changes, technology changes, or improved operating practices.

Pollution prevention should emphasize source reduction technologies over recycling but, if source reduction technologies are not available, recycling is a good approach to reducing waste generation. Therefore, recycling should be used where possible to minimize or avoid waste treatment requirements when source reduction options have been evaluated and/or implemented.

The cleaner technology must, of course, reduce the quantity, toxicity, or both of the waste produced. It is also essential that the final product quality be reliably controlled to acceptable standards. In addition, the cost of applying the new technology relative to the cost of similar technologies needs to be considered.

### Coating Removal Applications

Paint and other coatings are applied to surfaces to enhance corrosion resistance, improve appearance, or both. Often the coatings need to be removed either as part of the manufacturing operation or, later in the life of the equipment, to enable maintenance or repair.

Examples among the many industries that need to remove organic coatings include builders and maintainers of

- Automobiles
- Aircraft
- Appliances
- Defense material
- Shipbuilding
- Wood products.

These examples indicate some of cross-industry applications for cleaner coating removal technologies.

Coating removal frequently is required as part of rework operations on the production line. Even in the best of operations, some parts will be improperly covered. For all but the simplest and cheapest items, stripping the defective coating and refinishing is more economical than disposing of the poorly finished item.

Production line equipment also must be cleaned on a routine basis. Racks, hangers, load bars, or spray booth grates support parts during painting. The supports and other components in the painting line become covered with overspray. A heavy buildup of paint interferes with proper support of the product or can flake off and contaminate the work surface. Even thin buildup of paint residue reduces electrostatic grounding, increases material loss, or increases the need for touch-up painting. Therefore, excess paint must be removed from supports and other paint line components.

The need for paint removal also occurs later in equipment life as the paint becomes soiled, worn, or damaged with use. Touch-up or complete recovering can renew the function of the paint for a few cycles, but buildup eventually requires removing the old paint. Also, particularly in the aircraft industry, a paint must be removed to allow inspection of the underlying part.

### Pollution Problem

Solvent strippers have been widely used for industrial coating removal for many years. Solvent strippers can be applied at room temperature to remove a wide range of organic coatings without attacking metal substrates. Solvent strippers consist mainly of methylene chloride which typically constitutes 60% to 65% of the formulation. Other ingredients such as activators, corrosion inhibitors, thickeners, and evaporation retarders are used to supplement the methylene chloride to improve coating removal performance. Neutral solvent strippers typically supplement methy-



lene chloride with cresylic acid, methanol, and monoethanolamine. Acidic solvent strippers typically include phenol, formic acid, and methanol monoethanolamine in the formulation in addition to the methylene chloride. Other additives may include toluene, sodium chromate, ammonia, bentonite, metallic soaps, polyacrylate, esters, cellulose acetate, ethyl cellulose, and waxes (Operowsky, 1993).

Activators include methanol, acids, alkalies, and amines, which increase the rate of paint removal. For example, formic and acetic acids remove epoxy resins by hydrolyzing their ether linkages. Corrosion inhibitors, such as propylene oxide and butylene oxide, scavenge free acids such as HCl, which can form due to decomposition of methylene for wipe-on application methods and also may impart desirable characteristics for immersion stripping systems. Most thickeners are based on alkyl cellulose and work by forming hydrophilic colloids. Evaporation retarders, such as paraffin wax, are used to reduce vapor losses of volatile solvents such as methylene chloride.

paint removal/stripper	31%
plastics	16%
polyurethane foam	14%
pharmaceuticals	11%
metal cleaning/degreasing	11%
aerosols	8%
electronics	4%
miscellaneous (pesticides, food processing, synthetic fibers)	5%

Methylene chloride removes the coating mainly by causing it to swell and then lift off the substrate. Because of the small size of the molecule, methylene chloride penetrates beneath the coating surface to the substrate and causes the film to swell and thereby lifts it off the substrate. The intermediate solvency of methylene chloride prevents the coating from being dissolved and redeposited. These properties produce a characteristic wrinkling, bubbling, and blistering action, which signifies that the film is ready for scraping or flushing.

The solvent stripping chemical is wiped or spread onto the coated substrate. The softened coating and solvent sludge are then wiped, scraped, or flushed off. In many applications, several repetitions are needed to give satisfactory coating removal. A water rinse often is used for final cleaning of the part.

**Chemicals in current solvent strippers trigger many regulatory and reporting requirements.**

Use of solvent strippers generates organic vapors, sludge containing solvents and metals, and wastewater containing solvents and metals. A wide range of environmental concerns about these environmental release paths are leading industries to seek cleaner alternatives to coating removal. Both federal and state programs are moving toward significant reduction of release of volatile organic compounds (VOCs), particularly hazardous air pollutants (HAPs). Examples of some of the major federal environmental regulations favoring reduction of VOCs include the Clean Air Act Amendments (CAAA), the Resource Conservation and Recovery Act (RCRA), the Right to Know provisions of the Superfund Amendment and Reauthorization Act (SARA), and the Pollution Prevention Act with its emphasis on eliminating pollution at the source. Reducing use of solvent strippers is also driven by increasing concerns for potential workplace health hazards due to VOCs.

**The Clean Air Act Amendments impose limitations on 189 hazardous air pollutants.**

Title III of the CAAA is a comprehensive plan for reducing emissions of hazardous air pollutants. An initial list of 189 HAPs is given in the CAAA; other HAPs may be added to the list. The EPA has, in accordance with the CAAA, identified major source categories for HAPs and is now defining Maximum Achievable Control Technology (MACT) standards for source categories. Paint stripper use is identified as one of the source categories requiring MACT standards (57 FR 31592, July 16, 1992). A number of coating operations also are identified in the initial list of categories of major and area sources of hazardous air pollutants (57 FR 31591, July 16, 1992). Since paint removal may be required as part of the rework process, paint removal MACT standards for paint stripping may be developed for some of the coating industries as well.

Solvent waste disposal procedures and requirements of the RCRA increase waste management costs, establish cradle-to-grave responsibility for wastes, and require the waste generator to maintain a waste minimization program.

Section 313 of Title III of the Superfund Amendments and Reauthorization Act (SARA) establishes toxic chemical release reporting requirements. Facilities with Standard Industrial Classification (SIC) Codes in the range of 20-39, meeting company size and chemical quantity thresholds, must report discharge and recy-

cling of toxic chemicals. The common stripping solvents such as methylene chloride, phenol, and methanol are among the more than 300 chemicals covered by the toxic chemical reporting requirements.

In addition to the RCRA requirement for a waste minimization program for all hazardous waste generators, the Pollution Prevention Act of 1990 establishes a priority on reducing use of hazardous materials. Of specific interest to organic coating removal, methylene chloride is one of the 17 priority toxic chemicals identified for voluntary reduction by the 33/50 Program (U.S. EPA, 1991; 1992).

*Organic solvents cause worker health concerns.*

The organic solvents in cold solvent stripper formulations result in sufficient vapor concentrations to cause concern for workers in the area. In particular methylene chloride has been identified by the National Institute for Occupational Safety and Health (NIOSH) as a chemical that should be treated as an occupational carcinogen. NIOSH recommends that occupational exposure to carcinogens be limited to the lowest feasible concentration. Of course, complete elimination of methylene chloride gives the lowest reduction. If carcinogens must be used, NIOSH recommends that only the most reliable and protective respirators be used to ensure maximum protection.

*Coating residue alone may be hazardous.*

The removed coating materials may also cause environmental concerns. Some pigments contain toxic metals such as cadmium, lead, and chromate. The removed coating debris may also contain unreacted resins which can cause problems for the environment or worker safety. Waste generation from lead paint abatement is an area of particular concern due to the toxicity of lead and the large surface area currently coated with lead-containing paints. Most lead paint removal is done by abrasive blasting and thus is not covered specifically by this guide. However, the technologies discussed in this guide can be applied to minimize waste generation in lead paint abatement. Other techniques such as abrasive media recycling, which apply specifically to abrasive blasting waste minimization, are not discussed in this guide but should be explored for lead paint abatement waste minimization.

## Solution

The solution to pollution from paint removal operations that should be explored first is to not paint the part and thus avoid the need to strip it. Some airlines have tried polished aluminum skins and report that the appear-

ance is acceptable and the life-cycle cost is lower than painting with periodic removal to allow inspections (Boeing, 1993). However, for most applications, the coating improves appearance or performance or both and must still be used.

*When possible, eliminate pollution at the source.*

Cleaner technologies based on physical coating removal are commercially available or are being developed to replace solvents strippers. Physical coating removal technologies take advantage of differences in physical properties between the coating and the substrate to destroy the bonding and/or abrade the coating from the underlying substrate. Protecting the underlying substrate from damage while achieving good coating removal is a major concern.

*Cleaner coating removal technologies are developing rapidly to fill a variety of process needs.*

Cleaner coating removal technologies use one or more of four general types of physical mechanisms:

- **Abrasive technologies** wear the coating off with scouring action.
- **Impact technologies** rely on particle impact to crack the coating to remove it.
- **Cryogenic technologies** use extreme cold to make the coating more friable and induce differential contraction to debond the coating.
- **Thermal technologies** use heat input to oxidize, pyrolyze, and/or vaporize the coating.

Many cleaner organic coating removal applications combine these methods. The abrasion and impact mechanisms typically occur together in technologies emphasizing one mechanism over the other. For example, sodium bicarbonate stripping relies mainly on abrasion with some removal by impact. On the other hand, plastic media blasting (PMB) relies mainly on impact to crack and remove the coating but includes some abrasive action. The cryogenic technologies use a coolant, such as liquid nitrogen, to provide a cooling mechanism supplemented with PMB or other technology using an impact removal mechanism. Thermal technologies burn the organic coating to form an ash but often are followed by ash or soot removal with a technology providing an impact mechanism.

No one coating removal technology will replace solvent strippers in all applications. Alternative methods are available for effective, safe coating removal in specific

---

applications. The important factors in reviewing the applicability of a technology are discussed in Cleaner Technology Transfer Considerations (Section 5).

## What's In This Guide?

This application guide describes cleaner technologies that can be used to reduce waste in coating removal operations. The objectives of this application guide are to help identify potentially viable cleaner technologies to reduce waste by using alternative organic coating removal methods and to provide resources for obtaining more detailed engineering information about the technologies. We address the following specific questions:

- What alternative coating technologies are available or emerging that could significantly reduce or eliminate pollution being released from current operations?
- Under what circumstances might one or more of these alternative coating systems be applicable to your operations?
- What pollution prevention, operating, and cost benefits could be realized by adapting the technology?

## Other Questions Affecting Investment Decisions

Other aspects affecting the decision to explore one or more cleaner technologies include

- Might new pollution problems arise when implementing cleaner technologies?
- Are tighter and more complex process controls needed?
- Will product quality and operating rates be affected?
- Will new operating or maintenance skills be needed?
- What are the overall capital and operating cost implications?

Whenever possible, these questions are answered in this guide. The cleaner coating removal systems described in this guide are applicable under different sets of product and operating conditions. If one or more are sufficiently attractive for your operations, the next step would be to contact vendors or users of the technology to obtain detailed engineering data and make an in-depth evaluation of its potential for your plant.

## Who Should Use This Guide?

*Plant-specific factors must be considered in selecting a cleaner technology*

This guide to cleaner technology has been prepared for plant process and system design engineers, and for personnel responsible for process improvement and process design. Plant-specific factors that must be considered in the selection of cleaner candidates to replace solvent stripper include (Dotson and Ballard, 1992):

- Characteristics of the part such as size, substrate hardness, and heat tolerance
- Paint or coating composition
- Desired substrate texture after stripping (rough or smooth)
- Stripping rate and production volume throughput needed
- Space available
- Compatibility with existing plant systems
- Types of wastes produced
- Capital and operating cost.

Process descriptions within this guide allow engineers to evaluate options so that cleaner technologies can be considered for existing plants and factored into the design of new coating removal operations.

Pollution Prevention Strategy, Section 4, discusses the impact of regulations on the potential for cleaner technologies. The Cleaner Technology Transfer Considerations, Section 5, discusses the various technical, economic, and regulatory factors that influence the selection and use of a cleaner technology.

Sufficient information is presented to select one or more candidate technologies for further analysis and in-plant testing. This guide does not recommend any technology over any other. It presents concise summaries of applications and operating information to support preliminary selection of cleaner technology candidates for testing in specific processes. Sufficient detail is provided to allow identification of possible technologies for immediate application to eliminate or reduce waste production.

The cleaner technologies described in this guide are divided into two groups based on their developmental maturity: available technologies and emerging technologies in advanced pilot plant testing. A list of keywords is provided to help you quickly scan the available technologies covered.

---

## Keywords

Cleaner Technology  
Pollution Prevention  
Recycling  
Source Reduction  
Source Control  
Blasting  
Coating Removal  
Debonding  
Depainting  
Paint Stripping  
Plastic Media  
Wheat Starch  
Burnoff  
Molten Salt

Sodium Bicarbonate  
Carbon Dioxide Pellets  
High-Pressure Water  
Medium-Pressure  
Water  
Liquid Nitrogen  
Cryogenic Coating  
Removal  
Laser  
Flashlamp  
Ice Crystal  
Pyrolysis  
Thermal

## References

Boeing. 1993. "Paint Stripping." *Structure Conference*. SE-ACM-3-1-93, Boeing Commercial Airplane Group, Section 10, Service Engineering, Seattle, Washington.

Dotson, R., and R. Ballard. 1992. "A Safe and Cost-Efficient Method of Stripping Rejected Parts." *Metal Finishing*, 90(4):29-32.

Operowsky, R. M. 1993. "Chemical Immersion Paint Stripping." In: *Metal Finishing — Organic Finishing Guidebook and Directory*, Elsevier Publishing, New York, New York.

U.S. Environmental Protection Agency. 1991. *The 33/50 Program: Forging an Alliance for Pollution Prevention* (2nd ed.). Special Projects Office, Office of Toxic Substances, Washington, D.C. July.

U.S. Environmental Protection Agency. 1992. *EPA's 33/50 Program Second Progress Report*. TS-792A, Office of Pollution Prevention and Toxics, Washington, D.C.

---

## SECTION 2 AVAILABLE TECHNOLOGIES

### How To Use the Summary Tables

Nine available cleaner coating removal technologies are evaluated in this section, namely

- Plastic media blasting
- Wheat starch blasting
- Burnoff coating removal
- Molten salt coating removal
- Sodium bicarbonate wet blasting
- Carbon dioxide pellet cryogenic blasting
- High-pressure water blasting
- Medium-pressure water blasting
- Liquid nitrogen cryogenic blasting.

Tables 1 and 2 summarize descriptive and operational aspects of these technologies. Readers are invited to refer to the summary tables throughout this discussion to compare and contrast technologies.

#### Descriptive Aspects

Table 1 shows the main **Coating Removal Mechanism(s)** of each available technology. It next lists the **Pollution Prevention Benefits, Reported Application, Benefits, and Limitations** of each available cleaner technology.

#### Operational Aspects

Table 2 shows the key operating characteristics for the available technologies. These tables give users a compact indication of the range of technologies covered to allow preliminary identification of technologies that may be applicable to specific situations. Tables 1 and 2 contain evaluations or annotations describing each available cleaner technology.

In Table 2, **Process Complexity** is qualitatively ranked as "high," "medium," or "low" based on such factors as the number of process steps involved and the number of material transfers needed. **Process Complexity** is an indication of how easily the new technology can be integrated into existing plant operations. A large

number of process steps or input chemicals, or multiple operations with complex sequencing, are examples of characteristics that would lead to a high complexity rating.

*The summary tables will help identify possible candidate cleaner technologies*

The **Required Skill Level** of equipment operators also is ranked as "high," "medium," or "low." **Required Skill Level** is an indication of the level of sophistication and training required by staff to operate the new technology. A technology that requires the operator to adjust critical parameters would be rated as having a high skill requirement. In some cases, the operator may be insulated from the process by complex control equipment. In such cases, the operator skill level is low but the maintenance skill level is high.

*Use the information in the text, from the references, and from industry and trade groups to get more detail on the best candidates.*

Table 2 also lists the **Waste Products and Emissions** from the available cleaner technologies to indicate tradeoffs in potential pollutants, the waste reduction potential of each, and compatibility with existing waste recycling or treatment operations at the plant. The **Capital Cost and Energy Use** columns provide a preliminary measure of process economics. The **Capital Cost** is a qualitative estimate of the initial cost impact of the engineering, procurement, and installation of the process and support equipment compared to current coating removal equipment.

Due to the diversity of cost data and the wide variation in plant needs and conditions, it is not possible to give specific cost comparisons. Cost analysis must be plant-specific to adequately address factors such as the type and age of existing equipment, space availability, throughput, product type, customer specifications, and cost of capital. Where possible, sources of cost data

**Table 1. Available Cleaner Technologies for Coating Removal: Descriptive Aspects**

Technology/ Coating Removal Mechanism	Pollution Prevention Benefits	Reported Application	Benefits	Limitations
Plastic Media Blasting  Impact/ Abrasive	<ul style="list-style-type: none"> <li>Eliminates VOCs and HAPs</li> <li>Uses nontoxic media</li> <li>Uses a dry process</li> <li>Spent media are cleaned and reused several times for paint stripping</li> <li>Some spent thermoplastic media are recyclable to make plastic products</li> </ul>	<ul style="list-style-type: none"> <li>Removes paint from a variety of metal and non-metal substrates</li> <li>Strips aircraft components and ground support equipment</li> <li>Cleans/strips commercial and industrial parts</li> <li>Removes powder coatings from sensitive substrates</li> </ul>	<ul style="list-style-type: none"> <li>Provides high-throughput-controlled coating removal</li> <li>Can selectively remove individual coating layers</li> <li>Eliminates water use</li> <li>When stripping is done with thermoplastic media, the waste may be recyclable</li> </ul>	<ul style="list-style-type: none"> <li>Spent plastic media contain paint chips and so may be hazardous waste</li> <li>Requires workers to wear respiratory and eye protection equipment</li> <li>Blasting generates high noise levels</li> <li>May cause metal substrate damage</li> <li>More aggressive media types damage fiberglass or composite materials</li> <li>Contaminants in media cause stress risers in the substrate</li> <li>Uses flammable media</li> </ul>
Wheat Starch Blasting  Impact/ Abrasive	<ul style="list-style-type: none"> <li>Eliminates VOCs and HAPs</li> <li>Spent media are cleaned and reused several times for paint stripping</li> <li>Uses a nontoxic, biodegradable medium</li> <li>Uses a dry process</li> </ul>	<ul style="list-style-type: none"> <li>Gentle stripping action suitable for abrasion sensitive fillers and composite materials</li> <li>Gaining acceptance for thin, soft aluminum in commercial aircraft skins</li> </ul>	<ul style="list-style-type: none"> <li>Provides controlled coating removal</li> <li>Can selectively remove individual coating layers</li> <li>Eliminates water use</li> <li>Uses inexpensive media</li> <li>Media are nontoxic and biodegradable</li> </ul>	<ul style="list-style-type: none"> <li>Spent starch media contain paint chips and so may be hazardous waste</li> <li>Dense contaminants in recycled media may damage substrate</li> <li>Stripping rate is generally slow to moderate</li> <li>Requires workers to wear respiratory and eye protection equipment</li> <li>Blasting generates high noise levels</li> <li>Media are moisture sensitive</li> </ul>
Burnoff Coating Removal  Thermal	<ul style="list-style-type: none"> <li>Eliminates VOCs and HAPs</li> </ul>	<ul style="list-style-type: none"> <li>Removes thick coatings from a variety of coating line fixtures and tools</li> </ul>	<ul style="list-style-type: none"> <li>Provides rapid removal of thick coatings</li> <li>Can process complex shapes</li> <li>Burnoff ovens can remove uncured coating</li> </ul>	<ul style="list-style-type: none"> <li>Generates coating ash residue that may be hazardous waste</li> <li>Will damage heat-sensitive materials such as heat-treated aluminum or magnets</li> <li>Coatings containing halogens (PVC or PTFE) and/or nitrogen will produce corrosive offgas</li> <li>Must not be used for low-melting metals or alloys</li> <li>Must not be used with pyrophoric metals</li> <li>May require offgas treatment, depending on local air permitting regulations</li> <li>Potential for generation of products of incomplete combustion</li> <li>Presents possibility of fire</li> </ul>
Molten Salt Coating Removal  Thermal	<ul style="list-style-type: none"> <li>Eliminates VOCs and HAPs</li> </ul>	<ul style="list-style-type: none"> <li>Removes thick coatings from a variety of coating line fixtures and tools</li> </ul>	<ul style="list-style-type: none"> <li>Provides rapid removal of thick coatings</li> <li>Can process complex shapes</li> <li>Salt bath ensures even heating</li> <li>Rinsewater waste is compatible with conventional water treatment systems</li> </ul>	<ul style="list-style-type: none"> <li>Generates by-product sludge that may be hazardous waste</li> <li>Will damage heat-sensitive materials such as heat-treated aluminum or magnets</li> <li>Must not be used for low-melting alloys</li> <li>Must not be used with pyrophoric metals</li> <li>May require offgas treatment, depending on local air permitting regulations</li> <li>Potential for generation of products of incomplete combustion</li> </ul>

(continued)

Table 1. (Continued)

Technology/ Coating Removal Mechanism	Pollution Prevention Benefits	Reported Application	Benefits	Limitations
Sodium Bicarbonate Wet Blasting  Abrasives/ Impact	<ul style="list-style-type: none"> <li>Eliminates VOCs and HAPs</li> <li>Uses nontoxic media</li> </ul>	<ul style="list-style-type: none"> <li>Removes paints from a variety of metal substrates</li> <li>Depaints wood without damaging the substrate</li> <li>Cleans and depaints brick walls</li> <li>Removes heavy accumulations of grease and dirt from mechanical equipment</li> </ul>	<ul style="list-style-type: none"> <li>Provides a controllable process for coating removal</li> <li>Can selectively remove individual coating layers</li> <li>Uses inexpensive stripping media</li> <li>In some cases, liquid waste may be discharged to a conventional wastewater treatment plant</li> <li>Use of water dissipates heat generated by the abrasion</li> <li>Eliminates need to prewash surface</li> <li>Sodium bicarbonate waste-streams are generally compatible with existing water treatment systems</li> </ul>	<ul style="list-style-type: none"> <li>Uses nonrecyclable stripping media</li> <li>Generates wet sodium bicarbonate sludge containing coating debris, which may be a hazardous waste</li> <li>System must be available to collect and treat wastewater containing sodium bicarbonate and paint chips</li> <li>May require exhaust ventilation system to control particulate</li> <li>Requires workers to wear respiratory and eye protection equipment</li> <li>Blasting generates high noise levels</li> <li>Media can be aggressive so potential for substrate damage exists</li> </ul>
Carbon Dioxide Pellet Cryogenic Blasting  Cryogenic/ Abrasives/ Impact	<ul style="list-style-type: none"> <li>Eliminates VOCs and HAPs</li> <li>Uses a dry process so no wastewater is generated</li> <li>Coating chips collected dry with no media</li> <li>Uses natural or industrial sources so no net production of carbon dioxide occurs</li> </ul>	<ul style="list-style-type: none"> <li>Strips surfaces needing high degree of final cleanliness</li> <li>Useful for equipment where it is desirable to avoid disassembly</li> <li>Useful when volume of residue must be minimized such as with radioactive-contaminated components or coatings containing hazardous metals (e.g., cadmium or lead)</li> </ul>	<ul style="list-style-type: none"> <li>Generates low volume of dry waste (none from the media)</li> <li>Eliminates water use</li> <li>Provides well-defined coating removal pattern</li> <li>Can selectively remove individual coating layers</li> <li>Requires limited pre- or poststripping cleanup</li> <li>No masking needed except for delicate materials such as soft clear plastics</li> <li>Equipment can be stripped without disassembly</li> <li>No media separation/recycling system needed</li> <li>No media disposal cost</li> <li>Pellets driven into interstitial spaces vaporize, leaving no residue</li> </ul>	<ul style="list-style-type: none"> <li>Generates small volume of coating debris, which may be a hazardous waste</li> <li>Requires ventilation to avoid potentially dangerous CO<sub>2</sub> concentrations</li> <li>Generates airborne particulates that may contain metal from the coatings</li> <li>Requires workers to wear respiratory and eye protection equipment</li> <li>Requires workers to wear hearing protection</li> <li>Possible worker exposure to extreme cold</li> <li>Potential for worker injury from high-velocity CO<sub>2</sub> pellet impact</li> <li>Rebounding pellets may carry coating debris and contaminate the work area or workers</li> <li>Nonautomated system fatigues workers quickly</li> <li>Possible static electricity buildup on substrate if no grounding provided</li> <li>Some coating debris may redeposit on substrate</li> <li>Low temperatures can cause condensation on substrate</li> <li>Large local temperature drops can occur in substrate but confined mainly to the surface layer</li> <li>May damage thermoset composite materials</li> <li>Difficult to control coating removal on graphite-epoxy composites</li> <li>Slow coating removal rate</li> <li>Equipment bulky and capital intensive</li> </ul>

(continued)

**Table 1. (Continued)**

Technology/ Coating Removal Mechanism	Pollution Prevention Benefits	Reported Application	Benefits	Limitations
High-Pressure Water Blasting  Impact	<ul style="list-style-type: none"> <li>Eliminates HAPs and VOCs</li> <li>Water can be processed and recycled during stripping, reducing wastewater volume</li> </ul>	<ul style="list-style-type: none"> <li>Robotic systems for rapid coating removal</li> </ul>	<ul style="list-style-type: none"> <li>High stripping rate</li> <li>Stripping water can be recycled</li> <li>Wastewater stream is compatible with existing water treatment systems</li> </ul>	<ul style="list-style-type: none"> <li>Coating debris sludge may be hazardous waste</li> <li>System is needed to collect and recycle stripping water</li> <li>Ultrahigh-pressure systems (&gt;15,000 psi) require expensive robotic operation</li> <li>Misapplied water jet will damage substrate</li> <li>Blasting generates high noise levels</li> <li>Water can enter cavities</li> <li>Water can penetrate and/or damage joints, seals, and bonded areas</li> </ul>
Medium-Pressure Water Blasting  Impact/may be supplemented with softening agents or abrasives	<ul style="list-style-type: none"> <li>Eliminates HAPs; some systems use VOCs containing softeners</li> <li>Water can be processed and recycled during stripping reducing wastewater volume</li> </ul>	<ul style="list-style-type: none"> <li>Rapid coating removal</li> </ul>	<ul style="list-style-type: none"> <li>High stripping rate</li> <li>Stripping water can be recycled</li> <li>Wastewater stream is compatible with existing water treatment systems</li> </ul>	<ul style="list-style-type: none"> <li>Coating debris sludge may be hazardous waste</li> <li>System is needed to collect and recycle stripping water</li> <li>Requires workers to wear respiratory and eye protection equipment</li> <li>Blasting generates high noise levels</li> <li>Mechanized applications typical due to high reaction forces</li> <li>Misapplied water jet will damage substrate</li> <li>Water can enter cavities</li> <li>Water can penetrate and/or damage joints, seals, and bonded areas</li> </ul>
o Liquid Nitrogen Cryogenic Blasting  Impact	<ul style="list-style-type: none"> <li>Eliminates HAPs and VOCs</li> <li>Uses a dry process</li> <li>No dust, fumes, or chemicals released</li> <li>Coating chips collected dry with small volume of media</li> </ul>	<ul style="list-style-type: none"> <li>Removes thick coatings of coating from a variety of coating line fixtures and tools</li> </ul>	<ul style="list-style-type: none"> <li>Environmentally clean</li> <li>No ash residue</li> <li>Low waste volume</li> <li>Eliminates water rinse</li> <li>Very fast cycle times (5 to 15 min) give high throughput rate</li> <li>Works well on thick coating buildups</li> </ul>	<ul style="list-style-type: none"> <li>Generates some solid waste containing coating chips and spent plastic media, which may be a hazardous waste</li> <li>May require ventilation system to prevent nitrogen buildup in confined spaces</li> <li>Requires worker protection from low temperatures during unloading</li> <li>Not effective on thin coating films</li> <li>Less effective on epoxies and urethanes</li> <li>Existing technology limits part size to less than 6 ft tall and 38 in diameter weight less than 400 lb per stripping cycle</li> </ul>



**Table 2. Available Cleaner Technologies for Coating Removal: Operational Aspects**

Available Technology Type	Process Complexity/ Required Skill Level	Waste Products and Emissions	Capital Cost	Energy Use	Operations Needed After Stripping	References
Plastic Media Blasting	Medium/ Medium	<ul style="list-style-type: none"> <li>• Solid coating residue and spent media waste</li> <li>• Airborne particulates</li> <li>• Noise</li> </ul>	Medium	<ul style="list-style-type: none"> <li>• Compressed air to propel blasting media</li> <li>• Energy for media recovery and recycle, dust collection, and ventilation</li> </ul>	<ul style="list-style-type: none"> <li>• Continuous separation of media from stripped coating particles and spent media during stripping</li> <li>• Remove masking</li> <li>• Dispose of spent media and contained coating residue waste.</li> <li>• Some spent thermoplastic media (even with coating residue) can be reused to make plastic parts</li> </ul>	Abbott, 1992 Bailey, 1992 Baker, 1991 Bowers-Irons et al., 1991 Capron and Wells, 1990 Composition Materials Co., 1993 Cundiff et al., 1989 Dicaire, 1990 Galliher, 1989 Groshart, 1988 <i>HazTECH News</i> , 1991 Lyons, 1990 Novak, 1990 Pauli, 1989 Roberts, 1989 U.S. DoD, 1988 U.S. Navy, 1987 U.S. Technology Corporation, 1993 Wasson and Pauli, 1993
Wheat Starch Blasting	Medium/ Medium	<ul style="list-style-type: none"> <li>• Solid coating residue and spent media waste</li> <li>• Airborne particulates</li> <li>• Noise</li> </ul>	Medium	<ul style="list-style-type: none"> <li>• Compressed air to propel blasting media</li> <li>• Energy for media recovery and recycle, dust collection, and ventilation</li> </ul>	<ul style="list-style-type: none"> <li>• Continuous collection and reuse of spent media during stripping</li> <li>• Remove masking</li> <li>• Dispose of spent media and contained coating residue waste</li> <li>• Spent media can be treated by biodegradation</li> </ul>	Drake, 1993 Larson, 1990 Lenz, 1991 Oestreich and Porter, 1992 Oestreich and Waugh, 1993
Burnoff Coating Removal	Low/ • Low for operation • High for maintenance	<ul style="list-style-type: none"> <li>• Ash</li> <li>• Offgas</li> </ul>	Medium	<ul style="list-style-type: none"> <li>• Electricity or gas supply for heating</li> </ul>	<ul style="list-style-type: none"> <li>• Cool down</li> <li>• Ash removal and collection</li> </ul>	Coberth and Ceyssons, 1993 Izzo, 1989 Mann, 1991 <i>Metal Finishing</i> , 1990 Whelan, 1993
Molten Salt Coating Removal	Low/ • Low for operation • High for maintenance	<ul style="list-style-type: none"> <li>• Salt/coating by-product sludge</li> <li>• Offgas</li> <li>• Rinse water</li> </ul>	Medium	<ul style="list-style-type: none"> <li>• Electricity or gas supply for heating</li> </ul>	<ul style="list-style-type: none"> <li>• Cool down</li> <li>• Water rinse</li> </ul>	Gat et al., 1993 Malloy, 1993 <i>Metal Finishing</i> , 1990
Sodium Bicarbonate Wet Blasting	Medium/ Medium	<ul style="list-style-type: none"> <li>• Liquid waste containing coating residue and spent media</li> <li>• Some airborne particulates</li> <li>• Noise</li> </ul>	Low	<ul style="list-style-type: none"> <li>• Compressed air and water supply to propel blasting media</li> <li>• Ventilation to control particulate</li> </ul>	<ul style="list-style-type: none"> <li>• Remove masking</li> <li>• Dispose of sodium bicarbonate solution and coating residue waste</li> </ul>	Chen and Olfenbuttel, 1993 Kline, 1991 Larson, 1990 Peebles et al., 1990 Spears, 1989 Svejkovsky, 1991 Wasson and Haas, 1990

(continued)

Table 2. (Continued)

Available Technology Type	Process Complexity/ Required Skill Level	Waste Products and Emissions	Capital Cost	Energy Use	Operations Needed After Stripping	References
Carbon Dioxide Pellet Cryogenic Blasting	Medium/ Medium	<ul style="list-style-type: none"> <li>• Solid coating residue waste</li> <li>• Airborne particulates</li> <li>• CO<sub>2</sub> gas</li> <li>• Noise</li> </ul>	Medium	<ul style="list-style-type: none"> <li>• Liquid carbon dioxide supply</li> <li>• Compressed air supply to propel blasting media</li> </ul>	<ul style="list-style-type: none"> <li>• Remove masking</li> <li>• Dispose of coating residue waste</li> </ul>	APCI, 1984b Boyce et al., 1990 Burcham, 1993 Cheney and Kopf, 1990 Cold Jet, Inc., 1989 Cundiff and Matalis, 1990 Foster et al., 1992 Ivey, 1990 Kopf and Cheney, 1989 Larson, 1990 Schmitz, 1990 Svejkovsky, 1991 Wolff, 1984
High-Pressure Water Blasting	High/ <ul style="list-style-type: none"> <li>• Low for operation</li> <li>• High for maintenance</li> </ul>	<ul style="list-style-type: none"> <li>• Sludge waste containing paint residue</li> <li>• Wastewater</li> <li>• Some airborne particulates</li> <li>• Noise</li> </ul>	High	<ul style="list-style-type: none"> <li>• Electricity to drive water pump</li> </ul>	<ul style="list-style-type: none"> <li>• Remove masking</li> <li>• Dispose of coating residue sludge and wastewater</li> </ul>	Hofacker et al., 1993 Howlett and Dupuy, 1993 Stone, 1993 U.S. Army, 1992
Medium-Pressure Water Blasting	Low/ High	<ul style="list-style-type: none"> <li>• Sludge waste containing paint residue (and in some systems solvent or abrasive additives)</li> <li>• Wastewater</li> <li>• Some airborne particulates</li> <li>• Noise</li> </ul>	Low	<ul style="list-style-type: none"> <li>• Electricity to drive water pump</li> </ul>	<ul style="list-style-type: none"> <li>• Remove masking</li> <li>• Dispose of coating residue sludge and wastewater</li> <li>• If used, dispose of abrasive or sorbent or other treatment medium carrying solvent</li> </ul>	Bailey, 1992 Boeing, 1993 Howlett and Dupuy, 1993 <i>New Scientist</i> , 1990 Petkas, 1993
Liquid Nitrogen Cryogenic Blasting	Medium/ <ul style="list-style-type: none"> <li>• Low for operation</li> <li>• High for maintenance</li> </ul>	<ul style="list-style-type: none"> <li>• Solid coating residue and spent media waste</li> <li>• Inert nitrogen gas</li> </ul>	Medium	<ul style="list-style-type: none"> <li>• Liquid nitrogen supply</li> </ul>	<ul style="list-style-type: none"> <li>• Vent nitrogen gas from the stripping cabinet</li> <li>• Allow parts to warm for 5 minutes</li> <li>• Dispose of coating residue waste</li> </ul>	APCI, 1982, 1984a, 1984b, 1985 Mathur, undated <i>Products Finishing</i> , 1983 Stroup, 1991 Wolff, 1984

are referenced in the discussions of each cleaner technology.

Some additional inspection, hand cleaning, or other operations may be needed to prepare the surface after use of the cleaner technology for coating removal. These are noted to indicate special considerations in the application of the cleaner coating removal technology.

**Process Complexity, Required Skill Level, Waste Products and Emissions, and Capital Cost** serve to qualitatively rank the cleaner technologies relative to each other. The rankings are estimated based on the descriptions and data in the literature. The text further describes the operating information, applications, benefits, known and potential limitations, technology transfer, and the current state of development for each technology. Technologies in earlier stages of development are summarized to the extent possible in Section 3, Emerging Technologies.

The last column in Table 2 cites **References** to publications that will provide further information about each available technology. These references are given in full at the end of the respective technology sections.

## Plastic Media Blasting

### Pollution Prevention Benefits

The plastic media blasting (PMB) coating removal process eliminates the use of solvent strippers. The process uses nontoxic plastic media for coating removal and does not generate volatile organic air emissions. PMB is a completely dry stripping process, thus eliminating generation of wastewater.

In most applications the plastic media are collected, cleaned to remove coating debris, and reused. The plastic particles do breakdown in use so they can not be reused indefinitely. Once the particle size is smaller than about 60 to 80 mesh, the stripping efficiency drops. These small plastic fragments, mixed with coating debris, must be discarded.

*Plastic media are nontoxic but may require disposal.*

The disposal of the spent media could be a problem. Although the plastic media are not toxic, the spent stripping medium will be contaminated with coating chips. These coating residues may contain hazardous metals or unreacted resins. The disposal options available depend on the nature of the media used and the coating stripped. If the spent media do require

disposal at a hazardous waste site, the cost will be high.

A thermoplastic material has been developed to allow recycling of spent blasting medium (Lyons, 1990). If thermoplastic media are used, it is often possible to recover the spent media for manufacture of plastic parts even with the coating chip contamination. Bioreactors are also under development to treat the spent PMB waste (Baker, 1991). It may be possible to degrade either the plastic media or the coating residue (Bowers-Irons et al., 1991). Generally, however, the spent PMB media are not recyclable or biodegradable, so disposal is required.

### How Does It Work?

The PMB process uses low-pressure air or centrifugal wheels to project plastic media at a surface. The blast particles have sufficient impact energy, coupled with hardness and geometry, to chip away or erode the coating. The sharp-faceted particles fracture on impact, leaving new sharp edges to allow continued use for stripping. After the coating has been removed, the part can be prepared for recoating by air pressure and/or vacuuming to remove plastic dust and coating debris.

The hardness of the plastic particles varies from 34 to 72 on the Barcol scale (3.0 to 4.0 on the Mohs' scale). In general, the plastic media are selected to be harder than the coating. Otherwise, a larger particle size must be used to reach the necessary impact energy level.

In typical applications, the air pressure measured in the pot ranges from 10 to 60 psi. The higher pressures remove coating faster but also are more likely to induce substrate damage.

### Operating Features

There are two basic types of PMB systems (1) cabinet systems and (2) open-blast systems. Automated and manual cabinet systems are available for stripping smaller parts. Standard cabinet dimensions typically are limited to about 8 feet. The cabinet systems provide an controlled environment for media collection and reuse. Automated cabinets use either air pressure or rotating wheels to project the media toward the parts. The parts may be in rotating baskets or can be moved through the cabinet on tracks or conveyor belts if high throughput with low labor use is needed. Manual systems involve an operator manipulating an air-powered blast nozzle. The open-blast systems are applicable for parts too large to fit into the cabinets, for example, automobiles, white goods, and aircraft. In the open systems, the operator uses a nozzle to project the air-driven blast media at the surface.

*A wide range of PMB equipment is available and blasting conditions can be selected to suit the coating and substrate.*

PMB stripping equipment may range from simple single-nozzle systems to complex multinozzle computer-controlled systems (Capron and Wells, 1990). The electronic control systems provide not only for remote control of the operating parameters, such as blasting pressure and media flow rate, but also for fully automated motion and process control, such as robotic operations (Dicaire, 1990).

The parameters that affect the performance of the PMB process include

- Blasting pressure—10 to 60 psi with an optimum range of 20 to 40 psi
- Angle of impingement—30° to 80°
- Media flow rate—250 to 500 lb/hr with a 1/2-in nozzle
- Blasting standoff distance—6 to 30 in
- Stripping rate—0.5 to 5 ft<sup>2</sup>/min
- Type of coating to be removed
- Nature of substrate material and its thickness
- Media type and size
- Nozzle size
- Masking requirements
- Types and capabilities of commercially available PMB systems (Abbott, 1992; Lyons, 1990).

During normal operations, a PMB operator will have a set of predetermined parameters to be applied to a given substrate. In the case of a complex workpiece containing parts made of several types of materials or with filled areas, the operators will adopt a blast plan with each substrate marked as to type prior to blasting.

Problems may arise when higher air pressures are used for blasting, including metal removal, reduced resistance to metal fatigue, the hiding and causing of surface cracks, and buckling. These problems have caused some controversies in the aerospace industry where materials such as aluminum and high-strength composites are required to carry dynamic or fatiguing loads.

The U.S. Bureau of Mines conducted a study of the explosibility and ignitability of plastic abrasive media for the Naval Civil Engineering Laboratory (NCEL) (U.S. Navy, 1987). The study concluded that recycled media in the size range of 12 to 80 mesh would not explode, but that particulate from degraded media had explosive potential (for example, less than 40 mesh with Type V media). The possibility for explosive condition is greatest in portions of the media recycling system

where the concentration of fines is highest, for example, a baghouse filtration system. The report suggests locating such equipment away from occupied areas, outside if possible, and providing overpressure relief vents.

*Plastic blast media can be selected to adjust the stripping rate and aggressiveness.*

Six thermoset and thermoplastic blast media have been promulgated and/or approved for use by the U.S. Department of Defense (Lyons, 1990; U.S. DoD, 1988). Specifications for a biodegradable, nonpetroleum polymer also were introduced later (Lyons, 1990). The blast media are classified by type and hardness (Barcol and/or Mohs' scale), as follows:

- Type I—polyester (thermoset), 34 - 42 Barcol, 3.0 Mohs
- Type II—urea formaldehyde (thermoset), 54-62 Barcol, 3.5 Mohs
- Type III—melamine formaldehyde (thermoset), 64-72 Barcol, 4.0 Mohs
- Type IV—phenol formaldehyde (thermoset), 3.5 Mohs
- Type V—acrylic (thermoplastic), 46-54 Barcol, 3.5 Mohs
- Type VI—polycarbonate (allyl diglycol carbonate) (thermoset), 20-30 Barcol, 3.0 Mohs
- Type VII—a nonpetroleum amyloseous polymer (biodegradable), 2.8 Mohs.

*Larger, harder media give more aggressive stripping.*

The order of media aggressiveness from mild to aggressive is Type I, Type VI, Type V, Type II, and Type III. Type I is soft abrasive that would be selected for topcoat or primer removal from soft metals or fiberglass. Type VI is intended for low-air-pressure application to removing coating from fiberglass or other composites. Higher air pressure increases the breakdown rate of Type VI media, so the application pressure is limited to about 20 psi. Type V is a durable medium for general stripping of coatings from metal sheeting. Type II, like Type V, is applied for general stripping. Type II gives faster stripping rates but is less more likely to damage the substrate if the operator deviates from stripping parameters. Type IV is similar to Type II in aggressiveness but breaks down faster and has not found much market acceptance. Type III is an aggressive, fast-acting medium for removal of topcoats and primers from hard substrates such as engine parts (Groshart, 1988; Bailey, 1992; Composition Materials Co., 1993; U.S. Technology Corporation, 1993).

Size is the second major factor controlling the aggressiveness of PMB media. Larger particles generate more aggressive stripping action. The various types of media typically are available in about five mesh size ranges. The largest standard size available is 12 to 16 mesh and the smallest is 40 to 60 mesh. The material type and particle size can be selected to optimize the PMB system to the cutting speed and gentleness required for particular application.

*Plastic media can be cleaned and reused.*

Systems to recover and reuse the plastic media have been developed. Media recovery is facilitated if the parts are small enough to allow the use of a blasting cabinet. Media reuse systems separate contaminants, such as coating chips and undersized media fragments, from the intact media. Separation can be done by cyclone separators, vibrating screens, magnetic separators, or similar equipment. The media reclamation systems typically employ a combination of these equipment types to separate contaminants and clean the spent media for reuse (Wasson and Pauli, 1993). The number of reuse cycles that can be achieved is variable. Generally large media and lower operating pressures allow more reuse cycles. Granulated plastic pellets used at pressures below 50 psi are reported to be durable with an average breakdown rate of less than 10%.

*Each application requires specific custom designs based on individual production requirements; a generic "Statement of Work" is no longer acceptable (Roberts, 1989).*

The energy requirement is determined by the complexity of each PMB system. Compressed air is required to operate the blasting system at different blasting pressures and nozzle sizes. For example, the air use is 8 SCFM for a 1/8-inch nozzle at 30 psi and 230 SCFM for a 1/2-inch nozzle at 60 psi (Dotson and Ballard, 1992). Energy is required to operate a spent media recovery subsystem that includes a pneumatic transport vacuum hose, an induced draft fan, a rotary screw conveyor, and a subfloor piping or mechanical conveying system. Energy is also consumed by the media recycling subsystem that includes a cyclone, an airwash, a vibrating screen, a rotary airlock, and pneumatic or mechanical conveyance devices. Other subsystems, such as a dense particle separator, dust collector, and ventilation system, also consume energy.

As seen in Table 2, PMB operation requires a medium skill level. Effective use of PMB requires an initial training period to familiarize the operator with the required stripping media supply pressure and the

nozzle-to-surface distance and angle. With appropriate training, operators should be able to perform the job without much difficulty.

### Application

The PMB process has been widely used by the military and commercial sectors:

- Types of coatings removed include powder coatings, urethanes, military chemical agent resistant coatings, epoxies, high solids, polyamid, acrylic lacquers, polysulfide sealants, fluorocarbon films
- Cleaning/stripping of machinery, equipment, engines, injection molds, etc.
- Cleaning/stripping of aluminum, stainless and mild steel, fiberglass and plastic totes, and tanks and containers
- Cleaning/stripping of commercial/industrial parts, components, and structures fabricated of metal, engineered plastics, fiberglass, and advanced composites
- Stripping of marine vessels and related components and assemblies
- Exterior airframe stripping
- Stripping of aircraft ground equipment
- Stripping aircraft components (e.g., wheels, brakes, landing gear, engine parts, and composite parts) (Lyons, 1990; Novak, 1990; Pauli, 1989).

*Current applications show that PMB can be economical.*

PMB stripping of a C-5 aircraft (32,000 ft<sup>2</sup>) was studied in detail at a large new Air Force installation designed for PMB stripping of B-52 and C-5 aircraft using Type V PMB media. The study indicated that PMB offers significant economic advantages over solvent stripping. The total working time for supervision, masking, blasting, demasking, sanding, vacuum and blow-off, and housecleaning was 3,010 hours. This reported to be a savings of 2,000 hours over solvent stripping of the same aircraft. The reported stripping rate, waste generation rate, and unit cost were 1.35 ft<sup>2</sup>/min, 0.22 lb/ft<sup>2</sup>, and \$4.70/ft<sup>2</sup>. The costs include electrical, labor, media use, hazardous waste disposal, and consumables. The PMB process is expected to save \$4,800,000/year and eliminate 72,000 gallons/year of methylene chloride stripper (Wasson and Pauli, 1993).

The major factors controlling costs of operating a PMB system are

- Hourly cost of direct labor
- Labor productivity rates, typically 75%

- Cost of blast media, ranging from \$1.50/lb to more than \$2.00/lb (1991 prices)
- Energy costs
- Overhead costs
- Waste disposal costs, ranging from inconsequential to up to \$4/blast-hr if hazardous waste is generated (assuming a 1/2-in nozzle at 30 psi)
- Removal rate, typically ranging from 0.5 to more than 4 ft<sup>2</sup>/min (assuming a 1/2-in nozzle at 30 psi)
- Efficiency of the media reclamation system.

Under typical operating conditions, the variable operating costs are reported to range from \$45 to \$65/blast-hr, and the cost of removal can range from \$0.20 to \$2.15/ft<sup>2</sup> (Lyons, 1990). The process can provide a high throughput rate, but the capital investment and start up costs for new system with state-of-the art media recycling equipment can be high. In most cases the PMB systems are not compatible with existing stripping facilities, so facility modifications are required.

### Benefits

Some of the major beneficial aspects of PMB include

- High stripping rate
- Eliminates water use
- Can selectively remove individual coating layers (e.g., remove topcoat leaving primer)
- Often done with recyclable thermoplastic media
- Fully automated robotic systems available
- Fully developed systems available
- No size limitations on parts to be stripped.

### Limitations

Potential hazards and limitations of PMB include

- Spent media contain coating chips and may be a hazardous waste.
- Operators should wear respiratory and eye protection equipment for protection from rebounding media and airborne particulates.
- Operators should wear hearing protection due to high noise levels from blasting equipment.
- PMB may cause metal substrate damage such as reducing resistance to metal fatigue, hiding and causing of surface cracks, and buckling.
- PMB may cause crack closure.
- More aggressive media types damage composite materials.
- Contaminants in media may damage substrate.
- PMB has potential for high disposal costs if spent media are hazardous and cannot be recycled.
- PMB uses flammable media.
- The technology has somewhat high capital and startup costs.

- PMB requires complex subsystems for media recovery and recycling and dust collection and control.
- There is a possible explosive hazard from dust.

### References

- Abbott, K. E. 1992. "Plastic Media Blasting — State of the Technology." *Materials Performance*, 31(2):38-39.
- Bailey, J. 1992. "Strip It Off." *Industrial Finishing*, 68(2):24-27.
- Baker, S. 1991. "Bugs Help Strip Old Paint in Bio-Reactor System." *Skywriter*, November 22, p. 22.
- Bowers-Irons, G., R. Pryor, and C. Miller. 1991. "The Biostripping of Polyurethane Paint." In: *Proceedings of the 1991 DOD/Industry Advanced Coatings Removal Conference*, San Diego, California. pp. 40-48.
- Capron, S., and M. Wells. 1990. "Performance Testing of Plastic Media Blasting Equipment." In: *Proceedings of the 1990 DOD/Industry Advanced Coatings Removal Conference*, Atlanta, Georgia.
- Composition Materials Company, Inc. 1993. *Plati-Grit*. Composition Materials Company, Fairfield, Connecticut.
- Cundiff, C. H., O. L. Deel, and R. E. O'Sullivan. 1989. "Plastic Media Evaluation—A Comparative Study of Performance Capabilities of Several Plastic Media." In: *Proceedings of the 1989 DOD/Industry Advanced Coatings Removal Conference*, Ft. Walton Beach, Florida.
- Dicaire, P. 1990. "Dust-Free Robotic PMB Paint-Stripping for Transport-Size Aircraft." In: *Proceedings of the 1990 DOD/Industry Advanced Coatings Removal Conference*, Atlanta, Georgia.
- Gallihier, R. D. 1989. "Surface Preparation and Paint Adhesion on Aluminum Substrate after Blasting with Plastic Abrasive." In: *Proceedings of the 1989 DOD/Industry Advanced Coatings Removal Conference*, Ft. Walton Beach, Florida.
- Groshart, E. 1988. "The New World of Finishing." *Metal Finishing*, October, pp. 33-34.
- HazTECH News. 1991. *HazTECH News*, 6(8).
- Lyons, P. J. 1990. "Plastic Media Comes of Age." *Metal Finishing*, July, pp. 43-46.

Novak, H. L. 1990. "Development and Testing of a Fluorescent Plastic Grit Blast Media." In: *Proceedings of the 1990 DOD/Industry Advance Coatings Removal Conference*, Atlanta, Georgia.

Pauli, R. 1989. "Plastic Media Blast Dry Stripping Four Years Later." In: *Proceedings of the 1989 DOD/Industry Advanced Coatings Removal Conference*, Ft. Walton Beach, Florida.

Roberts, B. 1989. "PMB, Then, Now and the Future". In: *Proceedings of the 1989 DOD/Industry Advanced Coatings Removal Conference*, Ft. Walton Beach, Florida.

U.S. Department of Defense (DoD). 1988. "Plastic Media, for Removal of Organic Coatings." Military Specification, Mil-P-85891A, 0386 DD, May 6.

U.S. Navy. 1987. *Explosibility and Ignitability of Plastic Abrasive Media*. CR 87.011, Naval Civil Engineering Laboratory, Port Hueneme, California.

U.S. Technology Corporation. 1993. *The Magic is the Media*. U.S. Technology Corporation, Canton, Ohio.

Wasson, N. E., Jr., and R. Pauli. 1993. "Dry Stripping the C-5 and B-52 in the World's Largest Dry Stripping Installation." In: *Proceedings of the 1993 DOD/Industry Advanced Coatings Removal Conference*, Phoenix, Arizona. pp. 530-540.

## Wheat Starch Blasting

### Pollution Prevention Benefits

The wheat starch blasting coating removal process eliminates the use of solvent strippers. The process uses nontoxic, biodegradable media for coating removal and does not generate volatile organic air emissions. The wheat starch blasting media are made from renewable agricultural products rather than from petroleum, which helps reduce resource consumption. Wheat starch blasting is a completely dry stripping process, and thus eliminates the generation of wastewater.

The starch media can be collected and reused for several blasting cycles. The wheat starch particles do break down in use, so they cannot be reused indefinitely. Fine dustlike particles are not effectively propelled for stripping. The starch media are processed in equipment similar to that used for processing PMB media. Small starch fragments, mixed with coating debris, are separated and discarded.

The disposal of the spent media could be a problem. Although the media are not toxic, the spent stripping media will be contaminated with coating chips. These coating residues may contain hazardous metals or unreacted resins. The disposal options available depend on the volume of the media used and the coating stripped. The wheat starch blasting media are 100% carbohydrate, so proper aerobic biodegradation can reduce the waste volume substantially. The media are digested to produce a liquid that can be separated from coating debris prior to disposal. Biodegradation is most likely to be economical when spent media volumes are on the order of 50,000 to 100,000 pounds (Oestreich and Waugh, 1993).

### How Does It Work?

Wheat starch blasting uses low-pressure air to propel particles at the painted surface. The coating is stripped away by a combination of impact and abrasion. Although wheat starch blasting uses generally similar equipment and techniques to PMB, the process has somewhat different operating characteristics and stripping action (Drake, 1993).

### Operating Features

In wheat starch coating removal, particles of wheat starch are propelled at a surface by a flow of air to abrade and fracture the coating. The natural wheat starch has the benefits of being nontoxic, biodegradable, and made from a renewable resource (Lenz, 1991). The media are clear white granules in the size range of 12 to 30 mesh with a density of 1.45 g/cm<sup>3</sup> and a Shore D hardness of 85.

Testing determined that when the propelling air pressure is above 30 psi (200 kPa), the starch particles fracture. The fracturing occurs as the starch removes coating material, resulting in smaller particles and more edges per pound of medium to be recycled as stripping proceeds. The wheat starch thus becomes more effective as it is used until the particles become so small that suspended starch dust obscures the operator's view of the surface. The used starch media are collected and processed. Small starch particles and the removed coating are collected for disposal, and the larger particles are reused for blasting. Because the media are reused continuously for coating removal, the potential arises for contamination of the media with harder coating particles. The coating particles could impact the substrate and cause stress risers.

*Wheat starch blasting uses similar equipment and techniques to PMB but the media properties result in a gentle, reliable stripping action.*

Particle fracturing reduces the sensitivity of wheat starch coating removal to operating conditions. An increase in air pressure increases particle flow rate but does not cause the stripping action to become more aggressive.

As with the plastic media, new or clean recycled wheat starch media do not present explosive hazards. Dust generation from the wheat starch raises the potential for generating an explosive dust mixture. Testing performed for a wheat starch media vendor indicates that undried dust must be smaller than 120 mesh for explosion to be a hazard. As with PMB dust, the explosive hazard from wheat starch blasting media dust is small and is limited to process areas where high concentrations of dust may accumulate. Precautions for handling wheat starch blasting media dust should be similar to those mentioned for PMB dust handling.

The reported typical blasting conditions for coating removal from composites are (Oestreich and Porter, 1992)

- Blasting pressure—20 to 25 psi
- Angle of impingement—20° to 40°
- Media flow rate—420 to 720 lb/hr with a 3/8-inch extended Venturi or double-Venturi nozzle
- Blasting standoff distance—6 to 8 in.

The reported typical blasting conditions for coating removal from clad aluminum are (Oestreich and Porter, 1992)

- Blasting pressure 25 to 30 psi
- Angle of impingement 40° to 70°
- Media flow rate 900 to 1,200 lb/hr with a 1/2-inch extended Venturi or double-Venturi nozzle
- Blasting standoff distance 8 to 12 in
- Stripping rate 0.9 ft<sup>2</sup>/min.

The wheat starch can absorb moisture causing clumping of the media during blasting. In humid conditions, it may be necessary to dry the blasting air to avoid moisture pickup by the media.

### **Application**

Wheat starch blasting is known mainly for its gentle stripping action. Therefore most of the testing and application has been on sensitive substrates such as

- Thin aluminum, particularly soft alloys or anodized surfaces (e.g., commercial aircraft skins)
- Sensitive composites (e.g., automobile fiberglass or plastic or aircraft radomes).

The wheat starch technology has been tested for stripping a variety of epoxy, urethane, zinc chromate primer, and alkyd enamel coatings such as MIL-P-23377, MIL-C-83286, and TT-E-489 (Larson, 1990). Test substrates have included aluminum, plated ferrous alloys, and composites.

### **Benefits**

Some of the major beneficial aspects of wheat starch blasting include

- Recent developments indicate that moderate stripping rates can be achieved while maintaining a gentle stripping action
- Safe on soft clad aluminum and composites
- Eliminates water use
- Can selectively remove individual coating layers (e.g., remove topcoat leaving primer)
- Uses inexpensive stripping media
- Media are nontoxic and biodegradable
- Fully developed systems available
- No size limitations on parts to be stripped.

### **Limitations**

Potential hazards and limitations of wheat starch blasting include

- Spent media contain coating chips and may be a hazardous waste
- Generally slow to moderate stripping rate
- Dense contaminants in recycled media may damage substrate
- Operators should wear respiratory and eye protection equipment for protection from rebounding media and airborne particulate
- Operators should wear hearing protection due to high noise levels from blasting equipment
- Media are moisture sensitive and can require an air dryer in humid atmospheres
- Potential for high disposal costs if spent media are hazardous and cannot be recycled or treated by biodegradation
- Somewhat high capital and startup costs
- Requires complex subsystems for media recovery and recycling and dust collection and control
- Explosive hazard from dust.



## References

- Drake, C. 1993. "Envirostrip Starch Media Dry Stripping Process Update." In: *Proceedings of the 1993 DOD/Industry Advanced Coatings Removal Conference*, Phoenix, Arizona. pp. 427-431.
- Larson, N. 1990. "Low Toxicity Paint Stripping of Aluminum and Composite Substrates." In: *First Annual International Workshop on Solvent Substitution*. DE-AC07-76ID01570, U.S. Department of Energy and U.S. Air Force. Phoenix, Arizona. pp. 53-60.
- Lenz, R. P. 1991. "Performance Characteristics of Starch Blast Media." In: *Proceedings of the 1991 DOD/Industry Advanced Coatings Removal Conference*, San Diego, California. pp. 147-188.
- Oestreich, J., and T. Porter. 1992. "Starch Media Blasting for Aerospace Finishing Applications." In: *28th Annual Aerospace/Airline Plating and Metal Finishing Forum and Exposition*, San Diego, California.
- Oestreich, J., and R. D. Waugh. 1993. "Bioremediation of Starch Media Waste." In: *Proceedings of the 1993 DOD/Industry Advanced Coatings Removal Conference*, Phoenix, Arizona. pp. 432-443.

## Burnoff Coating Removal

### Pollution Prevention Benefits

Burnoff coating removal technologies use a combination of volatilization, pyrolysis, and oxidation to remove organic coating materials. Thermal methods completely avoid the use of solvents for coating removal but generate potentially contaminated offgas and wastewater streams. In a well-designed unit, the organic materials will be almost completely converted to carbon dioxide and water. However, traces of more complex organic compounds may appear in the offgas. In addition, coatings containing halogens or nitrogen compounds will produce volatile, corrosive compounds such as hydrogen chloride. Inorganic pigments will not volatilize and thus remain as a residue on the part after the organic coating burns off. Water may be needed to scrub the pyrolysis stripping unit offgas stream and, in some systems, is used to flush inorganic residue from the stripped part.

### How Does It Work?

Burnoff systems use temperatures of 370°C (700°F) or higher to volatilize and/or burn the organic coating

material. A few metals such as mercury or arsenic will volatilize at the operating temperature of burnoff ovens. However, toxic volatile metals are not used in current paint formulations. Inorganic materials such as pigments remaining on the substrate must be removed by mechanical cleaning such as low-energy shot blast, manual cleaning, or water rinse.

### Operational Features

Burnoff systems remove coating materials rapidly. Even difficult coatings such as heavy layers of powder coating can be removed. However, the substrate is exposed to a harsh, high-temperature environment so pyrolysis coating removal is generally suitable only to noncritical items. Burnoff coating removal is not generally acceptable for parts that will be used in a product. However, the functioning of part support equipment usually is not impaired by many cycles of heating, so burnoff coating removal can be used for hooks, racks, and overspray collectors.

Burnoff coating removal can be accomplished by a variety of methods including direct burnoff, heating in an abrasive fluidized bed, or pyrolysis. In all cases a high-temperature energy source is used to remove organics followed by a cleaning process to remove inorganic residues. Inorganic residue removal can be accomplished by mechanical or manual brushing or blast cleaning with water or airborne media (Izzo, 1989). Offgas treatment including an afterburner, scrubber, and filter typically is supplied to control air pollution. To ensure safety, the system must be designed to control the intense heat resulting from the rapidly burning organic coating.

*Several burnoff technologies are available.*

For direct burnoff, the coating is ignited to burn off the organic material at an operating temperature of 540°C to 650°C (1000°F to 1200°F). Direct burnoff is suitable to continuous operation in which a conveyor carries the racks through the burnoff oven and then through a cleaning system to remove inorganic residue. As the parts pass through the burnoff unit, ceramic nozzles direct high-temperature flue gas onto the parts at high velocity to ignite the coating. Complete combustion typically occurs within the unit to ensure acceptable coating removal and suitable air pollution control at the source. With proper line speed and operating temperature, complete combustion can be obtained, but some units include an afterburner to further ensure that organic materials are fully converted to carbon dioxide and water. Burnoff also can be done in batches in a closed oven.

*Coatings can be thermally degraded in an abrasive fluid bed.*

In an abrasive fluid bed, the coating is thermally degraded by a combination of pyrolysis and partial oxidation at a temperature of 480°C to 510°C (900°F to 950°F). To maintain a fluidized state, air flows up through a bed of abrasive media such as silica sand or aluminum oxide (Coberth and Ceyssons, 1993). The hot abrasive media transfer heat to the coating to pyrolyze and remove organic constituents. After the part is removed from the fluidized bed, inorganic residues must still be removed. Heat is supplied to the abrasive media by an electrical resistance heating unit. The organic materials are not fully oxidized in the fluidized bed, so an afterburner operating at 790°C to 870°C (1450°F to 1600°F) is required to oxidize the intermediate organic products.

*Coatings are volatilized in the pyrolysis process.*

In the pyrolysis process, the coating is volatilized to produce fumes rich in organic compounds (Whelan, 1993). The combustible materials on the substrate volatilize to form an organic-rich vapor but do not burn in the pyrolysis unit. The unit, therefore, operates with low or no oxygen and at a lower temperature (370°C to 500°C (700°F to 930°F)) with no flame present in the unit.

Some coatings, notably epoxies, contain oxygen molecules bound in the coating. The oxygen in the coating can support combustion which would cause excessive temperature rise. Water vapor cloud injection controls the temperature in the pyrolysis unit to ensure no combustion takes place and to minimize damage to the substrate. Typically pyrolysis units can only process cured coating materials. The solvent and other volatiles in uncured coatings will evaporate rapidly in the pyrolysis unit. The rapid input of reacting materials will cause temperatures in the unit to rise before the control system can respond. The resulting uncontrolled temperature rise causes the pyrolysis unit to shut down to prevent excessive temperatures. Advanced control systems are being developed and tested to allow pyrolysis to be applied to uncured coatings (Mann, 1991).

Because of the need to control oxygen levels, pyrolysis units typically are batch ovens. The organic fumes from the pyrolysis unit are treated in an afterburner to convert hydrocarbons to carbon dioxide and water. Following removal from the pyrolysis unit, inorganic residues must be removed from the part.

*Burnoff gives rapid removal of thick coatings.*

Heat is the principle removal mechanism for coating removal. Although all of the thermal systems require a follow-up cleaning step to remove inorganic residues, no solvents or alkalis are used to soften and remove the coating. Despite the heating value of the organic material in the coating, heat input is needed to initiate, maintain, and complete combustion. Heat for direct burnoff or pyrolysis units usually is supplied by combustion of a fossil fuel, typically gas, in the coating removal unit. The fluidized bed units normally use electrical heating. The afterburner in all units typically uses gas or another fossil fuel to supply the required energy.

The control systems for a burnoff coating removal system are complex. Accurate temperature control is needed to ensure that complete removal of the coating and destruction of organics in the offgas is reliably achieved. The control systems for the thermal units and afterburner may be unlike equipment normally found in coating shops, so new maintenance skills are needed.

Actual operation of a burnoff coating removal unit involves only mechanical or manual loading and unloading of parts. The units are typically designed to operate automatically during the coating removal cycle, so no operator attention is needed during a normal cycle. The required skill level is, therefore, lower than the level for solvent stripping units that require the operator to handle potentially hazardous chemicals.

### **Application**

Burnoff coating removal is commonly used for high-volume, noncritical parts such as the hooks, racks, overspray collectors, or other similar parts. Burnoff methods can be used to remove both conventional and powder coatings (Mann, 1991).

It also may be possible to use the burnoff coating technology to strip parts with poor coatings, but some limitations apply. Metals with a melting point below 900°F generally are not suitable for burnoff coating removal. Magnesium will burn violently if ignited, so magnesium and its alloys should not be stripped in a burnoff oven. Iron, steel, and nontempered aluminum generally are amenable to burnoff stripping. However, testing must be performed to determine if heating deforms, removes tempering, or otherwise damages the part.

---

## Benefits

Some of the major beneficial aspects of burnoff coating removal include

- Allows rapid removal of heavy coating accumulation with a minimum of handling.
- Can process parts with complex shapes.
- Direct-burn ovens can remove wet, uncured coatings.
- Large ovens are available to process large items, but the maximum size is limited by the oven size.

## Limitations

Potential hazards and limitations of burnoff coating removal include

- Generates coating ash residue that may be hazardous waste.
- Will damage heat-sensitive materials such as heat-treated aluminum or magnets.
- Coatings containing halogens (polyvinyl chloride [PVC] or polytetrafluoroethylene [PTFE]) and/or nitrogen will produce corrosive offgas.
- Must not be used for low-melting alloys such as zinc-bearing materials.
- Must not be used for magnesium or its alloys, or for pyrophoric metals.
- May require offgas treatment, such as scrubbers and air filters, depending on local air permitting requirements
- May generate products of incomplete combustion
- Presents possibility of fire.

## References

- Coberth, D., and L. Ceyssons. 1993. "Stripping Organic Finishes with Fluidized Beds." *Metal Finishing Organic Finishing Guide Book and Directory Issue*, 91(5A):234-236.
- Izzo, C. 1989. "PF Coatings Clinic." *Products Finishing* 53(5):14.
- Mann, C. 1991. "Paint Waste Minimization by Means of Recyclable Overspray Collectors." *Product Finishing*, June, pp. 22-24.
- Metal Finishing*. 1990. "Product Showcase: Metal and Paint Strippers." *Metal Finishing*, July, pp. 36-40.
- Whelan, K. 1993. "Burn-Off Ovens for Stripping." *Metal Finishing Organic Finishing Guide Book and Directory Issue*, 91(5A):225-227.

## Molten Salt Coating Removal

### Pollution Prevention Benefits

The molten salt stripping process replaces solvent strippers. The molten salt process produces a coating pigment salt by-product residue, wastewater, and offgas streams.

During molten salt stripping, by-products of the reaction of the salt and the coating accumulate in the bath. Even when the bath is saturated with by-products, stripping will continue. Additional by-products develop as more coating is removed from a separate phase in the bath. The by-product sludge phase can be removed for disposal. The organic content of the coating will be oxidized by reaction with the salt bath. The by-product sludge is a small volume containing mostly metal salts formed by reaction of pigments with the salt bath materials. Depending on the salts used in the bath and the metals in the pigments, the sludge may have RCRA hazardous characteristics.

The wastewater results from water used to cool and rinse the part after it leaves the molten salt bath. The salt in the coating removal bath usually is formulated from alkaline materials, so for most installations the rinsewater will have a pH of about 11 to 12. The rinsewater will require neutralization to a pH range of 6 to 9 prior to discharge. For plants with a central wastewater treatment plant, it may be possible to use the alkaline rinse water to help neutralize acidic wastewater from other metal-finishing operations. The rinsewater also may contain metals from the coating pigments. Analysis for potential metals should be performed prior to discharge, and treatment for metal removal may be required depending on the plant discharge permits.

*The molten salt technology chemically oxidizes the coating organics*

As with the burnoff coating removal systems, molten salt coating removal works by combusting the coating organics. The result for hydrocarbon coatings should be mainly the formation of CO<sub>2</sub> and H<sub>2</sub>O. However, products of incomplete combustion and entrained salt particulates and pigments can enter the offgas stream. A well-designed molten salt stripping system will include provisions to control and treat the offgas.

### How Does It Work?

The molten salt stripping process relies on chemical oxidation of the coating by a specially formulated molten salt bath. The process uses mixtures of inorganic salts formulated to react with the coating material. Carbon and hydrogen in the coating are oxidized to

CO<sub>2</sub> and H<sub>2</sub>O. Most metals are retained in the molten salt bath. In sodium carbonate-based and similar molten salt formulations, halogens combine with the molten salt to form halides and to release CO<sub>2</sub> from the carbonate salts. Metals from the coating pigments generally are retained in the molten salt and enter the offgas stream only in small amounts.

The main functions of the molten salt are a heat transfer medium and catalyst to oxidize the organics in the coating. The salt bath provides thermal inertia and effective heat transfer to avoid hot spots or temperature excursions. The molten salt also acts as an in-place scrubber which retains the nonvolatile by-products (Gat et al., 1993).

### Operational Features

Molten salt stripping uses simple and straightforward processing steps. The items to be stripped are loaded into baskets or supported on hooks. The items then are lowered into the salt bath at a controlled rate. The required heating time in the bath depends on a number of variables including

- Chemistry and temperature of the bath
- Shape, size, and material of the item
- Thickness and type of coating being stripped.

The typical dwell time ranges from seconds for thin coatings to minutes for thick coatings (Malloy, 1993). Following immersion, the items are removed from the salt bath and rinsed with water for cooling and removal of residual salt. The rinsed items are dried by an air knife or other compressed air blow drying operation. The process allows rapid and complete coating removal with a minimum of hand work.

Molten salt stripping baths are formulated from inorganic salts such as sodium carbonate. The exact mixture of salts is tailored to the required operating temperature, chemical reactivity, and performance. The operating temperature for the salt bath varies, depending on the salt formulation. Formulations are available with operating temperatures from 550°F to 900°F. The lower temperature formulations usually are applied to salvage materials with blemished coatings or for maintenance stripping. Higher temperature formulations strip heavy coating accumulations from hooks, racks, and paint line fixtures.

### Application

Molten salt stripping typically is targeted to the same applications as burnoff technologies. Although the molten salt process achieves coating oxidation by a different mechanism, the process provides the same

basic features, that is, rapid destruction of thick coatings. The items most often stripped with molten salt baths are paint line supports and fixtures. Molten salt baths can remove a variety of organic coatings including nylon, polyester, and epoxies. Due to the chemistry of the bath, molten salt systems also can be applied to strip coatings containing halides, e.g., PVC and PTFE (Malloy, 1993).

### Benefits

Some of the major beneficial aspects of molten salt coating removal include

- Allows rapid removal of heavy coating accumulation with a minimum of handling.
- Can process parts with complex shapes.
- Provides rapid, well-controlled, uniform heating.
- Wastewater stream is compatible with conventional wastewater treatment plants available to many installations.
- Salt baths are available to process moderate-sized items, but the maximum size is limited by the bath size.

### Limitations

Potential hazards and limitations of molten salt coating removal include

- Generates a by-product salt sludge that may be a hazardous waste.
- Will damage heat-sensitive materials such as heat-treated aluminum or magnets.
- Must not be used for low-melting alloys such as zinc-bearing materials.
- Must not be used for magnesium, its alloys, or pyrophoric metals.
- May require offgas treatment, such as scrubbers and air filters, depending on local air permitting requirements.
- May generate products of incomplete combustion.
- Wastewater and dissolved salt disposal requirements will depend on the toxicity of the coating and pigments being removed.

### References

- Gat, U., S. M. Crosley, and R. L. Gay. 1993. "Waste Treatment for Removed Protective Coatings." In: *Proceedings of the 1993 DOD/Industry Advanced Coatings Removal Conference*, Phoenix, Arizona.
- Malloy, J. C. 1993. "Molten Salt Bath Stripping of Organic Coatings." *Metal Finishing Organic Finishing Guide Book and Directory Issue*, 91(5A):234-236.

*Metal Finishing*, 1990. "Product Showcase: Metal and Paint Strippers." *Metal Finishing*, July, pp. 36-40.

## Sodium Bicarbonate Wet Blasting

### Pollution Prevention Benefits

The sodium bicarbonate technology eliminates solvent use in coating removal. The sodium bicarbonate stripping medium is not regulated under the OSHA hazard communication standard 19 CFR 1910.1200 or the SARA Title III reporting requirements. The stripping medium is mixed with water, which controls dust and substrate heating. Water also is used to rinse the substrate after stripping is complete. As a result, an aqueous waste stream is generated. Although the medium is nontoxic, many coatings contain metals or unreacted resins that are toxic. The spent media will contain coating residue, so the aqueous waste must be tested to determine if it will meet local discharge limits for wastewater disposal. Testing should include quantifying pH, total suspended solids (TSS), oil and grease, and metal concentrations. If desired, the media can be dissolved in excess water and the solid coating residue can be removed by filtration. Even if waste treatment or landfill disposal is needed, the total solid waste volume generated by the sodium bicarbonate technology typically would be less than for methods using solvents.

### How Does It Work?

The sodium bicarbonate (baking soda) is delivered by a wet blast system to remove coating in this way: Compressed air moves the sodium bicarbonate medium from a pressure pot to a nozzle where the medium mixes with a stream of water. The blast medium/water mixture, accelerated to several hundred miles per hour, impacts the coated surface and shatters into a very fine particulate. The water prevents heat buildup in the substrate and helps control the dust generated when the media impact on the coating.

### Operational Features

The sodium bicarbonate coating removal technology operates mainly by abrasive action. The wet blast system delivers a mixture of blast medium and water through a hand-held, hand-actuated blast nozzle, shown in Figure 1. The flow diagram (Figure 2) illustrates a typical configuration of the system.

The exact operating conditions are specific to the type of coating and the substrate type and configuration. The typical range for bicarbonate stripping applications is (Spears, 1989):

- Blasting pressure—20 to 70 psi
- Angle of impingement—45 to 90°

- Media flow rate—2 to 4 lb/min with a 1/2-in nozzle
- Water flow rate—0.5 gpm
- Blasting standoff distance—12 to 24 in
- Stripping rate—0.25 to 2.5 ft<sup>2</sup>/min.

*Bicarbonate blast conditions can be selected to suit the coating and substrate.*

Other important parameters in bicarbonate coating removal system operation are

- Type of coating to be removed
- Nature of substrate material and its thickness
- Media type and size
- Nozzle size
- Masking requirements
- Types and capabilities of commercially available systems.

*Various bicarbonate media are available to allow balance of stripping rate and aggressiveness.*

Typically a nontoxic flow agent is included in the bicarbonate media to minimize caking in the blast pot. The media come in six formulas to provide different mesh sizes for different applications:

- Composite formula
- Maintenance formula<sup>(a)</sup>
- Maintenance formula XL<sup>(a)</sup>
- Profile formula
- Aviation formula
- Electronics formula.

The wet blast system uses a pressurized nozzle designed to allow a low propellant pressure while maintaining a positive abrasive flow. The low pressure of the air propellant minimizes damage to aluminum, plastic composites, and other sensitive materials. Operators can adjust the blast pressure to remove one layer of coating at a time. The pressure of the water can vary between 10 and 500 psi. The air requirement is determined by blasting pressure and nozzle size. For example, when blasting at 60 psi for a 1/2-in nozzle, 265 cfm of air is required; that, in turn, requires a minimum of 66 HP electric compressor.

As seen in Table 2, sodium bicarbonate blasting requires a medium skill level. Abrasive media blasting requires an initial training period to familiarize the operator with the required stripping media supply pressure and the nozzle-to-surface distance and angle.

<sup>a</sup> Maintenance formula and Maintenance formula XL are available with SupraKleen Rinse Accelerator to improve removal of surface contaminants or heavy coating, if needed.

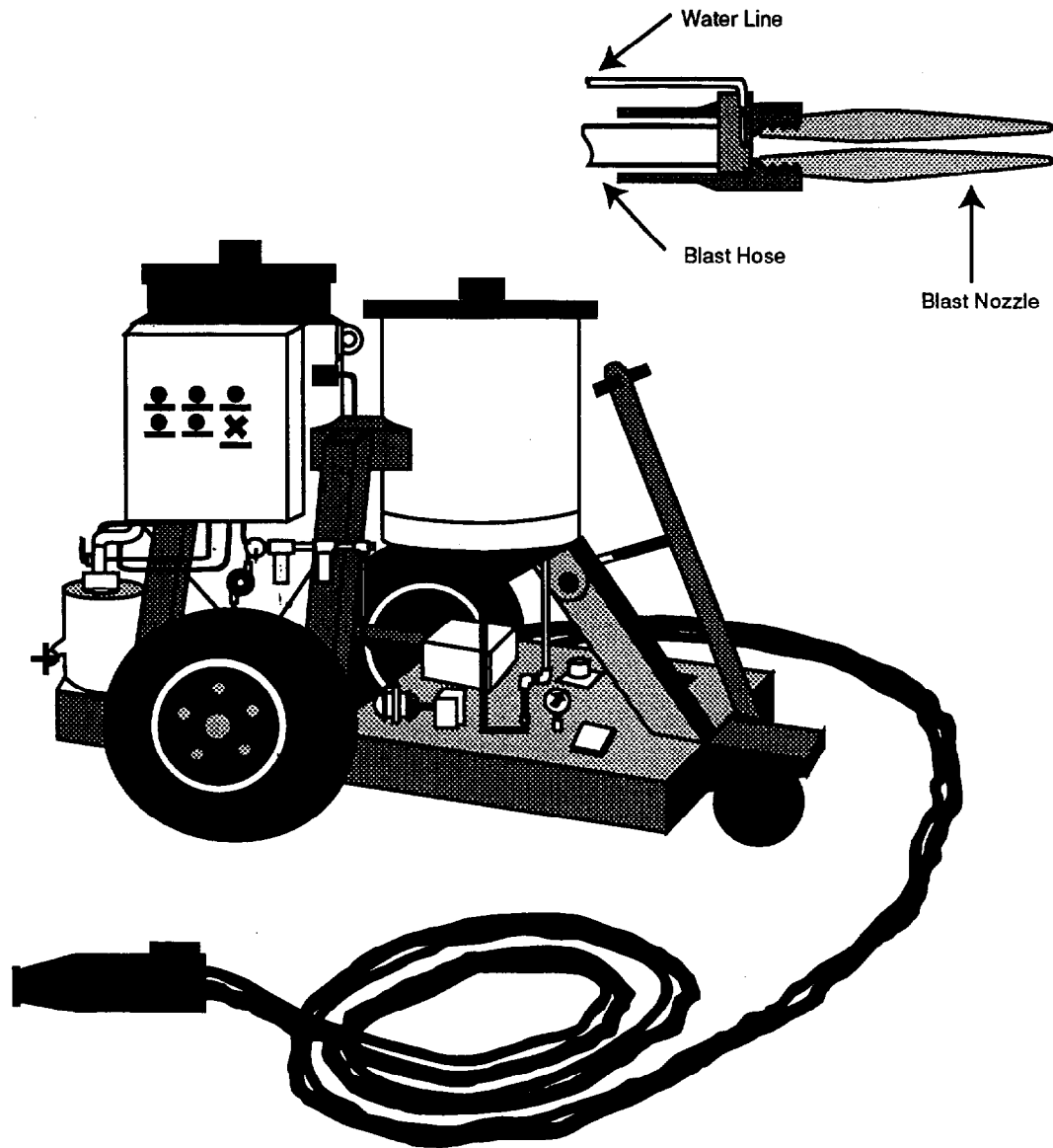

Source: Schmidt Manufacturing, Inc.

**Figure 1. Sodium bicarbonate system with wet blast head.**

With appropriate training, operators should be able to perform the job without much difficulty.

*Equipment for sodium bicarbonate wet blasting is relatively inexpensive.*

Sodium bicarbonate blasting uses modified sandblasting equipment and is less expensive than equipment for PMB, wheat starch blasting, or carbon dioxide pellet blasting.

The sodium bicarbonate medium costs more than traditional abrasive media such as sandblasting, but is relatively inexpensive compared to PMB. Startup costs

may include facility revamping to allow installation of the wet blast system. An exhaust ventilation system with cyclone separator and intake piping must be added to control blast media overspray if the sodium bicarbonate coating removal system is used indoors. The sodium bicarbonate process often can be applied in existing solvent stripping facilities, which also saves investment in facility revisions.

**Application**

The technology has been applied for removal of both friable and elastomer organic coatings. Substrate materials include thin and thick metal parts, machinery, and building surfaces. Sodium bicarbonate or similar

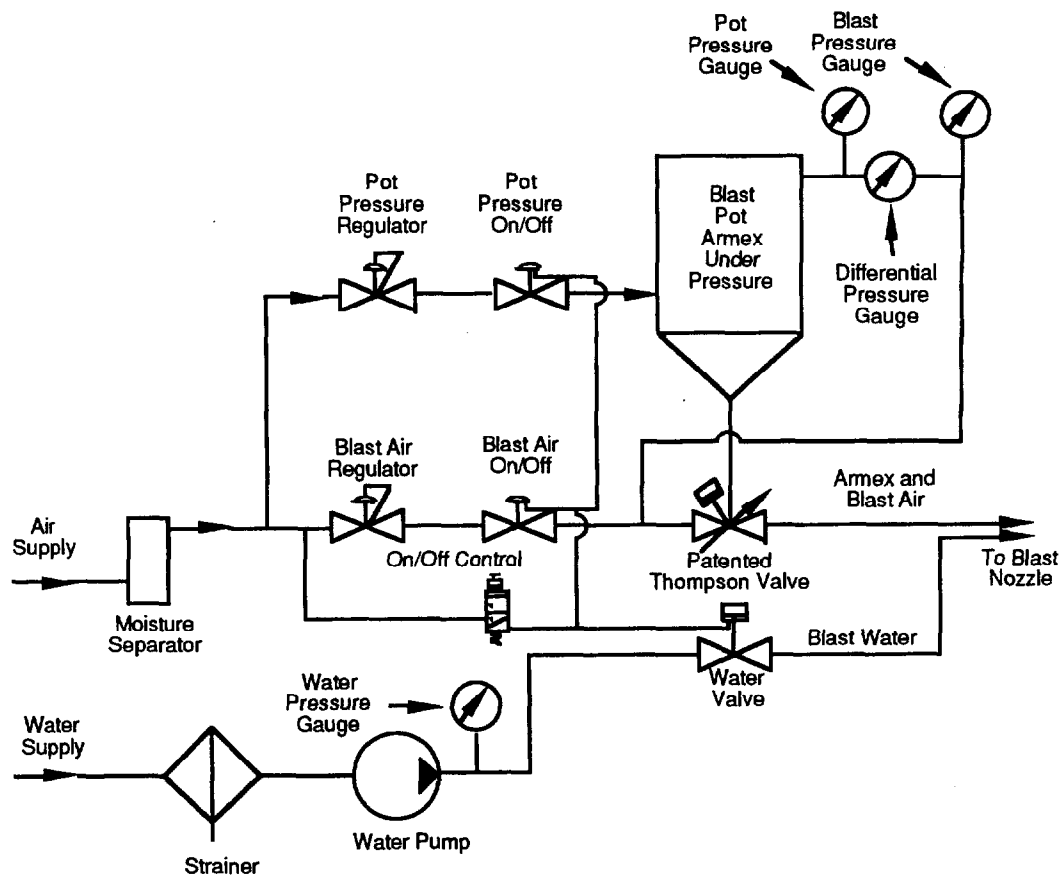

Source: Schmidt Manufacturing, Inc.

Figure 2. Flow diagram of sodium bicarbonate wet blast system.

water-soluble abrasive technology has been tested or applied to the following:

- Remove failing topcoat over a tight red lead primer on structural steel
- Clean and decoat surfaces of historical buildings, including 19th century buildings in Manchester, England; the Parliament building and the Opera House in Vienna, Austria; the Statue of Liberty in New York; and the Mormon Church in Salt Lake City, without damaging sensitive surfaces
- Clean, in situ, disbonded coating from paper mill roller bearings
- Remove grease buildup from drive unit of paper machine dryer
- Remove graffiti from sandstone wall and factory-finished metal siding
- Clean railcar wheels prior to magnetic particle inspection
- Decoat diesel locomotive sheet metal door (sandblasting had warped the panels)
- Clean valving with thick coating buildup on natural gas vaporizing tank
- Clean dirt and coating residue from aircraft parts without disassembling (Kline, 1991).

The NASA Johnson Space Center (JSC) Aircraft Operation Division has used sodium bicarbonate to strip the surface of aircraft wheels prior to inspecting for cracks and structural defects. Prior to use of the sodium bicarbonate product, NASA used a phenolic-based stripper and another earlier chemical stripper containing methylene chloride and other organic solvents. Both stripping formulations required repetitive soaking, and the costs for disposal of the solid and liquid wastes they generated were high (Chen and Olfenbuttel, 1993).

Tennessee Eastman has used the sodium bicarbonate stripping to remove coating from equipment during operation. The paper and pulp industry also has used the technology for cleaning paper production equipment in place.

### Benefits

Some of the major beneficial aspects of sodium bicarbonate wet blasting include

- High stripping rate
- Can selectively remove individual coating layers (e.g., remove topcoat leaving primer)

- In some applications, bicarbonate stripping can reduce prewashing and masking of the surface needed prior to stripping
- Use of water dissipates the heat generated by the abrasive process and reduces the amount of dust in the air
- Wastewater stream is compatible with conventional wastewater treatment plants available to many installations
- Low-cost stripping media and simple stripping equipment
- No size limitations on the parts to be stripped.

### Limitations

Sodium bicarbonate coating stripping has several potential hazards and limitations:

- The sodium bicarbonate medium cannot be recycled for stripping.
- Operators should wear respiratory and eye protection equipment for protection from rebounding media and airborne particulate.
- The sodium bicarbonate blasting medium does not pose a health risk, but the coating chips being removed may. Airborne particulates generated during coating stripping may contain toxic elements from the coating being removed. An exhaust ventilation system should be used during sodium bicarbonate coating removal to remove the particulate cloud that forms as the blast medium strikes the surface.
- Operators should wear hearing protection due to high noise levels from blasting equipment.
- Uninhibited sodium bicarbonate and water residue can corrode substrates; however, current testing indicates that the corrosion potential of uninhibited formulations is similar to that of organic solvent strippers.
- Wastewater and bicarbonate residue disposal requirements will depend on the toxicity of the coating and pigments being removed.
- Slug discharge of bicarbonate (over about 3,000 ppm) can adversely affect the operation of an anaerobic digester.

### References

- Chen, A. S. C., and R. F. Offenbuttel. 1993. "Evaluating Bicarbonate of Soda Blasting Technology: Its Potential in Pollution Prevention and Waste Reduction." In: *American Institute of Chemical Engineers — 4th Pollution Prevention Topical Conference*.
- Kline, E. S. 1991. "Sodium Bicarbonate Blasting." *Painting & Wallcovering Contractor*, July-August, pp. 85-86, 95.

Larson, N. 1990. "Low Toxicity Paint Stripping of Aluminum and Composite Substrates." *First Annual International Workshop on Solvent Substitution*. DE-AC07-76ID01570, U.S. Department of Energy and U.S. Air Force. Phoenix, Arizona. pp. 53-60.

Peebles, H. C., N. A. Creager, and D. E. Peebles. 1990. "Surface Cleaning by Laser Ablation." *First Annual International Workshop on Solvent Substitution*. DE-AC07-76ID01570, U.S. Department of Energy and U.S. Air Force. Phoenix, Arizona.

Spears, W. E. 1989. "Mechanical Test Program." Paper presented at Bicarbonate of Soda Stripping Technical Interchange Meeting. Southwest Research Institute, San Antonio, Texas, June 21.

Steiner, R. 1993. "Carbon Dioxide's Expanding Role". *Chemical Engineering*, 100(3):114-119.

Svejkovsky, D. 1991. "Carbon Dioxide Paint Removal Status." In: *Proceedings of the 1991 DOD/Industry Advanced Coatings Removal Conference*, San Diego, California. pp. 344-393.

Wasson, N. E., Jr., and M. N. Haas. 1990. "Sodium Bicarbonate Blasting for Paint Stripping." *First Annual International Workshop on Solvent Substitution*. DE-AC07-76ID01570, U.S. Department of Energy and U.S. Air Force. Phoenix, Arizona.

## Carbon Dioxide Pellet Cryogenic Blasting

### Pollution Prevention Benefits

Carbon dioxide (CO<sub>2</sub>) stripping generates a smaller amount of waste than all of the available technologies and some of the emerging thermal technologies. Upon impacting the surface being cleaned or decoated, the CO<sub>2</sub> pellets disintegrate and sublime, that is, they pass directly from solid to gaseous state without appearing in the liquid state. Because the CO<sub>2</sub> pellets return to the gaseous state after use, the process does not generate a spent media residue. The coating residue is collected dry, without extraneous plastic beads, grit, or other impacting material. Thus, no recycling or separation of the media from the coating residue is required.

The carbon dioxide pellets are produced from liquid CO<sub>2</sub>. The liquid CO<sub>2</sub> is prepared industrially as a by-product of ammonia manufacturing (35%), alcohol and other chemical production (22%), oil and gas refining (20%), or by collecting and purifying CO<sub>2</sub> gas from natural gas vents (20%) or combustion process offgas (3%) (Steiner, 1993). The purified CO<sub>2</sub> is compressed and liquefied. The CO<sub>2</sub> from these sources would enter the atmosphere if it were not captured for industrial



use, so carbon dioxide pellet blasting makes no net addition of new CO<sub>2</sub>.

The coating surface need not be washed before or after CO<sub>2</sub> blasting. The process removes dirt, oil, and grease while stripping coatings, so these surface contaminants do not interfere with the stripping action. Because the media are not recycled, there is no need for concern about dirt, oil, or grease contaminating the media. In addition, because the pellets sublime, no media remain behind to contaminate the substrate, so no poststripping rinse is needed. As a result, CO<sub>2</sub> pellet blasting does not produce a wastewater stream and thus eliminates the need for wastewater treatment.

### How Does It Work?

The carbon dioxide blasting systems have a refrigerated liquid CO<sub>2</sub> supply and a system for converting the liquid to the solid media used in coating removal. Compressed liquid is allowed to expand in a pressure-controlled chamber where the temperature drops from about -37°C (-35°F) to about -78°C (-109°F). The temperature drop on expansion causes a mixture of CO<sub>2</sub> vapor and solid CO<sub>2</sub> snow to form. The snow is collected, compressed, and extruded through a die to produce well-defined pellets of a selected size and hardness as needed for the specific coating removal operation.

CO<sub>2</sub> pellet blasting applies a blast medium much the same way as does PMB. Compressed air or liquid nitrogen thrusts small CO<sub>2</sub> pellets at a coated surface. Because the CO<sub>2</sub> reverts to a gas, the stripping media do not contaminate the substrate (Ivey, 1990). A system for centrifugal acceleration of the pellets also is under development (Foster et al., 1992).

The actual mechanism for coating removal is, however, different in CO<sub>2</sub> pellet blasting. The CO<sub>2</sub> pellets remove the coating by a combination of impact, embrittlement, thermal contraction, and gas expansion. The importance of each of these mechanisms in achieving coating removal is not yet defined.

*CO<sub>2</sub> blasting uses a combination of impact and thermal mechanisms to remove the coating.*

Unlike the other two processes that rely on impact and abrasion (PMB and wheat starch blasting), the frozen CO<sub>2</sub> pellets provide thermal shock, or cracking. They cryogenically sever the bond between the substrate and coating. When the CO<sub>2</sub> pellets sublime upon impact, the expanding gas can help remove the coating. The air pressure blows the coating fragments off the substrate. On multicoat surfaces, the pellets rupture the weakest bond.

Depending on the application, CO<sub>2</sub> pellets can be propelled toward the substrate at subsonic, sonic, or supersonic speed. The pellets typically are propelled at an impingement angle of between 30° and 75° to remove the coating. The more severe the angle of impingement, the more aggressive is the process. The best angle and standoff depend on the coating material and substrate. In one test, the optimal removal rates occurred at an impingement angle of 75° with a stand-off distance of 2 in.

Due to the low temperatures generated by CO<sub>2</sub> blasting, water condensation from the atmosphere can be a problem. The gas supply to the blasting system must be dry. The gas supply may be either dry air or nitrogen.

### Operating Features

CO<sub>2</sub> pellet cryogenic blasting is best applied if there is a high penalty for contaminating the substrate surface, if disassembly is difficult or expensive, or if the residue resulting from coating removal is a high-hazard material. For example, CO<sub>2</sub> pellet cryogenic blasting can be used to clean radioactive-contaminated components. Its use dramatically reduces the radioactive waste volume because no media remain behind to become contaminated.

The CO<sub>2</sub> pellet technology can be custom configured for mobile, manual, fixed, or automated, online production applications for use in a wide range of industries, including

- Food processing
- Automotive manufacturing
- Electronics
- Aerospace.

A dry compressed air stream expels CO<sub>2</sub> pellets through a gun and nozzle assembly (Boyce et al., 1990). The pellets impinge on the coated surface and remove the coating by a combination of mechanisms. The main process parameters for CO<sub>2</sub> cryogenic stripping are

- Pellet size
- Pellet density
- Blast pressure
- Angle of impingement
- Media flow rate
- Blasting standoff distance
- Nozzle design (Svejkovsky, 1991).

Optimizations typically change the propelling air pressure, impingement angle, or standoff distance (Larson, 1990).

*CO<sub>2</sub> blasting gives a slow, gentle stripping action.*

With regard to a frequently mentioned limitation, slowness, the reported coating removal rate for manual CO<sub>2</sub> pellet blasting ranges from 1.5 ft<sup>2</sup>/min to 0.1 ft<sup>2</sup>/min, depending on the substrate being stripped and the coating color (Ivey, 1990; Cundiff and Matalis, 1990). The net average strip rate on an F-16 aircraft was 0.189 ft<sup>2</sup>/min per minute of nozzle time (0.13 ft<sup>2</sup>/min with worker effectiveness factored in) (Ivey, 1990). The strip rate increased as the nozzle was widened. The Alclad™ surfaces pulled the net average down. The tested F-16 has 20% Alclad™ surfaces; other U.S. Air Force aircraft have up to 80% Alclad™ surfaces. Thus, strip rates will slow considerably on equipment with a higher percentage of Alclad™ surfaces.

In fact, the process as tested cannot remove all the coating from Alclad™ surfaces. The Alclad™ surface left by CO<sub>2</sub> pellet blasting must be removed by another process to provide an adequate surface for recoating.

Held at chest level, the blast nozzle and hose weigh about 20 lb. When blasting underneath the aircraft, another 10 lb of thrust is added. In tests, workers traded off the duty to other workers every 15 min. The newer automated systems are easier to work with, strip faster, and are safer on sensitive materials because the optimal pressure and impingement angle can be maintained.

*Special techniques can increase the stripping rate for CO<sub>2</sub> blasting.*

The preliminary results indicate that combining CO<sub>2</sub> pellet blasting with other technologies may improve CO<sub>2</sub> pellet blasting performance in certain applications. Combinations considered in the literature are

- CO<sub>2</sub> pellets + flashlamp vaporization to enhance effectiveness of the flashlamp process alone and to get where the flashlamp cannot reach (Burham, 1993)
- CO<sub>2</sub> pellets + chemical softener (i.e., benzyl alcohol) to speed up the stripping rate
- CO<sub>2</sub> pellets + laser vaporization to enhance effectiveness of the laser alone.

Preliminary studies indicate that none of these combined technologies comes close to the overall desirability of using CO<sub>2</sub> pellets alone. However, further testing may reveal that one or more of these combined technologies has a specialized application or may be useful on thin-skin materials. The combinations may make CO<sub>2</sub> more cost-effective to use. As currently

defined, CO<sub>2</sub> pellets used alone damage unsupported aluminum alloys that are less than 0.032 in thick. The peening damage caused by the pressures required for effective stripping could prevent use of CO<sub>2</sub> on up to 20% of cargo aircraft skins (Ivey, 1990).

Chemical softeners applied before CO<sub>2</sub> pellet blasting would allow less blasting pressure and thus decrease damage to thin-skin aluminum. Chemical softeners also would provide more thorough and faster stripping at well over 1 ft<sup>2</sup>/min but could require aircraft preprocessing tasks such as degreasing and masking and would generate more disposable waste. Softeners could damage aircraft materials (Ivey, 1990).

Combined with flashlamp vaporization, CO<sub>2</sub> pellet cryogenic blasting may be useful on thin-skin materials. The CO<sub>2</sub> + flashlamp combination may increase stripping speed to 3 ft<sup>2</sup>/min and promises to reduce the aggressiveness of the CO<sub>2</sub> pellets used alone (Ivey, 1990).

*Improvements have been made to make CO<sub>2</sub> cryogenic blasting systems easier to handle.*

Assistive devices have been developed to make the blast nozzle and hose less bulky. These save on the time needed for stripping and improve stripping quality. The robotic system at least doubles the stripping rate. The improved technology using either robotics or manipulator arms could provide the precision needed to avoid peening damage on thin aluminum skins (Ivey, 1990).

The material requirements include

- Tank of liquid CO<sub>2</sub> (supply ranging from 181 kg/hr to 658 kg/hr)
- Skid-mounted unit (compressor with maximum output of 430 psi, pelletizing unit, propellant system, etc.)
- Variety of nozzle assemblies
- Minimum 30 ft<sup>2</sup> of work area
- Optional robot or manipulator arms
- Breathing apparatus if CO<sub>2</sub> levels rise above 1.5% for 10 min or 0.5% for continuous use, or dust masks if breathing apparatus not needed
- Electricity to freeze the CO<sub>2</sub> pellets and accelerate them (@ \$ .10/lb or \$40/hr in 1984 \$).

Figure 3 shows a set of typical CO<sub>2</sub> blast system components.

With the nonautomated nozzles and hoses, operators require strength and stamina. The evolving automated equipment will require a medium level of skill to control

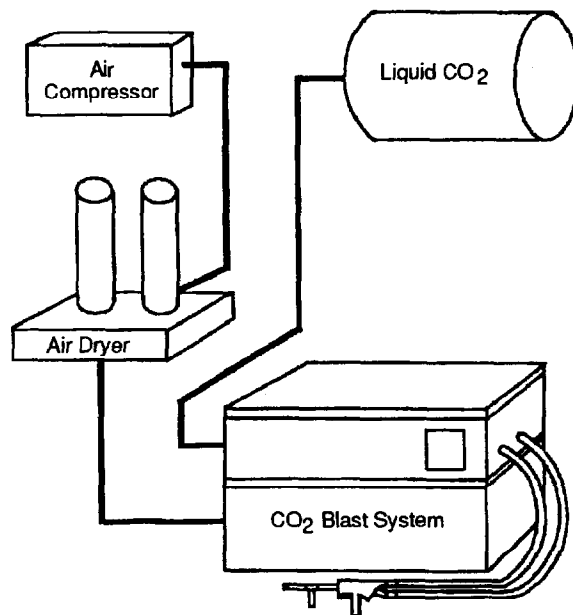

Source: Alpheus, 1990

Figure 3. A typical liquid CO<sub>2</sub> blast system.

the pressure relative to distance. Operators must take care not to damage the thinner substrates.

Potential operator exposure to high levels of CO<sub>2</sub> also is a concern with CO<sub>2</sub> pellet blasting. The greatest health concern presented by CO<sub>2</sub> is the risk of suffocation (Steiner, 1993). An atmosphere with at least 19.5% oxygen generally is considered safe. At 19.5% oxygen, if the remainder is CO<sub>2</sub>, the atmosphere is unsafe. For continuous exposure during an 8-hour workshift, OSHA sets an acceptable maximum concentration of 1% CO<sub>2</sub> in air.

Depending on the degree of automation adopted, CO<sub>2</sub> pellet blasting could involve high capital cost and relatively low labor cost. The capital cost is greater than for PMB. To strip a large part within a reasonable amount of time would require multiple nozzles. A high continuous throughput application would be needed to justify the capital cost of a CO<sub>2</sub> system.

CO<sub>2</sub> eliminates many of the costs associated with chemical processes and with some of the other cleaner coating removal technologies. By eliminating such costs as pre- and poststripping cleanup, media disposal, media separation/recycling, and aqueous waste disposal costs, the overall system cost for CO<sub>2</sub> stripping can be competitive. For example CO<sub>2</sub> stripping is reported to have an average cost of \$5/ft<sup>2</sup> for typical applications. The CO<sub>2</sub> cost compares favorably to the reported cost of \$19+/ft<sup>2</sup> for available chemical processes (Schmitz, 1990).

## Application

CO<sub>2</sub> pellet cryogenic blasting has undergone field testing on F-16 aircraft frames. It is not considered aggressive enough to remove polyurethane topcoat (Kopf and Cheney, 1989).

More than 50 systems have been custom-configured for direct or contractor applications worldwide for the automotive, military aircraft, and food processing industries.

The CO<sub>2</sub> cryogenic technology can be applied near moving parts without interrupting the power source. It can be used on sensitive electronic components that would be damaged by other cleaning technologies (Cold Jet, Inc., 1989).

CO<sub>2</sub> pellet blasting has been investigated for possible use as an aircraft coatings removal process (Ivey, 1990). This technology has successfully cleaned up mould tools, coating jigs, extruder screws, and general grease and oil contamination.

## Benefits

Some of the major beneficial aspects of CO<sub>2</sub> pellet cryogenic blasting include

- CO<sub>2</sub> media vaporize, leaving only a small volume of dry coating residue waste
- Eliminates water use
- Has a clean and well-defined coating removal pattern (Cundiff and Matalis, 1990)
- Can selectively remove individual coating layers (e.g., remove topcoat leaving primer)
- Pre- or poststripping cleanup requirements typically are minimal
- No masking is needed except for delicate materials such as soft, clear plastics
- Equipment can be stripped without requiring disassembly
- No separation/recycling system needed.
- No media disposal costs incurred
- Pellets driven into interstitial spaces vaporize, leaving no residue
- Benign to most substrates; surface damage minimal for a clad or bare surface (Cundiff and Matalis, 1990)
- No size limitations on parts to be stripped.

## Limitations

Hazards and limitations of CO<sub>2</sub> pellet blasting include

- Generates solid waste containing coating chips, which may be hazardous; however, media do not add to the volume

- Ventilation required to avoid potentially dangerous CO<sub>2</sub> concentrations in the coating-stripping area (>1.5% short-term or > 0.5% 8-hr average)
- Possible worker exposure to extreme cold
- Operators should wear respiratory and eye protection equipment for protection from rebounding media and airborne particulates
- Operators should wear hearing protection due to high noise levels from blasting equipment
- Rebounding pellets may carry coating debris and contaminate the work area or workers
- Large local temperature drops can occur but are confined mainly to the surface layer
- There is potential hazard from compressed air and/or high-velocity CO<sub>2</sub> pellets
- Static energy can build up if no grounding is provided (Cundiff and Matalis, 1990)
- Some coating debris may redeposit on substrate
- Low temperature can cause condensation on substrate
- A slight quantity of coating particles are emitted to the air, requiring a standard air filtration system
- May damage thermoset composite materials unless close attention is paid to dwell time and stand-off distance
- Difficult to control coating removal on graphite-epoxy composites, perhaps because of brittleness (Cheney and Kopf, 1990)
- Slight reduction of fatigue life of metal substrates (Cundiff and Matalis, 1990)
- Peens and damages soft aluminum less than 0.020 in thick (Larson, 1990)
- Particularly slow on Alclad™-coated aluminum skins and thermoset composites
- Nonautomated system fatigues workers quickly because of cold, weight, and thrust of blast nozzles (Ivey, 1990; Wolff, 1984).

## References

- Alpheus. 1990. *CO<sub>2</sub> Cleanblast*. Alpheus Cleaning Technologies, Rancho Cucamonga, California.
- APCI (Air Products and Chemicals, Inc.). 1984. *Coatings Removal Competitive Technology Review*. Allentown, Pennsylvania. Rev. 1, November 19.
- Boyce, G., L. Archibald, and P. Andrew. 1990. "Cryogenic Blasting as a Tool Cleaning Process." In: *Proceedings of the 1990 DOD/Industry Advanced Coatings Removal Conference*, Atlanta, Georgia. pp. 261-303.
- Burcham, D. H. 1993. "FLASHJET Coatings Removal Process." In: *Proceedings of the 1993 DOD/Industry Advanced Coatings Removal Conference*, Phoenix, Arizona. pp. 316-333.
- Cheney, J., and P. Kopf. 1990. "Paint Removal and Protective Coating Development." In: *Proceedings of the 1990 DOD/Industry Advanced Coatings Removal Conference*, Atlanta, Georgia. pp. 372-395.
- Cold Jet, Inc. 1989. *The Force of Nature*. Videotape presentation, Loveland, Ohio.
- Cundiff, C., and T. Matalis. 1990. "A Preliminary Evaluation of Paint Removal by a Carbon Dioxide Pellet Blast System." In: *Proceedings of the 1990 DOD/Industry Advanced Coatings Removal Conference*, Atlanta, Georgia. pp. 304-329.
- Foster, C. S., P. W. Fisher, C. C. Tsai, and D. E. Schechter. 1992. "A Centrifuge Accelerator CO<sub>2</sub> Pellet Cleaning System." In: *Third Annual International Workshop on Solvent Substitution*, U.S. Department of Energy and U.S. Air Force, Phoenix, Arizona.
- Ivey, R. B. 1990. "Carbon Dioxide Pellet Blasting Paint Removal for Potential Application of Warner Robins Managed Air Force Aircraft." *First Annual International Workshop on Solvent Substitution*. DE-AC07-76ID01570, U.S. Department of Energy and U.S. Air Force, Phoenix, Arizona. pp. 91-93.
- Kopf, P. W., and J. Cheney. 1989. "Paint Removal from Composite Substrates: Advances, Abrasives, Cryogenics, and Eximer [sic] Lasers." In: *Proceedings of the 1989 DOD/Industry Advanced Coatings Removal Conference*, Ft. Walton Beach, Florida. pp. 122-169.
- Larson, N. 1990. "Low Toxicity Paint Stripping of Aluminum and Composite Substrates." *First Annual International Workshop on Solvent Substitution*. DE-AC07-76ID01570, U.S. Department of Energy and U.S. Air Force, Phoenix, Arizona. pp. 53-60.
- Schmitz, W. N. 1990. "CO<sub>2</sub> Pellet Blasting for Paint Stripping/Coatings Removal." *First Annual International Workshop on Solvent Substitution*. DE-AC07-76ID01570, U.S. Department of Energy and U.S. Air Force, Phoenix, Arizona. pp. 11-13.
- Svejkovsky, D. 1991. "Carbon Dioxide Paint Removal Status." In: *Proceedings of the 1991 DOD/Industry Advanced Coatings Removal Conference*, San Diego, California. pp. 344-393.
- Wolff, E. B. 1984. *The Impact of EPA and OSHA Regulations on Paint Stripping*. Air Products and Chemicals, Inc., Allentown, Pennsylvania.

---

## High-Pressure Water Blasting

### Pollution Prevention Benefits

High-pressure water blasting eliminates the use of chemical strippers containing HAPs. However, wastewater is generated that contains paint debris. The stripping water can be recycled to reduce waste volume. The spent stripping water must be collected and then either processed for reuse in the stripper or treated for disposal. Unlike dry stripping processes, water stripping does not generate dust.

### How Does It Work?

High-pressure waterjet stripping removes coating with a stream of water projected from specially designed nozzles at pressures of 15,000 psi to 30,000 psi or more. High-pressure pumps supply water to a system of rotating nozzles that spray the water stream onto the coated surface. The coating is removed by the kinetic impact of the water stream.

### Operational Features

High-pressure water stripping will be performed by robotically manipulated equipment to control nozzle movement over the surface to be stripped. Process development testing for stripping polyurethane topcoat from primed and clad 2024-T3 aluminum alloy used a nozzle travel rate of 1.25 in/sec and rotation speed of 400 rpm. Additional operating conditions included (Stone, 1993):

- Blasting pressure maximum 24,000 psi
- Blasting standoff distance 1.3 in
- Stripping rate 1.25 to 1.7 ft<sup>2</sup>/min.

### Application

The U.S. Air Force currently is supporting development of a Large Aircraft Robotic Paint Stripping facility (Hofacker et al., 1993). The facility is designed to use high-pressure water blasting in a fully automated system. Aircraft to be stripped include B-52, C-135, E-3, and B-1.

The U.S. Navy is developing a high-pressure water/garnet abrasive slurry stripping system for paint removal and surface preparation on ship surfaces. Testing of a manual system was completed, and a semi-automatic system has been designed and assembled. The system operates with a water pressure higher than 35,000 psi. The blasting slurry is discharged through a rotating blasting head with four nozzles. The reported stripping rate is about 2.5 ft<sup>2</sup>/min. The estimated cost of the high-pressure blasting

system is \$150,000, and the unit cost of the garnet abrasive is \$300/ton (U.S. Army, 1992).

### Benefits

Some of the major beneficial aspects of high-pressure water blasting include

- The technology has a high stripping rate.
- Stripping water is recycled.
- Wastewater stream is compatible with conventional wastewater treatment plants available to many installations.
- There are no size limitations on parts to be stripped.

### Limitations

Potential hazards and limitations of high-pressure water blasting include

- Coating debris sludge may be a hazardous waste.
- Wastewater and residue disposal requirements will depend on the toxicity of the coating and pigments being removed.
- A system must be available to collect, filter, and recycle stripping water containing coating debris (and in some systems abrasives).
- Workers must be protected from direct impingement of water jet due to extreme danger from >15,000 psi water jet.
- Robotic applications are required due to high reaction forces and high hazard from water jet.
- There is a high capital cost for the robotic system.
- A misapplied water jet will damage the substrate.
- The blasting operation generates high noise levels.
- Water can enter cavities.
- Water can penetrate and/or damage joints, seals, and bonded areas.

### References

- Hofacker, S. A., D. W. See, and W. A. Cain. 1993. "The Large Aircraft Robotic Paint Stripping (LARPS) System." In: *Proceedings of the 1993 DOD/Industry Advanced Coatings Removal Conference*, Phoenix, Arizona. pp. 476-489.
- Howlett Jr., J. J., and R. Dupuy. 1993. "Ultrahigh-Pressure Water Jetting for Deposit Removal and Surface Preparation." *Materials Performance*, 32(1):38-43.

Stone, A. 1993. "An Evaluation of High Pressure Waterjet as an Alternative Paint Removal Method: Summary of the Large Aircraft Robotic Paint Stripping (LARPS) Process Validation." In: *Proceedings of the 1993 DOD/Industry Advanced Coatings Removal Conference*, Phoenix, Arizona. pp. 400-515.

U.S. Army. 1992. *Installation Restoration and Hazardous Waste Control Technologies*. CETHA-TS-CR-92053, U.S. Army Corps of Engineers, Toxic and Hazardous Materials Agency, Aberdeen Proving Ground, Maryland.

## Medium-Pressure Water Blasting

### Pollution Prevention Benefits

Medium-pressure water blasting eliminates the use of chemical strippers containing HAPs. However, wastewater is generated containing paint debris. The stripping water can be recycled to reduce waste volume. The spent stripping water must be collected and then either processed for reuse in the stripper or treated for disposal. In some applications the water may contain small quantities of alcohol or a similar organic solvent. Unlike dry stripping processes, water stripping does not generate dust.

### How Does It Work?

Medium-pressure water blasting removes coatings with a stream of water projected from specially designed nozzles at pressures of 3,000 psi to 15,000 psi. Heavy-duty pumps, typically in the 15 to 600 hp range, supply water at high pressure. The water is sprayed through a nozzle or system of rotating nozzles onto the coated surface. The coating is removed by the kinetic impact of the water stream. The stripping action often is supplemented by presoftening with an alcohol solvent or by including soft or hard abrasives in the water stream.

### Operational Features

Water-jet blasting has been used on an industrial scale for many years to clean a variety of corrosion, grease, or other deposits from metal surfaces (Howlett and Dupuy, 1993). Several implementations of medium-pressure water blasting for coating removal are being developed and have reached varying stages of maturity. Variations include water blasting alone, water blasting with a solvent presoak, and water propelling abrasive media such as sodium bicarbonate. Systems using water only or water with a solvent presoak typically use a rotating nozzle. Systems with abrasive propelled by water typically use a fan nozzle.

Portable water-blasting stripping systems are in use for stripping floor gratings in paint booths. Two or four nozzles are carried on a rotating fixture. Several of the rotating nozzle assemblies are mounted in an enclosure. The enclosure has wheels so it can be moved over the booth floor. The rotating nozzles spray a high-pressure water stream onto the booth floor. The enclosure protects the operator and prevents the spread of water spray and paint debris (Bailey, 1992).

In response to a West German governmental directive to minimize VOC emissions in industrial processes, the German airline Lufthansa developed the Aquastripping process to strip old coating from aircraft (*New Scientist*, 1990). Water stripping is preceded by a 3-hour dwell time presoak with an alcohol softener. The water stripping is performed by manually controlled mechanized arms, each carrying rotating nozzles for the bulk of the aircraft surface. One recent implementation uses six nozzles on one stripping head (Boeing, 1993). The nozzle rotation speed is 3,500 rpm. The undersides of the wings are stripped with a counterbalanced hand-manipulated stripping nozzle. Operating conditions include

- Blasting pressure maximum 7,350 psi typical 5,100 psi
- Water flow rate 50 gpm
- Blasting standoff distance 1 to 4 in
- Stripping rate 5 ft<sup>2</sup>/min.

*Medium-pressure water blasting systems combined with abrasives such as sodium bicarbonate are being tested.*

Medium-pressure water blasting systems are also being developed using abrasive additives. One system being tested uses bicarbonate as the abrasive (Petkas, 1993). The system differs from the low-pressure bicarbonate blasting system in that the operating pressure is higher, resulting in much lower abrasive use rate. Reported test conditions for stripping clad and bare 2024-T3 aluminum are

- Blasting pressure—3,000 psi
- Angle of impingement—45°
- Media flow rate—1.0 to 1.75 lb/min
- Stripping rate—0.56 ft<sup>2</sup>/min to 0.69 ft<sup>2</sup>/min.

### Application

The automotive industry has found medium-pressure water stripping to be very efficient for cleaning floor grates, overhead conveyers, rails, and part support hooks in water wall spray paint booths (Bailey, 1992). Portable water-spray units provide removal rates in the range of 15 to 30 ft<sup>2</sup>/min. No abrasive is used and the stripping water is not recycled. The paint booth water

collection and treatment system is used to handle the stripping water.

A prototype test facility for medium-pressure water blasting with sodium bicarbonate abrasive is planned for installation at Warner Robbins Air Force Base in early 1994.

### Benefits

Some of the major beneficial aspects of medium-pressure water-jet stripping include

- Low implementation cost using simple, robust equipment
- High stripping rates
- Wastewater stream is compatible with conventional wastewater treatment plants available to many installations
- No size limitations on parts to be stripped.

### Limitations

Potential hazards and limitations of medium-pressure water-jet stripping include

- Coating debris sludge may be a hazardous waste.
- Wastewater and residue disposal requirements will depend on the toxicity of the coating and pigments being removed.
- A system must be available to collect, filter, and recycle stripping water containing coating debris (and in some systems abrasives or alcohol softener).
- Workers must be protected from direct impingement of water jet.
- Operators should wear respiratory and eye protection equipment for protection from water spray and airborne particulate.
- Operators should wear hearing protection due to high noise levels from blasting equipment.
- Mechanized applications are typical due to high reaction forces and high hazard from water jet.
- A misapplied water jet will damage the substrate.
- Water can enter cavities.
- Water can penetrate and/or damage joints, seals, and bonded areas.

### References

Bailey, J. 1992. "Strip It Off." *Industrial Finishing* 68(2):24-27.

Boeing. 1993. "Paint Stripping." *1993 Structure Conference*. SE-ACM-3-1-93, Boeing Commercial Airplane Group, Section 10, Service Engineering.

Howlett Jr., J. J., and R. Dupuy. 1993. "Ultrahigh-Pressure Water Jetting for Deposit Removal and Surface Preparation." *Materials Performance* 32(1):38-43.

*New Scientist*. 1990. "Cold-Water Treatment for Painted Planes." *New Scientist*, August, p. 35.

Petkas, P. J. 1993. "A WhiteMetal Inc. Innovation — The BOSS System That Really Works Technically and Cost Effectively." In: *Proceedings of the 1993 DOD/Industry Advanced Coatings Removal Conference*, Phoenix, Arizona. pp. 466-475.

## Liquid Nitrogen Cryogenic Blasting

### Pollution Prevention Benefits

The liquid nitrogen cryogenic coating stripping process eliminates solvent use and results in no ash or residual to clean. No fumes, smoke, or chemicals are released. A small volume of coating residue and spent plastic blasting media are collected dry for disposal. If hazardous metals or unreacted resins are present, the residue may be a hazardous waste. Liquid nitrogen is used to cool the part and to help propel plastic bead blasting media. The process does not use air to propel the media, so neither dust nor wastewater is generated (Stroup, 1991).

### How Does It Work?

Unlike the classical solvent technologies that address the chemical properties of coatings, cryogenic coating removal addresses their physical properties, i.e., the coefficient of thermal contraction and the cryogenic brittle transition temperature. The cryogenic technology takes advantage of extreme cold to embrittle and shrink the coating. The part to be stripped is cooled by a readily available cryogenic fluid, liquid nitrogen. Nitrogen is inert, colorless, odorless, noncorrosive, and noncombustible.

The liquid nitrogen is sprayed on items to be stripped as they rotate on a spindle within a stainless steel cryogenic chamber. The liquid nitrogen chills the coating, causing greater thermal contraction of the coating than of the substrate. Tensile stresses thus develop within the coating and make it brittle. High-velocity, nonabrasive plastic pellets (media) are then blasted by centrifugal throw wheels to make the coating crack, debond, and break away from the substrate.

The fixtures emerge from the chamber clean. The dry coating residue and plastic media are collected and separated so that the media can be reused. Meanwhile, the liquid nitrogen warms and evaporates,

changing back to a gas. The harmless nitrogen gas is vented out to the atmosphere where it originally came from (APCI, 1984a).

## Operational Features

Liquid nitrogen cryogenic coating removal works well for removal of heavy coating buildups such as those that accumulate on coating line fixtures. The heavy coating buildups can interfere with parts loading and maintenance service to these fixtures. For electrostatic coating application systems, the supports must be clean to promote good electrical contact between the part and the holder. Typical coating line fixtures include

- Coating hangers
- Conveyor racks
- Masks
- Grates (APCI, 1982; Products Finishing, 1983).

Removal of acrylic, alkyd, lacquer, polyester, and vinyl coatings has been successful; removal of epoxy and urethane coatings has been less successful (APCI, 1984a; Mathur, undated). However, Products Finishing (1983) reports successful stripping of urethane coatings and adds phenolics to the list. According to APCI (1984a) and Mathur (undated), coating thicknesses ranging from 0.010 to 0.500 in give the best results; coatings thinner than 0.010 in do not readily debond. Products Finishing (1983) reports success on tests on film as thin as 0.005 in, depending on the formulation.

*Liquid N<sub>2</sub> cryogenic blasting uses cold supplemented by impact to provide rapid removal of thick coatings, particularly from paint line equipment.*

Parts to be stripped (except hooks) are placed on a loading tree and lifted onto a rotating spindle at the top of the cryogenic chamber. The refrigerant liquid nitrogen coats the surface so that the impact of the plastic pellets debonds and knocks off the cracked coating chips. The residue of coating and plastic media collects at the bottom of the chamber and is conveyed to a separator. The separator divides the residue into oversized chips, media, and undersized chips. The media are returned by conveyor back to the throw wheels.

Most coatings become brittle if subjected to temperatures that are below -73°C (-100°F). Cryogenic coating removal relies on the boiling temperature of nitrogen (-196°C [-320°F]) to embrittle and shrink the coating so that the high-velocity, nonabrasive plastic pellets can knock off the coating particles without damaging the fixture. The process requires a chamber and components specially designed and built for low-temperature

use. Figure 4 shows the chamber, rotating spindle, and separation areas.

*The media can reach recesses and shaded surfaces.*

Operators manage and optimize the decoating process from a control panel. They can program temperature, blast time, wheel speed, and media flow for automatic operation, or they can control these variables manually. Interlock systems must be provided to protect operators from the intense cold and the rotating equipment. The outer door can be opened between cycles, but the inner door prevents entry to the cryogenic chamber. Guards and covers shield all moving parts.

One cycle lasts 5 to 15 min (typically 10 min). Although the cryogenic technology works best when all parts are readily exposed to the two throw wheels, the high-velocity, turbulent plastic media cloud can reach recesses and shaded surfaces on repeated rebounds at such high velocity. Hooks touching adjacent hooks have been effectively cleaned around the entire circumference (APCI, 1984a).

*Energy requirements for liquid N<sub>2</sub> cryogenic blasting are low.*

A typical cryogenic system includes a stainless steel cryogenic chamber with double doors, a liquid nitrogen delivery system, a rotating fixture support, two centrifugal throw wheels, conveyors, and a media-coating cyclone separator with a hopper for recycled media. The total system occupies a length, width, and height of 16 ft x 15 ft x 12 ft.

The cryogenic technology requires no heat. Energy requirements, therefore, are low. The compressed air requirement is 1 cfm @ 90 psig. A small amount of electricity (10 kW) is used to condense air into liquid nitrogen and to operate the throw wheels and conveyors (APCI, 1982, 1984a).

The actual operation of cryogenic stripping is relatively simple, once the appropriate operating cycle is established for the specific parts and coatings to be stripped. The required skill level for routine loading and stripping is, therefore, lower than for solvent stripping units, which require the operator to handle potentially hazardous chemicals.

The cryogenic stripping equipment is, however, more complex than stripping tanks. The equipment for the cryogenic system may be unlike other equipment in a typical small- or medium-sized coating shop, so new maintenance skills may need to be learned.



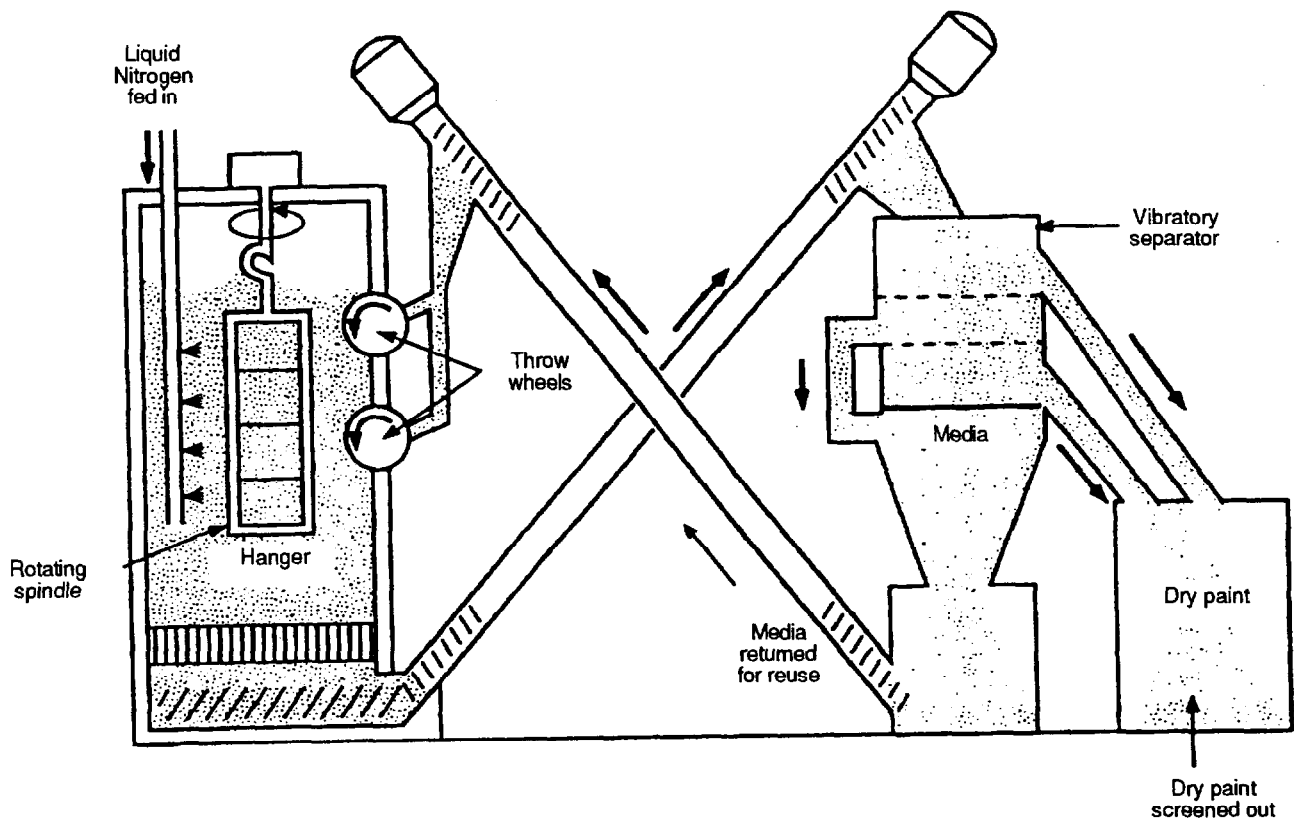

Figure 4. Operation of cryogenic coating removal process equipment.

### Application

The equipment used in cryogenic coating stripping is costly. In 1984, the system cost \$130,000 plus a royalty fee of \$10,000. The operating cycle cost of \$5 to \$15 (APCI, 1984b) combines with the high throughput to bring the cost down when frequent use justifies the capital outlay. Because of its speed, labor costs are reduced.

When throughput requirements are high enough to justify the equipment purchase, cryogenic coating stripping can reduce the costs of:

- Hazardous solvent sludge disposal
- Cleaning after stripping
- Facility damage from fire or explosion
- Measures to ensure worker safety (APCI, 1984a; Mathur, undated).

*Payback within 1 year is possible using the liquid N<sub>2</sub> cryogenic blasting technology.*

A major auto manufacturer reported payback within 1 year on a prototype cryogenic coating removal system (Products Finishing, 1983).

Factors that influence the operating cost are

- Average loading of the system
- Mass and surface area of the fixtures
- Coating type and thickness
- Tradeoffs of cycle time vs. cooling
- Unload-reload interval.

One appliance maker uses a cryogenic coating removal system to strip its inventory of more than 13,000 coating hangers and racks. The cryogenic system removes the baked-on overspray acrylic coating in 10-min cycles. Loads range from 12 to 60 hangers, averaging 375 hangers/day. Stripping costs averaged about \$0.54 each in 1985 dollars. The dry coating chips are collected in a drum for disposal.

The company reports no damage to its fixtures from the cold. Workers can handle the parts without gloves 5 to 10 min after removal from the cryogenic chamber (APCI, 1985).

The high capital cost of cryogenic coating stripping equipment has limited the breadth of industrial application. However, the technology is used to rapidly

---

remove heavy layers of coating in applications requiring high throughput.

### Benefits

Some of the major beneficial aspects of liquid nitrogen cryogenic blasting include

- No ash residue
- Low waste volume
- Coating waste chemically unaltered
- Eliminates water rinse
- Very fast cycle time (5 to 15 min)
- High throughput rate
- Works well on thick coating buildups.

### Limitations

Potential hazards and limitations of liquid nitrogen cryogenic stripping include

- Generates small volume of coating chips and spent plastic media which may be hazardous due to coating constituents.
- May require ventilation system to avoid potentially dangerous nitrogen concentrations in the coating-stripping area.
- Requires workers to wear long sleeves and gloves during unloading.
- Not effective on thin coatings (those of  $\leq 0.010$  in).
- Less effective on epoxies and urethanes.
- Existing technology limits part size to less than 6 ft tall and 38 inches in diameter.
- Part weight limited to less than 400 lb per cycle.

### References

- APCI (Air Products and Chemicals, Inc.). 1982. *Cryo-Strip™ Cryogenic Coating Removal System*. Air Products and Chemicals, Inc., Allentown, Pennsylvania.
- APCI (Air Products and Chemicals, Inc.). 1984a. *Freezing Paint for Removal*. Reprinted from May 1984 issue of *Industrial Finishing*. Hitchcock Publishing Company.
- APCI (Air Products and Chemicals, Inc.). 1984b. *Coatings Removal Competitive Technology Review*, Rev. 1. Air Products and Chemicals, Inc., Allentown, Pennsylvania.
- APCI (Air Products and Chemicals, Inc.). 1985. "Stripping Paint Hangers Cryogenically." Reprinted from January 1985 issue of *Industrial Finishing*. Hitchcock Publishing Company.
- Mathur, A. Undated. Untitled paper on cryogenic coating removal. Air Products and Chemicals, Inc., Allentown, Pennsylvania.
- Products Finishing*. 1983. "Cryogenic Paint Stripping." PF Special New Product Report. Reprinted from December 1982 issue of *Products Finishing*. Gardner Publications, Cincinnati, Ohio.
- Stroup, G. D. 1991. Letter from Stroup of Air Products and Chemicals, Inc. (APCI), Allentown, Pennsylvania, to Lawrence Smith of Battelle, Columbus, Ohio, about the APCI patented CCR™ (Cryogenic Coating Removal) process. September 27.
- Wolff, E. B. 1984. *The Impact of EPA and OSHA Regulations on Paint Stripping*. Air Products and Chemicals, Inc., Allentown, Pennsylvania.

---

## SECTION 3 EMERGING TECHNOLOGIES

### How To Use the Summary Tables

Three emerging cleaner coating removal technologies are evaluated in this section, namely

- Laser heating
- Flashlamp heating
- Ice crystal blasting.

Tables 3 and 4 summarize descriptive and operational aspects of these technologies. Readers are invited to refer to the summary tables throughout this discussion to compare and contrast technologies.

#### Descriptive Aspects

Table 3 shows the main **Coating Removal Mechanism(s)** of each emerging technology. It lists the **Pollution Prevention Benefits, Reported Application, Benefits, and Limitations** of each emerging cleaner technology.

#### Operational Aspects

Table 4 shows the key operating characteristics for the emerging technologies. This table and Table 3 give users a concise indication of the range of technologies covered to allow preliminary identification of technologies that may be applicable to specific situations. Tables 3 and 4 contain evaluations or annotations describing each emerging cleaner technology.

*The summary tables will help identify possible candidate cleaner technologies.*

In Table 4, **Process Complexity** is qualitatively ranked as "high," "medium," or "low" based on such factors as the number of process steps involved and the number of material transfers needed. **Process Complexity** is an indication of how easily the new technology can be integrated into existing plant operations. A large number of process steps or input chemicals, or multiple operations with complex sequencing, are examples of

characteristics that would lead to a high complexity rating.

*Use the information in the text, from the references, and from industry and trade groups to get more detail on the best candidates.*

The **Required Skill Level** of equipment operators also is ranked as "high," "medium," or "low." **Required Skill Level** is an indication of the level of sophistication and training required by staff to operate the new technology.

A technology that requires the operator to adjust critical parameters would be rated as having a high skill requirement. In some cases, the operator may be insulated from the process by complex control equipment. In such cases, the operator skill level is low but the maintenance skill level is high.

Table 4 also lists the **Waste Products and Emissions** from the emerging cleaner technologies to indicate tradeoffs in potential pollutants, the waste reduction potential of each, and compatibility with existing waste recycling or treatment operations at the plant. The **Capital Cost** and **Energy Use** columns provide a preliminary measure of process economics. The **Capital Cost** is a qualitative estimate of the initial cost impact of the engineering, procurement, and installation of the process and support equipment compared to current coating removal equipment.

Due to the diversity of cost data and the wide variation in plant needs and conditions, it is not possible to give specific cost comparisons. Cost analysis must be plant-specific to adequately address factors such as the type and age of existing equipment, space availability, throughput, product type, customer specifications, and cost of capital. Where possible, sources of cost data are referenced in the discussions of each cleaner technology.

**Table 3. Emerging Cleaner Technologies for Coating Removal: Descriptive Aspects**

Technology/ Coating Removal Mechanism	Pollution Prevention Benefits	Reported Application	Benefits	Limitations
Laser Heating  Thermal	<ul style="list-style-type: none"> <li>Replaces solvents</li> <li>Produces a volume of ash residue smaller than the original coating volume</li> </ul>	<ul style="list-style-type: none"> <li>Provides coating removal and/or cleaning</li> <li>Often used in conjunction with CO<sub>2</sub> pellet blasting</li> <li>Best when used with robotic systems</li> </ul>	<ul style="list-style-type: none"> <li>Results in a very small volume of waste</li> <li>Requires minimal training</li> <li>Allows topcoat to be stripped without removing primer</li> <li>No substrate damage detected under a variety of conditions</li> <li>Does not damage electronic components or change metallurgical properties</li> <li>Can remove coating between clamped to gether surfaces to a depth of 1.32 in</li> <li>Does not damage composites</li> <li>Control systems can be minimal</li> <li>Particulates easy to collect for disposal</li> </ul>	<ul style="list-style-type: none"> <li>Requires offgas collection and filtration for particulates</li> <li>Requires laser barrier wall to protect workers from lethal energy laser beam</li> <li>Requires air flow or other collection mechanism to prevent ash redeposition on the substrate</li> <li>Can generate products of incomplete combustion</li> </ul>
Flashlamp Heating  Thermal	<ul style="list-style-type: none"> <li>Replaces solvents</li> <li>Produces a small volume of ash waste</li> </ul>	<ul style="list-style-type: none"> <li>Provides coating removal and/or cleaning</li> <li>Often used in conjunction with CO<sub>2</sub> pellet blasting</li> </ul>	<ul style="list-style-type: none"> <li>Results in a very small volume of waste</li> </ul>	<ul style="list-style-type: none"> <li>Requires offgas collection and filtration for particulates</li> <li>Can generate products of incomplete combustion</li> <li>Leaves oily residue on substrate</li> </ul>
Ice Crystal Blasting  Impact/ Abrasive	<ul style="list-style-type: none"> <li>Replaces solvents</li> <li>Media are nontoxic</li> <li>Produces a small volume of coating chip waste</li> </ul>	<ul style="list-style-type: none"> <li>Good for use in confined space such as submarine interior</li> <li>Useful on aluminum and composite substrates</li> </ul>	<ul style="list-style-type: none"> <li>Generates low volume of dry waste (none from the media)</li> <li>No media separation/recycling system needed</li> </ul>	<ul style="list-style-type: none"> <li>Generates small volume of coating chips, which may be a hazardous waste</li> <li>Potential for worker injury from high-velocity ice pellet impact</li> <li>Requires workers to wear respiratory and eye protection equipment</li> <li>Requires workers to wear hearing protection</li> </ul>

**Table 4. Emerging Cleaner Technologies for Coating Removal: Operational Aspects**

Emerging Technology Type	Process Complexity/ Required Skill Level	Waste Products and Emissions	Capital Cost	Energy Use	Operations Needed After Stripping	References
Laser Heating	High/ <ul style="list-style-type: none"> <li>Low for operation</li> <li>High for maintenance</li> </ul>	<ul style="list-style-type: none"> <li>Solid ash consisting primarily of pigment</li> </ul>	High	<ul style="list-style-type: none"> <li>Electricity supply to laser</li> <li>Ventilation to control particulate</li> </ul>	<ul style="list-style-type: none"> <li>Offgas collection of particulates during stripping</li> <li>Removal of ash residual</li> </ul>	Head, 1990 Hill, 1993 Toohey, 1993
Flashlamp Heating	High/ <ul style="list-style-type: none"> <li>Low for operation</li> <li>High for maintenance</li> </ul>	<ul style="list-style-type: none"> <li>Solid ash consisting primarily of pigment</li> </ul>	High	<ul style="list-style-type: none"> <li>Electricity supply to flashlamp</li> <li>Ventilation to control particulate</li> </ul>	<ul style="list-style-type: none"> <li>Offgas collection of particulates during stripping</li> <li>Removal of ash residual</li> </ul>	Larson, 1990
Ice Crystal Blasting	Medium/Medium	<ul style="list-style-type: none"> <li>Solid coating residue waste</li> <li>Airborne particulates</li> </ul>	Medium	<ul style="list-style-type: none"> <li>Compressed air to propel blasting media</li> <li>Refrigeration to prepare ice crystals</li> </ul>	<ul style="list-style-type: none"> <li>Remove masking</li> <li>Dispose of coating residue waste</li> </ul>	Apple and Jahn-Keith, 1993 Larson, 1990 Pauli, 1993

Some additional inspection, hand cleaning, or other operations may be needed to prepare the surface after use of the cleaner technology for coating removal. These are noted to indicate special considerations in the application of the cleaner coating removal technology.

**Process Complexity, Required Skill Level, Waste Products and Emissions, and Capital Cost** serve to qualitatively rank the cleaner technologies relative to each other. The rankings are estimated based on the descriptions and data in the literature.

The text further describes the operating information, applications, benefits, and limitations, as known for each emerging technology. More highly developed technologies are discussed in Section 2, Available Technologies.

The last column in Table 4 cites References to publications that will provide further information about each emerging technology. These references are given in full at the end of the respective technology sections.

## Laser Heating

Removal of coatings using laser energy involves heating the coating with laser radiation to vaporize thin layers of material. The coating is removed by sweeping the laser beam over the surface to be stripped. The coating material absorbs energy from the laser. The rapid heating action oxidizes organic in the coating to CO<sub>2</sub> and H<sub>2</sub>O. Production of organic products of incomplete combustion has not been quantified.

Metals and other nonvolatile portions of the coating form particulate ash. A vacuum air removal system, possibly supplemented by compressed air blowoff, collects the ablated particulate to prevent redeposition or escape into the surrounding air space. The offgas can be passed through filters to remove the particulate. Laser heating has the potential to reduce the final disposal volume to less than the original volume of coating material due to combustion of the organic elements in the coating.

Laser coating removal relies on heating the coating by absorption of light energy. Coatings with low light absorbance, typically light-colored or glossy surfaces, are less amenable to removal by laser systems. Uncontrollable variations in the thickness of the coating being stripped make optimization of the laser coating removal difficult.

A commercial vendor has both used a 10-W pulsed laser to develop data on laser cleaning of aircraft materials and developed higher-powered modular

systems for full-scale applications. The new modular systems have a laser beam generator and a manually operated beam delivery arm. Pulse frequency varies directly with power in the higher-powered systems.

Pulsed laser stripping of coating requires offgas collection in filtration bags to remove the particulates, which are primarily the coating pigments. In tests, these particulates either did not deposit on the filter housing or they plugged and shortened the life of the filters. The coating particulates are collected on the filter for disposal or recycling (Head, 1990).

Laser paint removal has been tested for removal of topcoat and primer from smooth aluminum, smooth steel, textured iron, fiberglass, and carbon fiber/resin composite. The testing indicated that laser pulse duration, timing, and energy density could be selected and controlled to remove coating without substrate damage (Hill, 1993).

*Laser systems can give rapid, controlled coating removal but require complex hardware.*

A Laser Automated Decoating System (LADS) is being developed for the U.S. Air Force Ogden Air Logistics Center in cooperation with the Aeronautical Systems Center RAMTIP office. The system will be designed to remove coating from F-16 radomes. The planned system consists of the following subsystems (Toohey, 1993):

- Beam Delivery Subsystem (including turning mirrors, a beam director head, and the beam enclosures)
- Material Handling Subsystem (including a holding fixture, lathe head, and lathe bed)
- Vision Imaging Subsystem
- Waste Collection Subsystem
- Control Subsystem
- Pulsed Laser Subsystem.

*Advantages must be weighed against limitations.*

Laser coating removal has several potential advantages:

- The waste is small (ash from noncombustible coating materials).
- Combination of robotic control with visual overcheck can remove coating in a well-controlled manner.
- No substrate damage has been detected under a variety of conditions, including coating removal from composite materials.

- Laser-cleaned substrates show good coating adhesion and corrosion resistance.
- Laser stripping does not damage electronic components or change metallurgical properties (Head, 1990).

Some of the limitations of laser coating removal systems include

- The laser systems have a high capital cost and are best used with robotic controls.
- It is difficult to focus and control the laser beam to allow stripping of curved or complex surfaces.
- The use of high-power lasers for coating removal requires the use of a Class 1 laser enclosure to ensure worker protection.
- Coating removal efficiency is affected by coating color and gloss
- The potential for production of products of incomplete combustion has not been quantified.

## References

Head, J. D. 1990. "Pulsed Laser Cleaning." In: *Proceedings of the 1990 DOD/Industry Advanced Coatings Removal Conference*, Atlanta, Georgia. pp. 256-260.

Hill, A. E. 1993. "Physical Requirements and Methodology Necessary to Achieve Controllable, Damage Free Coatings Removal Using A High Energy Pulsed Laser." In: *Proceedings of the 1993 DOD/Industry Advanced Coatings Removal Conference*, Phoenix, Arizona. pp. 304-316.

Toohy, J. A. 1993. "Laser Automated Decoating System (LADS)." In: *Proceedings of the 1993 DOD/Industry Advanced Coatings Removal Conference*, Phoenix, Arizona. pp. 278-303.

## Flashlamp Heating

Flashlamp coating removal is similar to laser coating removal but with the thermal energy input from a xenon flashlamp rather than from a laser. A high-intensity flash from the lamp is focused on the surface to heat and vaporize the coating. A special lens must be used to focus the light for each different part of the configuration to be stripped.

A review of the literature indicated that flashlamp heating has the following characteristics (Larson, 1990). Dark, low-gloss coatings could be removed at a rate of 1.0 ft<sup>2</sup>/min. However, as with laser coating removal systems, light or glossy surfaces were difficult to strip. Metal surfaces reflected the light and therefore

were not damaged, but composites absorbed light and were removed in layers analogous to coating.

Flashlamp stripping leaves an oily layer on the stripped surface, so final cleaning with CO<sub>2</sub> pellet blasting or a similar process is needed. A system combining xenon flashlamp and CO<sub>2</sub> pellet blasting in a single pass is under development as discussed in the section on CO<sub>2</sub> pellet cryogenic blasting in Available Technologies (Section 2). Acutely toxic gases are released if polyurethane coatings are vaporized in an inadequate oxygen flow.

## Reference

Larson, N. 1990. "Low Toxicity Paint Stripping of Aluminum and Composite Substrates." *First Annual International Workshop on Solvent Substitution*. DE-AC07-76ID01570, U.S. Department of Energy and U.S. Air Force, Phoenix, Arizona. pp. 53-60.

## Ice Crystal Blasting

The Canadian Navy studied the use of ice crystals to remove coatings from the interiors of submarines (Larson, 1990). Preliminary testing on aircraft indicate very low stripping rates (Pauli, 1993). No active development programs were identified by this literature review. The ice crystals are used as an air-propelled blasting medium to remove coating. Because the ice crystals melt and evaporate, separation of the coating residue is simple and the waste volume is small. Ice crystal coating removal is reported to be compatible with aluminum and composite substrates.

Ice blasting uses ice crystals formed from tap water as the coating removal media. Ice crystal production equipment forms crystals of controlled size and density to ensure reliable coating removal. A typical hand-held blasting system uses about 280 scfm supply air at 200 psig to propel the ice particles. Ice crystal use rate is about 200 lb per hour.

Ice crystal blasting has been employed commercially in the United States to clean metals (stainless steels, aluminum, lead), rubber, concrete, and plastic surfaces in the nuclear industry. Oak Ridge National Laboratory and Martin Marietta have used ice blasting to decontaminate hand tools, equipment, lead bricks, hot cell walls, and other surfaces in different Oak Ridge facilities. Similar applications have been reported at the Wolf Creek and Oconee nuclear reactor plants (Apple and Jahn-Keith, 1993).

---

## References

Apple, F. C., and L. Jahn-Keith. 1993. "Ice Blasting Flushes as it Scrubs." *Nuclear Engineering International*, August.

Larson, N. 1990. "Low Toxicity Paint Stripping of Aluminum and Composite Substrates." *First Annual*

*International Workshop on Solvent Substitution*. DE-AC07-76ID01570, U.S. Department of Energy and U.S. Air Force, Phoenix, Arizona. pp. 53-60.

Pauli, R. 1993. "Dry Media Paint Stripping — Eight Years Later." In: *Proceedings of the 1993 DOD/Industry Advanced Coatings Removal Conference*, Phoenix, Arizona. pp. 220-248.

## SECTION 4 POLLUTION PREVENTION STRATEGY

Using solvent-based methods for coating removal causes release to all three environmental media: air, land, and water. Both the solvent and the removed coating materials may cause environmental concerns. The solvents used in conventional stripper formulations are hazardous and toxic. The removed coating debris also may contain resins or pigments that can cause problems for the environment or worker safety. Volatile organic vapors will enter the air due to the volatility of the stripper components. Removing the stripper and softened coating generates sludge containing a mixture of solvents and coating solids including resins and inorganic pigments. Often the stripped part is rinsed with water to remove remaining traces of stripper and coating. The poststripping rinse generates wastewater containing solvents and coating solids.

*Consumers must increasingly restrict methylene chloride use, limit emissions, and reduce exposure of workers to methylene chloride. Demand for methylene chloride declined 15% in 1991, reflecting health concerns and a weak economy.*

These multimedia releases are monitored and controlled under a diversity of laws and regulations. The main federal environmental regulations influencing selection of cleaner coating removal technology decisions are the Clean Air Act Amendments (CAAA), the Resource Conservation and Recovery Act (RCRA), the Right to Know provisions of the Superfund Amendment and Reauthorization Act (SARA), and the emphasis on eliminating pollution at the source in the Pollution Prevention Act. Solvent strippers also increase the potential workplace exposures to VOCs regulated under OSHA. There are a wide variety of state and local limits on VOC, hazardous, and aqueous wastes that also are of concern.

Title III of the CAAA requires adoption of Maximum Achievable Control Technologies (MACT) for control of 189 HAPs. Both paint stripper users and coating industries are considered major sources of HAPs and are subject to MACT standards. The coating industries

may use paint removal technologies either to remove unsatisfactory coatings or to clean paint line equipment. MACT standards may be developed for coating removal specific to the needs and attributes of the specific industry.

The requirements for cradle-to-grave management for solvent waste established by RCRA create several incentives to seek solvent-free alternatives. Disposal of RCRA wastes is costly and carries continued liability. RCRA also requires the waste generator to maintain a waste minimization program. Converting all possible plant applications to a coating removal technology that eliminates or reduces solvent use helps to demonstrate an effort to minimize hazardous waste.

Since 1988, manufacturing facilities have been reporting emissions of more than 300 chemicals or chemical categories. The reporting requirements are established under Title III of SARA. The toxic chemical release reporting is usually referred to as the Toxics Release Inventory (TRI). The reporting rule requires annual data on direct releases to all environmental media. Facilities meeting the following conditions must file TRI data:

- An SIC code in the range of 20 to 39
- 10 or more employees
- Manufacture or processing of more than 25,000 pounds or use of more than 10,000 pounds of a chemical on the TRI list.

*The Pollution Prevention Act of 1990 required expanded reporting of waste reduction activities.*

The reporting requirements were expanded to include data on recycling as required by the Pollution Prevention Act. The effort required to track and report chemical usage is significant. For plants that meet the reporting threshold, reducing chemical use below the threshold eliminates the requirement to prepare a report for the chemical. Methylene chloride is one of the TRI chemicals, so reducing or eliminating its use



will eliminate the need to complete one TRI reporting form.

The TRI data also form the basis for tracking the voluntary reduction of 17 priority toxic chemicals identified in the 33/50 Program of voluntary pollutant reductions. Methylene chloride is one of the priority toxic chemicals identified by the EPA Administrator in the 33/50 Program. Switching from solvent stripping to a cleaner stripping technology will assist in meeting the reduction goal.

The organic solvents in stripper formulations result in sufficient vapor concentrations to cause concern for workers in the area. Some of the health- and safety-related data for methylene chloride are shown in Table 5. NIOSH recommends that occupational exposure to carcinogens be limited to the lowest feasible concentration.

## References

American Conference of Governmental Industrial Hygienists. 1992. *1992-1993 Threshold Limit Values for Chemical Substances and Physical Agents and Biological Exposure Indices*. ACGIH, Cincinnati, Ohio.

National Institute for Occupational Safety and Health. 1992. *NIOSH Pocket Guide to Chemical Hazards*. U.S. Department of Health and Human Services, NIOSH, Washington, D.C.

**Table 5. Health, Physical, and Chemical Data for Methylene Chloride**

Property	Value
CAS Number	75-09-2
OSHA PEL	500 ppm <sup>(a)</sup>
OSHA Ceiling	1000 ppm (2000 ppm with 5-minute maximum peak in any 2-hour period)
NIOSH REL	"Reduce exposure to lowest feasible concentration"
NIOSH IDLH	5000 ppm
NIOSH Occupational Carcinogen	Yes
ACGIH TLV	50 ppm
ACGIH Designation	A2 (suspected human carcinogen)
Molecular Formula	C <sub>2</sub> H <sub>2</sub> Cl <sub>2</sub>
Molecular Weight	84.9 g/mol
Boiling Temperature	104°F
Freezing Temperature	-139°F
Solubility in Water	2%
Specific Gravity (@ 68°F)	1.33 g/cc
Viscosity (@ 68°F)	0.44 cp
Vapor Pressure (@ 68°F)	350 mmHg
Flash Point	None (designated combustible liquid)
Flammability Limit in Air: UEL	22%
Flammability Limit in Air: LEL	14%
Kauri Butanol Value	132

Sources: ACGIH, 1992; NIOSH, 1990.

Note: CAS = Chemical Abstract Services; PEL = permissible exposure limit; REL = Recommended Exposure Limit; IDLH = immediately dangerous to life and health; TLV = threshold limit value; UEL = upper explosive limit; LEL = lower explosive limit.

(a) OSHA is expected to lower the PEL to 25 ppm or lower according to a proposed rule.

---

## SECTION 5 CLEANER TECHNOLOGY TRANSFER CONSIDERATIONS

### Introduction

The conventional solvent stripping technologies are becoming increasingly unfavorable due to environmental pressure. The solvent technologies were popular because they were proven for removing essentially all paints and similar organic coatings from most metal and composite surfaces. Individual cleaner technologies cannot encompass the full range of coating and substrates that the solvent strippers processed. However with the variety of technologies available, there usually are one or more cleaner alternatives that will effectively fit a particular application.

*U.S. demand for methylene chloride is expected to decline by at least 3%/yr for the next several years in response to regulatory pressures. OSHA's proposed PEL revision could require use of the more costly substitutes in paint removal applications.*

Preliminary indications are that the MACT standards for coating removal will limit application of HAP-containing solvents. Most of the paint stripping MACT standards are in the early stages of development. The aerospace industry MACT standard is maturing, however. The expected proposed standard will require virtual elimination of hazardous air pollutants for aircraft depainting. An exemption of about 20 gallons of HAP solvent for removable parts, such as composite radar domes, will be allowed (Boothe, 1993). The elimination of HAPs may be achieved by substitution of a chemical stripper that does not contain HAPs or by switching to a technology that eliminates use of solvents containing HAPs.

As described above, a number of cleaner technologies for coating removal are rapidly entering commercialization. There are, however, many questions to answer before transferring an innovative technology to a specific plant. Many promising innovative technologies are convincingly demonstrated in the laboratory but require site-specific evaluation and testing to gain acceptance in commercial practice. The hurdles

between laboratory concept and field application are (Schmitz, 1992):

- Demonstrating feasibility
- Ensuring environmental compliance
- Ensuring worker safety
- Obtaining certification/warranty approvals from the maker of the equipment being stripped (aircraft) or the end user of the product (commercial goods)
- Obtaining capital approval
- Analyzing life-cycle costs
- Integrating the new system into the existing processes
- Getting worker acceptance.

*Finding the right alternative takes study and field testing.*

Finding the right stripping technology and transferring to shop use can be a challenge. The characteristics of an ideal stripping method include (Bell, 1993):

- Effectively removes the required coating
- Complies with VOC regulations and MACT standards
- Economically viable
- Minimizes capital outlay
- Is compatible with existing facilities
- Minimizes waste/effluent
- Minimizes worker hazards
- Is simple to operate
- Gives controlled stripping action
- Does not damage substrate.

No single one of the cleaner technologies will fit the requirements of all applications. However, many of the technologies are suitable substitutes for solvent stripping in specific applications. This document alerts the user to potential alternatives and helps to perform a preliminary evaluation. A few major items are discussed below to help organize the search for candidates and plan the on-site tests. However, when

selecting a coating removal technology, there is no substitute for site-specific knowledge and on-site study and testing.

## Coating Properties

**Coating type:** Tough epoxy or elastomeric coatings require aggressive abrasive action. Aggressive PMB and bicarbonate blasting systems are possible approaches for tough coatings.

**Coating thickness:** Coatings range from less than 1 mil to thermoplastic powder coatings several mils thick. Even thicker coatings are encountered on painting line apparatus. Thick coatings generally are difficult to remove with impact/abrasive systems such as PMB or wheat starch blasting. However, medium-pressure water systems, with or without bicarbonate addition, have been successful in removing thick, multilayer coatings. Burnoff ovens, molten salt baths, fluidized beds, and cryogenic N<sub>2</sub> generally provide rapid removal of thick coatings.

**Chlorocarbon and fluorocarbon films:** Burnoff technologies will generate hydrochloric or hydrofluoric acid when used to remove chlorocarbon or fluorocarbon coatings. PVC can be stripped by thermal systems if special offgas treatment systems are provided to scrub out the HCl. Fluorinated films (Teflon™) should not be stripped with burnoff technologies.

## Part and Substrate Properties

**Area to be stripped:** If the area to be stripped is large, a faster removal system is desirable. The cleaner technologies with higher removal rate potential and the ability to handle large parts include PMB, bicarbonate blasting, and medium- and high-pressure water blasting. Also, a large volume of large-area parts may support the capital investment required for a robotic or mechanized system.

**Size of part:** Small parts may be stripped in cabinet or confined systems. These systems include PMB cabinet blasters, cryogenic N<sub>2</sub> systems, burnoff ovens, molten salt baths, and fluidized beds. For parts with one dimension over about 10 feet, open-area systems such as the various media blasting systems typically are more applicable.

**Substrate abrasion resistance:** For less sensitive substrates, more aggressive stripping media are acceptable. Harder, more aggressive plastic media, high- or medium-pressure water blasting, or aggressive sodium bicarbonate blasting can give good removal rates. For more sensitive substrates, options to consider are softer plastic media, wheat starch, CO<sub>2</sub>, high-

or medium-pressure water blasting, or sodium bicarbonate blasting.

**Thickness of substrate:** With a thin, soft sheeting (e.g., skin of commercial aircraft), substrate deformation can be a problem. The more aggressive bead-blasting technologies may deform thinner materials. Development is continuing to determine the best condition for acceptable strip rates for various methods with minimal substrate damage or deformation.

*Testing on small areas may be done to determine potential damage. Pressures can be lowered to reduce the possibility of damage. However, lowered pressures can reduce stripping effectiveness.*

**Poststripping inspection requirements:** In some applications, particularly aircraft parts, coating removal is performed to allow inspection of the substrate. One major concern is hairline fatigue cracks. The more aggressive bead blasting technologies may peen cracks closed, thus making detection difficult. Development is continuing to determine the effects of cleaner coating removal technologies on crack closure.

**Presence and condition of substrate surface finish (primer, filler, chemical film):** In some maintenance stripping applications, only the topcoat is to be removed. Any primers, fillers, or chemical films are left intact, if possible. Controlled layer-by-layer stripping action is possible with less aggressive plastic media, wheat starch, CO<sub>2</sub>, or certain types of sodium bicarbonate blasting.

**Heat sensitivity:** High-temperature stripping systems are unsuitable for temperature-sensitive parts. For example low-melting metals such as zinc and its alloys, parts with heat tempering such as springs, or parts where critical dimensions must be maintained are not suitable for high-temperature coating removal. Pyrophoric metals such as magnesium must not be treated by thermal processes.

## Process Concerns

*Each user has individual concerns and priorities.*

**Pollution prevention:** All of the cleaner technologies eliminate use of HAP-containing solvent strippers. They produce a variety of waste streams. Technology selection depends on plant requirements and the support equipment available.

**Required throughput rates:** The cleaner technology must be able to achieve required throughput rates to be

---

acceptable. Where many small parts need to be stripped rapidly, technologies such as PMB cabinet blasters, cryogenic N<sub>2</sub> systems, burnoff ovens, fluidized beds, or molten salt baths should be considered. Systems with the potential for high throughput with larger items include PMB, bicarbonate blasting, and medium- and high-pressure water blasting.

**Coating removal quality standards:** Cleaner technologies are all capable of removing coatings. The desired end point is plant-specific and must be judged based on site-specific needs.

**Capital costs:** Obtaining the necessary capital for addition of a new system can be difficult, even if there is an eventual payback in reduced operating expenses. The most capital-intensive cleaner coating removal technologies include high-pressure water blasting and laser paint stripping due to the need for mechanized controls.

**Floor space available:** In many cases the cleaner technology will be considered as a replacement for an existing solvent stripping system. In retrofit applications, it is always desirable to avoid major facility modifications. Cleaner paint removal systems with modest space and utility support requirements include

sodium bicarbonate blasting, burnoff systems, molten salt baths, and medium-pressure water-blasting systems.

**Utilities available:** The availability of compatible support systems can be a factor in selecting a technology. If water treatment systems are available on site, systems such as bicarbonate blasting or medium- and high-pressure water blasting can be attractive. For example, high-pressure water spray is ideal for removing paint buildup from floor grates of a water-wall spray booth.

## References

- Bell, B. 1993. "A/C Paint Stripping — The Future." In: *Proceedings of the 1993 DOD/Industry Advanced Coatings Removal Conference*, Phoenix, Arizona. pp. 249-277.
- Boothe, V. 1993. (919) 541-0164. U.S. Environmental Protection Agency. Personal communication with Lawrence Smith, Battelle Memorial Institute.
- Schmitz, W. N. 1992. "New Technologies — Hurdles to Implementation." In: *Third Annual International Workshop on Solvent Substitution*, U.S. Department of Energy and U.S. Air Force, Phoenix, Arizona.

## SECTION 6 INFORMATION SOURCES

This section provides the trade associations affiliated with the technologies that have been discussed. Table 6 shows the trade associations and the technology areas they cover. Readers may contact these trade associations and request their assistance in identifying one or more companies that could provide the desired technological capabilities.

**Table 6. Trade Associations and Technology Areas**

Trade Association	Technology Areas Covered	Contact
Association for Finishing Processes of the Society of Manufacturing Engineers	Industrial finishing operations	P.O. Box 930, One SME Drive Dearborn, MI 48121 tel. (313) 271-1500
Federated Societies for Coating Technology	Decorative and protective paints	492 Norristown Road / Bluebell, PA 19422 tel. (215) 940-0777
International Air Transport Association	Aircraft transportation issues including depainting	IATA Building / 2000 Peel Street Montreal, PQ / Canada H3A 2R4 (514) 844-6311
International Organization for Standardization	Technical Committee 20/Working Group 8 is working on aircraft depainting standards	1, rue de Varembe / Case Postale 56 CH-1121 Geneva 20 / SWITZERLAND tel. 22 7490111
National Paint & Coatings Association	Paints and chemical coatings, related raw materials, and equipment	1500 Rhode Island Avenue, N.W. Washington, DC 20005 tel. (202) 462-6272
Powder Coating Institute	Powder coating materials and equipment	1800 Diagonal Rd., Ste. 370 Alexandria, VA 22314 tel. (703) 684-1770
Radtech International	Radiation-curable paints and coatings	60 Revere Drive, Ste. 500 Northbrook, IL 60062 tel. (708) 480-9576
SAE	Aeronautical Materials Specification Committee J is working on implementing SAE AMS documents as replacements for military specifications replacing HAPs	400 Commonwealth Drive Warrendale, PA 15096-0001 (412) 776-4841

United States  
Environmental Protection Agency  
Center for Environmental Research Information  
Cincinnati, OH 45268

Official Business  
Penalty for Private Use  
\$300

EPA/625/R-93/015

Please make all necessary changes on the below label,  
detach or copy, and return to the address in the upper  
left-hand corner.

If you do not wish to receive these reports CHECK HERE ;  
detach, or copy this cover, and return to the address in the  
upper left-hand corner.

BULK RATE  
POSTAGE & FEES PAID  
EPA  
PERMIT No. G-35