

EPA 440/1-75/038-a  
GROUP I, PHASE II

**Development Document for Interim  
Final Effluent Limitations Guidelines  
and Proposed New Source  
Performance Standards  
for the**

**ELECTROLYTIC FERROALLOYS**

**Segment of the  
FERROALLOY MANUFACTURING  
Point Source Category**



**UNITED STATES ENVIRONMENTAL PROTECTION AGENCY  
FEBRUARY 1975**

DEVELOPMENT DOCUMENT  
for  
INTERIM FINAL EFFLUENT LIMITATIONS GUIDELINES  
and  
PROPOSED NEW SOURCE PERFORMANCE STANDARDS  
for the  
ELECTROLYTIC FERROALLOYS SEGMENT  
of the  
FERROALLOYS MANUFACTURING  
POINT SOURCE CATEGORY

Russell E. Train  
Administrator

James L. Agee  
Assistant Administrator for  
Water and Hazardous Materials



Allen Cywin  
Director, Effluent Guidelines Division

Patricia W. Diercks  
Project Officer

February, 1975

Effluent Guidelines Division  
U.S. Environmental Protection Agency  
Washington, D.C.

## ABSTRACT

For the purpose of establishing effluent limitations guidelines and standards of performance for the electrolytic ferroalloys segment of the ferroalloy industry, the industry has been categorized on the basis of product produced and wastewater constituents as follows:

- I. Electrolytic Manganese Products
- II. Electrolytic Chromium

The effluent limitations to be achieved by July 1, 1977 are based upon the pollution reduction attainable using those treatment technologies as presently practiced by the average of the best plants in these categories, unless present technology is uniformly inadequate within a category. The technologies are for the most part based upon the use of "end-of-pipe" treatment and generally once-through water usage.

The effluent limitations to be achieved by July 1, 1983 are based upon the pollution reduction attainable using those control and treatment technologies as presently practiced by the best plant in the category, or readily transferrable from one industry process to another.

The new source performance standards are based upon the best available demonstrated control technology, process, operating methods, or other alternatives which are applicable to new sources.

Costs are given for the various levels of treatment identified for each category and for the attainment of the suggested effluent guidelines and new source performance standards.

Page Intentionally Blank

## CONTENTS

<u>Section</u>		<u>Page</u>
I	Conclusions	1
II	Recommendations	3
III	Introduction	7
IV	Industry Categorization	15
V	Waste Characterization	19
VI	Selection of Pollutant Parameters	27
VII	Control and Treatment Technology	35
VIII	Cost, Energy and Non-Water Quality Aspects	43
IX	Best Practicable Control Technology Currently Available, Guidelines and Limitations	51
X	Best Available Technology Economically Achievable, Guidelines and Limitations	55
XI	New Source Performance Standards and Pretreatment Standards	59
XII	Acknowledgements	63
XIII	References	65
XIV	Glossary	67

## FIGURES

<u>No.</u>		<u>Page</u>
Figure 1	Electrolytic Manganese Flowsheet	10
Figure 2	Electrolytic Chromium Flow Sheet	13
Figure 3	Plant A - Water and Wastewater Systems	21
Figure 4	Plant B - Water and Wastewater Systems	22
Figure 5	Plant C - Water and Wastewater Systems	23
Figure 6	Electrolytic Manganese Products Treatment System	41
Figure 7	Electrolytic Chromium Treatment System	42
Table 1	Wastewater Treatment Level Costs	44
Figure 8	Cost of Treatment vs. Effluent Reduction Electrolytic Manganese Products	49
Figure 9	Cost of Treatment vs. Effluent Reduction Electrolytic Chromium	50
Table 2	Conversion Factors	68

## SECTION I

### CONCLUSIONS

For the purpose of establishing effluent limitations guidelines and standards of performance for the electrolytic processes segment of the ferroalloys industry, the industry segment has categorized on the basis of product produced and wastewater constituents. The categories are as follows:

- I. Electrolytic Manganese Products
- II. Electrolytic Chromium

Other factors, such as age, size of plant, geographic location and water uses do not justify segmentation of the industry into any further subcategories for the purpose of establishing effluent limitations and standards of performance. Similarities in waste loads and available treatment and control technologies within the categories further substantiate this. The guidelines for application of the effluent limitations and standards of performance to specific plants take into account the mix of processes and water uses possible in a single plant which directly influence the quantitative polluttional load.

Page Intentionally Blank



## SECTION II

### RECOMMENDATIONS

It is recommended that the effluent limitations guidelines and new source performance standards be adopted as suggested herein for the electrolytic ferroalloys segment of the ferroalloy industry. These guidelines and performance standards have been developed on the basis of an intensive study of the industry, including plant surveys, and are believed to be reasonable and attainable from the standpoints of both engineering and economic feasibility.

The application of these guidelines and performance standards to specific plants is intended to be on the basis of a "building block" approach to define the effluent limits from the plant as a whole. Consider, for example, a plant having processes in one or more categories. The total effluent limitation for the plant would be determined by multiplying the allowable unit loads by the total production rate in each category and adding the loads from each category. It is recommended that this method of application of the guidelines and performance standards be used.

The effluent limitations guidelines, i.e., for the best practicable control technology currently available and for the best available technology economically achievable, are intended to be based upon measurements taken at the outlet of the last wastewater treatment process unit.

The best practicable control technology currently available for existing point sources is as follows, by category:

- I Physical/chemical treatment to remove or destroy suspended solids and potentially harmful or toxic pollutants, with recirculation of the strong wastewater stream from manganese production.
- II Physical/chemical treatment to remove or destroy suspended solids and potentially harmful or toxic pollutants.

The effluent limitations are based on achieving by July 1, 1977 at least the pollution reduction attainable using these treatment technologies. The above technologies are generally based upon the use of end-of-pipe treatment and once-through water usage. The 30-day average effluent limitations corresponding to the best practicable control technology currently available are as follow, by category,

where all quantities are in kilograms per metric ton of product (pounds per thousand pounds), except for pH.

	TSS	Mn	Cr	NH <sub>3</sub> -N	pH
Category I-Mn	3.389	1.356	--	20.334	6.0 - 9.0
Category I-MnO <sub>2</sub>	0.881	0.352	--	5.287	6.0 - 9.0
Category II	2.638	1.055	0.106	5.276	6.0 - 9.0

The best available technology economically achievable for existing point sources is as follows, by category:

- I Partial recycle of water, with treatment for removal of suspended solids and potentially harmful or toxic pollutants by physical/chemical treatment.
- II Partial recycle of water, with treatment for removal of suspended solids and potentially harmful or toxic pollutants by physical/chemical treatment.

The effluent limitations are based on achieving by July 1, 1983, at least the pollution reduction attainable using these control and treatment technologies as presently practiced by the best plant in each category and using transfer of technology where the best plant in the category was felt to be insufficient. The 30-day average effluent limitations corresponding to the best available technology economically achievable for existing point sources are as follows, by category, where all quantities are in kilograms per metric ton of product (pounds per thousand pounds), except for pH.

	TSS	Mn	Cr	NH <sub>3</sub> -N	pH
Category I-Mn	1.695	0.339		3.389	6.0 - 9.0
Category I-MnO <sub>2</sub>	0.441	0.088	--	0.881	6.0 - 9.0
Category II	1.324	0.265	0.027	2.649	6.0 - 9.0

The new source performance standards are based upon the best available demonstrated control technology, process, operating methods, or other alternatives which are applicable to new sources. The best available demonstrated control technology for new sources is as follows, by category:

- I Limitation of the quantity of wastewater by in-plant recirculation, mechanical transport of filter residues, and treatment for removal of suspended solids and

potentially harmful or toxic pollutants by physical/chemical treatment for electrolytic manganese. For manganese dioxide, same as BATEA.

II Limitation of the quantity of wastewater by in-plant recirculation, transport of filter residues, and treatment for removal of suspended solids and potentially harmful or toxic pollutants by physical/chemical treatment.

The new source limitations are as follows, by category, where all quantities except for pH are in kilograms per metric ton of product (pounds per thousand pounds of product):

	TSS	Mn	Cr	NH <sub>3</sub> -N	pH
Category I-Mn	0.740	0.148	--	1.481	6.0 - 9.0
Category I-MnO <sub>2</sub>	0.441	0.088	--	0.881	6.0 - 9.0
Category II	0.417	0.083	0.008	0.834	6.0 - 9.0

Page Intentionally Blank

## SECTION III

### INTRODUCTION

The Federal Water Pollution Control Act Amendments of 1972 (the "Act") requires the United States Environmental Protection Agency to establish effluent limitations which must be achieved by point sources of discharge into the navigable waters of the United States. Section 301 of the Act requires the achievement by July 1, 1977, of effluent limitations which require the application of the "best practicable control technology currently available," and the achievement by July 1, 1983, of effluent limitations which require the application of the "best available technology economically achievable."

The Administrator is required by Section 304 (b) to promulgate regulations providing guidelines for the effluent limitations required to be achieved under Section 301 of the Act. These regulations are to identify in terms of amounts of constituents and chemical, physical, and biological characteristics of pollutants, the degree of effluent reduction attainable through the application of the best practicable control technology currently available and best available technology economically achievable. The regulations must also specify factors to be taken into account in identifying the two statutory technology levels and in determining the control measures and practices which are to be applicable to point sources within given industrial categories or classes to which the effluent limitations apply.

In addition to his responsibilities under Section 301 and 304 of the Act, the Administrator is required by Section 306 to promulgate standards of performance for new sources. These standards are to reflect the greatest degree of effluent reduction which the Administrator determines to be achievable through the application of the "best available demonstrated control technology, processes, operating methods, or other alternatives, including, where practicable, a standard permitting no discharge of pollutants."

The Office of Water and Hazardous Materials of the Environmental Protection Agency has been given the responsibility by the Administrator for the development of effluent limitation guidelines and new source performance standards as required by the Act. The Act requires the guidelines and standards to be developed within very strict

deadlines and for a broad range of industries. Effluent limitations guidelines under Section 301 and 304 of the Act and standards of performance for new sources under Section 306 of the Act will be developed for 27 industrial categories. Moreover, each of these industrial categories probably will require further subcategorization in order to provide standards that are meaningful.

In order to promulgate the required guidelines and standards, it is first necessary to (a) categorize each industry; (b) characterize the waste resulting from discharges within industrial categories and subcategories; and (c) identify the range of control and treatment technology within each industrial category and subcategory. Such technology will then be evaluated in order to determine what constitutes the "best practicable control technology currently available," what is the "best available technology economically achievable" and, for new sources, what is the "best available demonstrated control technology".

In identifying the technologies to be applied under Section 301, Section 304(b) of the Act requires that the cost of application of such technologies be considered, as well as the non-water quality environmental impact (including energy requirements) resulting from the application of such technologies. It is imperative that the effluent limitations and standards to be promulgated by the Administrator be supported by adequate, verifiable data and that there be a sound rationale for the judgements made. Such data must be readily identifiable and available and such rationale must be clearly set forth in the documentation supporting the regulations.

#### Electrolytic Processes

Manganese metal and chromium metal are produced electrolytically by a method developed just before World War II. Simple ions of the metal contained in an electrolyte are plated on cathodes by low-voltage direct current to give free metal atoms. When the buildup on the cathode becomes sufficient, the plates are withdrawn from the electrolytic cells and the deposited metal is removed. Manganese dioxide is plated anodically.

The electrolytic process for producing nearly pure metals is a largely chemical operation as far as the preparation of electrolytes is concerned. The source of the feed materials are ores, ferroalloy slag, or ferroalloys produced in electric furnaces. The metal deposition is made in a number

of cells with multiple plates, connected in parallel electrical circuits.

### Electrolytic Manganese

Manganese may be produced by the electrolysis of an electrolyte extracted from manganese ore or manganese-bearing ferroalloy slag. Manganese ores contain close to 50 percent manganese. Slag from an electric furnace producing ferromanganese normally contains 10 percent manganese but this percentage can be increased by adjusting the furnace operating conditions. Both have proven to be suitable raw materials for the electrolytic process. A flow sheet of the process for the preparation of electrolytic manganese is given in Figure 1. The process can be considered primarily a four-step operation: 1) roasting the ore, 2) leaching the roasted ore, 3) purifying the leach liquor, and 4) electrolysis.

(1) Roasting. The ore is roasted to convert the manganese oxides present to  $MnO$ , while the iron is left as  $Fe_3O_4$  which is less soluble than the lower oxides of iron in the sulfuric acid used for leaching.

(2) Leaching. The ground and roasted ore is leached with recycled anolyte from the electrolytic cell, which is principally ammonium sulfate with some sulfuric acid and manganous sulfate. The concentration of the leach is adjusted by addition of ammonium sulfate and sulfuric acid. Overall extraction of manganese from the roasted ore is 98-99 percent. On neutralization, iron and aluminum hydroxides are precipitated and take down with them most of the molybdenum, arsenic and silica. The solution is then clarified and filtered.

(3) Purifying the leach liquor. The neutral leach liquor contains some iron, arsenic, copper, zinc, lead, nickel, cobalt and molybdenum, which must be removed before electrolysis. Removal is accomplished by treatment with hydrogen sulphide gas or ammonium sulphide and filtration of the liquor to remove the sulphides. A small amount of manganese is lost in this step.

(4) Electrolysis. The purified solution for electrolysis enters the cathode compartment, where manganese is plated on the cathode, flows through the diaphragm into the anode compartment from which it is discharged. It may then be recycled for leaching of the ore or slag.

Figure 1.  
ELECTROLYTIC MANGANESE FLOWSHEET

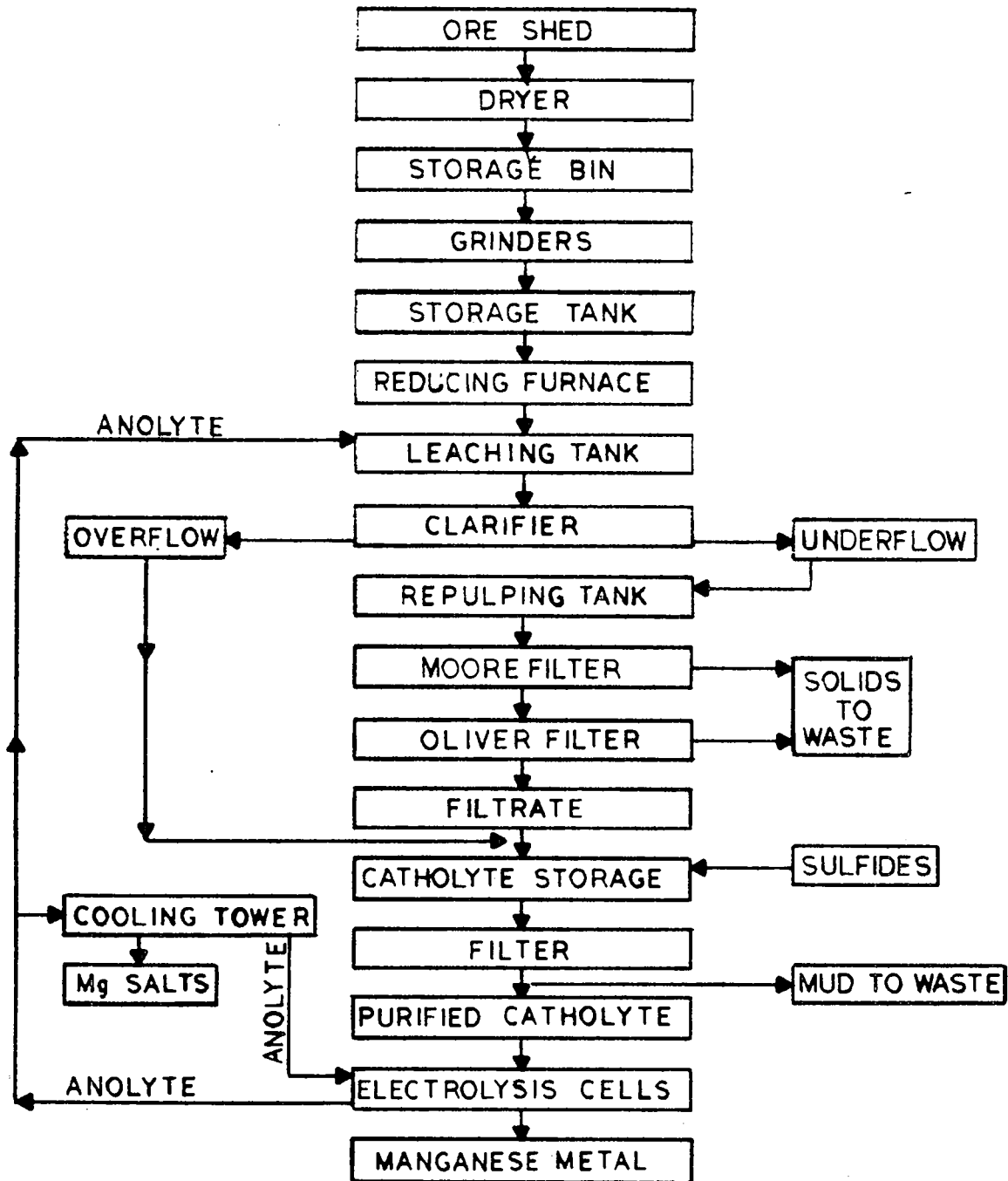



## Manganese Dioxide

One process for the production of manganese dioxide is the roasting of pyrolusite ore. It may also be prepared synthetically by electrolysis of manganese sulfate in a sulfuric acid solution. Only the latter method will be considered further herein.

The ore is crushed, ground, mixed with Bunker 'C' oil and roasted, which converts higher oxides to soluble MnO. In a leaching tank, spent electrolyte solution and make-up sulfuric acid leach the roasted ore. Insoluble sludge separates out from the leach solution on filters. The crude leach solution is next treated with barium sulfide to remove cobalt and nickel impurities as insoluble sulfides. CaO is added for neutralization and the sulfide sludge is removed.

Part of the sludge recycles back to the sulfide treatment tank to recover any manganese that may have precipitated with the impurities. Iron is removed (along with sulfur, arsenic, and organics) by air oxidation and the iron sludge is filtered out. The filtrate is used as the feed solution for the electrolytic cells.

MnO<sub>2</sub> deposits on anodes in the electrolytic cells, and after separation from the anodes, the MnO<sub>2</sub> is ground and the fine material is washed in a thickening tank, filtered and dried. The manganese dioxide is then ready for packing and shipment.

## Electrolytic Chromium

The most readily available and cheapest source for electrolytic chromium, free from many extraneous elements, is high carbon ferrochromium produced in the electric furnace. This alloy is readily soluble in sulfuric acid.

Ferrochromium is fed to a leach tank where it is dissolved in a mixture of reduced anolyte, chromium alum mother liquor and make-up sulfuric acid. During the reaction a large volume of hydrogen is liberated and a ventilating system, necessary to maintain hydrogen concentration below explosive limits, exhausts the gases to a scrubber.

After leaching, the slurry is fed into a holding tank where cold mother liquor, coming from the ferrous ammonium sulfate crystallization, is added to cool the batch. Undissolved solids are separated from the solution and this residue is washed with water and discarded. The solution resulting from washing the leach residue is used to dissolve the crude

iron sulfate. Ammonium sulfate is added to this solution and ferrous ammonium sulfate crystals then separated on a vacuum filter and dried in a rotary drier. This can be sold as a fertilizer for its ammonia content. The filtrate is advanced to a conditioning tank, where the chromium is converted to the non-alum-forming modification by holding at elevated temperatures for several hours. The conditioned liquor is then pumped into a crystallizer and the temperature is reduced. Crude iron sulfate crystals which are formed during this cooling period are separated from the mother liquor on a vacuum filter.

The conditioned liquor is clarified and sent to the aging circuit. About 80 percent of the chromium is stripped as alum from the aging circuit. The crystal slurry is filtered and washed; the filtrate is pumped to the leach circuit and the washed chromium-alum crystals are dissolved in hot water to produce cell feed. Cell feed is supplied continuously to the operating cells where it is mixed with a stream of circulating catholyte. Excess catholyte is withdrawn from the circulating stream and pumped back into the aging circuit. Anolyte is treated with sulfur dioxide to reduce the chromic acid to trivalent chromium and then returned to the start of the ferrochromium leaching circuit. The electrolytic cells are covered and are strongly ventilated to reduce the ambient hydrogen and hexavalent chromium concentrations in the cell room.

Cathodes are withdrawn from the cells periodically and the plated metal is stripped, crushed and washed with hot water in a classifier to remove soluble salts.

The process flow diagram for the production of electrolytic chromium is shown in Figure 2.

Figure 2  
FLOW SHEET FOR ELECTROLYTIC CHROMIUM

13

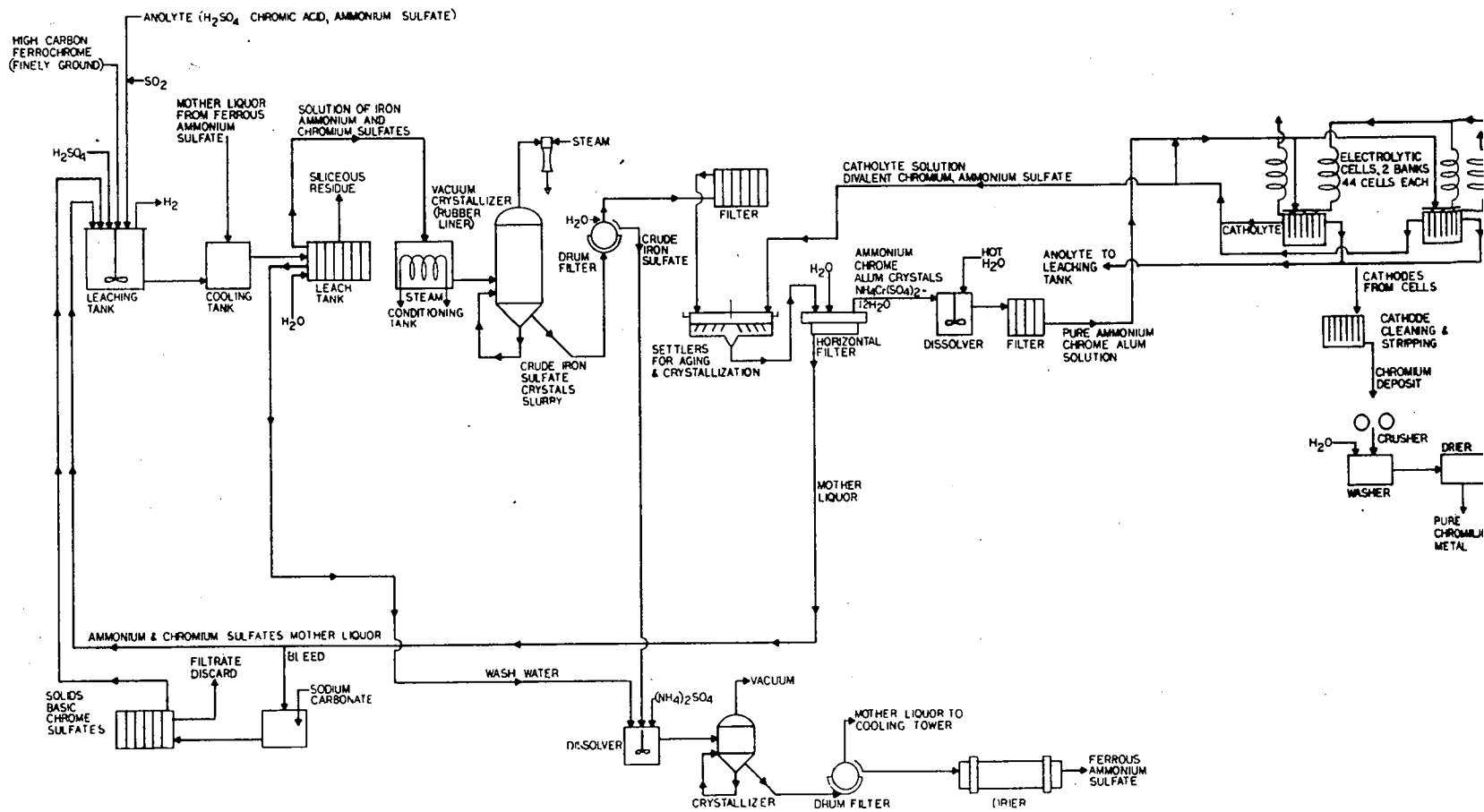

Page Intentionally Blank

## SECTION IV

### INDUSTRY CATEGORIZATION

The purpose of the effluent limitations can be realized only by categorizing the industry into the minimum number of groups for which separate effluent limitations and new source performance standards are reasonably required and must be developed. The categorization here is believed to be that minimum, i.e., the least number of groups having significantly different water pollution potentials and treatment problems. The categorization is as follows:

- I. Electrolytic manganese products
- II. Electrolytic chromium

In developing this categorization, consideration was given to the following factors as possibly providing bases for categorization:

- 1. Raw Materials
- 2. Product Produced
- 3. Size and Age of Facilities
- 4. Waste water Constituents
- 5. Treatability of Wastes
- 6. Production processes
- 7. Water Uses

#### Raw Materials

The raw materials used for electrolytic ferroalloys production may be either ores, ferroalloys or slag from electric furnace production of ferroalloys. The type of raw material used, of course, varies with the type of end product desired. High carbon ferrochromium is used exclusively for electrolytic chromium, while electrolytic manganese might be made with either manganese ore or slag from the production of ferromanganese. Manganese dioxide is made from manganese-bearing ore, exclusively. Differentiation on the basis of raw materials as between products is to some extent inherent in the chosen categorization, but is only a very secondary basis.

#### Product Produced

Product groupings were judged to provide the best basis for categorization, primarily because waste water constituents vary by product. Although manganese is found to some extent

in the wastewater from chromium production, no (or miniscule) quantities of chromium are found in manganese production wastewaters. Additionally, the weak wastewater stream from manganese production bears a marked degree of similarity to the wastewater stream from manganese dioxide manufacture.

#### Size and Age of Facilities

Size and age of facilities do not appear to provide any basis for categorization. These processes are essentially modular in nature, and the manganese plants, in particular, are all approximately equal in size. Plant ages will, of course, affect the ease with which changes can be made in processing and treatment systems and will affect the costs of implementation, since the newer plants have taken more pains to recycle waters within the plant and reduce effluent volumes. To some extent, this is an economy measure, as the price of the raw materials have increased markedly in the past few years. An increase in raw material costs makes recirculation more attractive, particularly when 10 to 20% of the metal value in the raw material is being lost in the discharge. However, although the newer plants will incur lower costs to meet the guidelines than will the older plants, the total cost for pollution control for all plants will not be that disparate, since the newer plants have already spent substantial sums.

#### Waste water Constituents

Wastewater constituents and water usage rates provide the most important bases for categorization. Suspended solids is a common problem, although the quantity does differ somewhat with product. Ammonia is found in the highest concentrations in wastewaters from manganese and chromium production, although enough is present in manganese dioxide wastewaters to warrant limitations. Manganese is found in the highest concentrations in wastes from manganese and manganese dioxide production, but again, enough is found in wastewaters from chromium production to warrant limitation. Chromium, however, is only found in appreciable quantities in chromium production wastewaters--only trace amounts being present in manganese dioxide and manganese wastes. For these reasons, the categorization of this industry by product grouping was felt to be the most rational approach.

#### Treatability of Wastes

The wastes produced from the various processes may be treated by essentially similar methods and no separate basis

for categorization is found here. Of course, chromium producers have available to them the option of crystallizing ferrous ammonium sulfate, and thereby reducing the quantity of ammonia to be treated, which is not available to manganese and manganese dioxide producers. However, this slight difference is not sufficient to warrant separate categorization, but is instead a corollary reason for the subcategorization based on product groupings.

### Production Processes

The production processes are fairly similar within this segment. The process generally consists of leaching the metal from either ore or ferroalloys, various purification steps, and electrolytic deposition. Generally, there are more similarities than differences between the processes. There are some slight differences, however. The processes for production of chromium and manganese use ammonia as an integral part of the process, while that for manganese dioxide does not. Chromium and manganese are plated anodically, while manganese dioxide is plated cathodically. While there are these and other small differences, the end result, the wastewater, is more amenable to differentiation on the basis of product groupings and wastewater constituents than of production process.

### Rationale for the Segmentation of the Ferroalloys Industry

During the previous year the ferroalloys industry was categorized and limitations established for the open electric furnaces with wet air pollution control devices subcategory, the covered electric furnaces with wet air pollution control devices subcategory and the slag processing subcategory. The categories as proposed herein cannot be made to conform with the established categories for several reasons.

One of those is the differing water usage rates--the electrolytic segment consumes, generally, several times as much water as does the smelting segment. Although some of the constituents, such as suspended solids, manganese and chromium are common to both segments, cyanide and phenol are found only in the wastes from the electric furnace smelting operations, while ammonia was found only in electrolytic wastes. Additionally, water is used as an integral part of the process in the electrolytic segment, as well as for non-contact cooling. The only water uses in the smelting segment are for gas cleaning and non-contact cooling.

Page Intentionally Blank



## SECTION V

### WASTE CHARACTERIZATION

Water is used extensively in the electrolytic ferroalloys industry -- for preparing the electrolyte, washing the plated metal, filter residue transport, non-contact cooling, etc.

#### Electrolytic Manganese

There are three plants presently producing electrolytic manganese. Plant A began producing manganese about 20 years ago, Plant B about 6 years ago, and Plant C about 10 years ago. All are approximately equal in size at about 9000 kkg (10,000 tons) annual production. Both of the older plants hydraulically transport filter residues from the electrolyte preparation processes to tailings ponds. Plant B collects and hauls the filter muds. Plants B and C use ore as their feedstock, while Plant A uses slag produced during the smelting of ferromanganese in electric furnaces.

In the electrolytic manganese industry, the waste waters may be classed as either "strong" or "weak." The "strong" wastewaters contain some electrolyte and may also carry filter residues from electrolyte preparation. As a result, they may contain several thousand mg/l of suspended solids, manganese, ammonia and sulfate.

The "weak" wastewaters, however, result primarily from washdowns and other miscellaneous uses. Compared to the strong wastewaters, they are very much lower in concentration. A comparison of the strong and weak wastewaters is found below for Plants A and B.

	Strong Wastewater		Weak Wastewater	
	Plant A mg/l	Plant B mg/l	Plant A mg/l	Plant B mg/l
Suspended Solids	55,300	85	144	9
Manganese	6,700	1,061	128	21.7
Ammonia-N	4,208	3,733	148	16
Sulfate	35,524	7,100	900	73
pH	7.3	2.7	5.1	7.3
Flow (gal/ton)	3820	6000	32,500	6400

The raw waste loads for these plants are as follows, in kg/kkg (lb/1000 lb):

Parameter	Plant A			Plant B		
	'Strong'	'Weak'	Total	'Strong'	'Weak'	Total
Suspended Solids	881.1	19.5	900.6	2.13	.24	2.37
Manganese	106.8	17.4	124.2	26.55	.58	27.13
Ammonia-N	67.0	20.1	87.1	93.42	.43	93.83
Sulfate	566.0	122.0	688.0	177.68	1.95	179.63

Waste water treatment at all three plants depends highly on lagoons. Plant A discharges the strong manganese wastes with a lime slurry for neutralization into a large 30 ha (70 ac) settling lagoon. The weak wastewater, after mixing with other plant wastewaters, is also discharged into this lagoon.

Plant B discharges the strong wastewater to a large pond, where after settling and evaporation by sprays, the wastewater is recycled to the plant for use as primary washwater and other miscellaneous uses. The weak wastewaters are usually discharged directly to a stream, although a dissolved solids monitor may divert the discharge to the evaporation pond, should the dissolved solids level exceed a preset limit.

Plant C diverts their weak wastewaters into a pond. These consist mostly of washwaters from the manganese production. Prior to the pond, they are mixed with wastes from the production of other materials at the plant. The strong wastewaters (also mixed with other plant wastes) flow to another tailings pond, where after some aeration, they enter an oxidation pond, after which they join the weak wastewater mixture and are discharged.

Figures 3, 4 and 5 show the wastewater flow diagrams at Plant A, B and C.

Figure 3  
Plant A  
Water and Wastewater Systems

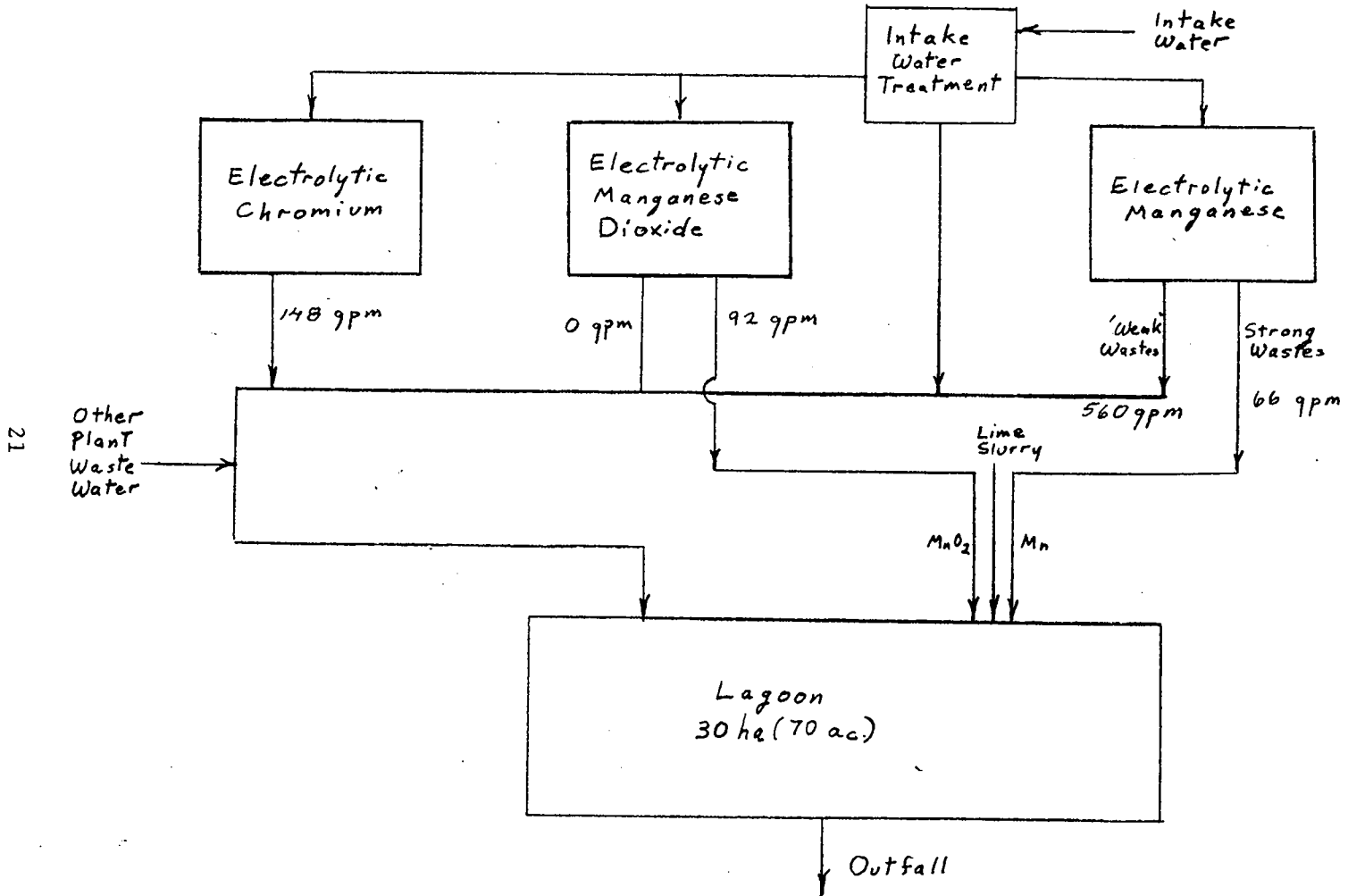

Figure 9  
Plant B  
Water and Wastewater Systems

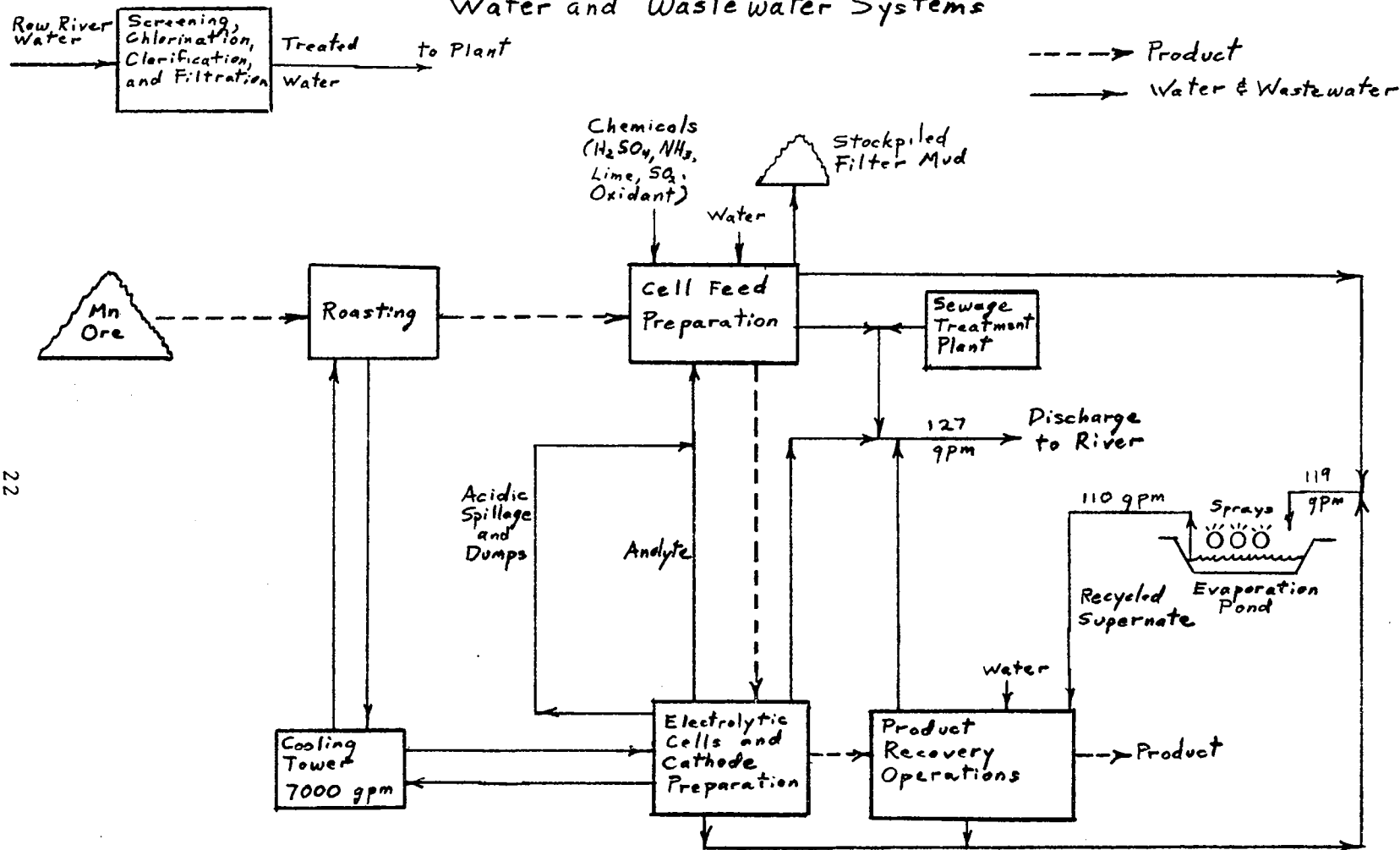
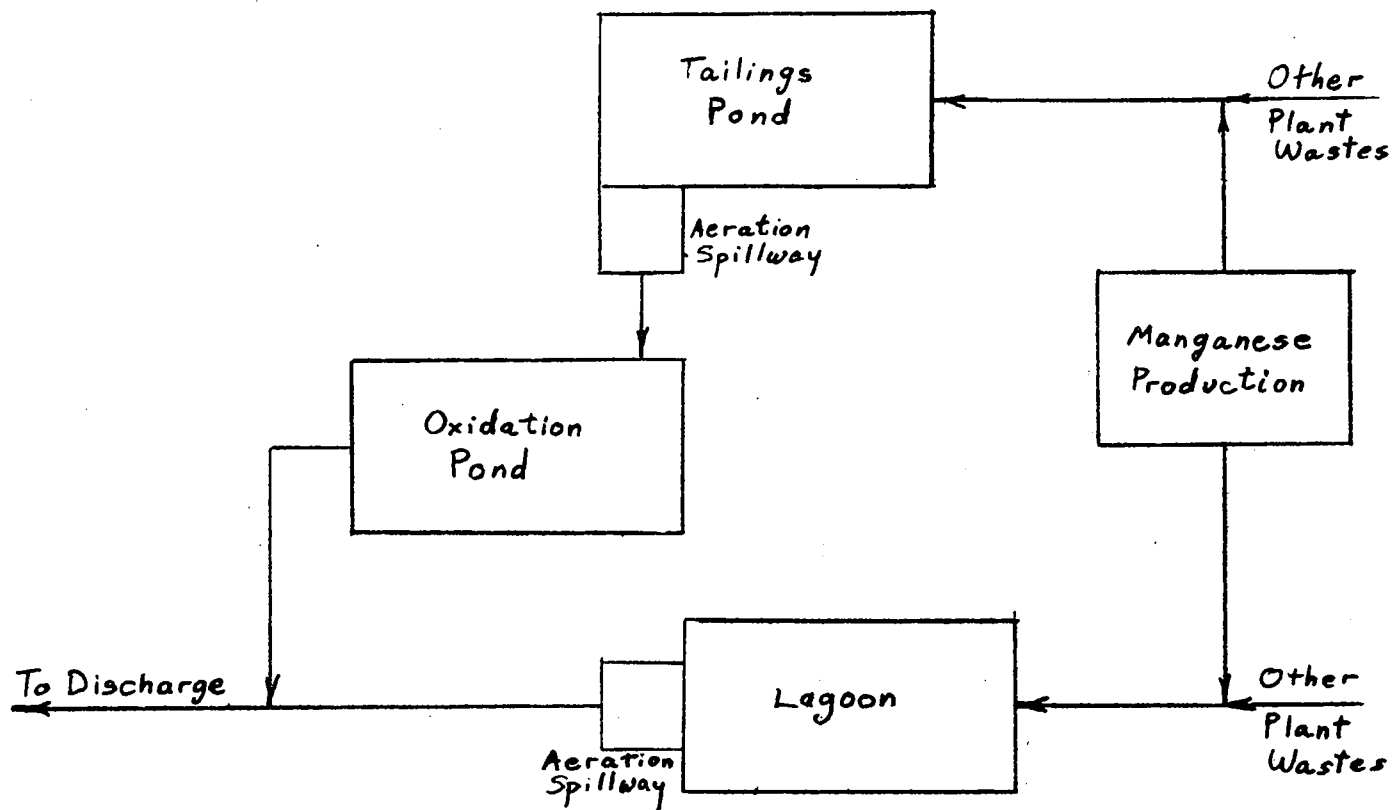

Figure 5

Plant C  
Water and Wastewater Systems



### Manganese Dioxide

The raw waste from the production of manganese dioxide at Plant A is as follows:

	Concentration (mg/l)	Raw Waste Load kg/kkg (lb/1000 lb)
Suspended Solids	22,505	770.5
Manganese	3,158	108.3
Ammonia-N	75	2.7
pH (units)	4.1	
Flow (gal/ton)		8207

Treatment of the wastewater is identical to that for the strong wastewaters from electrolytic manganese production at Plant A. This facility was installed about seven years ago.

### Electrolytic Chromium

Plant A produces this commodity, as does Plant D. Plant A's chromium facility was constructed about 20 years ago, while Plant D started operation in early 1974. The raw waste from chromium production at Plant A is as follows:

	Concentration (mg/l)	Raw Waste Load kg/kkg (lb/1000 lb)
Suspended Solids	290	30.5
Chromium	1764	186.1
Iron	4492	473.8
Manganese	52	5.5
Ammonia-N	1076	113.5
pH (units)	2.9	
Flow (gal/ton)		25,285

Plant A crystallizes and sells ferrous ammonium sulfate to a fertilizer company. During the times that the FAS cannot be sold, it is not crystallized and becomes part of the raw waste. The data reported above reflect the latter condition. Treatment at Plant A for this waste stream is identical to that for the weak electrolytic manganese wastewater.

The conventional process at Plant D is altered in that the solution from the leach filter goes first to the aging and crystallizing settlers through a cooler then to the steam conditioning tank and thence through the remainder of the process; additionally, some of the mother liquor from the horizontal filter can be returned to the steam conditioning

tank or to the leaching tank. This modification reportedly produces a better, drier crude ferrous ammonium sulfate which can be used as-is. Residue from the leach filter is trucked to storage as a damp sludge, condensate from the vacuum crystallizer is re-used, ammonium sulfate is sold or given away in the crude without recrystallization, and the filter effluents are minimal. The waste water effluent from Plant D was expected to be .06 l/sec or less (1 gpm or less) due mainly to spills and washups. All such waste waters must be pumped from the plant sumps. Treatment is lime neutralization followed by 3 settling basins in series. The batch discharge is slightly larger than expected and is equivalent to 6245 l/kg (1500 gal/ton) of product. Plant C reports only one batch discharge during the period from mid-March to mid-June of this year. Additionally, it is estimated that a thousand gallons per day was lost by solar evaporation. It is hoped that experimental work by a fertilizer company will result in the crude ferrous ammonium sulfate being salable as a micro-nutrient for plants at \$15 - \$20 per kkg. This material is reported to be an excellent fertilizer for roses, rhododendrons and azaleas. However, due to the relatively small amount produced, the plant feels that independent marketing would be very difficult and expensive.

#### Treated Wastes

Because the electrolytic wastes at Plant A and C are extensively commingled with other plant wastes, no absolute value for the treated wastes at these plants can be given. Analytical data for the lagoon discharge at Plant A are as follows, in mg/l:

Suspended solids	15
Manganese	91
Chromium	0.08
pH	7.2

The treated discharge at Plant B is simply the discharge of the weak wastewater, as shown below.

<u>Parameter</u>	Concentration (mg/l)	Waste Load (kg/kg) (lb/1000 lb)
Suspended Solids	9	0.24
Manganese	21.7	0.58
Ammonia-N	16	0.43
pH	7.3	

Page Intentionally Blank



## SECTION VI

### SELECTION OF POLLUTION PARAMETERS

Pollutant parameters have been selected by industry categories on the basis of those which originate in the production processes in significant amounts and for which control and treatment technologies are reasonably available. The parameters for each category have also been selected so as to be the minimum number which will insure control. The pollutant parameters selected are as follows:

Suspended Solids

pH

Chromium (for electrolytic chromium only)

Manganese

Ammonia-N

Flow, of course, is basic in that its magnitude indicates the degree of recirculation and reuse practiced and the degree to which water conservation is utilized. Although effluent flow volumes are not specified in the recommended guidelines, its measurement and control is implicit in attaining the pollutant effluent loads specified.

#### Wastewater Constituents and Parameters of Pollutational Significance

The wastewater constituents of significance for the electrolytic segment of the ferroalloys industry include suspended solids, manganese, chromium, ammonia and pH. All other metals and chemical compounds in the wastewater that are not the subject of effluent limitations but which would normally be precipitated during treatment for removal of manganese or chromium are considered part of the suspended solids as well as any chemical or biological material adsorbed or entrapped by the suspended solids during clarification and separation. Thus, suspended solids are a wastewater constituent of pollutational significance.

pH is subject to effluent limitations because it indicates that excessive free acidity or alkalinity has been neutralized.

Chromium and manganese are the principal metals originating in the production processes. Hexavalent chromium is not included because the economics of the electrolytic chromium

process require the reduction of hexavalent chromium as an integral part of the process. Ammonia is included because of the very high concentrations found in the raw waste streams.

Thus, the major chemical, physical, and biological wastewater constituents and parameters of polluttional significance are as follows:

Ammonia  
Chromium, total  
Manganese  
Suspended solids  
pH

Other wastewater constituents of secondary importance in the industry that are not the subject of effluent limitations or standards of performance are as follows:

Iron  
Aluminum  
Total dissolved solids  
Chemical oxygen demand  
Turbidity  
Color  
Temperature

### Rationale for the Selection of Pollutant Parameters

#### Total Suspended Solids

Suspended solids include both organic and inorganic materials. The inorganic components include sand, silt, and clay. The organic fraction includes such materials as grease, oil, tar, animal and vegetable fats, various fibers, sawdust, hair, and various materials from sewers. These solids may settle out rapidly and bottom deposits are often a mixture of both organic and inorganic solids. They adversely affect fisheries by covering the bottom of the stream or lake with a blanket of material that destroys the fish-food bottom fauna or the spawning ground of fish.

In raw water sources for domestic use, state and regional agencies generally specify that suspended solids in streams shall not be present in sufficient concentration to be objectionable or to interfere with normal treatment processes. Suspended solids in water may interfere with many industrial processes, and cause foaming in boilers, or encrustations on equipment exposed to water, especially as the temperature rises. Suspended solids are undesirable in

water for textile industries; paper and pulp; beverages; dairy products; laundries; dyeing; photography; cooling systems, and power plants. Suspended particles also serve as a transport mechanism for pesticides and other substances which are readily sorbed into or onto clay particles.

Solids may be suspended in water for a time, and then settle to the bed of the stream or lake. Those settleable solids discharged with man's wastes may be inert, slowly biodegradable materials, or rapidly decomposable substances. While in suspension, they increase the turbidity of the water, reduce light penetration and impair the photosynthetic activity of aquatic plants.

Solids in suspension are aesthetically displeasing. When they settle to form sludge deposits on the stream or lake bed, they are often much more damaging to the life in water, and they retain the capacity to displease the senses. Solids, when transformed to sludge deposits, may do a variety of damaging things, including blanketing the stream or lake bed and thereby destroying the living spaces for those benthic organisms that would otherwise occupy the habitat.

Turbidity is principally a measure of the light absorbing properties of suspended solids. It is frequently used as a substitute method of quickly estimating the total suspended solids when the concentration is relatively low.

#### pH

The term pH is a logarithmic expression of the concentration of hydrogen ions. At a pH of 7, the hydrogen and hydroxyl ion concentrations are essentially equal and the water is neutral. Lower pH values indicate acidity while higher values indicate alkalinity. The relationship between pH and acidity or alkalinity is not necessarily linear or direct.

Waters with a pH below 6.0 are corrosive to water works structures, distribution lines, and household plumbing fixtures and can thus add such constituents to drinking water as iron, copper, zinc, cadmium and lead. The hydrogen ion concentration can affect the "taste" of the water. At a low pH water tastes "sour". The bactericidal effect of chlorine is weakened as the pH increases, and it is advantageous to keep the pH close to 7. This is very significant for providing safe drinking water.

Extremes of pH or rapid pH changes can exert stress conditions or kill aquatic life outright. Dead fish,

associated algal blooms, and foul stenches are aesthetic liabilities of any waterway. Even moderate changes from "acceptable" criteria limits of pH are deleterious to some species. The relative toxicity to aquatic life of many materials is increased by changes in the water pH. Metallo cyanide complexes can increase a thousand-fold in toxicity with a drop of 1.5 pH units. The availability of many nutrient substances varies with the alkalinity and acidity. Ammonia is more lethal with a higher pH.

The lacrimal fluid of the human eye has a pH of approximately 7.0 and a deviation of 0.1 pH unit from the norm may result in eye irritation for the swimmer. Appreciable irritation will cause severe pain.

### Chromium

Chromium, in its various valence states, is hazardous to man. It can produce lung tumors when inhaled and induces skin sensitizations. Large doses of chromates have corrosive effects on the intestinal tract and can cause inflammation of the kidneys. Levels of chromate ions that have no effect on man appear to be so low as to prohibit determination to date.

The toxicity of chromium salts toward aquatic life varies widely with the species, temperature, pH, valence of the chromium, and synergistic or antagonistic effects, especially that of hardness. Fish are relatively tolerant of chromium salts, but fish food organisms and other lower forms of aquatic life are extremely sensitive. Chromium also inhibits the growth of algae.

In some agricultural crops, chromium can cause reduced growth or death of the crop. Adverse effects of low concentrations of chromium on corn, tobacco and sugar beets have been documented.

### Manganese

The presence of manganese may interfere with water usage, since manganese stains materials, especially when the pH is raised as in laundering, scouring, or other washing operations. These stains, if not masked by iron, may be dirty brown, gray or black in color and usually occur in spots and streaks. Waters containing manganous bicarbonate cannot be used in the textile industries, in dyeing, tanning, laundering, or in hosts of other industrial uses. In the pulp and paper industry, waters containing above 0.05 ppm manganese cannot be tolerated except for low-grade

products. Very small amounts of manganese--0.2 to 0.3 ppm-- may form heavy encrustations in piping, while even smaller amounts may form noticeable black deposits.

### Ammonia

Ammonia is a common product of the decomposition of organic matter. Dead and decaying animals and plants along with human and animal body wastes account for much of the ammonia entering the aquatic ecosystem. Ammonia exists in its non-ionized form only at higher pH levels and is the most toxic in this state. The lower the pH, the more ionized ammonia is formed and its toxicity decreases. Ammonia, in the presence of dissolved oxygen, is converted to nitrate ( $\text{NO}_3$ ) by nitrifying bacteria. Nitrite ( $\text{NO}_2$ ), which is an intermediate product between ammonia and nitrate, sometimes occurs in quantity when depressed oxygen conditions permit. Ammonia can exist in several other chemical combinations including ammonium chloride and other salts.

Nitrates are considered to be among the poisonous ingredients of mineralized waters, with potassium nitrate being more poisonous than sodium nitrate. Excess nitrates cause irritation of the mucous linings of the gastrointestinal tract and the bladder; the symptoms are diarrhea and diuresis, and drinking one liter of water containing 500 mg/l of nitrate can cause such symptoms.

Infant methemoglobinemia, a disease characterized by certain specific blood changes and cyanosis, may be caused by high nitrate concentrations in the water used for preparing feeding formulae. While it is still impossible to state precise concentration limits, it has been widely recommended that water containing more than 10 mg/l of nitrate nitrogen ( $\text{NO}_3\text{-N}$ ) should not be used for infants. Nitrates are also harmful in fermentation processes and can cause disagreeable tastes in beer. In most natural water the pH range is such that ammonium ions ( $\text{NH}_4^+$ ) predominate. In alkaline waters, however, high concentrations of un-ionized ammonia in undissociated ammonium hydroxide increase the toxicity of ammonia solutions. In streams polluted with sewage, up to one half of the nitrogen in the sewage may be in the form of free ammonia, and sewage may carry up to 35 mg/l of total nitrogen. It has been shown that at a level of 1.0 mg/l un-ionized ammonia, the ability of hemoglobin to combine with oxygen is impaired and fish may suffocate. Evidence indicates that ammonia exerts a considerable toxic effect on all aquatic life within a range of less than 1.0 mg/l to 25 mg/l, depending on the pH and dissolved oxygen level present.

Ammonia can add to the problem of eutrophication by supplying nitrogen through its breakdown products. Some lakes in warmer climates, and others that are aging quickly are sometimes limited by the nitrogen available. Any increase will speed up the plant growth and decay process.

### Rationale for Rejection of Other Wastewater Constituents as Pollutants

#### Metals

The rationale for rejection of any metal other than manganese or chromium as a pollutant parameter is based on one or more of the following reasons:

- (1) They would not be expected to be present in electrolytic wastes in significant amounts (e.g., uranium, mercury, arsenic), or
- (2) They will be removed simultaneously by coprecipitation and clarification along with chromium and/or manganese (e.g., iron), or
- (3) Insufficient data exists upon which to base effluent limitations and standards of performance.

#### Dissolved Solids

Dissolved solids do not constitute an important parameter indicative of pollution when associated heavy metals are also the subject of effluent limitations. Although the concentration of total dissolved solids will become higher as efforts are directed to reducing water use and volume of effluent discharged, the total quantity of dissolved solids will remain unchanged.

#### Turbidity

Turbidity is indirectly measured and controlled independently by the limitation on suspended solids.

#### Color

Color is not usually significant in wastewater from ferroalloys and is indirectly controlled by the effluent limitations on suspended solids and on total metal which controls the amount of colloidal metal that could color the effluent.

## Temperature

Temperature is not considered a significant pollution parameter in the ferroalloys industry. However, cooling water used to cool the cells may contain pollutants from leaks in the system. Insufficient data exists upon which to base effluent limitations and standards of performance.

Page Intentionally Blank



## SECTION VII

### CONTROL AND TREATMENT TECHNOLOGY

Of the various control and treatment technologies available, recirculation and reuse of water is the generally most applicable and singly most effective method of reducing or eliminating the discharge of pollutants. So long as any required blowdown discharge is treated to the same effluent concentration as once-through water, it is obvious that the load reduction for each contaminant will be in direct proportion to the percentage of water recirculated. The only restrictions on the applicability of such technology are the water qualities required for particular uses (including dissolved solids buildup due to evaporation) and, of course, the costs involved. Water quality restrictions can generally be handled by using fresh makeup water at the points requiring highest quality water.

#### SUSPENDED SOLIDS

Suspended solids can be removed by plain sedimentation, flocculation-clarification, and filtration. Plain sedimentation in lagoons, basins, or clarifiers of sufficient sizes in relation to the hydraulic load will reduce suspended solids to 50-100 mg/l depending upon particle size, the lower concentrations being typical for coarse solids and the higher for finer solid particles. Lagoons are less expensive than clarifiers in capital and operating costs, but require much more land area. Plant A adds a flyash slurry from a captive power plant to the large settling lagoon and sampling indicated that this resulted in an average effluent suspended solids level of 15 mg/l. Flocculator-clarifiers, i.e., the use of chemical coagulants and/or polyelectrolytes followed by clarification will produce effluents with suspended solids concentrations of 25 mg/l on the average but may occasionally exceed 45 mg/l at times. Rapid sand filters will regularly produce effluents with suspended solids concentrations of 15 mg/l and often of 10 mg/l or less. However, sand filters may require some pretreatment to decrease the suspended solids loading, since otherwise excessively frequent back-washing would be required.

## ACID SOLUTIONS AND METALLIC SALTS

Manganese, chromium and iron, to the extent they are present as dissolved salts, are removed by neutralization, at a pH above 9.5 for manganese, and at about 8 for chromium and iron. This is followed by precipitation and sedimentation. Polyelectrolytes are usually used to promote sedimentation. Sufficiently high pH, adequate sedimentation and oxidation is required for low effluent concentrations. Manganese removal is also assisted by the addition of chlorine. Chromium is significantly soluble above and below the optimum pH of 8.0, while the pH for the optimum precipitation of manganese is 9.5 or higher. After the metals are precipitated and the solution is clarified, the pH of the wastewater should be made acceptable for discharge by neutralization if necessary.

Optimum precipitation of the metal ions depends primarily on pH and the valence states. The valence state is of particular importance for chromium; it precipitates more readily when reduced to trivalent chromium.

Other methods for removal of manganese are found in the literature, but are probably unfeasible for treatment of wastewaters containing several thousand ppm. For example, the manganese zeolite process, wherein water is passed through a manganese zeolite bed, which acts as an oxidizing contact medium and as a filter medium, is used for potable water treatment. At a flow rate and manganese concentration comparable to those at Plant A, about 63,000 ft<sup>3</sup> of manganese zeolite would be required if a 24 hour period were desired between regenerations. Additionally, 5000 kg (11,000 lb) per day of potassium permanganate would be consumed.

### Ammonia

Ammonia can be removed from waste waters by either biological or physical/chemical treatment.

Biological treatment by activated sludge can reduce ammonia concentrations to less than 5 mg/l. Ammonia is oxidized to NO<sub>3</sub> in aerobic treatment and the nitrate broken down to nitrogen and oxygen in anaerobic treatment. A study done on the biological treatment of ammonia liquors from cokemaking operations, which are comparable in concentration to those from electrolytic plants, indicated that this system is effective, but the costs when scaled to the volumes at electrolytic plants are high.

Physical/chemical treatment may involve either removal of ammonia from wastes by stripping or oxidation by breakpoint chlorination. Breakpoint chlorination requires at least 2.0 moles of chlorine per mole of ammonia. Ammonia is first converted to chloramines. Then the chlorine will oxidize the chlorinated compound and the ammonia will be oxidized to nitrogen and hydrogen. After this point, there will begin to be a free chlorine residual -- hence the name 'breakpoint chlorination.'

Air stripping, i.e., using air to remove the ammonia, is employed for municipal wastes. However, influent ammonia concentrations of demonstrated systems were substantially lower than electrolytic wastewaters. Additionally, this technique may result in air quality deterioration.

Steam stripping, commonly used in both the steel and fertilizer industries for removal of ammonia from wastes, may offer the greatest hope for recovery of costs and of a useful material as an ammonia treatment method for the electrolytic ferroalloys industry. It has been used for treating wastes of high concentrations and generally involves liming to cause the fixed ammonia in the wastes to convert to free ammonia and distillation to remove the ammonia. Commonly, the ammonia is then converted to ammonium sulfate by treating with dilute sulfuric acid. Stripping can recover ammonia either in the aqueous or anhydrous forms, both of which might be reusable in the electrolytic processes. However, the large operating costs associated with the process are only partially offset by the savings realized by reduced purchases of ammonia for the process.

Ion exchange is used in the fertilizer industry for removal of ammonium nitrate from wastewater and regenerating it from the resins. It may also be applicable to ferroalloys. However, this is a fairly complicated system requiring two operators per shift (at a flow of 1000 gpm). Increased labor costs alone, therefore, appear to make this option economically impractical at this time.

Ammonia can be removed from electrolytic chromium wastewaters by crystallization of the ferrous ammonium sulfate. This is more or less uniformly employed by electrolytic chromium producers who sell or give away the product, thereby removing ammonia from the water to be discharged. The ammonium sulfate in the wastewater from electrolytic manganese production might also be removed from wastewater by crystallization, but it may be necessary to concentrate the wastewater stream in order to remove it.

This could be accomplished by segregating the relatively small quantity of concentrated waste which is dumped, or by evaporation or reverse osmosis. The resultant ammonium sulfate may be recyclable to the process.

The treatment processes discussed here are largely conventional. The main problem in this industry appears to be the reduction of waste water volumes requiring treatment to a minimum, design of adequately sized facilities (particularly for suspended solids removal), proper operation (preferably with instrumental control), and operator training.

The highest degree of end-of-pipe treatment presently practiced consists of settling, aeration, solar evaporation or neutralization, all in lagoons. The lowest discharge levels appear at the new plants, where in-plant controls of wastewater were built into the plant, in the way of collection of cell spillage, recirculation, collection and hauling of filter muds (as opposed to hydraulic transport).

It appears that the best and most economical alternatives for existing plants involve end-of-pipe treatment of the waste water, followed by recirculation.

With regard to this treatment, it should be noted that treatment is simplified if smaller, more concentrated, volumes are handled. This may be accomplished by separation of wastes, by concentrating the waste streams, and so forth. For example, mixture of the weak manganese waste waters with wastewaters from other plant operations as at Plants A and C would entail the treatment of a vast quantity of wastewater for, say, ammonia, when the smaller volume from the electrolytic operation could be treated more economically and efficiently (in terms of load) separately. If ammonia is only present in significant quantities from the electrolytic operations, but the wastes are mixed with other wastes for a total flow of 10,000 gpm (vs. 500 gpm), the load after treatment would be 20 times higher than if the wastes were treated separately, if a given treatment yields the same effluent concentration regardless of influent concentrations. By contrast, waste streams which require treatment for common parameters can be mixed to reduce the overall costs of treatment by economies of scale.

Based upon the plant survey data and the foregoing discussions of process and waste water treatment technology, the treatment technologies identified as applicable to the various industry categories are as follows:

## Category I. Electrolytic Manganese Products

Level I - pH adjustment, flocculation-clarification and neutralization for the weak electrolytic manganese wastes and the manganese dioxide wastes. For the strong electrolytic manganese wastes, clarification and recirculation.

Level II - Level I plus treatment of half the weak electrolytic manganese wastes and the manganese dioxide wastes for ammonia via breakpoint chlorination, then neutralization and discharge. Recirculation after neutralization of the remainder.

Level III - Limitation of the quantity of wastewater by in-plant recirculation, mechanical (non-hydraulic) transport of filter residues, and treatment for discharge the same as for Level I with the addition of breakpoint chlorination for electrolytic manganese. Same as Level II for manganese dioxide.

## Category II - Electrolytic Chromium

Level I - pH adjustment, sedimentation, pH adjustment, clarification-flocculation, treatment for ammonia via breakpoint chlorination and neutralization for discharge.

Level II - Level I plus recirculation of half of the wastes after neutralization.

Level III - Limitation of the quantity of wastewater by in-plant recirculation, mechanical (non-hydraulic) transport of filter residues, and treatment for discharge the same as for Level I.

Sketches of these treatment levels are shown in Figures 6 and 7.

The treatment systems shown in Figures 6 and 7 are not utilized in toto in any one plant in the industry. However, the modules which comprise the systems are in use in this, or similar, industries.

Plant P, studied as part of the Alloy and Stainless Steel Industry (Ref. 12), utilizes a treatment system for chromium neutralization and clarification similar to that shown in the first step of Figure 7. This system had an average influent concentration of about 18 mg/l total chromium. After treatment, the average concentration was 0.10 mg/l. This system was operating on a continuous basis. Plant S of

the Iron and Steel Industry study (Ref. 10), achieved an average suspended solids concentration of 22 mg/l after clarification of scrubber water from a B.O.F. Plant D of the Phase I ferroalloys study (Ref. 13) demonstrates the use of alkaline precipitation of metals and the use of sand filters, although not in a completely optimum manner. Breakpoint chlorination for ammonia treatment is commonly employed in municipal wastewater treatment. The treatment scheme shown may be thought to be based upon the components of all these systems, although as discussed above, any particular plant may not find it necessary to utilize the entire system.

#### STARTUP AND SHUTDOWN PROBLEMS

There have been no problems of consequence identified in connection with the startup or shutdown of production facilities insofar as waste water control and treatment is concerned. There might be some upsets in undersized lagoons or clarifiers used in once-through systems if the water flow is abruptly started after a shutdown. Proper operating procedures such as surge ponds to adjust or even out flows can easily handle such occurrences and there would be little or no effect in sufficiently large facilities.

Loss of power can effect most of the treatment systems such as chemicals addition for flocculation, ammonia oxidation or metals precipitation. In such cases, however, the production process producing the wastewater also will stop and little effect on waste water treatment would result.

Figure 6  
Electrolytic Manganese Products  
Treatment System

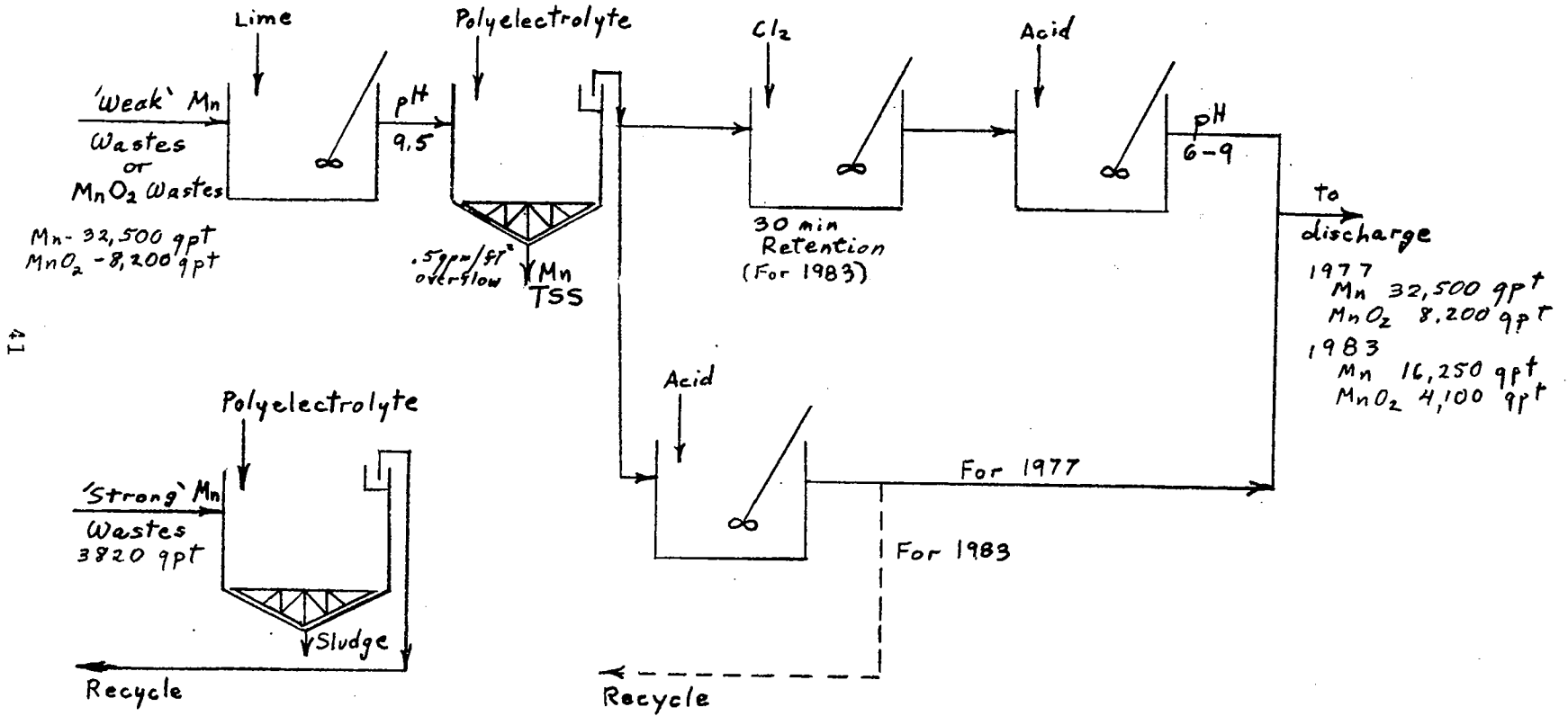
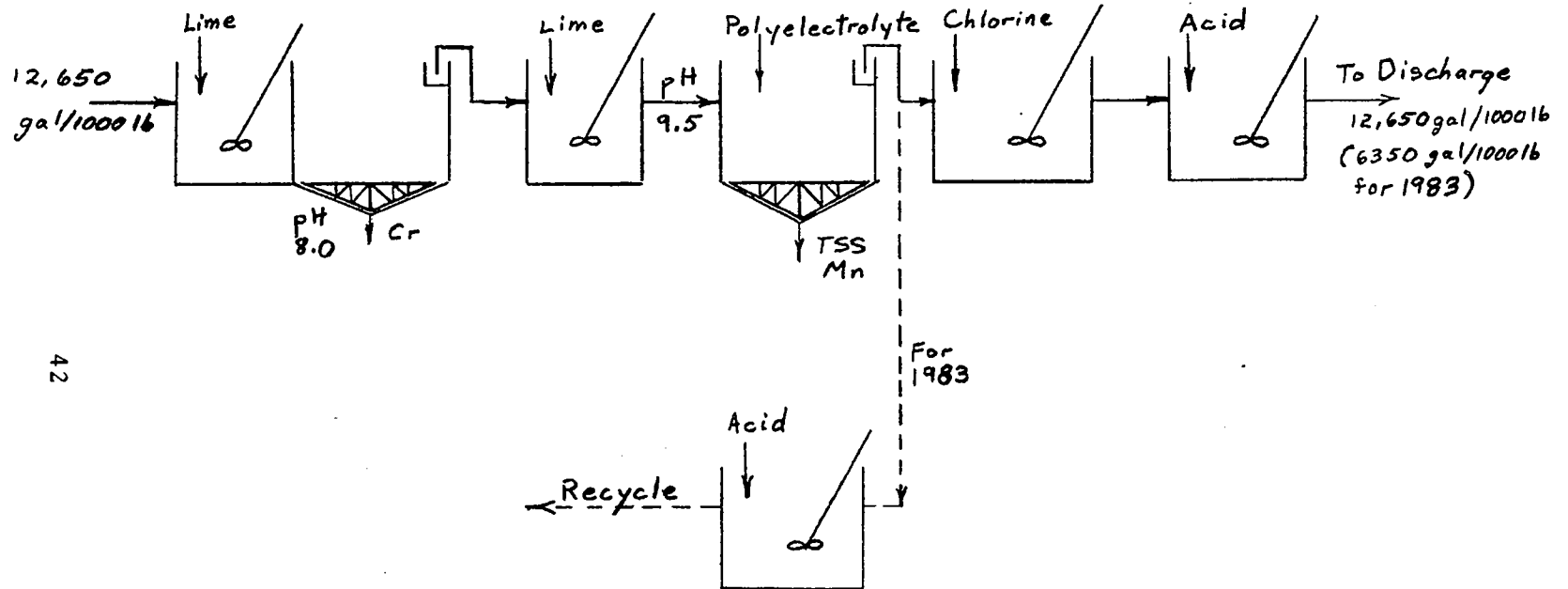

Figure 7  
Electrolytic Chromium Treatment System





## SECTION VIII

### COST, ENERGY AND NON-WATER QUALITY ASPECTS

Capital and operating costs were supplied by Plants A, B, and C. The costs shown in Table 1 are estimates of the cost of the treatment systems shown in Figures 6 and 7. While these costs are estimates, they are representative of the actual costs which might be incurred by isolated plants producing these commodities. Some plants, such as B and D, which already have extensive recirculation systems installed, will incur very minor additional costs. Plant A can take advantage of the number of waste streams and by suitable combinations reduce the cost.

Capital and operating costs are given in terms of units of production. These costs were based upon cost of capital at an interest rate of 8 percent, and a depreciation period of 15 years. Power costs were calculated as a percentage of the annual operating cost by the ratio of power to total operating costs at Plant B, and have been assumed at one cent per kwhr. Operating costs include annualized capital costs.

The cost of land was not included as part of the total investment, since it is thought that very few (if any) plants will need to purchase land for wastewater treatment. All of the plants have large lagoon systems, which could either be utilized as part of a wastewater treatment system, or used for landfilling sludge.

The following bases were used for cost calculations by Category and Treatment Level:

#### Category I, Treatment Level I.

Costs were developed for the treatment system as shown in figure 6, based on the flows at Plant A. The costs include mechanical equipment, tanks, piping, valves, electrical, engineering, installation, etc. They are based upon the complete system less breakpoint chlorination and recirculation of the weak electrolytic manganese or manganese dioxide wastes. The investment costs will probably be less (per kkg(ton)) for a plant larger than the model, and greater for a plant smaller than the model.

TABLE 1

TREATMENT LEVEL COSTS

	Manganese			Manganese Dioxide			Chromium		
	Level I	Level II	Level III	Level I	Level II	Level III	Level I	Level II	Level III
	<u>\$/ton</u>	<u>\$/ton</u>	<u>\$/ton</u>	<u>\$/ton</u>	<u>\$/ton</u>	<u>\$/ton</u>	<u>\$/ton</u>	<u>\$/ton</u>	<u>\$/ton</u>
Investment Cost	29.79	8.51	92.33	23.40	7.11	30.51	90.71	8.96	157.62
Capital Costs	1.49	.43	4.63	1.17	.36	1.53	4.55	.45	7.91
Depreciation	1.99	.57	6.16	1.56	.48	2.04	6.05	.60	10.51
Operating less									
Power	8.00	2.28	9.04	6.28	1.91	8.19	24.35	2.41	21.51
Power	.94	.27	1.06	.74	.22	.96	2.86	.28	2.52
Total Annual Cost	12.42	3.55	20.89	9.75	2.97	12.72	37.81	3.74	42.45
	<u>\$/kkg</u>	<u>\$/kkg</u>	<u>\$/kkg</u>	<u>\$/kkg</u>	<u>\$/kkg</u>	<u>\$/kkg</u>	<u>\$/kkg</u>	<u>\$/kkg</u>	<u>\$/kkg</u>
Investment Cost	27.08	7.74	83.93	21.27	6.47	27.74	82.46	8.15	143.29
Capital Costs	1.36	.39	4.21	1.07	.33	1.39	4.13	.41	7.19
Depreciation	1.81	.52	5.60	1.42	.43	1.85	5.50	.54	9.55
Operating less									
Power	7.27	2.08	8.22	5.71	1.74	7.45	22.14	2.19	19.56
Power	.85	.24	.96	.67	.20	.87	2.60	.26	2.29
Total Annual Cost	11.29	3.23	18.99	8.87	2.70	11.56	34.37	3.40	38.59

Operating and maintenance costs at this level of estimation are best figured as a percentage of capital costs for similar type plants. The "Inorganic Chemicals Industry Profile" indicated for 59 plants surveyed operating costs per annual unit of production equal to 28 percent of the capital cost per annual unit of production. The operating costs at Plant C of the Phase I ferroalloys study are equal to 23.4 percent per year of the capital cost. The operating costs at Plant D of the Phase I ferroalloys study are equal to 23.0 percent of the capital cost. The operating costs at Plant B of the ferroalloys Phase I study are equal to 30.9 percent per year of the capital costs. Operating costs are thus estimated on the basis of 30 percent per year of the estimated capital cost.

#### Category I, Treatment Level II.

These are incremental costs above Level I, and include costs of recirculation of the weak electrolytic manganese and manganese dioxide wastes and breakpoint chlorination, with a proportionate increase in annual and operating costs.

#### Category I, Treatment Level III

Costs for electrolytic manganese are based upon those at Plant B and have been expanded to include the cost of treatment of the wastewater for discharge. Costs for manganese dioxide are the total cost of Level II treatment. These are the total costs which a new plant might expect to incur, while those shown for Levels I and II are incremental costs.

#### Category II, Treatment Level I.

Costs were developed for the treatment system shown in Figure 7 less the recirculation portion and are based on the flow rate from the electrolytic chromium facility at Plant A. As before, the investment cost per unit of production will be somewhat higher for small plants and less for large plants.

#### Category II, Treatment Level II

The additional cost here is for the recirculation portion and the costs shown are incremental above Level I treatment.

## Category II, Treatment Level III

Total costs of inplant recirculation were scaled from those of Plant B and include the cost of treatment of the discharge stream as in Level I.

Figures 8 and 9 show the relative costs of treatment for reduction of effluent loads of the critical pollutants from the raw wastes. These curves provide graphical information of interest, but must be read in the context of the previously described Treatment Levels to be of value.

### ENERGY AND NON-WATER QUALITY ASPECTS

There are significant energy and nonwater quality aspects to the selection and operation of treatment systems. These may be considered as land requirements, air and solid waste aspects, by-product potentials, and energy requirements.

#### Land Requirements

One of the important aspects in the selection of wastewater treatment systems in this industry is the land required for water treatment systems. Many plants in this industry have extensive land areas available for such uses and may elect to use this land, and existing lagoons, as part of their water treatment system. Other plants might possibly not have land readily available and would have to select alternative treatment systems such as the use of filters for sludge dewatering, rather than sludge lagoons, for this reason alone.

#### Air and Solid Wastes

The solid waste produced by treatment of waste waters in the industry derives principally from electrolyte preparation as waste from leaching. The solid waste from leaching is produced whether the leach residue is hydraulically or mechanically transported and varies only in that the former produces a slurry, the latter a sludge. The slurry is generally accumulated in sludge lagoons or tailings ponds, while the sludge may be landfilled or simply piled. More careful attention should be directed to the disposal of these potentially harmful materials. Possible improvements might be landfilling in a sealed site, or encapsulation in concrete or polymers.

For those waste materials considered to be non-hazardous where land disposal is the choice for disposal, practices similar to proper sanitary landfill technology may be

followed. The principles set forth in the EPA's Land Disposal of Solid Wastes Guidelines (CFR Title 40, Chapter 1; Part 241) may be used as guidance for acceptable land disposal techniques.

For those waste materials considered to be hazardous, disposal will require special precautions. In order to ensure long-term protection of public health and the environment, special preparation and pretreatment may be required prior to disposal. If land disposal is to be practiced, these sites must not allow movement of pollutants such as fluoride and radium-226 to either ground or surface water. Sites should be selected that have natural soil and geological conditions to prevent such contamination or, if such conditions do not exist, artificial means (e.g., liners) must be provided to ensure long-term protection of the environment from hazardous materials. Where appropriate, the location of solid hazardous materials disposal sites should be permanently recorded in the appropriate office of the legal jurisdiction in which the site is located.

#### By-Product Potentials

The recovery and use of ferrous ammonium sulfate from electrolytic chromium production, rather than disposal by chemical precipitation and sedimentation depends upon local market conditions. However, since all producers have at least the equipment to produce a crude ferrous ammonium sulfate, recovery of this material may offer potential for the reduction of overall costs.

#### Energy Requirements

Power requirements for waste water treatment systems are generally low. Power uses range from less than one percent to two percent of the power used in the cell room.

#### Monitoring

For the purpose of writing a permit, one would need to know historical production figures for the plant. An alternative for plants which do not possess historical production data would be the use of capacity figures.

Historical data covering a year's time would probably be necessary, although in the case of a plant which is presently producing well below capacity, but plans to increase production in the future, a longer period might be necessary.

Once the permit has been issued, the plants would need to monitor the appropriate flows and concentrations of the pollutant parameters so that the pollution load from the plant may be reported as lb/day.

Figure 8

Cost of Treatment vs. Effluent Reduction  
Electrolytic Manganese Products

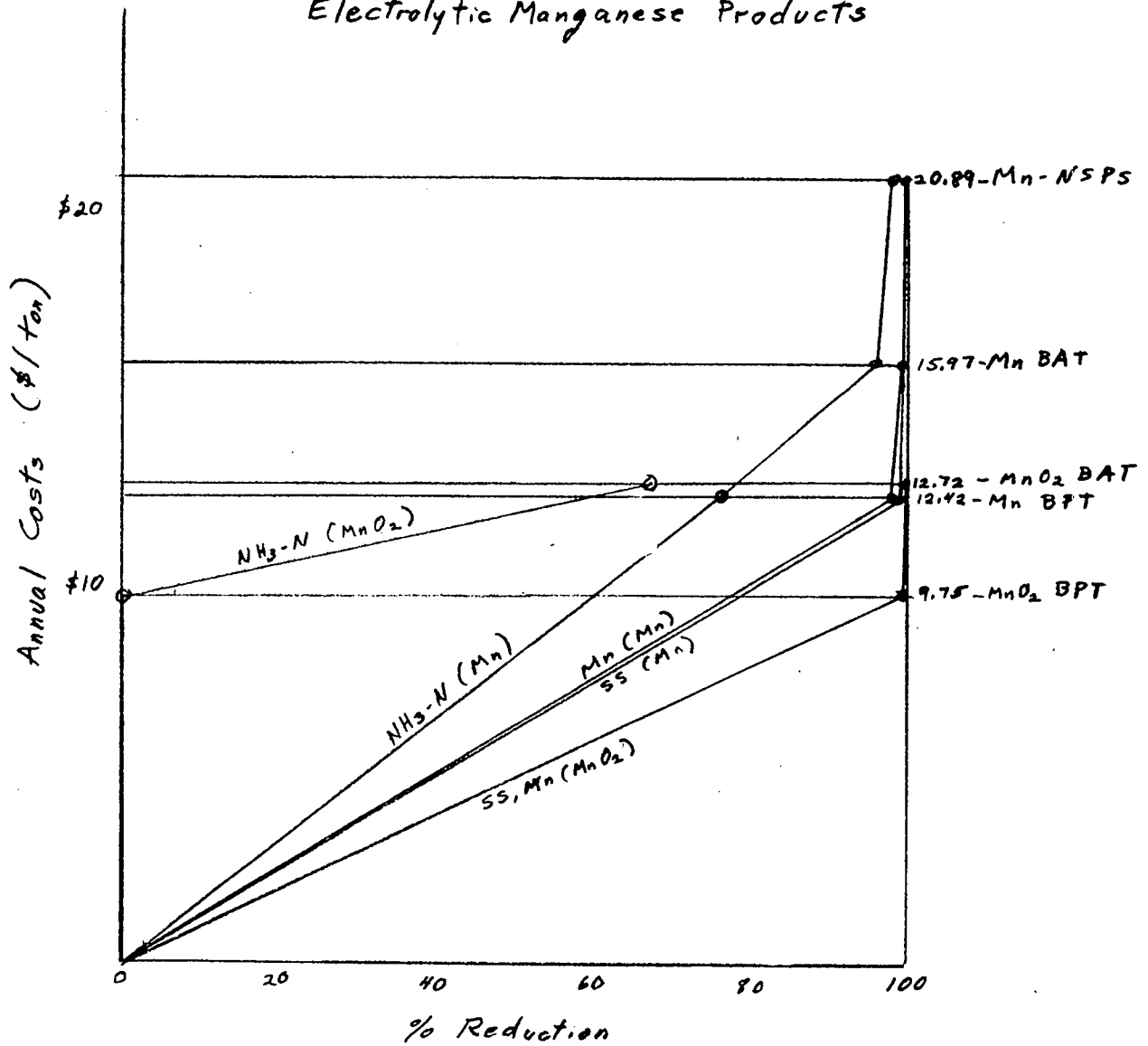
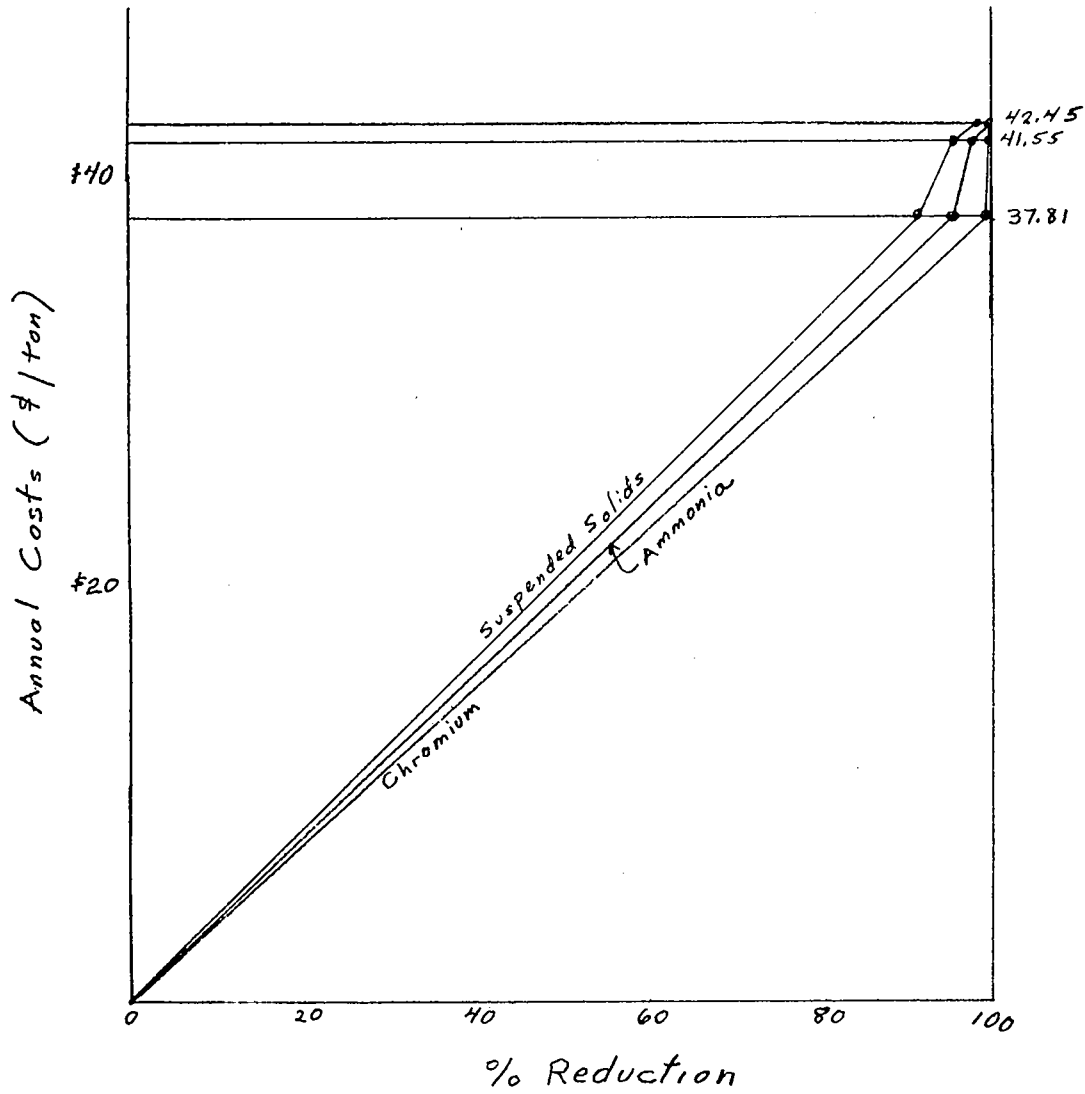

Figure 9

Cost of Treatment vs. Effluent Reduction  
Electrolytic Chromium





## SECTION IX

### BEST PRACTICABLE CONTROL TECHNOLOGY CURRENTLY AVAILABLE, GUIDELINES AND LIMITATIONS

#### INTRODUCTION

The effluent limitations which must be achieved by July 1, 1977 are to specify the degree of effluent reduction attainable through the application of the Best Practicable Control Technology Currently Available. This is generally based upon the average of the best existing plants of various sizes, ages and unit processes within the industrial category and/or subcategory.

Consideration must also be given to:

- a. The total cost of application of technology in relation to the effluent reduction benefits to be from such application.
- b. the size and age of equipment and facilities involved;
- c. the processes employed;
- d. the engineering aspects of the application of various types of control techniques;
- e. process changes;
- f. non-water quality environmental impact (including energy requirements).

Also, Best Practicable Control Technology Currently Available emphasizes treatment facilities at the end of a manufacturing process but includes the control technologies within the process itself when the latter are considered to be normal practice within an industry.

A further consideration is the degree of economic and engineering reliability which must be established for the technology to be "currently available." As a result of demonstration projects, pilot plants and general use, there must exist a high degree of confidence in the engineering and economic practicability of the technology at the time of commencement of construction or installation of the control facilities.

Definition of what constitutes 'best practicable' technology for many industries involves, at first, a general review of the industry to determine the best technologies being practiced in the industry. Then after closer review and investigation of these technologies, the 'best practicable' technology would be assessed as the average of the best, though not necessarily the best technology, after taking into account information relating to other factors spelled out in the Act. In those industries where present treatment is uniformly inadequate, a higher degree of treatment than is presently practiced may be required, based on a comparison with existing treatments for similar wastes in other industries. Factors for determining the 'best available' technology are similar, except that rather than assessing the average of the best, the focus is on the very best technology currently in use or demonstrably achievable.

Under this analysis of the statutory standard, it is the opinion of the Agency that it is not necessary that 'best practicable' technology be currently in use as a single treatment.

#### EFFLUENT REDUCTION ATTAINABLE THROUGH THE APPLICATION OF BEST PRACTICABLE CONTROL TECHNOLOGY CURRENTLY AVAILABLE (BPCTCA)

Based upon the information contained in Sections III through VIII of this report, a determination has been made that the degree of effluent reduction attainable through the application of the best practicable control technology currently available is the application of Level I Treatment as described in Section VII and below.

##### Category I - Electrolytic Manganese Products

pH adjustment, flocculation-clarification and neutralization for the weak electrolytic manganese wastes and the manganese dioxide wastes. For the strong electrolytic manganese wastes, clarification and recirculation.

##### Category II - Electrolytic Chromium

pH adjustment, sedimentation, pH adjustment, clarification-flocculation, treatment for ammonia via breakpoint chlorination and neutralization for discharge.

These guidelines were formulated on the basis of readily available technology which will achieve reasonable effluent quality by generally end-of-pipe treatment, i.e., with mostly once-through water use.

These guidelines do not appear to present any particular problems in implementation at existing plants, aside from required better operation and more extensive segregation of wastes from other plant wastes. The size or age of facilities has no bearing on applicability, aside from some differences in costs. The only process change required for manganese plants is the reuse of the strong wastes after clarification, which is demonstrated at Plant B.

The effluent limitations here apply to measurements taken at the outlet of the last waste water treatment process unit. The effluent loads representing the allowable 30 day average limitations applicable to the Best Practicable Control Technology Currently Available Guidelines and Limitations are summarized below. The 24 hour maximum effluent limitations are twice (two times) the allowable 30 day average limitations, except for pH.

	Effluent Limitations				pH
	kg/kkg (lb/1000 lb)				
	TSS	Mn	Cr	NH <sub>3</sub> -N	
Category I-Mn	3.389	1.356	--	20.334	6.0 - 9.0
Category I-MnO <sub>2</sub>	0.881	0.352	--	5.287	6.0 - 9.0
Category II	2.638	1.055	0.106	5.276	6.0 - 9.0

#### Category I

The costs here would be those given in Section VIII for treatment level I. The flow volumes upon which the limitations are based are 135,314 l/kkg (16,250 gal/1000 lb) for electrolytic manganese and 35,182 l/kkg (4,225 gal/1000 lb) for manganese dioxide.

Although the entire treatment system is not presently in use at any one plant, portions of the suggested technology as shown in Figure 6 are readily transferable from other plants within this or similar industries. No innovative or new technology is involved - rather, the application of existing and fairly pedestrian technology to this industry's problem.

#### Category II

The flow volumes upon which the limitations are based is 105,337 l/kkg (12,650 gal/1000 lb). In-plant recovery of ferrous ammonium sulfate should result in lowering or eliminating the cost of treatment for ammonia.

Although the technology is not in use at any one plant, the portions are in use at various plants or are readily transferrable.

The suggested guidelines do not appear to present any particular problems in implementation. The processes involved are all in present use in ferroalloy or similar plants or are common waste water treatment methods and no engineering problems are involved in design or construction. Process changes other than recirculation are not required in any existing plants and the size or age of facilities has little or no bearing on the applicability of these methods.

Some additional solid wastes are generated by the suggested treatment methods since better treatment than is presently practiced is suggested. Power consumption for treatment is about 1 to 2 percent of that used in the cell room.

## SECTION X

### BEST AVAILABLE TECHNOLOGY ECONOMICALLY ACHIEVABLE, GUIDELINES AND LIMITATIONS

#### INTRODUCTION

The effluent limitations which must be achieved by July 1, 1983 are to specify the degree of effluent reduction attainable through the application of the Best Available Technology Economically Achievable. Best Available Technology Economically Achievable is determined by the very best control and treatment technology employed by a specific point source within the industry category or by technology which is readily transferable from another industrial process.

Consideration must also be given to:

- a. The age of equipment and facilities involved;
- b. the process employed;
- c. the engineering aspects of the application of various types of control techniques;
- d. process changes;
- e. cost of achieving the effluent reduction resulting from the application of this level of technology;
- f. non-water quality environmental impact (including energy requirements).

Also, Best Available Technology Economically Achievable assesses the availability of in-process controls as well as additional treatment at the end of a production process. In-process control options include water re-use, alternative water uses, water conservation, by-product recovery, good housekeeping, and monitor and alarm systems.

A further consideration is the availability of plant processes and control techniques up to and including "no discharge" of pollutants. Costs for this level of control are to be the top-of-the-line of current technology subject to engineering and economic feasibility.

EFFLUENT REDUCTION ATTAINABLE THROUGH THE APPLICATION OF  
BEST AVAILABLE TECHNOLOGY ECONOMICALLY ACHIEVABLE (BATEA)

Based upon the information contained in Sections III through VIII of this report, a determination has been made that the degree of effluent reduction attainable through the application of the best available control technology economically achievable is the application of the Level II Treatments as described in Section VII and below.

Category I - Electrolytic Manganese Products

Level I plus treatment of half the weak electrolytic manganese wastes and the manganese dioxide wastes for ammonia via breakpoint chlorination, then neutralization and discharge. Recirculation after neutralization of the remainder.

Category II - Electrolytic Chromium

Level I plus recirculation of half of the wastes after neutralization.

These guidelines were formulated on the basis of technology that is in use in surveyed plants or transferrable. These guidelines do not appear to present any particular problems in implementation from an engineering standpoint and require no process changes other than recirculation.

The effluent limitations here apply to measurements taken at the outlet of the last waste water treatment process unit. The 30 day average effluent loads applicable to the Best Available Technology Economically Achievable Guidelines and Limitations are summarized below. The 24 hour maximum effluent limitations are twice (two times) the allowable 30 day average limitations, except for pH.

	Effluent Limitations				
	TSS	Mn	Cr	NH <sub>3</sub> -N	pH
Category I-Mn	1.695	0.339		3.389	6.0 - 9.0
Category I-MnO <sub>2</sub>	0.441	0.088		0.881	6.0 - 9.0
Category II	1.324	0.265	0.027	2.649	6.0 - 9.0

## Category I

The effluent load reduction above Level I is primarily due to the effluent reduction attained through recirculation, although some of the reduction is due to lower concentrations in the effluent. Portions of the technology described are in use at various ferroalloys plants, and no new or innovative technology is required. The flow volumes upon which the limitations are based are 67,657 l/kkg (8125 gal/1000 lb) for electrolytic manganese and 17,590 l/kkg (2110 gal/1000 lb) for manganese dioxide.

## Category II

Again, load reduction above Level I is due primarily to the reduction in effluent volume attained by recirculation. As before, no innovative technology is required. The flow volume upon which the limitations are based is 52,876 l/kkg (6350 gal/1000 lb).

## Summary

The suggested Guidelines present no particular problems in implementation from an engineering aspect and require no process changes other than water reuse. Water reuse and good housekeeping are emphasized. Age of equipment and facilities are of no particular importance although they may slightly affect the costs of achieving the effluent limitations.

No additional solid wastes of significance are created by the suggested treatment methods. Increased power consumption may amount to as much as 2 percent of productive power in the most energy intensive water treatment system. The effluent limitations here apply to measurements taken at the outlet of the last waste water treatment process unit. It is not judged to be practical to require the treatment or control of runoff due to storm water for the 1983 standards for existing plants. In one steel mill where it was proposed to collect runoff and treat the collected water in a lagoon, the costs involved were equal to the total expenditures for a minimum discharge recirculation system for process wastewaters.

Page Intentionally Blank



## SECTION XI

### NEW SOURCE PERFORMANCE STANDARDS AND PRETREATMENT STANDARDS

#### INTRODUCTION

The effluent limitations which must be achieved by new sources, i.e., any source, the construction of which is started after publication of new source performance standard regulations, are to specify the degree of treatment available through the use of improved production processes and/or treatment techniques. Alternative processes, operating methods or other alternatives must be considered. The end result is to identify effluent standards achievable through the use of improved production processes (as well as control technology). A further determination which must be made for the new source performance standards is whether a standard permitting no discharge of pollutants is practicable.

Consideration must also be given to:

- a. The type of process employed and process changes;
- b. operating methods;
- c. batch as opposed to continuous operation;
- d. use of alternative raw materials and mixes of raw materials;
- e. use of dry rather than wet processes;
- f. recovery of pollutants as by-products.

In addition to recommending new source performance standards and effluent limitations covering discharges into waterways, constituents of the effluent discharge must be identified which would interfere with, pass through or otherwise be incompatible with a well designed and operated publicly owned activated sludge or trickling filter waste water treatment plant. A determination must be made as to whether the introduction of such pollutants into the treatment plant should be completely prohibited.

**EFFLUENT REDUCTION ATTAINABLE THROUGH THE APPLICATION OF NEW SOURCE PERFORMANCE STANDARDS**

Based upon the information contained in Sections III through VIII of this report, a determination has been made that the degree of effluent reduction attainable by new sources is the application of the Level 3 treatments as described in Section VII.

The new source performance standards are based upon the best available demonstrated control technology, process, operating methods, or other alternatives which are applicable to new sources. The best available demonstrated control technology for new sources is as follows, by category:

Category I - Limitation of the quantity of wastewater by in-plant recirculation mechanical (non-hydraulic) transport of filter residues, and treatment for discharge the same as for Level I with the addition of breakpoint chlorination for electrolytic manganese. For manganese dioxide, the same as for BATEA.

Category II - Limitation of the quantity of wastewater by in-plant recirculation, mechanical (non-hydraulic) transport of filter residues, and treatment for discharge the same as for Level I.

The 30 day average new source limitations are as follows, by category. The 24 hour maximum effluent limitations are twice (two times) the allowable 30 day average limitations, except for pH.

	Effluent Limitations					pH
	kg/kg (lb/1000 lb)					
	TSS	Mn	Cr	NH <sub>3</sub> -N		
Category I-Mn	0.740	0.148	--	1.481	6.0 - 9.0	
Category I-MnO <sub>2</sub>	0.441	0.088	--	0.881	6.0 - 9.0	
Category II	0.417	0.083	0.008	0.834	6.0 - 9.0	

These performance standards have been selected on the basis of the following assumptions and considerations:

**Category I**

The standard for this subcategory is based on the actual performance of Plant B, with treatment to reduce the manganese to more acceptable levels. The standard for manganese dioxide is based upon the application of the best

available control technology economically achievable. The flow volumes upon which the limitations are based are 29,561 l/kg (3550 gal/1000 lb) for electrolytic manganese and 17,590 l/kg (2110 gal/1000 lb) for manganese dioxide. Costs are as shown in Section VIII.

## Category II

The standard here is based upon the reported performance of Plant D, with the exception that an allowance has been made for the wastes which are evaporated at Plant D, but which plants at other locations with greater rainfall than evaporation rates might find it necessary to discharge. The flow volume upon which the limitations are based is 16,654 l/kg (2000 gal/1000 lb). Costs are as shown in Section VIII.

## SUMMARY

New plants in this segment of the ferroalloys industry have more and less expensive options available as regards minimization of discharge than do older, existing plants. New plants can design and construct recirculation and treatment systems as an integral part of the operation, while for existing plants such modifications might be either exorbitant or simply very difficult to accomplish.

For the new source performance standards, it should be additionally specified that all measurements taken for purposes of meeting the effluent limits should be at the plant outfall, if the new source is a new plant.

For new source performance standards applied to new plants, measurements should be taken at the plant outfall. This means that run-off from materials handling and storage, sludge disposal, etc. must be collected and treated or that storm water must not contact such sources of pollution. Control methods can include wastes disposal in landfills or impoundment or diversion of storm water. The option, of course, of treating run-off is available. Such measures can be incorporated into new plants, but would generally be impractical in old plants. If the new source is part of an existing plant, the applicable measurement should be taken at the outlet of the last waste water treatment process unit.

## PRETREATMENT STANDARDS

The pretreatment standards under Section 307 (c) of the Act, for a source within the ferroalloys industry which is an industrial user of a publicly owned treatment works (and which would be a new source subject to Section 306 of the Act, if it were to discharge to navigable waters), shall be the standard set forth in Part 128, 40 CFR, except that the pretreatment standard for incompatible pollutants shall be the standard of performance for new sources of that subcategory. If the publicly owned treatment works is committed, in its NPDES permit, to remove a specified percentage of any compatible pollutant, the pretreatment standard applicable to users of such treatment works shall be corresponding reduced for that pollutant.

## SECTION XII

### ACKNOWLEDGEMENTS

Sincere thanks is expressed to the author's associates in the Effluent Guidelines Division of the Environmental Protection Agency, particularly Messrs. Walter J. Hunt, Ernst P. Hall, and Allen Cywin for their assistance and many helpful suggestions during the course of this project.

The Datagraphics, Inc. staff members who contributed to the preparation of the draft Contractor's report included Dr. H. C. Bramer, Messrs. E. Shapiro, N. W. Elliott, D. C. Bramer, D. Riston, G. Robinson, C. A. Caswell, and A. W. Leavitt, and Mrs. K. L. Durkin. Particular appreciation is extended to Ms. Darlene Speight for her long hours and diligence in editing and typing this report.

Thanks are extended to those companies and their plant personnel who permitted sampling surveys at their plants. Particular thanks are extended to the following persons who provided cooperation in performing this study:

Foote Mineral Company	Mr. W. D. Morgan Mr. P. M. Dampf
Kerr-McGee Chemical Corporation	Mr. T. L. Hurst
Prairie Chemical Company	Mr. Denver Harris
Union Carbide Corporation	Dr. C. R. Allenbach Mr. E. Springman Mr. G. Porter Mr. J. E. Banasik

Thanks are also given to the members of the EPA Working Group/Steering Committee for their cooperation and assistance. They are Messrs. Walter J. Hunt, T. Powers, Dr. H. Durham and Ms. N. Speck.

Page Intentionally Blank

## SECTION XIII

### REFERENCES

1. Smith, A. E., "A Study of the Variation with pH of the Solubility and Stability of Some Metal Ions at Low Concentrations in Aqueous Solution (Part 1 and 2)", Analyst, January and March 1973, pp. 65-68, pp. 209-212.
2. Sully, A. H., "Metallurgy of the Rarer Metals - 3, Manganese", Academic Press Inc., New York, pp. 57-79.
3. Carosella, M. C. and Mettler, J. D., "The First Commercial Plant for Electrowinning Chromium from Trivalent Salt Solutions", Proceedings of a Conference held at the 1955 Metal Congress and Exposition of the American Society for Metals, Copyright 1957, pp. 75-90.
4. Dean, Reginald S., "Electrolytic Manganese and Its Alloys", The Ronald Press Company, New York, pp. 3-76.
5. Sully, A. H., "Metallurgy of the Rarer Metals - 1, Chromium", Academic Press Inc., New York, pp. 17-55.
6. "Facts about Manganese", United States Department of the Interior, Bureau of Mines, July 1953.
7. Bennett, R. H., "A Decade of Electrolytic Manganese", Engineering and Mining Journal, 1949.
8. "124 Process Flowsheets", published by Chemical Engineering, New York, pp. 22,26.
9. "Development Document for Effluent Limitations Guidelines and New Source Performance Standards - Basic Fertilizer Chemicals Segment of the Fertilizer Manufacturing Point Source Category", EPA-440/1-74-011-a, (March 1974), Office of Air and Water Programs, U.S. Environmental Protection Agency, Washington, D.C. 20460.
10. "Development Document for Proposed Effluent Limitations Guidelines and New Source Performance Standards for the Steel Making Segment of the Iron and Steel Manufacturing Point Source Category", EPA-440/1-73/024, (February 1974), Office of Air and Water Programs, U.S. Environmental Protection Agency, Washington, D.C. 20460.

11. "Biological Removal of Carbon and Nitrogen Compounds from Coke Plant Wastes", EPA-R2-73-167, (April 1973), Office of Research and Monitoring, U.S. Environmental Protection Agency, Washington, D.C. 20460.

12. "Draft Development Document for Effluent Limitations Guidelines and Standards of Performance--Alloy and Stainless Steel Industry", Datagraphics, Inc., Pittsburgh, PA, January 1974 (EPA Contract No. 68-01-1527).

13. "Development Document for Effluent Limitations Guidelines and New Source Performance Standards for the Smelting and Slag Processing Segments of the Ferroalloy Manufacturing Point Source Category", EPA-440/1-74-008a, (February 1974), Office of Air and Water Programs, U.S. Environmental Protection Agency, Washington, D.C. 20460.



## SECTION XIV

### GLOSSARY

Terms defined in the report are not included in this section.

Anolyte - In a two-solution electrolytic cell, the plating solution at the anode that is relatively exhausted and being replaced by the incoming cell feed. It is usually acidic.

Blowdown - A relatively small bleedoff discharge, continuous or periodic, from a recirculated closed system.

Catholyte - In a two-solution electrolytic cell, the incoming cell feed containing a relatively high concentration of the metal to be plated on the cathode.

Clarification - The process of removing undissolved materials from a liquid by settling or filtration.

Coagulant - A substance that enhances the aggregation of undissolved suspended matter.

Electrodeposition - The deposition of metal on the cathode induced by a low-voltage direct current.

Electrolytic Process - A low voltage direct current passes through an electrolyte containing metallic ions will cause the metallic ions to plate on the cathode as free metal atoms. The process is used to produce chromium and manganese metal, which are included with the ferroalloys. Chromium metal produced by this process is 99+ percent pure.

Flocculation - The aggregation of undissolved suspended matter into larger conglomerates.

Leach - The dissolution of matter from a multi-component solid mass, such as ore or slag, with an aqueous medium.

Polyelectrolyte - A substance (polymer) that enhances the flocculation mechanism.

Slag - A product resulting from the action of a flux on the non-metallic constituents of a processed ore, or on the oxidized metallic constituents.

TABLE 2

## CONVERSION FACTORS

Multiply (English Units)		by		To Obtain (Metric Units)	
English Unit	Abbreviation	Conversion	Abbreviation	Metric Unit	
acres	ac	0.405	ha	hectares	
acre-feet	ac ft	1233.5	cu m	cubic meters	
British Thermal Unit	BTU	0.252	kg cal	kilogram-calories	
British Thermal Unit/pound	BTU/lb	0.555	kg cal/kg	kilogram-calories/kilogram	
cubic feet/minute	cfm	0.028	cu m/min	cubic meters/minute	
cubic feet/second	cfs	1.7	cu m/min	cubic meters/minute	
cubic feet	cu ft	0.028	cu m	cubic meters	
cubic feet	cu ft	28.32	l	liters	
cubic inches	cu in	16.39	cu cm	cubic centimeters	
degree Fahrenheit	°F	0.555(°F-32) (a)	°C	degree Centigrade	
feet	ft	0.3048	m	meters	
gallon	gal	3.785	l	liters	
gallon/minute	gpm	0.0631	l/sec	liters/second	
horsepower	hp	0.7457	kw	kilowatts	
inches	in	2.54	cm	centimeters	
inches of Mercury	in Hg	0.03342	atm	atmospheres	
pounds	lb	0.454	kg	kilograms	
million gallons/day	mgd	3,785	cu m/day	cubic meters/day	
mile	mi	1.609	km	kilometer	
pound/square inch (gauge)	psig	(0.06805 psig +1) (a)	atm	atmospheres (absolute)	
square feet	sq ft	0.0929	sq m	square meters	
square inches	sq in	6.452	sq cm	square centimeters	
tons (short)	t	0.907	kkg	metric tons (1000 kilograms)	
yard	y	0.9144	m	meters	

(a) Actual conversion, not a multiplier