



# **Study of Selected Petroleum Refining Residuals**

---

---

## **Industry Study**

**STUDY OF SELECTED  
PETROLEUM REFINING RESIDUALS  
  
INDUSTRY STUDY**

Part 1

August 1996

U.S. ENVIRONMENTAL PROTECTION AGENCY  
Office of Solid Waste  
Hazardous Waste Identification Division  
401 M Street, SW  
Washington, DC 20460

# TABLE OF CONTENTS

Page Number

1.0	INTRODUCTION	1
1.1	BACKGROUND	1
1.2	OTHER EPA REGULATORY PROGRAMS IMPACTING THE PETROLEUM REFINING INDUSTRY	2
1.3	INDUSTRY STUDY FINDINGS	3
2.0	INDUSTRY DESCRIPTION	8
2.1	PETROLEUM REFINING INDUSTRY PROFILE	8
2.2	INDUSTRY STUDY	10
2.2.1	Site Selection	11
2.2.2	Engineering Site Visits	13
2.2.3	RCRA §3007 Questionnaire	13
2.2.4	Familiarization Sampling	14
2.2.5	Record Sampling	15
2.2.6	Split Samples Analyzed by API	20
2.2.7	Synthesis	20
3.0	PROCESS AND WASTE DESCRIPTIONS	21
3.1	REFINERY PROCESS OVERVIEW	21
3.2	CRUDE OIL DESALTING	25
3.2.1	Process Description	25
3.2.2	Desalting Sludge	26
3.3	HYDROCRACKING	34
3.3.1	Process Description	34
3.3.2	Spent Hydrocracking Catalyst	35
3.4	ISOMERIZATION	43
3.4.1	Isomerization Process Description	43
3.4.2	Isomerization Catalyst	46
3.4.3	Isomerization Treating Clay	54
3.5	EXTRACTION	58
3.5.1	Extraction Process Description	58
3.5.2	Extraction Treating Clay	59
3.6	ALKYLATION	66
3.6.1	Sulfuric Acid Alkylation Process Description	66
3.6.2	Hydrofluoric Acid Alkylation Process Description	67
3.6.3	Spent Treating Clay from Alkylation	69
3.6.4	Catalyst from Hydrofluoric Acid Alkylation	75
3.6.5	Acid Soluble Oil from Hydrofluoric Acid Alkylation	77
3.7	POLYMERIZATION	82
3.7.1	Process Descriptions	82
3.7.2	Spent Phosphoric Acid Polymerization Catalyst	84
3.7.3	Spent Dimersol Polymerization Catalyst	87
3.8	RESIDUAL UPGRADING	92
3.8.1	Process Descriptions	92
3.8.2	Off-specification Product from Residual Upgrading	96

3.8.3	Process Sludge from Residual Upgrading	97
3.9	LUBE OIL PROCESSING	103
3.9.1	Process Descriptions	103
3.9.2	Treating Clay from Lube Oil Processing	107
3.10	H <sub>2</sub> S REMOVAL AND SULFUR COMPLEX	112
3.10.1	Process Description	112
3.10.2	Off-Specification Product from Sulfur Complex and H <sub>2</sub> S Removal Facilities	117
3.10.3	Off-Specification Treating Solution from Sulfur Complex and H <sub>2</sub> S Removal Facilities	124
3.11	CLAY FILTERING	132
3.11.1	Process Description	132
3.11.2	Treating Clay from Clay Filtering	134
3.12	RESIDUAL OIL TANK STORAGE	142
3.12.1	Residual Oil Storage Tank Sludge	142

## LIST OF TABLES

Page Number

Table 1.1.	Petroleum Refining Residuals Identified in the EDF/EPA Consent Decree . . . . .	2
Table 1.2.	Overview of 15 Study Residuals of Concern as Managed in 1992 . . . . .	5
Table 2.1.	Engineering Site Visit Facilities . . . . .	12
Table 2.2.	Study Residuals Volume Statistics . . . . .	15
Table 2.3.	Residuals Collected for Record Analysis . . . . .	16
Table 2.4.	Descriptions of Samples Collected for Record Analysis . . . . .	17
Table 3.2.1.	Generation Statistics for Desalting Sludge, 1992 . . . . .	27
Table 3.2.2.	Desalter Sludge: Physical Properties . . . . .	30
Table 3.2.3.	Desalting Sludge Record Sampling Locations . . . . .	30
Table 3.2.4.	Desalting Sludge Characterization . . . . .	31
Table 3.3.1.	Generation Statistics for Hydrocracking Catalyst, 1992 . . . . .	37
Table 3.3.2.	Hydrocracking Catalyst Physical Properties . . . . .	38
Table 3.3.3.	Spent Hydrocracking Catalyst Record Sampling Locations . . . . .	39
Table 3.3.4.	Spent Hydrocracking Catalyst Characterization . . . . .	40
Table 3.4.1.	Generation Statistics for Catalyst from Isomerization, 1992 . . . . .	48
Table 3.4.2.	Catalyst from Isomerization: Physical Properties . . . . .	49
Table 3.4.3.	Spent Isomerization Catalyst Record Sampling Locations . . . . .	49
Table 3.4.4.	Residual Characterization Data for Spent Isomerization Catalyst . . . . .	51
Table 3.4.5.	Generation Statistics for Treating Clay from Isomerization, 1992 . . . . .	55
Table 3.4.6.	Treating Clay from Isomerization: Physical Properties . . . . .	57
Table 3.4.7.	Isomerization Spent Sorbent Record Sampling Locations . . . . .	57
Table 3.5.1.	Generation Statistics for Treating Clay from Extraction, 1992 . . . . .	61
Table 3.5.2.	Treating Clay from Extraction: Physical Properties . . . . .	63
Table 3.5.3.	Extraction Spent Sorbent Record Sampling Locations . . . . .	63
Table 3.5.4.	Residual Characterization Data for Spent Treating Clay from Extraction/Isomerization . . . . .	64
Table 3.6.1.	Generation Statistics for Treating Clay from Alkylation, 1992 . . . . .	70
Table 3.6.2.	Treating Clay from Alkylation: Physical Properties . . . . .	72
Table 3.6.3.	Alkylation Treating Clay Record Sampling Locations . . . . .	72
Table 3.6.4.	Alkylation Treating Clay Characterization . . . . .	73
Table 3.6.5.	Generation Statistics for Catalyst from HF Alkylation, 1992 . . . . .	76
Table 3.6.6.	Catalyst from HF Alkylation: Physical Properties . . . . .	76
Table 3.6.7.	Generation Statistics for Acid Soluble Oil, 1992 . . . . .	78
Table 3.6.8.	Acid Soluble Oil: Physical Properties . . . . .	79
Table 3.6.9.	Acid Soluble Oil Record Sampling Locations . . . . .	79
Table 3.6.10.	Acid Soluble Oil Characterization . . . . .	80
Table 3.7.1.	Generation Statistics for Phosphoric Acid Catalyst from Polymerization, 1992 . . . . .	85
Table 3.7.2.	Phosphoric Acid Catalyst from Polymerization: Physical Properties . . . . .	86
Table 3.7.3.	Phosphoric Acid Polymerization Catalyst Record Sampling Locations . . . . .	86
Table 3.7.4.	Generation Statistics for Spent Dimersol Polymerization Catalyst, 1992 . . . . .	88

Table 3.7.5.	Spent Dimersol Polymerization Catalyst Physical Properties . . . . .	89
Table 3.7.6.	Dimersol Polymerization Catalyst Record Sampling Locations . . . . .	89
Table 3.7.7.	Polymerization Catalyst Characterization . . . . .	90
Table 3.8.1.	Generation Statistics for Off-Specification Product from Residual Upgrading, 1992 . . . . .	96
Table 3.8.2.	Off-Specification Product from Residual Upgrading: Physical Properties . . . . .	97
Table 3.8.3.	Generation Statistics for Process Sludge from Residual Upgrading, 1992 . . . . .	98
Table 3.8.4.	Process Sludge from Residual Upgrading: Physical Properties . . . . .	100
Table 3.8.5.	Process Sludge from Residual Upgrading Record Sampling Locations . . . . .	100
Table 3.8.6.	Process Sludge from Residual Upgrading Characterization . . . . .	101
Table 3.9.1.	Generation Statistics for Treating Clay from Lube Oil, 1992 . . . . .	108
Table 3.9.2.	Treating Clay from Lube Oil: Physical Properties . . . . .	109
Table 3.9.3.	Treating Clay from Lube Oil Processing Record Sampling Locations . . . . .	109
Table 3.9.4.	Treating Clay from Lube Oil Processing Characterization . . . . .	110
Table 3.10.1.	Sulfur Removal Technologies Reported in RCRA §3007 Questionnaire . . . . .	112
Table 3.10.2.	Generation Statistics for Off-Spec Sulfur, 1992 . . . . .	119
Table 3.10.3.	Off-Specification Sulfur: Physical Properties . . . . .	121
Table 3.10.4.	Off-Specification Sulfur Record Sampling Locations . . . . .	121
Table 3.10.5.	Residual Characterization Data for Off-Specification Sulfur . . . . .	122
Table 3.10.6.	Generation Statistics for Spent Amine for H <sub>2</sub> S Removal, 1992 . . . . .	125
Table 3.10.7.	Generation Statistics for Stretford Solution for H <sub>2</sub> S Removal, 1992 . . . . .	126
Table 3.10.8.	Spent Amine: Physical Properties . . . . .	127
Table 3.10.9.	Spent Stretford Solution: Physical Properties . . . . .	128
Table 3.10.10.	Off-Specification Treating Solution Record Sampling Locations . . . . .	128
Table 3.10.11.	Characterization Data for Off-Specification Treating Solution from Sulfur Complex and H <sub>2</sub> S Removal . . . . .	130
Table 3.11.1.	Generation Statistics for Treating Clay from Clay Filtering, 1992 . . . . .	136
Table 3.11.2.	Treating Clay from Clay Filtering: Physical Properties . . . . .	137
Table 3.11.3.	Treating Clay Record Sampling Locations . . . . .	137
Table 3.11.4.	Residual Characterization Data for Treating Clay . . . . .	139
Table 3.12.1.	Generation Statistics for Residual Oil Tank Sludge, 1992 . . . . .	144
Table 3.12.2.	Residual Oil Tank Sludge: Physical Properties . . . . .	146
Table 3.12.3.	Residual Oil Tank Sludge Record Sampling Locations . . . . .	146
Table 3.12.4.	Residual Oil Tank Sludge Characterization . . . . .	147

## LIST OF FIGURES

Page Number

Figure 2.1.	Geographical Distribution of U.S. Refineries . . . . .	9
Figure 3.1.	Simplified Refinery Process Flow Diagram . . . . .	22
Figure 3.2.1.	Desalting Process Flow Diagram . . . . .	25
Figure 3.3.1.	Hydrocracking Process Flow Diagram . . . . .	35
Figure 3.4.1.	Isomerization Process Flow Diagram . . . . .	43
Figure 3.5.1.	Extraction Process Flow Diagram . . . . .	58
Figure 3.6.1.	H <sub>2</sub> SO <sub>4</sub> Alkylation Process Flow Diagram . . . . .	66
Figure 3.6.2.	HF Alkylation Process Flow Diagram . . . . .	68
Figure 3.7.1.	Process Flow Diagram for Phosphoric Acid Polymerization Process . . . . .	83
Figure 3.7.2.	Dimersol Polymerization Process Flow Diagram . . . . .	84
Figure 3.8.1.	Solvent Deasphalting Process Flow Diagram . . . . .	93
Figure 3.8.2.	Asphalt Oxidation Process Flow Diagram . . . . .	94
Figure 3.8.3.	Supercritical Extraction Process Flow Diagram . . . . .	95
Figure 3.9.1.	Lube Oil Processing Flow Diagram . . . . .	104
Figure 3.10.1.	Amine Sulfur Removal Process Flow Diagram . . . . .	113
Figure 3.10.2.	Claus Sulfur Recovery Process Flow Diagram . . . . .	114
Figure 3.10.3.	SCOT <sup>®</sup> Tail Gas Sulfur Removal Process Flow Diagram . . . . .	115

## 1.0 INTRODUCTION

### 1.1 BACKGROUND

The U.S. Environmental Protection Agency (EPA) is directed in section 3001(e)(2) of the Resource Conservation and Recovery Act (RCRA) (42 U.S.C. §6921 (e)(2)) to determine whether to list as hazardous wastes a number of different wastes including those of the petroleum refining industry. A lawsuit by the Environmental Defense Fund (EDF) in 1989 resulted in a consent decree approved by the court, that sets out an extensive series of deadlines for making the listing determinations required by Section 3001 (e)(2). The deadlines include those for making final listing determinations as well as for concluding various related studies or reports on the industries of concern. With respect to the refining industry, the consent decree identifies 14 specific residuals for which the Agency must make listing determinations and an additional 15 residuals for which the Agency must conduct a study. These 29 residuals, subsequently referred to as the Residuals of Concern (RCs), are listed in Table 1.1. As a result of the consent decree, the Agency embarked on a project to determine whether these 29 RCs pose a threat to human health and the environment and to develop a basis for making such a determination. As a result of the preliminary evaluation of the waste subject to the listing determination, EPA proposed a rule in which eleven wastes were not to be listed and three wastes were to be listed as hazardous wastes: K169, K170, and K171 (clarified slurry oil storage tank sediments and/or filter/separation solids from catalytic cracking, catalyst from hydrotreating, and catalyst from hydrorefining, respectively) (60 *FR* 57747, November 20, 1995). The final determination will be issued under the applicable terms of the consent decree. This report is the result of the Agency's study of the remaining 15 residuals.

The Petroleum Refining Industry was previously studied by OSW in the 1980s. This original effort involved sampling and analysis of a number of residuals at 19 sites, distribution of a RCRA §3007 questionnaire to 180 refineries (characterizing the industry as of 1983), and, ultimately, a listing determination effort focused on wastewater treatment sludges, culminating in the promulgation of hazardous waste listings F037 and F038 (respectively, primary and secondary oil/water/solids separation sludges from petroleum refining).

As part of the Agency's current investigation of residuals from petroleum refining, the Agency conducted engineering site visits at 20 refineries to gain an understanding of the present state of the industry. These 20 refineries were randomly selected from the 185 refineries operating in the continental United States in 1992. Familiarization samples of various residuals were collected at 3 of the 20 refineries to obtain data on the nature of the RCs and to identify potential problems with respect to future analysis. The Agency then conducted record sampling and analysis of the RCs. During the record sampling timeframe, an additional 6 facilities were randomly selected to increase sample availability. Approximately 100 record samples were collected and analyzed. Concurrently, the Agency developed, distributed and evaluated a RCRA §3007 survey to the 180 refineries in the U.S.



**Table 1.1. Petroleum Refining Residuals Identified in the EDF/EPA Consent Decree**

**Listing Residuals**

Clarified slurry oil sludge from catalytic cracking  
Unleaded storage tank sludge  
Crude storage tank sludge  
Process sludge from sulfur complex and H<sub>2</sub>S removal facilities (sulfur complex sludge)  
Sludge from HF alkylation  
Sludge from H<sub>2</sub>SO<sub>4</sub> alkylation  
Catalyst from catalytic hydrotreating  
Catalyst from catalytic reforming  
Catalyst and fines from catalytic cracking (FCC catalyst and FCC fines)  
Catalyst from catalytic hydrorefining  
Catalyst from H<sub>2</sub>SO<sub>4</sub> alkylation  
Catalyst from sulfur complex and H<sub>2</sub>S removal facilities (Claus and tail gas treating catalysts)  
Off-spec product and fines from thermal processes (Off-spec coke and fines)  
Spent caustic from liquid treating

**Study Residuals**

Desalting sludge from crude desalting  
Residual oil storage tank sludge  
Process sludge from residual upgrading  
Catalyst from extraction/isomerization processes\*  
Catalyst from catalytic hydrocracking  
Catalyst from polymerization  
Catalyst from HF alkylation  
Off-spec product and fines from residual upgrading  
Off-spec product from sulfur complex and H<sub>2</sub>S removal facilities (Off-spec sulfur)  
Off-spec treating solution from sulfur complex and H<sub>2</sub>S removal facilities (Spent amine and spent Stretford solution)  
Acid-soluble oil from HF alkylation (ASO)  
Treating clay from clay filtering  
Treating clay from lube oil processing  
Treating clay from the extraction/isomerization process  
Treating clay from alkylation

\*As described in Section 3.5 Extraction, catalyst used for extraction does not exist. The Agency believes it has been classified as a residual of concern inappropriately based on erroneous old data. Therefore, only catalyst from isomerization will be discussed in this study.

## **1.2 OTHER EPA REGULATORY PROGRAMS IMPACTING THE PETROLEUM REFINING INDUSTRY**

Each of EPA's major program offices has long-standing regulatory controls tailored to the petroleum refining industry. Some of the more significant programs with some relevance to OSW's listing determinations and industry study include:

- The Clean Air Act's Benzene National Emissions Standards for Hazardous Air Pollutants (NESHAPS), designed to control benzene releases from process and waste management units.

- The Clean Air Act's National Ambient Air Quality Standards (NAAQS), which prescribe limits for sulfur oxides (SO<sub>x</sub>), carbon monoxide (CO), particulates, nitrogen oxides (NO<sub>x</sub>), volatile organic compounds (VOCs), and ozone.
- The Clean Air Act's NESHAPs for Petroleum Refineries (40 CFR Part 63, Subpart CC, see 60 *FR* 43244, August 18, 1995), designed to control hazardous air pollutants (HAPs).
- The Clean Water Act sets specific technology-based limits and water quality-based standards for discharges to surface waters and publically-owned treatment works (POTWs) including standards designed specifically for discharges from the petroleum refining industry.
- The Toxicity Characteristic, particularly for benzene, in combination with the F037/F038 sludge listings, has had a significant impact on the industry's wastewater treatment operations, forcing closure of many impoundments and redesign of tank-based treatment systems.
- The Land Disposal Restrictions (LDR) Program, including the ongoing Phase III and IV development work.

### **1.3 INDUSTRY STUDY FINDINGS**

This document describes EPA's approach to conducting the industry study required by the EDF/EPA consent decree. The consent decree requires that EPA “fully characterize” the study residuals and how they are managed. “The report shall include a discussion of the concentration of toxic constituents in each waste, the volume of each waste generated, and the management practices for each waste (including plausible mismanagement practices).”

The statutory definition of “hazardous waste” is waste that may cause harm or pose a hazard to human health or the environment “when improperly treated, stored, transported, or disposed of, or otherwise managed.”

To implement this section of the statute, EPA considers available information on current management practices, and also exercises judgment as to plausible ways the waste could be managed in addition to those practices actually reported. EPA then judges which management practices have the potential to pose the greatest risk to human health or the environment and those practices would be assessed in a risk assessment.

As EPA explained in the preamble to the dyes and pigments proposed listing [59 *FR* 66072], EPA generally assumes that placement in an unlined landfill is a reasonably plausible management scenario for solids that potentially poses significant risks and thus would be “mismanagement” that should be examined by further risk assessment. For liquid wastes, unlined surface impoundments are such a presumptive mismanagement scenario. In past risk assessment work, EPA has found that these two scenarios are generally the scenarios most likely to pose a risk to ground water and thus would be mismanagement scenarios for a hazardous waste. In some cases, EPA has also found it appropriate to examine waste piles for solids prone

to transport by wind or erosion and to look at an aerated tank for volatile hazardous constituents in waste waters.

EPA also considers other scenarios, such as land application without Federal regulatory controls, as possible mismanagement scenarios and, where there is evidence that such practices occur for a particular waste stream, would consider whether further evaluation is appropriate. If EPA determines that a presumptive mismanagement scenario, such as disposal in an unlined surface impoundment, does not occur and would not reasonably be expected to occur, EPA may consider it implausible and instead use a more likely scenario as the plausible mismanagement scenario for subsequent analysis.

In the recent proposal to list petroleum residuals, EPA found the following waste management practices to pose the greatest risk and be the basis for judging whether these wastes posed a potential risk to human health or the environment when mismanaged:

- Unlined landfills
- Unlined surface impoundments
- Land application units not subject to Federal regulations

With respect to the residuals in this study, EPA found that the following management practices and their associated residuals (see Table 1.2) were reported and thus would be mismanagement scenarios EPA would further evaluate to ascertain if there were a potential risk:

- **Unlined landfills**
  - Residual oil storage tank sludge
  - Process sludge from residual upgrading
  - Catalyst from catalytic hydrocracking
  - Catalyst from polymerization
  - Off-spec product from sulfur complex and H<sub>2</sub>S removal facilities (off-spec sulfur)
  - Off-spec treating solution from sulfur complex and H<sub>2</sub>S removal facilities (spent amine and spent Stretford solution)

**Table 1.2. Overview of 15 Study Residuals of Concern as Managed in 1992**

Management Practice	Residuals of Concern: Study Residuals																TOTALS MT	Percent of Total
	ASO mt	Isom Catalyst mt	HF Catalyst mt	Polymer Catalyst mt	Desalting Sludge mt	Hydro- Cracking Catalyst mt	Off-spec Prod. Resid Upgrading mt	Off-spec Sulfur Product mt	Sludge Resid Upgrad mt	Resid Oil Tank Sludge mt	Off-spec Treating Solution mt	Treating Clay Alkylation mt	Treating Clay Clay Filter mt	Treat Clay Isom/ Extract mt	Treating Clay from Lube Oil mt			
<b>DISPOSAL</b>																		
Disposal offsite Subtitle D landfill				1,429	29	1,593		5,043	138	6,458	200	634	3,641	937	37	20,138	16.8%	
Disposal offsite Subtitle C landfill		44		65	221	992		3,576	0	622	39	24	1,735	516	79	7,913	6.6%	
Disposal onsite Subtitle C landfill				349				289	62	4		67	52	58	5	886	0.7%	
Disposal onsite Subtitle D landfill				256	102			226	7	30	711	626	1,032	496		3,485	2.9%	
Disposal onsite or offsite underground injection					2						673					675	0.6%	
Storage or disposal onsite surface impoundment	0									132	1					133	0.1%	
Other disposal onsite/roadbed mixing									0			4	16	138		158	0.1%	
Use as cover in onsite landfill										7						7	0.0%	
Use as cap for onsite landfarm, fill material, or vent													20			20	0.0%	
<b>TOTAL DISPOSED</b>	<b>0</b>	<b>44</b>	<b>0</b>	<b>2,099</b>	<b>354</b>	<b>2,584</b>	<b>0</b>	<b>9,133</b>	<b>207</b>	<b>7,254</b>	<b>1,624</b>	<b>1,355</b>	<b>6,497</b>	<b>2,145</b>	<b>120</b>	<b>33,417</b>	<b>27.9%</b>	
<b>DISCHARGED</b>																		
Discharge to onsite wastewater treatment facility	1,258				128				3	47	205	0	7			1,648	1.4%	
Discharge to POTW					647				1		0					648	0.5%	
Discharge to surface water under NPDES	3,600		152		1,266						6,849		507			12,374	10.3%	
Discharge to offsite POTW											1,566					1,566	1.3%	
<b>TOTAL DISCHARGED</b>	<b>3,600</b>	<b>0</b>	<b>152</b>	<b>0</b>	<b>1,913</b>	<b>0</b>	<b>0</b>	<b>0</b>	<b>1</b>	<b>0</b>	<b>8,415</b>	<b>0</b>	<b>507</b>	<b>0</b>	<b>0</b>	<b>14,588</b>	<b>12.2%</b>	
<b>RECOVERED, RECYCLED, REUSED, REGENERATED</b>																		
<b>Metals Reclamation</b>																		
Transfer metal catalyst for reclamation or regeneration		293									5,127	91	89	33		18,819	15.7%	
<b>Recycle to Processes</b>																		
Recovery onsite via distillation, coker, or cat cracker	50							0	16	310						376	0.3%	
Onsite reuse													20			20	0.0%	
Other recycling, reclamation or reuse/sulfur recov. unit								2			13					15	0.0%	
Recovery onsite in catalytic cracker	3,641									0	1,150					4,791	4.0%	
Recovery onsite in coker	1,019			749	52					0			20			1,840	1.5%	
Other recovery onsite/alkyl	1,300															1,300	1.1%	
Other recovery onsite/hydroprocessing	510															510	0.4%	
Other recovery onsite/reuse in extraction process								800								800	0.7%	
<b>Miscellaneous On-site Recycling</b>																		
Reuse onsite as replacement catalyst for another unit						159										159	0.1%	
Other recovery onsite	370														354	724	0.6%	
Other recycling, reclamation or reuse/offsite reuse												30	38			68	0.1%	
Other recycling, reclamation or reuse/cement plant												771	161	28	249	1,210	1.0%	
<b>TOTAL RECYCLED</b>	<b>6,890</b>	<b>293</b>	<b>0</b>	<b>749</b>	<b>52</b>	<b>13,345</b>	<b>800</b>	<b>2</b>	<b>16</b>	<b>310</b>	<b>6,290</b>	<b>892</b>	<b>329</b>	<b>62</b>	<b>603</b>	<b>30,633</b>	<b>25.6%</b>	
<b>STORAGE</b>																		
Storage in pile				0								30	128	20		178	0.1%	
<b>TOTAL STORED (interim)</b>	<b>0</b>	<b>0</b>	<b>0</b>	<b>0</b>	<b>0</b>	<b>0</b>	<b>0</b>	<b>0</b>	<b>0</b>	<b>0</b>	<b>0</b>	<b>30</b>	<b>128</b>	<b>20</b>	<b>0</b>	<b>178</b>	<b>0.1%</b>	

**Table 1.2. Overview of 15 Study Residuals of Concern as Managed in 1992 (continued)**

Management Practice	Residuals of Concern: Study Residuals															TOTALS MT	Percent of Total
	ASO mt	Isom Catalyst mt	HF Catalyst mt	Polymer Catalyst mt	Desalting Sludge mt	Hydro- Cracking Catalyst mt	Off-spec Prod. Resid Upgrading mt	Off-spec Sulfur Product mt	Sludge Resid Upgrad mt	Resid Oil Tank Sludge mt	Off-spec Treating Solution mt	Treating Clay Alkylation mt	Treating Clay Clay Filter mt	Treat Clay Isom/ Extract mt	Treating Clay from Lube Oil mt		
<b>TRANSFER</b>																	
Transfer of acid or caustic for recycle, reuse, reclamation										2,475							
Transfer for use as ingredient in products placed on land				543				15		35			176			768	
Transfer to N.O.S. offsite entity and final management								0	0					14		14	
Transfer to another petroleum refinery						2,100				927						3,027	
Transfer for direct use as a fuel or to make a fuel	741				1,938								95			2,773	
Transfer with coke product or other refinery product	3,731							7	5				5			3,747	
Transfer to other offsite entity/carbon regeneration													54			54	
Transfer to other offsite entity/amine reclaimer										166						166	
Transfer to other offsite entity/alumina manufacturer												405				405	
Transfer to other offsite entity/smelter												155				155	
Transfer to other offsite entity/used as a raw material feed								488								488	
<b>TOTAL TRANSFERRED</b>	<b>4,472</b>	<b>0</b>	<b>0</b>	<b>543</b>	<b>1,938</b>	<b>2,100</b>	<b>0</b>	<b>509</b>	<b>5</b>	<b>962</b>	<b>2,641</b>	<b>560</b>	<b>329</b>	<b>14</b>	<b>0</b>	<b>14,073</b>	
<b>TREATMENT</b>																	
Evaporation*													8			8	
Bioremediation*													21			21	
Neutralization	11,388	0		0							0					11,388	
Offsite incineration, stabilization, or reuse	0			0	56			1	9				42			108	
Onsite boiler	2,610										9					2,619	
Onsite industrial furnace	3,274															3,274	
Onsite land treatment				728	346					530		59	923	231	10	2,827	
Offsite land treatment					53			1		4			198			256	
<b>TOTAL TREATED (interim)</b>	<b>17,272</b>	<b>0</b>	<b>0</b>	<b>728</b>	<b>455</b>	<b>0</b>	<b>0</b>	<b>2</b>	<b>9</b>	<b>534</b>	<b>9</b>	<b>59</b>	<b>1,193</b>	<b>231</b>	<b>10</b>	<b>20,502</b>	
<b>GRAND TOTAL</b>	<b>33,493</b>	<b>337</b>	<b>152</b>	<b>4,119</b>	<b>4,841</b>	<b>18,029</b>	<b>800</b>	<b>9,647</b>	<b>242</b>	<b>9,107</b>	<b>23,881</b>	<b>2,895</b>	<b>8,990</b>	<b>2,471</b>	<b>733</b>	<b>119,738</b>	
	<b>28.0%</b>	<b>0.3%</b>	<b>0.1%</b>	<b>3.4%</b>	<b>4.0%</b>	<b>15.1%</b>	<b>0.7%</b>	<b>8.1%</b>	<b>0.2%</b>	<b>7.6%</b>	<b>19.9%</b>	<b>2.4%</b>	<b>7.5%</b>	<b>2.1%</b>	<b>0.6%</b>		

\* To avoid double counting, these intermediate steps were not included in the total.

- Treating clay from clay filtering
  - Treating clay from lube oil processing
  - Treating clay from the extraction/isomerization process
  - Treating clay from alkylation
- **Unlined surface impoundments**
    - Residual oil storage tank sludge
    - Off-spec treating solution from sulfur complex and H<sub>2</sub>S removal facilities (spent amine and spent Stretford solution)
- **Land application not subject to Federal regulations**
    - Residual oil storage tank sludge
    - Catalyst from polymerization
    - Off-spec product from sulfur complex and H<sub>2</sub>S removal facilities (off-spec sulfur)
    - Treating clay from clay filtering
    - Treating clay from lube oil processing
    - Treating clay from the extraction/isomerization process
    - Treating clay from alkylation

In addition, EPA found that the management practice of mixing of treating clays with roadbed materials for onsite use was reported and would merit evaluation as a potential mismanagement scenario.

Section 2.0 provides an overview of the petroleum refining industry and EPA's approach to this study. The fifteen study residuals identified in the consent decree accounted for approximately 120,000 metric tons in 1992, compared to over 3.1 million metric tons of listing residuals generated in 1992. Table 1.2 provides a description of the 15 study residuals by management practice and volume generated. The Agency believes that the management practices reported consist of virtually all of the plausible management practices to which the residuals may be subjected. Section 3.0 describes the refinery processes associated with generating the consent decree residuals of concern and detailed characterization of each of the study residuals as required by the consent decree.

## 2.0 INDUSTRY DESCRIPTION

### 2.1 PETROLEUM REFINING INDUSTRY PROFILE

In 1992<sup>1</sup>, the U.S. petroleum refining industry consisted of 185 refineries (of which 171 were fully active during the year) owned by 91 corporations. Atmospheric crude oil distillation capacity totaled 15,120,630 barrels per calendar day (bpcd) (DOE, 1993). As of January 1, 1996, U.S. capacity totaled 15,341,000 bpcd, showing little change in the Nation's refining capacity since the Agency's baseline year. Figure 2.1 illustrates the distribution of refineries across the country. Refineries can be classified in terms of size and complexity of operations. Forty-four percent of the refineries operating in 1992 processed less than 50,000 barrels per day of crude, while the 20 largest companies account for 77 percent of the nation's total refining capacity.

The simplest refineries use distillation to separate gasoline or lube oil fractions from crude, leaving the further refining of their residuum to other refineries or for use in asphalt. Approximately 18 percent of the U.S.'s refineries are these simple topping, asphalt, or lube oil refineries. More sophisticated refineries will have thermal and/or catalytic cracking capabilities, allowing them to extract a greater fraction of gasoline blending stocks from their crude. The largest refineries are often integrated with chemical plants, and utilize the full range of catalytic cracking, hydroprocessing, alkylation and thermal processes to optimize their crude utilization. Section 3.1 describes the major unit operations typically found in refining operations.

The refining industry has undergone significant restructuring over the past 15 years. Much of this restructuring has been in response to the price allocation programs of the 1970s and industry deregulation in the 1980s. While the total national refining capacity dropped 17 percent since 1980 to 15 million barrels per day, the number of refineries dropped 45 percent from 311 in 1980 to approximately 171 active in 1992 (and 169 as of 1/1/96). Refinery utilization rates over the 1980 to 1992 period rose from 75 percent to 90 percent. (API, 1993). Very few new refineries have been constructed in the past decade; the industry instead tends to focus on expansions of existing plants.

The facilities closed tended to be smaller, inefficient refineries. Larger existing facilities with capacities over 100,000 bbl/day have increased production to off-set the facility closings.

The data presented above indicates that the petroleum refining industry has been going through a consolidation, which has resulted in a large decrease in the number of refineries in the United States, but only a slight decrease in production. It is expected that this trend will

---

<sup>1</sup>The Agency conducted its industry-wide survey in 1993-1994, characterizing residual generation in 1992. Thus, 1992 was considered the Agency's baseline year. The Agency has no reason to conclude that 1992 was not representative of industry management practices. EPA's risk assessment modeling used as input the 1992 data for the RCs as a "snap shot" of the industry's management practices. However, information for years other than 1992 is provided in the pertinent sections of the study.

Figure 2.1. Geographical Distribution of U.S. Refineries

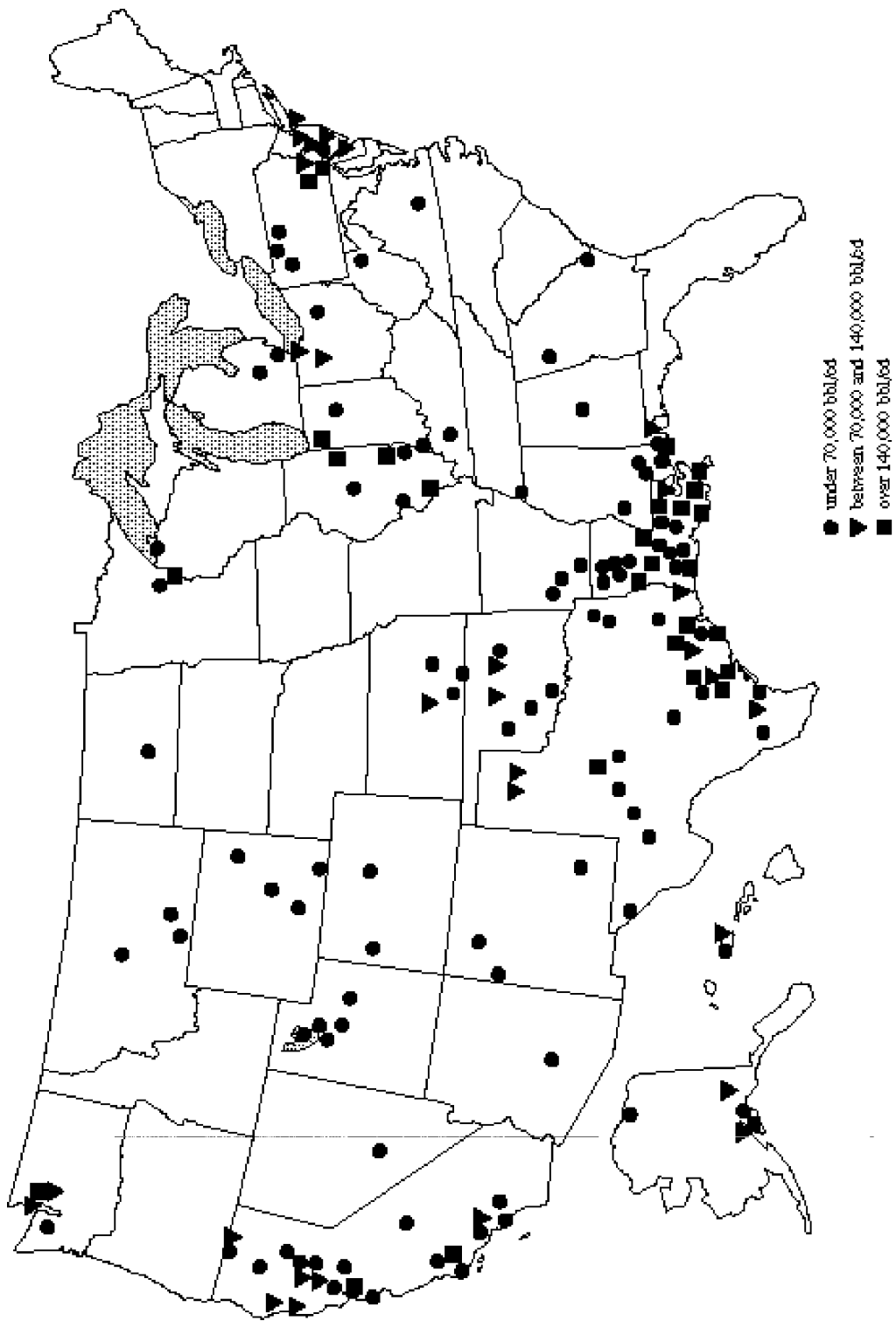



continue, with refineries continuing to close, but expansions occurring at others, keeping the total refinery capacity in line with demand for refinery products.

In addition to restructuring, the industry is adding and changing production operations. Many of these process changes are being implemented as a result of two factors: (1) today's crudes tend to be heavier and contain higher levels of sulfur and metals, requiring process modifications, and (2) a series of important pollution control regulations have been implemented, including new gasoline reformulation rules designed to reduce the amount of volatile components in gasoline, and new regulations requiring low-sulfur diesel fuels. These heavier crudes and new rules have caused refineries to make process modifications to their gasoline production units such as catalytic cracker units, installing additional sulfur removal hydrotreaters, and constructing unit processes to manufacture additives such as oxygenates.

Many of the process modifications in response to the reformulated gasoline and low sulfur diesel fuels have been implemented since 1992. The **Oil and Gas Journal** (December, 1993, 1994, and 1995) reports the following major processing capacity changes from year end 1992 to year end 1995:

- 5.5 percent capacity increase in thermal operations (forecast to further increase by new construction scheduled to be completed in 1996)
- 8.7 percent capacity increase in hydrocracking operations
- 9.8 percent capacity increase in combined hydrorefining and hydrotreating operations (there was a 16 percent increase in hydrotreating capacity offset by a 12 percent decrease in hydrorefining capacity).
- 13.8 percent increase in aromatic and isomerization unit capacity.
- 5.6 percent increase in alkylation capacity
- 11.3 percent increase in lube production capacity
- 7.7 percent decrease in asphalt production
- Small capacity increases for crude distillation, reforming, and catalytic cracking (increases of 0.9, 0.7, and 1.6 percent, respectively).

## 2.2 INDUSTRY STUDY

OSW's current listing determination and industry study for the petroleum refining industry has been underway since 1992 and can be characterized in terms of two major avenues for information collection: field work and survey evaluation. As part of the Agency's field work, site selection, engineering site visits, familiarization sampling, and record sampling were conducted. The survey effort included the development, distribution, and assessment of an extensive industry-wide RCRA §3007 survey. Each of these elements is described further below, reflecting the relative order in which these activities were conducted.

### 2.2.1 Site Selection

EPA's field work activities were focussed on a limited number of refineries, allowing the Agency to establish strong lines of communication with the selected facilities, and maximizing efficiency of information collection. After considering logistical and budgetary constraints, the Agency determined that it would limit its field work to 20 refineries.

The Agency defined a site selection procedure that was used in selecting the 20 site visits from the population of 185 domestic refineries in the continental U.S.. The objectives of the selection procedure were:

- to ensure that the characterization data obtained from residuals at the 20 selected facilities could be used to make valid, meaningful statements about those residuals industry-wide.
- to give the Agency first-hand exposure to both large and small refineries.
- to be fair to all domestic refineries.

The Agency chose to select facilities randomly rather than purposefully. Although a randomly selected group of refineries did not offer as many sampling opportunities as a hand-picked group (e.g., focusing on those larger refineries that generate most of the RCs), the Agency favored random selection because it did not require subjective input, and also because it lends itself to statistical analysis, which is useful in making general statements about the population of residuals.

The Agency broke the industry into two strata based on atmospheric distillation capacity and made random selections from each stratum independently. The high-capacity stratum (those with a crude capacity of 100,000 bpcd or greater) contains the top 30 percent of refineries, which together account for 70 percent of the refining industry's capacity. The stratification enables the Agency to weigh the selection toward the larger facilities on the basis that they produce larger volumes of residuals, and that they offer a larger number of residual streams per site visit. The Agency chose to select 12 of the 20 site visits, 60 percent, from the high-capacity stratum. The smaller facilities had a lower chance of being selected, but not as low as they would have if the likelihood of selection was based strictly on size. The selected facilities are presented in Table 2.1<sup>2</sup>.

---

<sup>2</sup>Upon initial contact with several of the randomly selected refineries, it was determined that they were inappropriate candidates for site visits because they had stopped operation and were not generating any residuals of interest to the Agency. Replacement facilities were then selected randomly from the same stratum.

The list of refineries slated for field investigations was expanded in June, 1994 to allow the Agency to fill out certain categories of samples that proved to be difficult to find in the field. The final list presented in Table 2.1 represents those refineries at which site visits actually occurred.

**Table 2.1. Engineering Site Visit Facilities**

<b>Refinery</b>	<b>Location</b>	<b>Initial Site Visit Date</b>
Amoco Oil	Texas City, Texas	March 29, 1993
Arco	Ferndale, Washington	June 9, 1993
Ashland	Canton, Ohio	May 24, 1993
Ashland	Catlettsburg, Kentucky	March 22, 1993
BP Oil	Belle Chasse, Louisiana	May 3, 1993
BP Oil	Toledo, Ohio	May 26, 1993
Chevron (purchased by Clark) <sup>1</sup>	Port Arthur, Texas	August 31, 1994
Chevron <sup>1</sup>	Salt Lake City, Utah	February 21, 1995
Conoco <sup>1</sup>	Commerce City, Colorado	To be determined
Exxon	Billings, Montana	June 9, 1993
Koch	St. Paul, Minnesota	May 19, 1993
Little America	Evansville, Wyoming	June 8, 1993
Marathon	Garyville, Louisiana	April 22, 1993
Murphy	Superior, Wisconsin	May 17, 1993
Pennzoil	Shreveport, Louisiana	May 5, 1993
Phibro Energy <sup>1</sup>	Houston, Texas	April 20, 1995
Rock Island (purchased by Marathon)	Indianapolis, Indiana	April 26, 1993
Shell	Deer Park, Texas	March 31, 1993
Shell	Norco, Louisiana	April 20, 1993
Shell	Wood River, Illinois	May 28, 1993
Star Enterprise <sup>1</sup>	Convent, Louisiana	August 30, 1994
Star Enterprise <sup>1</sup>	Port Arthur, Texas	September 21, 1994
Sun	Philadelphia, Pennsylvania	May 12, 1993
Texaco	Anacortes, Washington	June 10, 1993
Total	Ardmore, Oklahoma	June 23, 1993
Young	Douglasville, Georgia	June 21, 1993

<sup>1</sup>Refinery selected to augment record sample availability.

### **2.2.2 Engineering Site Visits**

The field activities were initiated with a series of engineering site visits to the selected facilities. The purpose of these trips was to:

- Develop a firm understanding of the processes associated with the RCs
- Understand how, when, why, and where each residual is generated and managed
- Establish a schedule of sampling opportunities
- Establish a dialogue with the refinery personnel to ensure optimal sampling and collection of representative samples.

An engineering site visit report was developed for each of the trips; these are available in the CBI and non-CBI dockets, as appropriate. For the later site visits conducted in 1994 and 1995, the engineering site visit reports were combined with the analytical data reports prepared for each facility. The site visit reports included the following elements:

- Purpose of the site visit
- Refinery summary, including general information gathered during the site visit, as well as data gleaned from telephone conversations and reviews of EPA files, the refinery's process flow diagram, and expected residual availability
- A discussion of the processes used at the refinery generating the residuals of concern
- Source reduction and recycling techniques employed by the refinery
- A description of onsite residual management facilities
- A chronology of the site visit.

### **2.2.3 RCRA §3007 Questionnaire**

EPA developed an extensive questionnaire under the authority of §3007 of RCRA for distribution to the petroleum refining industry. A blank copy of the survey instrument is provided in the RCRA docket. The questionnaire was organized into the following areas:

- I. Corporate and facility information
- II. Crude oil and product information
- III. Facility process flow diagram
- IV. Process units: general information
- V. Process units: flow diagrams and process descriptions
- VI. Residual generation and management
- VII. Residual and contaminated soil and debris characterization
- VIII. Residual management units: unit-specific characterization
- IX. Unit-specific media characterization

- X. General facility characterization (focusing on exposure pathway characterization)
- XII. Source reduction efforts
- XIII. Certification.

The survey was distributed in August 1993 to all refineries identified as active in 1992 in the DOE Petroleum Supply Annual. Of the 185 surveys distributed, completed responses were obtained for 172 refineries. Thirteen refineries notified EPA that they had stopped operations at some point in or after 1992 and thus were unable to complete the survey due to no staffing or inaccessible or unavailable data.

The survey responses were reviewed by SAIC chemical engineers for completeness and then entered into a relational data base known as the 1992 Petroleum Refining Data Base (PRDB). The entries were subjected to a series of automated quality assurance programs to identify inappropriate entries and missing data links. An exhaustive engineering review of each facility's response was then conducted, resulting in follow-up letters to most of the industry seeking clarifications, corrections, and additional data where needed. The responses to the followup letters were entered into the data base. A wide variety of additional quality assurance checks were run on the data to ensure that the residuals of concern were characterized as completely and accurately as possible. Follow-up telephone interviews were conducted as necessary to address remaining data issues. After extensive review, the Agency believes that the data are reliable and represent the industry's current residual generation and management practices.

Table 2.2 describes the survey results for each of the study residuals of concern, sorted by total volume generated in metric tons (MT).

#### **2.2.4 Familiarization Sampling**

The early phases of the analytical phase of this listing determination consisted of the development of a Quality Assurance Project Plan (QAPjP) for sampling and analysis, followed by the collection and analysis of six "familiarization" samples (five listing residuals and one study residual). The purpose of collecting these samples was to assess the effectiveness of the methods identified in the QAPjP for the analysis of the actual residuals of concern. Due to the high hydrocarbon content of many of the RCs, there was concern at the outset of the project that analytical interferences would prevent the contracted laboratory from achieving adequate quantitation limits; familiarization analysis allowed the laboratories to experiment with the analytical methods and waste matrices and optimize operating procedures.

In addition, the first version of the QAPjP identified a list of target analytes that was derived from previous Agency efforts to characterize refinery residuals. These included the Delisting Program's list of analytes of concern for refinery residuals, the "Skinner List", an evaluation of compounds detected in the sampling and analysis program for listing refinery residuals in the 1980s, and the judgment of EPA and SAIC chemists who evaluated the process chemistry of the residuals of concern. During familiarization sample analysis, particular attention was paid to the tentatively identified compounds to determine whether they should be added to the target analyte list.

**Table 2.2. Study Residuals Volume Statistics**

Study Residual Description	# of Reported Residuals	Total Volume (MT)
Acid Soluble Oil	80	33,493
Hydrocracking Catalyst	83	18,029
Off-specification Product from Sulfur Complex and H <sub>2</sub> S Removal	93	9,647
Residual Oil Tank Sludge	62	9,107
Treating Clay from Clay Filtering	244	8,990
Desalting Sludge	141	4,841
Off-specification Treating Solution from Sulfur Complex and H <sub>2</sub> S Removal (spent amine and spent Stretford solution)	76	23,881
Catalyst from Polymerization (phosphoric acid and Dimersol)	42	4,119
Treating Clay from Alkylation	88	2,895
Treating Clay from Isomerization/Extraction	43	2,472
Off-specification Product from Residual Upgrading	3	800
Treating Clay from Lube Oil	19	733
Catalyst from Isomerization	21	337
Sludge from Residual Upgrading	34	242
Catalyst from HF Alkylation	3	152
Total	1,061	119,738

Samples of five listing residuals were collected for familiarization analysis: crude oil tank sediments, hydrotreating catalyst, sulfur complex sludge, H<sub>2</sub>SO<sub>4</sub> alkylation catalyst, and spent caustic. One study residual, acid soluble oil, was analyzed under this program. The results of the familiarization effort essentially confirmed the techniques identified in the QAPjP and indicated that the laboratories generally would be able to achieve adequate quantitation of the target analytes. The familiarization and final QAPjPs are provided in the docket to the November 20, 1995 proposed rulemaking.

### 2.2.5 Record Sampling

Upon completion of the familiarization sampling and analysis effort, the Agency initiated record sampling and analysis of the listing and study residuals. Given budgetary constraints, the Agency set a goal of collecting 4-6 samples of each of the listing residuals, and 2-4 samples of the study residuals for a total of 134 samples<sup>3</sup>. Table 2.3 shows the 103 samples that were actually collected. The numbers in the darkened boxes refer to Table 2.4 which lists each of the sample numbers, sample dates, facility names, and other information describing the residual samples.

---

<sup>3</sup>The Agency determined that one listing residual, catalyst from sulfuric acid alkylation, would not be sampled due to the existing regulatory exemption for sulfuric acid destined for reclamation, and that one study residual, catalyst from HF alkylation, could not be sampled due to its extremely rare generation.

**Table 2.3. Residuals Collected for Record Analysis**

Listing Residuals	Record Samples					
	1	2	3	4	5	6
Crude oil tank sludge	33	67	73	53	89	91
Unleaded gasoline tank sludge	34	42	65			
CSO sludge	14	49	72	88		
FCC catalyst and fines	1	12	13	26	27	28
Catalyst from hydrotreating	6	44	55	83	94	69
Catalyst from hydrorefining	21	36	85			
Catalyst from reforming	3	22	37	56	79	75
Sulfuric acid alkylation sludge	46					
HF alkylation sludge	19	47	51	74	96	
Sulfur complex sludge	10	25	29	80	70	
Catalyst from sulfur complex	9	15	23	24	52	54
Off-spec product & fines/thermal process	30	45	59	63	81	84
Spent caustic	16	17	32	62	64	95

Familiarization Samples
1
F5
F2
F3
F1

Study Residuals	1	2	3	4
Residual oil tank sludge	41	92		
Desalting sludge	5	50	90	102
Hydrocracking catalyst	4	43	87	
Catalyst from isomerization	39	48	71	97
Treating clay from isomerization/extraction	68	98		
Catalyst from polymerization	35	66A	66B	
Treating clay, alkylation (HF and H2SO4)	20	76	86	99
ASO	18	38	77	93
Off-spec sulfur product	2	8	40	100
Spent treating solution (amine)	61	58	82	78
Process sludge from residual upgrading	11			
Off-spec product, residual upgrading				
Treating clay from lube oil	60			
Treating clay from clay filtering	7	31	57	101

F4

Notes: Sulfuric Acid Alkylation catalyst is not presented in this figure. One familiarization sample of sulfuric acid catalyst was captured and analyzed. HF catalyst is constant boiling mixture (CBM) and is not shown in this figure.

The sampling team maintained monthly phone contact with the targeted refineries to maintain an optimized sampling schedule. Despite careful coordination with the refineries and best efforts to identify and collect all available samples, there were several categories of study residuals for which the targeted minimum number of samples could not be collected:

- Two samples of residual oil tank sludge were collected. This residual is available only for a brief period during tank turnarounds, which may occur only every 10 years. In several cases, refineries mixed their residual oil and clarified slurry oil (CSO) in the same tank.

**Table 2.4. Descriptions of Samples Collected for Record Analysis**

Petroleum Refining Industry Study

17

August 1996

Count	Residual Name	Sample Number	Sample Date	Notes	Refinery
1	FCC catalyst and fines	R2-FC-01	30-Sep-93	ESP Fines.	Shell, Wood River, Illinois
2	Off-spec sulfur	R2-SP-01	30-Sep-93	Taken from low spots on the unit.	Shell, Wood River, Illinois
3	Catalyst from reforming	R2-CR-01	01-Oct-93	Platinum catalyst.	Shell, Wood River, Illinois
4	Catalyst from hydrocracking	R2-CC-02	04-Oct-93	2nd stage, Ni/W.	Shell, Wood River, Illinois
5	Desalting sludge	R1-DS-01	26-Oct-93	Removed from vessel.	Marathon, Indianapolis
6	Catalyst from hydrotreating	R1-TC-01	26-Oct-93	Naphtha reformer pretreat, CoMo.	Marathon, Indianapolis
7	Treating clay	R1-CF-01	27-Oct-93	Kerosene.	Marathon, Indianapolis
8	Off-spec sulfur	R1-SP-01	27-Oct-93	From product tank.	Marathon, Indianapolis
9	Catalyst from sulfur complex	R1-SC-01	27-Oct-93	Al <sub>2</sub> O <sub>3</sub> .	Marathon, Indianapolis
10	Sulfur complex sludge	R1-ME-01	27-Oct-93	MEA reclaimer bottoms.	Marathon, Indianapolis
11	Process sludge from residual upgrading	R1-RU-01	27-Oct-93	ROSE butane surge tank sludge.	Marathon, Indianapolis
12	FCC catalyst and fines	R4-FC-01	16-Nov-93	Equilibrium cat. from hopper.	Little America, Evansville, Wy
13	FCC catalyst and fines	R4-FC-02	16-Nov-93	ESP fines. truck trailer comp.	Little America, Evansville, Wy
14	CSO sludge	R4-SO-01	16-Nov-93	Tank sludge from pad.	Little America, Evansville, Wy
15	Catalyst from sulfur complex	R4-SC-01	16-Nov-93	Claus unit alumina, super sack comp.	Little America, Evansville, Wy
16	Spent caustic	R3-LT-01	18-Nov-93	Tank samp. Cresylic, concentrated.	Exxon, Billings, Montana
17	Spent caustic	R3-LT-02	18-Nov-93	Tank samp. Sulfidic, concentrated.	Exxon, Billings, Montana
18	ASO	R3-AS-01	18-Nov-93	Non-neutralized, separator drum sample	Exxon, Billings, Montana
19	HF alkylation sludge	R3-HS-01	18-Nov-93	Not dewatered. Dredge from pit.	Exxon, Billings, Montana
20	Treating clay from alkylation	R3-CA-01	18-Nov-93	HF. Propane treater. Drum composite.	Exxon, Billings, Montana
21	Catalyst from hydrotreating	R5-TC-01	07-Feb-94	Heavy Gas Oil, CoMo	Marathon, Garyville, LA
22	Catalyst from reforming	R5-CR-01	07-Feb-94	CCR fines, Pt	Marathon, Garyville, LA
23	Catalyst from sulfur complex	R5-SC-01	07-Feb-94	Claus	Marathon, Garyville, LA
24	Catalyst from sulfur complex	R5-SC-02	07-Feb-94	Tail gas, CoMo	Marathon, Garyville, LA
25	Sulfur complex sludge	R5-ME-02,03	07-Feb-94	Refinery MDEA filter cartridge	Marathon, Garyville, LA
26	FCC catalyst and fines	R5-FC-02	07-Feb-94	Wet Scrubber Fines	Marathon, Garyville, LA
27	FCC catalyst and fines	R6-FC-01	09-Feb-94	Equil. from unit	Shell, Norco, LA
28	FCC catalyst and fines	R6-FC-02	09-Feb-94	Wet scrubber fines	Shell, Norco, LA
29	Sulfur complex sludge	R6-ME-01	09-Feb-94	Refinery DEA filter cartridge	Shell, Norco, LA
30	Off-spec product & fines from thermal process	R6-TP-01	09-Feb-94	Coke fines.	Shell, Norco, LA
31	Treating clay	R6-CF-01	09-Feb-94	Kerosene	Shell, Norco, LA
32	Spent caustic	R6-LT-01	09-Feb-94	Naph. Comb. Gas oil & Kero	Shell, Norco, LA
33	Crude oil tank sludge	R6B-CS-01	15-Mar-94	Mix of centrifuge and uncentrifuged	Shell, Norco, LA
34	Unleaded gasoline tank sludge	R6B-US-01	31-Mar-94	Water washed solids, collected by refinery	Shell, Norco, LA
35	Catalyst from polymerization	R6B-PC-01	15-Mar-94	Dimersol. filter	Shell, Norco, LA
36	Catalyst from hydrotreating	R7B-RC-01	14-Mar-94	Diesel hydrotreater	BP, Belle Chase, LA
37	Catalyst from reforming	R7B-CR-01	14-Mar-94	Platinum	BP, Belle Chase, LA
38	ASO	R5B-AS-01	16-Mar-94	Acid regen settler bottoms. not neutralized	Marathon, Garyville, LA



**Table 2.4. Descriptions of Samples Collected for Record Analysis (continued)**

Petroleum Refining Industry Study

18

August 1996

Count	Residual Name	Sample Number	Sample Date	Notes	Refinery
39	Catalyst from isomerization	R5B-1C-01	16-Mar-94	Butamer, platinum	Marathon, Garyville, LA
40	Off-spec sulfur	R7B-SP-01	14-Mar-94	From cleaned out tank	BP, Belle Chase, LA
41	Residual oil tank sludge	R8A-RS-01	30-Apr-94	CSO and Resid.	Amoco, Texas City
42	Unleaded gasoline tank sludge	R8A-US-01	14-Apr-94	Collected by refinery	Amoco, Texas City
43	Catalyst from hydrocracking	R8A-CC-01	30-Mar-94	Hydroproc., 1st stage cracker, CoMo	Amoco, Texas City
44	Catalyst from hydrotreating	R8A-TC-01	30-Mar-94	NiMo, landfilled	Amoco, Texas City
45	Off-spec product & fines from thermal processes	R8A-TP-01	30-Mar-94	Fines, F&K processed	Amoco, Texas City
46	H2SO4 alkylation sludge	R8B-SS-01	30-Apr-94	From Frog pond, not dewatered	Amoco, Texas City
47	HF alkylation sludge	R8B-HS-01	30-Apr-94	Not dewatered, dredged	Amoco, Texas City
48	Catalyst from isomerization	R8B-IC-01	30-Apr-94	Butamer, Pt	Amoco, Texas City
49	CSO sludge	R9-SO-01,02	17-May-94	Filters (and blank)	Murphy, Superior, WI
50	Desalting sludge	R9-DS-01	17-May-94		Murphy, Superior, WI
51	HF alkylation sludge	R9-HS-01	17-May-94		Murphy, Superior, WI
52	Catalyst from sulfur complex	R7B-SC-01	14-Mar-94	SCOT catalyst	BP, Belle Chase, LA
53	Crude oil tank sludge	R10-CS-01	26-Aug-94		Ashland, Catletsburg, KY
54	Catalyst from sulfur complex	R11-SC-01	10-May-94	SCOT, CoMo	ARCO, Ferndale, WA
55	Catalyst from hydrotreating	R11-TC-01	10-May-94	NiMo, naphtha treater	ARCO, Ferndale, WA
56	Catalyst from reforming	R11-CR-01	10-May-94	Pt/Rh	ARCO, Ferndale, WA
57	Treating clay	R11-CF-01	10-May-94	Reformer sulfur trap	ARCO, Ferndale, WA
58	Spent amine	R11-SA-01	10-May-94	DEA	ARCO, Ferndale, WA
59	Off-spec product & fines from thermal processes	R11-TP-01	10-May-94	Coke fines	ARCO, Ferndale, WA
60	Treating clay from lube oil	R13-CL-01	30-Apr-94	Clay dust	Shell, Deer Park, TX
61	Spent amine	R13-SA-01	30-Apr-94	DEA	Shell, Deer Park, TX
62	Spent caustic	R13-LT-01	30-Apr-94	Sulfidic	Shell, Deer Park, TX
63	Off-spec product & fines from thermal processes	R12-TP-01	12-May-94	Coke fines, from trap	Texaco, Anacortes, WA
64	Spent caustic	R12-LT-01	12-May-94	Cresylic	Texaco, Anacortes, WA
65	Unleaded gasoline tank sludge	R16-US-01	03-Aug-94		Koch
66	Catalyst from polymerization	R16-PC-01,02	03-Aug-94	2 catalysts from Dimersol and H2PO4	Koch
67	Crude oil tank sludge	R8C-CS-01	01-Jul-94	collected by refinery from tank bottom	Amoco, Texas City
68	Treating clay from extraction	R8D-CI-01	15-Nov-96	collected by refinery	Amoco, Texas City
69	Catalyst from hydrotreating	R18-TC-01	20-Oct-94	naphtha	Ashland, Canton, OH
70	Sulfur complex sludge	R18-ME-01	14-Oct-94	MEA sludge, collected by refinery	Ashland, Canton, OH
71	Catalyst from isomerization	R18-IC-01	20-Oct-94	Penex	Ashland, Canton, OH
72	CSO sludge	R1B-CS-01	26-Aug-94	mixed CSO/resid	Marathon, Indianapolis
73	Crude oil tank sludge	R4B-CS-01	26-Aug-94	Filter cake sludge	Little America
74	HF alkylation sludge	R15-HS-01	02-Aug-94	Dredged from pit	Total, Ardmore, OK
75	Catalyst from reforming	R15-CR-01	02-Aug-94	CCR fines	Total, Ardmore
76	Treating clay from alkylation	R15-CA-01	02-Aug-94	Butane	Total, Ardmore

**Table 2.4. Descriptions of Samples Collected for Record Analysis (continued)**

Count	Residual Name	Sample Number	Sample Date	Notes	Refinery
77	ASO	R15-AS-01	02-Aug-94	Neut., skimmed from pit	Total, Ardmore, OK
78	Spent amine	R15-SA-01	02-Aug-94	MDEA	Total, Ardmore, OK
79	Catalyst from reforming	R14-CR-01	07-Jun-94	Cyclic Pt reformer	BP, Toledo, OH
80	Sulfur complex sludge	R14-ME-01	07-Jun-94	DEA diatomaceous earth	BP, Toledo, OH
81	Off-spec product & fines from thermal processes	R14-TP-01	07-Jun-94	Delayed coking fines	BP, Toledo, OH
82	Spent amine	R14-SA-01	07-Jun-94	DEA from sump	BP, Toledo, OH
83	Catalyst from hydrotreating	R3B-TC-01	12-Jul-94	Naptha treater	Exxon, Billings, MT
84	Off-spec product & fines from thermal processes	R3B-TP-01	12-Jul-94	Fluid coker chunky coke	Exxon, Billings, MT
85	Catalyst from hydrotreating	R21-RC-01	31-Aug-94		Chevron, Port Arthur, TX
86	Treating clay from alkylation	R21-CA-01	31-Aug-94		Chevron, Port Arthur, TX
87	Catalyst from hydrocracking	R20-CC-01	30-Aug-94	H-Oil unit, moving bed	Star, Convent, LA
88	CSO sludge	R20-SO-01	30-Aug-94		Star, Convent, LA
89	Crude oil tank sludge	R19-CS-01	12-Oct-96		Pennzoil, Shreveport, LA
90	Desalting sludge	R11B-DS-01	01-Sep-94	collected by refinery	ARCO, Ferndale, WA
91	Crude oil tank sludge	R22-CS-01	21-Sep-94		Star, Port Arthur, TX
92	Residual oil tank sludge	R22-RS-01	21-Sep-94		Star, Port Arthur, TX
93	ASO	R7C-AS-01	12-Oct-96		BP, Belle Chase, LA
94	Catalyst from hydrotreating	R22-TC-01	21-Sep-94		Star, Port Arthur, TX
95	Spent caustic	R22B-LT-01	11-Oct-96	caustic from H2SO4 alky, sulfidic	Star, Port Arthur, TX
96	HF alkylation sludge	R7C-HS-01	12-Oct-96	Filter press	BP, Belle Chase, LA
97	Catalyst from isomerization	R23B-CI-01	19-Apr-95	Pt catalyst	Chevron, Salt Lake City
98	Treating clay from isomerization	R23B-IC-01	19-Apr-95	Mole sieve, butamer feed treater	Chevron, Salt Lake City
99	Treating clay from alkylation	R23-CA-01	19-Jan-95	propane treater	Chevron, Salt Lake City
100	Off-spec sulfur	R23-SP-01	19-Jan-95		Chevron, Salt Lake City
101	Treating clay from clay filtering	R23-CF-01	19-Jan-95	diesel washed	Chevron, Salt Lake City
102	Desalting sludge	R24-DS-01	20-Apr-95	Sludge from Lakos separator	Phibro, Houston, TX
<b>Familiarization Samples</b>					
F1	Spent Caustic	A-SC-01	08-May-93	Commingled.	Marathon, Garyville
F2	Catalyst from hydrotreating	A-HC-01	10-May-93	Cobalt molybdenum.	Marathon, Garyville
F3	Sulfur complex sludge	C-SS-01	23-Jun-93	MEA Reclaimer sludge.	Amoco, Texas City
F4	ASO	C-AS-01	23-Jun-93	Neutralized.	Amoco, Texas City
F5	Crude oil tank sludge	B-TS-01	15-May-93	Filter cake.	Sun, Philadelphia
F6	Sulfuric Acid Catalyst	B-SA-01	15-May-93	Spent from third unit.	Sun, Philadelphia

- Two samples of treating clay from isomerization/extraction were collected. This residual is available only for a brief period during unit turnarounds, which may occur only every 3-5 years. This residual was not readily available from the set of facilities selected for sampling.
- One sample of treating clay from lube oil processes was collected. Due to the specialty of the processes, a limited number of refineries produce lube oils and not all of these facilities use clay filtering. This residual is not readily available, and was extremely difficult to find from the facilities randomly selected for sampling.
- One sample of residual upgrading sludge was collected. This residual is not readily available from the set of facilities selected for sampling.
- No samples of off-specification product from residual upgrading were collected. As is discussed further in Section 3.7.2, the Agency believes that this residual was inappropriately classified as a residual due to the evaluation of inaccurate old data. This residual was reported as being generated by only one facility in the 1992 §3007 Survey.

Each of the samples collected was analyzed for the total and Toxicity Characteristics Leaching Procedure (TCLP) concentrations of the target analytes identified in the QAPjP. In addition, certain residuals were tested for different characteristics based on the Agency's understanding of the residuals developed during the engineering site visits. Each sample was also analyzed for the ten most abundant nontarget volatile and the 20 most abundant nontarget semi-volatile organics in each sample. These tentatively identified compounds (TICs) were not subjected to QA/QC evaluation (e.g., MS/MSD analyses) and thus were considered tentative.

### **2.2.6 Split Samples Analyzed by API**

The American Petroleum Institute (API) accompanied the EPA contractor (SAIC) on virtually all sampling trips and collected split samples of many of the record samples. API's analytical results for a number of the samples were made available to EPA for comparison purposes. In general, the Agency found that the API and EPA split sample analyses had very good agreement. Appendix B of the Listing Background Document, available in the RCRA docket for the 11/20/95 proposal, presents the Agency's comparison of the split sample results.

### **2.2.7 Synthesis**

The results of the Agency's four year investigation have been synthesized in this report and in the Listing Background document for the November 20, 1995 proposed rulemaking. Additional supporting documents are available in the docket for that rulemaking.

## 3.0 PROCESS AND WASTE DESCRIPTIONS

### 3.1 REFINERY PROCESS OVERVIEW

Refineries in the United States vary in size and complexity and are generally geared to a particular crude slate and, to a certain degree, reflect the demand for specific products in the general vicinity of the refinery. Figure 3.1 depicts a process flow diagram for a hypothetical refinery that employs the major, classic unit operations used in the refinery industry. These unit operations are described briefly below, and in more detail in the remainder of this section. Each subsection is devoted to a major unit operation that generates one or more of the study residuals of concern and provides information related to the process, a description of the residual and how and why it is generated, management practices used by the industry for each residual, the results of the Agency's characterization of each residual, and summary information regarding source reduction opportunities and achievements.

**Storage Facilities:** Large storage capacities are needed for refinery feed and products. Sediments from corrosion and impurities accumulate in these storage tanks. The consent decree identifies sludges from the storage of crude oil, clarified slurry oil, and unleaded gasoline for consideration as listed wastes. Residual oil storage tank sludge was identified as a study residual.

**Crude Desalting:** Clay, salt, and other suspended solids must be removed from the crude prior to distillation to prevent corrosion and deposits. These materials are removed by water washing and electrostatic separation. Desalting sludge is a study residual.

**Distillation:** After being desalted, the crude is subjected to atmospheric distillation, separating the crude by boiling point into light ends, naphtha, middle distillate (light and heavy gas oil), and a bottoms fraction. The bottoms fraction is frequently subjected to further distillation under vacuum to increase gas oil yield. No residuals from distillation are under investigation.

**Catalytic Cracking:** Catalytic cracking converts heavy distillate to compounds with lower boiling points (e.g., naphthas), which are fractionated. Cracking is typically conducted in a fluidized bed reactor with a regenerator to continuously reactivate the catalyst. Cracking catalysts are typically zeolites. The flue gas from the regenerator typically passes through dry or wet fines removal equipment and carbon monoxide oxidation prior to being released to the atmosphere. Catalyst and fines, as well as sediments from storage of and solids removal from clarified slurry oil (the bottoms fraction from catalytic cracking), are listing residuals of concern.

**Hydroprocessing:** Hydroprocessing includes (1) **hydrotreating and hydrorefining (or hydrodesulfurization)**, which improve the quality of various products (e.g., by removing sulfur, nitrogen, oxygen, metals, and waxes and by converting olefins to saturated compounds); and (2) **hydrocracking**, which cracks heavy materials, creating lower-boiling, more valuable products. Hydrotreating is typically less severe than hydrorefining and is applied to lighter cuts. Hydrocracking is a more severe operation than hydrorefining, using higher temperature and longer contact time, resulting in significant reduction in feed molecular size. Hydroprocessing catalysts

Figure 3.1. Simplified Refinery Process Flow Diagram

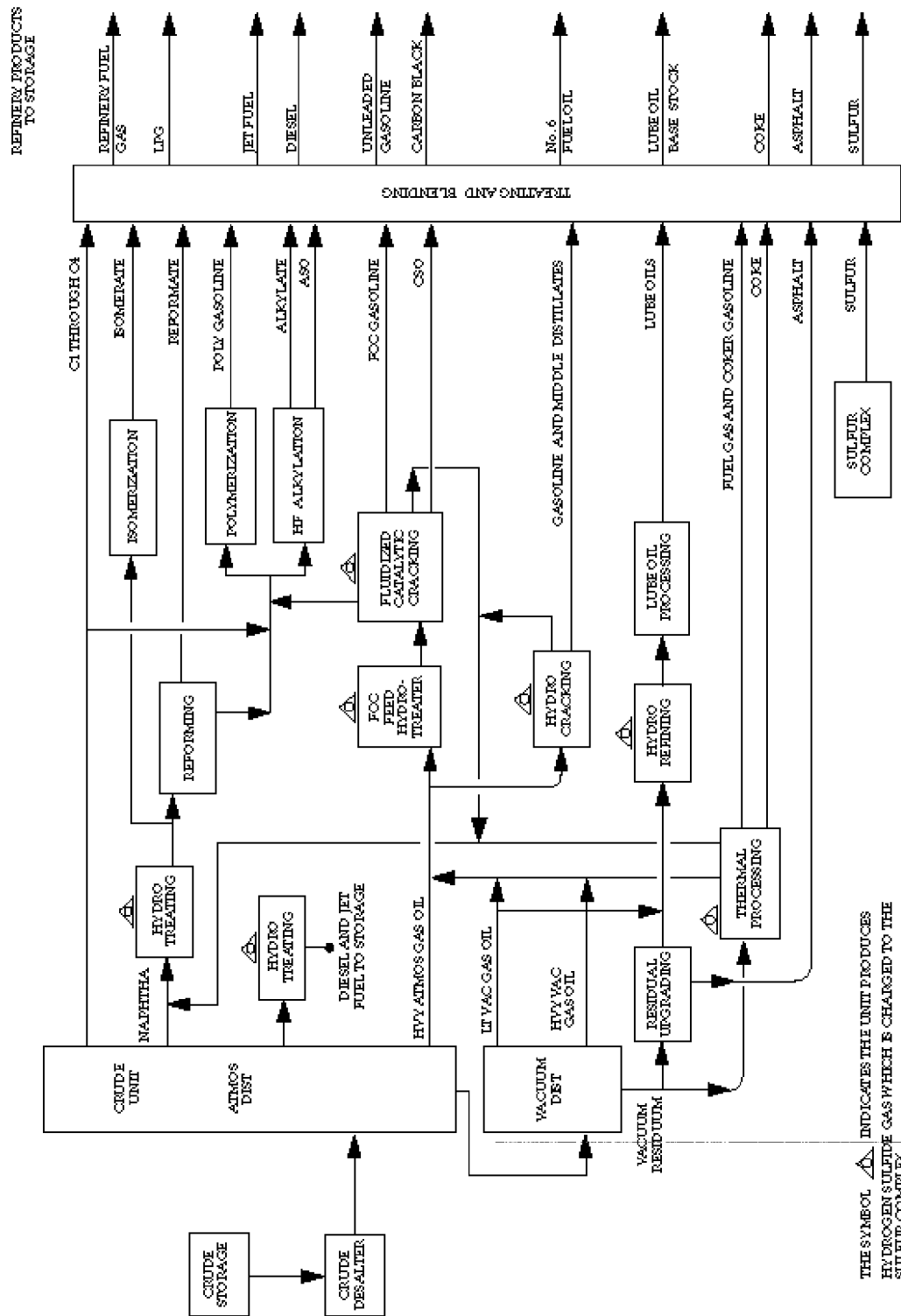

THE SYMBOL  $\Delta$  INDICATES THE UNIT PRODUCES HYDROGEN SULFIDE GAS WHICH IS CHARGED TO THE SULFUR COMPLEX.

are typically some combination of nickel, molybdenum, and cobalt. Typical applications of hydroprocessing include treating distillate to produce low-sulfur diesel fuel, treating naphtha reformer feed to remove catalyst poisons, and treating catalytic cracking unit feed to reduce catalyst deactivation. Hydrotreating and hydrorefining catalysts are listing residuals, while hydrocracking catalyst is a study residual.

**Thermal Processes:** Thermal cracking uses the application of heat to reduce high-boiling compounds to lower-boiling products. **Delayed (batch) or fluid (continuous) coking** is essentially high-severity thermal cracking and is used on very heavy residuum (e.g., vacuum bottoms) to obtain lower-boiling cracked products. (Residuum feeds are not amenable to catalytic processes because of fouling and deactivation.) Products are olefinic and include gas, naphtha, gas oils, and coke. **Visbreaking** is also thermal cracking; its purpose is to decrease the viscosity of heavy fuel oil so that it can be atomized and burned at lower temperatures than would otherwise be necessary. **Other processes** conducting thermal cracking also would be designated as thermal processes. Off-spec product and fines is a listing residual from these processes.

**Catalytic Reforming:** Straight run naphtha is upgraded via reforming to improve octane for use as motor gasoline. Reforming reactions consist of (1) dehydrogenation of cycloparaffins to form aromatics and (2) cyclization and dehydrogenation of straight chain aliphatics to form aromatics. Feeds are hydrotreated to prevent catalyst poisoning. Operations may be semiregenerative (cyclic), fully-regenerative, or continuous (moving bed) catalyst systems. Precious metal catalysts are used in this process. Spent reforming catalyst is a listing residual.

**Polymerization:** Polymerization units convert olefins (e.g., propylene) into higher octane polymers. Two principal types of polymerization units include fixed-bed reactors, which typically use solid-supported phosphoric acid as the catalyst, and Dimersol® units, which typically use liquid organometallic compounds as the catalyst. Spent polymerization catalyst is a study residual.

**Alkylation:** Olefins of 3 to 5 carbon atoms (e.g., from catalytic cracking and coking) react with isobutane (e.g., from catalytic cracking) to give high octane products. Sulfuric ( $H_2SO_4$ ) or hydrofluoric (HF) acid act as catalysts. Spent sulfuric acid, sulfuric acid alkylation sludges, and HF sludges are listing residuals, while spent HF acid, acid soluble oil and treating clays are study residuals.

**Isomerization:** Isomerization converts straight chain paraffins in gasoline stocks into higher octane isomers. Isomer and normal paraffins are separated; normal paraffins are then catalytically isomerized. Precious metal catalysts are used in this process. Spent catalysts and treating clays are study residuals from this process.

**Extraction:** Extraction is a separation process using differences in solubility to separate, or extract, a specific group of compounds. A common application of extraction is the separation of benzene from reformate. Treating clay is a study residual from this process.

**Lube Oil Processing:** Vacuum distillates are treated and refined to produce a variety of lubricants. Wax, aromatics, and asphalts are removed by unit operations such as solvent extrac-

tion and hydroprocessing; clay may also be used. Various additives are used to meet product specifications for thermal stability, oxidation resistances, viscosity, pour point, etc. Treating clay is a study residual from this process.

**Residual Upgrading:** Vacuum tower distillation bottoms and other residuum feeds can be upgraded to higher value products such as higher grade asphalt or feed to catalytic cracking processes. Residual upgrading includes processes where asphalt components are separated from gas oil components by the use of a solvent. It also includes processes where the asphalt value of the residuum is upgraded (e.g., by oxidation) prior to sale. Off-spec product and fines, as well as process sludges, are study residuals from this category.

**Blending and Treating:** Various petroleum components and additives are blended to different product (e.g., gasoline) specifications. Clay and caustic may be used to remove sulfur, improve color, and improve other product qualities. Spent caustic is a listing residual, while treating clay is a study residual.

**Sulfur Recovery:** Some types of crude typically contain high levels of sulfur, which must be removed at various points of the refining process. Sulfur compounds are converted to  $H_2S$  and are removed by amine scrubbing. The  $H_2S$  often is converted to pure sulfur in a Claus plant. Off-gases from the Claus plant typically are subject to tail gas treating in a unit such as a SCOT® treater for additional sulfur recovery. Process sludges and spent catalysts are listing residuals; off-spec product and off-spec treating solutions are study residuals.

**Light Ends (Vapor) Recovery:** Valuable light ends from various processes are recovered and separated. Fractionation can produce light olefins and isobutane for alkylation, n-butane for gasoline, and propane for liquid petroleum gas (LPG). Caustic may be used to remove sulfur compounds. Spent caustic is a listing residual of concern.

## 3.2 CRUDE OIL DESALTING

Crude oil removed from the ground is contaminated with a variety of substances, including gases, water, and various minerals (dirt). Cleanup of the crude oil is achieved in two ways. First, field separation, located near the site of the oil wells, provides for gravity separation of the three phases: gases, water (with entrained dirt), and crude oil. The second cleanup operation is crude oil desalting conducted at the refinery. Crude oil desalting is a water-washing operation prior to atmospheric distillation which achieves additional crude oil cleanup. Water washing removes much of the water-soluble minerals and suspended solids from the crude. If these contaminants were not removed, they would cause a variety of operating problems throughout the refinery including the blockage of equipment, the corrosion of equipment, and the deactivation of catalysts.

### 3.2.1 Process Description

To operate efficiently and effectively the crude oil desalter must achieve an intimate mixing of the water wash and crude, and then separate the phases so that water will not enter downstream unit operations. The crude oil entering a desalting unit is typically heated to 100 - 300°F to achieve reduced viscosity for better mixing. In addition, the desalter operates at pressures of at least 40 lb/in<sup>2</sup> gauge to reduce vaporization. Intimate mixing is achieved through a throttling valve or emulsifier orifice and the oil-water emulsion is then introduced into a gravity settler. The settler utilizes a high-voltage electrostatic field to agglomerate water droplets for easier separation. Following separation, the water phase is discharged from the unit, carrying salt, minerals, dirt, and other water-soluble materials with it.

Desalting efficiency can be increased by the addition of multiple stages, and in some cases acids, caustic, or other chemicals may be added to promote additional treatment. A simplified process flow diagram for crude oil desalting is shown in Figure 3.2.1.

**Figure 3.2.1. Desalting Process Flow Diagram**

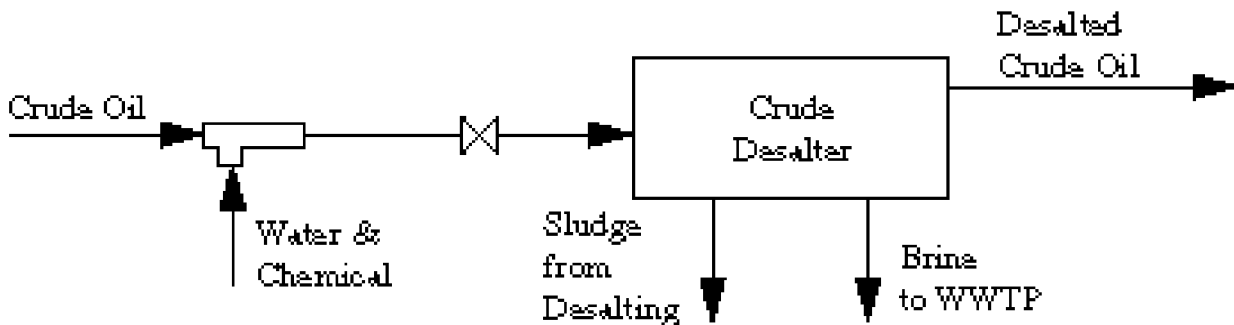



## 3.2.2 Desalting Sludge

### 3.2.2.1 Description

Desalting sludge is continuously separated from the crude oil and settles to the bottom of the desalter with the water wash. The majority of the sludge is removed from the desalter with the water wash and is discharged to the facility's wastewater treatment plant. The sludge then becomes part of the wastewater treatment sludges. On a regular basis (e.g., weekly), water jets at the bottom of the desalter are activated, stirring up sludge that has built up on the bottom of the unit and flushing it to wastewater treatment. This process is known as “mud washing” and allows the units to continue to operate without shutting down for manual sludge removal.

Desalting sludge is removed from the unit during unit turnarounds, often associated with turnarounds of the distillation column. These turnarounds are infrequent (e.g., every several years). Some refineries operate enough desalters in parallel to allow for turnarounds while the distillation columns continue to operate.

At turnaround, the sludge can be removed in several different ways. Based on the results of the questionnaire, approximately half of the total number of desalting sludge waste streams are removed from the desalter using a vacuum truck, permanent or portable piping, or other similar means where the sludge is removed in a slurry state. Another 25 percent of the sludges are removed manually by maintenance workers while the removal method for the remaining 25 percent of the sludges was not clear. The questionnaire data further indicated that half of the desalting sludge streams are further piped or stored in tanker trucks following removal, while the remaining half are stored in drums or a dumpster.

As with some tank sludges, some facilities remove their desalting sludge using a vacuum truck or similar slurring device, then centrifuge the material and store the solids in a drum or dumpster. Such procedures would explain the apparent discrepancy between the number of streams removed as solid and the number of streams stored in containers (presumably also as solid). Questionnaire data indicate that approximately 10 percent of the streams generated in 1992 underwent dewatering or a similar volume reduction procedure.

### 3.2.2.2 Generation and Management

Eighty facilities reported generating a total quantity of 4,841 MT of desalting sludge in 1992, according to the 1992 RCRA §3007 Survey. Desalting sludge includes material generated from turnaround operations; materials continuously flushed to wastewater treatment are generally omitted. The survey contained a residual identification code for “desalter sludge”. All residuals assigned this code, and any misidentified residual determined to be desalter sludge generated from a process assigned process code for “desalting” were considered “desalter sludge” residuals. This corresponds to residual code 02-A in Section VII.2 of the survey and process code 01-A, 01-B, 01-C, and 01-D in Section IV-1.C. Quality assurance was conducted to ensure that all desalting sludge residuals were correctly identified and coded.

Based on the results of the survey, 148 facilities use desalting units and are thus likely to generate desalting sludge. Due to the infrequent generation of this residual, not all of these 148 facilities generated desalting sludge in 1992. In addition, some facilities do not generate desalting sludge at all because they do not conduct unit turnarounds, or do not find any settled sludge when conducting maintenance. However, there was no reason to expect that 1992 would not be a typical year with regard to desalting sludge generation and management. Table 3.2.1 provides a description of the quantity generated, number of streams reported, number of streams not reporting volumes (data requested was unavailable and facilities were not required to generate it), total and average volumes.

**Table 3.2.1. Generation Statistics for Desalting Sludge, 1992**

Final Management	# of Streams	# of Streams w/ Unreported Volume	Total Volume (MT)	Average Volume (MT)
Discharge to onsite wastewater treatment facility	25	9	2,041.62	81.66
Disposal in onsite or offsite underground injection	1	0	2.00	2.00
Disposal in offsite Subtitle D landfill	14	1	28.80	2.06
Disposal in offsite Subtitle C landfill	15	5	221.40	14.76
Disposal in onsite Subtitle D landfill	2	0	102.00	51.00
Offsite incineration	8	1	56.00	7.00
Offsite land treatment	4	0	53.20	13.30
Onsite land treatment	8	0	345.76	43.22
Recovery onsite in a coker	3	3	52.40	17.47
Transfer for direct use as a fuel or to make a fuel	17	1	1,937.60	113.98
<b>TOTAL</b>	<b>97</b>	<b>20</b>	<b>4,840.78</b>	<b>49.90</b>

Note that 42 percent of desalting sludge volumes are discharged to onsite wastewater treatment. During engineering site and sampling visits, it was observed that refineries would simply flush the sludge to wastewater treatment during desalter turnarounds in a manner similar to mud washing.

Over half of the desalting sludge residuals (48) were reported to be managed as characteristically hazardous (most commonly D018), accounting for 40 percent of the sludge volume.<sup>4</sup> Twenty seven of these streams were managed with F or K listed wastes, reflecting their frequent management in wastewater treatment systems.

---

<sup>4</sup>These percentages do not match up directly with any one of the management scenarios because the number of streams and the volume are a combination of several management scenarios (i.e., managed in WWTP, Subtitle C landfill, transfer as a fuel, etc.).

### 3.2.2.3 Plausible Management

EPA believes that most of the plausible management practices for this residual were reported in the 1992 RCRA §3007 Survey, as summarized above in Table 3.2.1. The Agency gathered information suggesting other management practices had been used in other years including: “disposal in onsite Subtitle C landfill” (86 MT), “disposal in onsite surface impoundment” (1 MT), and “recovery onsite via distillation” (0.5 MT). These non-1992 practices are generally comparable to practices reported in 1992 (i.e., off-site Subtitle C landfilling and recovery in a coker). The very small volume reported to have been disposed in a surface impoundment reflects the management of this residual with the refinery’s wastewater in a zero discharge wastewater treatment facility with a final evaporation pond; this management practice is comparable to the 1992 reported practice of “disposal in onsite wastewater treatment facility”. EPA also compared management practices reported for desalting sludge to those reported for crude oil tank sediment because of expected similarities in composition and management. Similar land disposal practices were reported for both residuals.

### 3.2.2.4 Characterization

Two sources of residual characterization data were developed during the industry study:

- Table 3.2.2 summarizes the physical properties of desalting sludge as reported in Section VII.A of the RCRA §3007 survey.
- Four record samples of desalting sludge were collected and analyzed by EPA. These sludges represent the various types of desalting operations and sludge generation methods typically used by the industry and are summarized in Table 3.2.3. The samples represent sludges generated during turnaround operations (the most common way desalting sludge is generated), and also represents sludges both with and without undergoing interim deoiling or dewatering steps.

Table 3.2.4 provides a summary of the characterization data collected under this sampling effort. The record samples are believed to be representative of desalting sludge as typically generated by the industry. All four record samples were analyzed for total and TCLP levels of volatiles, semivolatiles, and metals. Two of three samples analyzed for TCLP Benzene exhibited the toxicity characteristic for benzene (i.e., the level of benzene in these samples' TCLP extracts exceeded the corresponding regulatory level). Only constituents detected in at least one sample are shown in Table 3.2.4.

### 3.2.2.5 Source Reduction

The electrostatic desalter removes most of the solids, salts and water present in the crude oil. Minimizing the introduction or recycling of solids to the crude unit will assist the reduction of desalting sludge, since solids attract oil and produce emulsions.

The amount of desalting sludge formed is a function of the efficiency of the desalter but more fundamentally is a characteristic of the crude oil. Methods of managing desalting sludge center on increasing the efficiency of the desalter and de-emulsifiers which increase the capability of separating the oil, water and solid phases.

Reference	Waste Minimization/Management Methods
"New Process Effectively Recovers Oil From Refinery Waste Streams." <i>Oil &amp; Gas Journal</i> . August 15, 1994.	Enhanced separation of oil, water and solids.
"Filtration Method Efficiently Desalts Crude in Commercial Test." <i>Oil &amp; Gas Journal</i> . May 17, 1993.	Alternative process: single-stage filtration.
D.T. Cindric, B. Klein, A.R. Gentry and H.M. Goma. "Reduce Crude Unit Pollution With These Technologies." <i>Hydrocarbon Processing</i> . August, 1993.	Includes topic of more effective separation of phases in desalter.
"Waste Minimization in the Petroleum Industry: A Compendium of Practices." API. November, 1991.	Practices described: 1. Shear mixing used to mix desalter wash water and crude. 2. Turbulence avoided by using lower pressure water to prevent emulsion formation.

**Table 3.2.2. Desalter Sludge: Physical Properties**

Properties	# of Values	# of Unreported Values <sup>1</sup>	10th %	50th %	90th %
pH	118	144	6.10	7.00	8.40
Reactive CN, ppm	60	202	0.15	1.00	250.00
Reactive S, ppm	67	195	0.80	82.00	500.00
Flash Point, °C	73	189	43.89	60.00	94.44
Oil and Grease, vol%	103	159	5.00	16.00	70.00
Total Organic Carbon, vol%	47	215	1.00	15.00	35.00
Vapor Pressure, mm Hg	14	248	0.00	10.50	150.00
Vapor Pressure Temperature, °C	9	253	20.00	30.00	40.00
Viscosity, lb/ft-sec	3	259	0.00	0.00	1500.00
Viscosity Temperature, °C	5	257	0.00	30.00	50.00
Specific Gravity	69	193	0.90	1.10	1.70
BTU Content, BTU/lb	56	206	270.00	3,590.00	10,000.00
Aqueous Liquid, %	157	105	0.00	30.00	78.00
Organic Liquid, %	151	111	0.00	15.00	50.00
Solid, %	170	92	9.00	45.00	100.00
Other, %	111	151	0.00	0.00	30.00
Particle >60 mm, %	10	252	0.00	0.00	50.00
Particle 1-60 mm, %	9	253	0.00	90.00	100.00
Particle 100 µm-1 mm, %	12	250	0.00	10.00	100.00
Particle 10-100 µm, %	9	253	0.00	0.00	100.00
Particle <10 µm, %	8	254	0.00	0.00	0.00
Median Particle Diameter, microns	7	255	0.00	200.00	2,000.00

<sup>1</sup>Facilities were not required to do additional testing, therefore information provided was based on previously collected data or engineering judgment.

**Table 3.2.3. Desalting Sludge Record Sampling Locations**

Sample No.	Facility	Description
R1-DS-01	Marathon, Indianapolis, IN	From electrostatic precipitator turnaround. Sludge/slurry removed directly from unit
R9-DS-01	Murphy, Superior, WI	Turnaround sludge/slurry taken from drums
R11-DS-01	ARCO, Ferndale, WA	Dewatered sludge from turnaround taken from bins
R24-DS-01	Phibro, Houston, TX	Continuously generated "solids" from brine separator; sample mostly aqueous

**Table 3.2.4. Desalting Sludge Characterization**

Petroleum Refining Industry Study

31

August 1996

Volatile Organics - Method 8260A µg/kg					( µg/L )				
	CAS No.	R1-DS-01	R9-DS-01	R11B-DS-01	R24-DS-01	Average Conc	Maximum Conc	Comments	
Acetone	67641	200,000	< 625	< 1,250	160	67,292	200,000		
Benzene	71432	230,000	22,000	28,000	36	93,333	230,000		
n-Butylbenzene	104518	< 62,500	42,000	31,000	< 5	36,500	42,000	1	
sec-Butylbenzene	135988	< 62,500	24,000	19,000	< 5	21,500	24,000	1	
Ethylbenzene	100414	180,000	150,000	48,000	J 7	126,000	180,000		
Isopropylbenzene	98828	< 62,500	36,000	27,000	< 5	31,500	36,000	1	
p-Isopropyltoluene	99876	< 62,500	25,000	18,000	< 5	21,500	25,000	1	
Methylene chloride	75092	J 49,000	< 625	< 1,250	< 5	16,958	49,000		
Methyl ethyl ketone	78933	< 62,500	< 625	< 1,250	41	NA	NA		
n-Propylbenzene	103651	< 62,500	74,000	44,000	< 5	60,167	74,000		
Toluene	108883	660,000	220,000	61,000	77	313,667	660,000		
1,2,4-Trimethylbenzene	95636	350,000	230,000	68,000	35	216,000	350,000		
1,3,5-Trimethylbenzene	108678	140,000	85,000	34,000	12	86,333	140,000		
o-Xylene	95476	290,000	190,000	54,000	38	178,000	290,000		
m,p-Xylenes	108383 / 106423	950,000	380,000	67,000	70	465,667	950,000		
Naphthalene	91203	< 62,500	55,000	54,000	32	54,500	55,000	1	
TCLP Volatile Organics - Methods 1311 and 8260A µg/L									
	CAS No.	R1-DS-01	R9-DS-01	R11B-DS-01	R24-DS-01	Average Conc	Maximum Conc	Comments	
Acetone	67641	770	< 50	B 260	NA	360	770		
Benzene	71432	5,200	1,700	280	NA	2,393	5,200		
Ethylbenzene	100414	550	340	120	NA	337	550		
Toluene	108883	5,200	2,000	760	NA	2,653	5,200		
1,2,4-Trimethylbenzene	95636	< 250	190	J 69	NA	130	190	1	
1,3,5-Trimethylbenzene	108678	< 250	J 54	J 22	NA	38	54	1	
Methylene chloride	75092	1,000	1,200	J 23	NA	741	1,200		
o-Xylene	95476	1,100	540	200	NA	613	1,100		
m,p-Xylene	108383 / 106423	2,400	1,100	490	NA	1,330	2,400		
Naphthalene	91203	< 250	< 50	JB 52	NA	51	52	1	
Semivolatile Organics - Method 8270B µg/kg					( µg/L )				
	CAS No.	R1-DS-01	R9-DS-01	R11B-DS-01	R24-DS-01	Average Conc	Maximum Conc	Comments	
Benzo(a)pyrene	50328	J 4,300	J 5,600	< 10,000	< 5	4,950	5,600	1	
Carbazole	86748	< 13,200	< 20,625	< 20,000	43	NA	NA		
Chrysene	218019	< 6,600	< 10,313	J 13,000	< 5	9,971	13,000		
Dibenzofuran	132649	< 6,600	12,000	J 16,000	< 5	11,533	16,000		
2,4-Dimethylphenol	105679	< 6,600	< 10,313	< 10,000	190	NA	NA		
Fluorene	86737	J 6,000	24,000	26,000	< 5	18,667	26,000		

Table 3.2.4. Desalting Sludge Characterization (continued)

Semivolatile Organics - Method 8270B µg/kg (continued)					(µg/L)				
	CAS No.	R1-DS-01	R9-DS-01	R11B-DS-01	R24-DS-01	Average Conc	Maximum Conc	Comments	
Phenanthrene	85018	J 12,000	61,000	68,000	26	47,000	68,000		
Phenol	108952	< 6,600	< 10,313	< 10,000	900	NA	NA		
Pyrene	129000	< 6,600	J 10,000	< 10,000	< 5	8,867	10,000		
1-Methylnaphthalene	90120	48,000	220,000	180,000	81	149,333	220,000		
2-Methylnaphthalene	91576	66,000	330,000	240,000	130	212,000	330,000		
2-Methylchrysene	3351324	< 13,200	J 13,000	< 20,000	< 10	13,000	13,000	1	
2-Methylphenol	95487	< 6,600	< 10,313	< 10,000	340	NA	NA		
3/4-Methylphenol	NA	< 6,600	< 10,313	< 10,000	530	NA	NA		
Naphthalene	91203	33,000	110,000	130,000	110	91,000	130,000		
TCLP Semivolatile Organics - Methods 1311 and 8270B µg/L									
	CAS No.	R1-DS-01	R9-DS-01	R11B-DS-01	R24-DS-01	Average Conc	Maximum Conc	Comments	
Benzo(a)pyrene	50328	JB 16	< 50	< 50	NA	16	16	1	
Bis(2-ethylhexyl)phthalate	117817	< 50	B 500	< 50	NA	200	500		
Di-n-butyl phthalate	84742	< 50	< 50	J 20	NA	20	20	1	
2,4-Dimethylphenol	105679	J 26	< 50	J 73	NA	50	73		
1-Methylnaphthalene	90120	J 32	J 50	J 71	NA	51	71		
2-Methylnaphthalene	91576	J 34	J 60	J 92	NA	62	92		
2-Methylphenol	95487	J 48	J 25	J 43	NA	39	48		
3/4-Methylphenol	NA	J 68	J 40	J 49	NA	52	68		
Naphthalene	91203	J 86	J 61	120	NA	89	120		
Phenol	108952	200	< 50	J 54	NA	101	200		
Total Metals - Methods 6010, 7060, 7421, 7470, 7471, and 7841 mg/kg					(mg/L)				
	CAS No.	R1-DS-01	R9-DS-01	R11B-DS-01	R24-DS-01	Average Conc	Maximum Conc	Comments	
Aluminum	7429905	2,600	3,700	7,500	11.0	4,600	7,500		
Antimony	7440360	16.0	14.0	< 6.00	0.28	12.0	16.0		
Arsenic	7440382	16.0	34.0	16.0	0.05	22.0	34.0		
Barium	7440393	2,200	1,700	1,400	1.80	1,767	2,200		
Beryllium	7440417	< 0.50	< 0.50	1.40	< 0.0025	0.80	1.40		
Cadmium	7440439	2.90	1.80	3.40	< 0.0025	2.70	3.40		
Calcium	7440702	16,000	5,300	3,300	230	8,200	16,000		
Chromium	7440473	110	76.0	150	0.17	112	150		
Cobalt	7440484	27.0	16.0	13.0	< 0.025	18.7	27.0		
Copper	7440508	680	340	430	1.20	483	680		
Iron	7439896	71,000	55,000	77,000	200	67,667	77,000		

**Table 3.2.4. Desalting Sludge Characterization (continued)**

Total Metals - Methods 6010, 7060, 7421, 7470, 7471, and 7841 mg/kg (continued)					(mg/L)		Average Conc	Maximum Conc	Comments
	CAS No.	R1-DS-01	R9-DS-01	R11B-DS-01	R24-DS-01				
Lead	7439921	1,100	390	160	0.36	550	1,100		
Magnesium	7439954	2,200	3,200	3,300	68.0	2,900	3,300		
Manganese	7439965	310	250	450	1.60	337	450		
Mercury	7439976	41.0	4.40	39.0	0.0085	28.1	41.0		
Molybdenum	7439987	17.0	19.0	16.0	< 0.034	17.3	19.0		
Nickel	7440020	76.0	100	110	0.48	95.3	110		
Potassium	7440097	< 500	< 500	< 500	41.0	NA	NA		
Selenium	7782492	140	22.0	75.0	< 0.0025	79.0	140		
Sodium	7440235	< 500	< 500	< 500	830	NA	NA		
Thallium	7440280	< 1.00	7.00	< 1.00	< 0.005	3.00	7.00		
Vanadium	7440622	36.0	37.0	120	0.12	64.3	120		
Zinc	7440666	1,300	1,900	5,400	2.20	2,867	5,400		
TCLP Metals - Methods 1311, 6010, 7060, 7421, 7470, 7471, and 7841 mg/L									
	CAS No.	R1-DS-01	R9-DS-01	R11B-DS-01	R24-DS-01	Average Conc	Maximum Conc	Comments	
Aluminum	7429905	7.60	< 1.00	< 1.00	NA	3.20	7.60		
Barium	7440393	2.60	< 1.00	3.50	NA	2.37	3.50		
Calcium	7440702	580	150.00	54.0	NA	261	580		
Chromium	7440473	0.87	< 0.05	0.12	NA	0.35	0.87		
Iron	7439896	210	24.00	190	NA	141	210		
Magnesium	7439954	71.0	< 25.0	< 25.0	NA	40.3	71.0		
Manganese	7439965	6.00	1.60	4.60	NA	4.07	6.00		
Nickel	7440020	< 0.20	< 0.20	0.52	NA	0.31	0.52		
Zinc	7440666	2.00	2.90	57.00	NA	20.6	57.0		

Comments:

- 1 Detection limits greater than the highest detected concentration are excluded from the calculations.

Notes:

- B Analyte also detected in the associated method blank.
- J Compound's concentration is estimated. Mass spectral data indicate the presence of a compound that meets the identification criteria for which the result is less than the laboratory detection limit, but greater than zero.
- NA Not Applicable.



### 3.3 HYDROCRACKING

Petroleum refining hydroprocessing techniques include hydrocracking, hydrorefining, and hydrotreating. Hydrorefining and hydrotreating processes and their respective catalyst residuals are described in the Listing Background Document for the November 20, 1995 proposed rule. Hydrocracking processes are similar to hydrotreating and hydrorefining processes in that they remove organic sulfur and nitrogen from the process feeds, but differ in that they also serve to break heavier fraction feeds into lighter fractions. As refinery crudes have become heavier, hydrocracking, a more recent process development compared to long-established conversion processes such as thermal cracking, has become more widely used. The current trend to heavier feeds and lighter high-quality feeds causes hydrocracking to offer advantages to future refining operations.

In addition, hydrocracking is a versatile process, and under mild conditions can be utilized for hydrotreating (typically fractions that need to be saturated to give good burning quality) and under more severe conditions can be utilized as a cracker (typically feeds that are too heavy or too contaminant-laden for catalytic cracking). As a result of this flexibility, hydrocracking processes can appear in refinery operations in a number of different places.

#### 3.3.1 Process Description

The process flow for hydrocracking is similar to that for hydrotreating: the feed is mixed with a hydrogen-rich gas, pumped to operating pressure and heated, and fed to one or more catalytic reactors in series. Hydrocracking units are typically designed with two stages: the first uses a hydrotreating catalyst to remove nitrogen and heavy aromatics, while the second stage conducts cracking. The catalysts for each stage are held in separate vessels. Organic sulfur and nitrogen are converted to  $H_2S$  and  $NH_3$ , and some unsaturated olefins or aromatics are saturated or cracked to form lighter compounds. In addition, heavy metal contaminants are adsorbed onto the catalyst. Following the reactor, the effluent is separated via stabilization and fractionation steps into its various fractions. There are two major differences between hydrocracking and hydrotreating: 1) operating pressures are much higher, in the range from 2,000 - 3,000 lb/in<sup>2</sup> gauge, and 2) hydrogen consumption is much higher, in the range from (1,200 - 1,600 SCF/barrel of feed), dependent on the feed. The feed is generally a heavy gas oil or heavier stream.

Catalysts employed in hydrocracking reactors have multiple functions. First, the catalyst has a metallic component (cobalt, nickel, tungsten, vanadium, molybdenum, platinum, palladium, or a combination of these metals) responsible for the catalysis of the hydrogenation and desulfurization/denitration reactions. In addition, these metals are supported on a highly acidic support (silica-alumina, acid-treated clays, acid-metal phosphates, or alumina) responsible for the cracking reactions. A simplified process flow diagram is shown in Figure 3.3.1.

**Figure 3.3.1. Hydrocracking Process Flow Diagram**

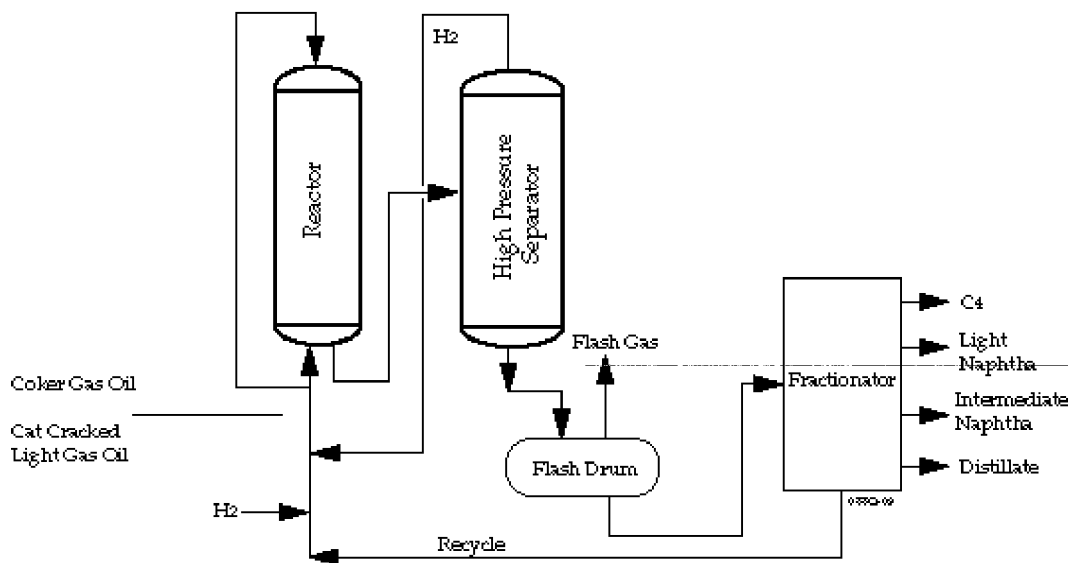

### 3.3.2 Spent Hydrocracking Catalyst

#### 3.3.2.1 Description

Metal deposition acts to deactivate, or poison, the hydrocracking catalyst. In addition, carbon from the cracking reactions deactivates the catalyst. The catalyst's life is dependent on the severity of cracking and metal deposition and is changed out every 6 months to 8 years. The catalyst closest to the entrance (top) of the reactor becomes deactivated first, and for this reason is sometimes replaced more frequently than the entire reactor contents (a "topping" operation). When catalyst activity is unacceptable, the reactor is taken out of service and typically undergoes a hydrogen sweep to burn residual hydrocarbon, then a nitrogen sweep to cool the reactor and remove occupational hazards such as hydrogen sulfide and benzene. Such procedures were reported by most facilities. The following additional procedures were reported to be employed by fewer facilities, typically only one or two:

- Oxidation (to burn residual hydrocarbon)
- Cat nap technology or diesel wash (to lower vapor pressure of hazardous volatiles)
- Wet dump, water wash, or soda ash wash (to neutralize sulfides and remove volatiles)
- Steam stripping (to remove volatiles)
- Evacuation (a technique possibly similar to nitrogen sweep)
- Some facilities report using no pretreatment methods prior to catalyst removal.

In some processes, a moving bed of catalyst is used instead of a fixed bed. In this process, catalyst is continuously and slowly moved countercurrent to the hydrocarbon flow. Spent catalyst is generated almost continuously and fresh catalyst added as needed for makeup. This configuration differs significantly from the fixed bed design with respect to spent catalyst generation frequency.

Unlike hydrotreating and hydrorefining catalysts (discussed in *Listing Background Document*), both precious metal and nonprecious metal catalysts are used in hydrocracking processes. Based on a total of 46 facilities reporting spent hydrocracking catalyst generation, 34 (74%) reported using nickel/molybdenum, 11 (24%) reported using nickel/tungsten, and 11 (24%) reported using palladium. An additional 16 facilities (35%) reported using other metals in their catalyst such as cobalt, copper, magnesium, monometallic nickel, phosphorus, tin, and zinc. As stated in Section 3.3.1, many hydrocracking units are constructed as a hydrorefining stage followed by a cracking stage. In reporting catalysis use, refineries may not have differentiated between hydrorefining and cracking functions in their response. In this section, data for both pretreatment (hydrorefining function) and hydrocracking catalysts are presented.

Approximately 2,500 MT of the hydrocracking catalyst generated in 1992 was identified as displaying hazardous characteristics.<sup>5</sup> This is approximately 15 percent of the total volume managed. The most commonly displayed hazardous waste codes were D001 (ignitable), D003 (reactive), D004 (TC arsenic) and D018 (TC benzene).

### 3.3.2.2 Generation and Management

During reactor change-outs, spent hydrocracking catalysts are removed from the reactors using a variety of techniques including gravity dumping and water drilling. Upon removal from the catalyst bed, the catalyst may be screened to remove fines or catalyst support media. The catalyst is typically stored in covered bins pending shipment off site for disposal or recovery.

Twenty-eight facilities reported generating a total quantity of 18,000 MT of this residual in 1992, according to the 1992 RCRA §3007 Questionnaire. Residuals were assigned to be “spent hydrocracking catalyst” if they were assigned a residual identification code of “spent solid catalyst” or “spent catalyst fines” and were generated from a process identified as a hydrocracking unit. These correspond to residual code 03-A in Section VII.2 of the questionnaire and process code 05 in Section IV-1.C of the questionnaire. Quality assurance was conducted by ensuring that all hydrocracking catalysts previously identified in the questionnaire (i.e., in Section V.B) were assigned in Section VII.2.

---

<sup>5</sup>These percentages do not match up directly with any one of the management scenarios because the number of streams and the volume are a combination of several management scenarios (i.e., Subtitle C landfill, transfer for metals reclamation, etc.).

Based on the results of the questionnaire, 47 facilities use hydrocracking units and are thus likely to generate spent hydrocracking catalyst. Due to the infrequent generation of this residual, not all of these 47 facilities generated spent catalyst in 1992. However, there was no reason to expect that 1992 would not be a typical year with regard to hydrocracking catalyst generation and management. Table 3.3.1 provides a description of the quantity generated, number of streams reported, number of streams not reporting volumes (data requested was unavailable and facilities were not required to generate it), total and average volumes.

**Table 3.3.1. Generation Statistics for Hydrocracking Catalyst, 1992**

<b>Final Management</b>	<b># of Streams</b>	<b># of Streams w/ Unreported Volume</b>	<b>Total Volume (MT)</b>	<b>Average Volume (MT)</b>
Disposal in offsite Subtitle D landfill	7	0	1,592.70	227.53
Disposal in offsite Subtitle C landfill	8	0	991.50	123.94
Reuse onsite as replacement catalyst for another unit	1	0	159.40	159.40
Transfer metal catalyst for reclamation or regeneration	45	2	13,185.56	293.01
Transfer to another petroleum refinery	14	0	2,100.00	150.00
<b>TOTAL</b>	<b>75</b>	<b>2</b>	<b>18,029.16</b>	<b>295.56</b>

### 3.3.2.3 Plausible Management

EPA believes that most of the plausible management practices for this residual were reported in the 1992 RCRA §3007 Survey, as summarized above in Table 3.3.1. The Agency gathered information suggesting other management practices had been used in other years including: “disposal in onsite Subtitle D landfill” (8 MT) and “other recycling, reclamation, or reuse: cement plant” (320 MT). These non-1992 practices are comparable to 1992 practices (i.e., off-site Subtitle D landfilling) or to typical practices for alumina-based catalysts (e.g., cement plants).

The Agency has no other data to suggest other management practices are used for hydrocracking catalysts due to the physical characteristics and chemical composition of the waste. EPA compared the management practice reported for hydrocracking catalysts to those reported for hydrotreating and hydrorefining catalysts based on expected similarities. Similar land disposal practices were reported for all three residuals.

### 3.3.2.4 Characterization

Two sources of residual characterization were developed during the industry study:

- Table 3.3.2 summarizes the physical properties of the spent catalyst as reported in Section VII.A of the §3007 survey.
- Three record samples of spent hydrocracking catalyst were collected and analyzed by EPA and are summarized in Table 3.3.3. The record samples represent the most frequently used catalysts (i.e., nickel/tungsten and nickel/molybdenum, together used

by well over half of the refineries with hydrocracking processes. In addition, heavy gas oil or similar distillate/residual feed is the most common application of hydrocracking reactors, according to the questionnaire. Therefore, the record samples are expected to represent most of the spent catalyst generated in the industry.

However, another frequently used catalyst (palladium) is not represented, and catalysts employing feeds other than heavy gas oil (e.g., lube oil) may not have the same characteristics when spent.

Table 3.3.4 provides a summary of the characterization data collected under this sampling effort. All three record samples were analyzed for total and TCLP levels of volatiles, semivolatiles, metals and ignitability. One of three samples exhibited the ignitability characteristic. Only constituents detected in at least one sample are shown in Table 3.3.4.

**Table 3.3.2. Hydrocracking Catalyst Physical Properties**

Properties	# of Values	# of Unreported Values <sup>1</sup>	10th %	50th %	90th %
pH	39	102	5.00	6.80	9.14
Reactive CN, ppm	21	120	0.30	3.20	10.00
Reactive S, ppm	38	103	1.00	12.50	9,500.00
Flash Point, °C	36	105	60.00	157.50	200.00
Oil and Grease, vol%	17	124	0.00	0.36	9.00
Total Organic Carbon, vol%	14	127	0.00	0.63	8.00
Specific Gravity	54	87	0.80	1.74	3.15
Specific Gravity Temperature, °C	10	131	17.80	20.00	25.00
BTU Content, BTU/lb	4	137	0.00	0.00	7,485.00
Aqueous Liquid, %	64	77	0.00	0.00	0.00
Organic Liquid, %	63	78	0.00	0.00	0.00
Solid, %	101	40	100.00	100.00	100.00
Other, %	62	79	0.00	0.00	0.00
Particle >60 mm, %	28	113	0.00	0.00	0.00
Particle 1-60 mm, %	42	99	95.00	99.00	100.00
Particle 100 µm-1 mm, %	31	110	0.00	1.00	5.00
Particle 10-100 µm, %	27	114	0.00	0.00	0.00
Particle <10 µm, %	27	114	0.00	0.00	0.00
Median Particle Diameter, microns	13	128	0.00	1,600.00	2,000.00

<sup>1</sup>Facilities were not required to do additional testing, therefore information provided was based on previously collected data or engineering judgement.

**Table 3.3.3. Spent Hydrocracking Catalyst Record Sampling Locations**

Sample No.	Facility	Description
R2-CC-01	Shell, Wood River, IL	Nickel/tungsten catalyst, fixed bed, heavy gas oil feed
R8A-CC-01	Amoco, Texas City, TX	Nickel/molybdenum catalyst, moving bed, heavy gas oil feed
R20-CC-01	Star, Convent, LA	Mixed nickel/tungsten and nickel/molybdenum catalyst, moving bed, heavy gas oil feed

### 3.3.2.5 Source Reduction

There is little that can be done to reduce the quantity of these generated catalyst since, by design, they must be periodically replaced with fresh catalyst. As a result, the greatest opportunity for waste minimization arises from sending these materials offsite for metals regeneration, reclamation, or other reuse.

Refinery hydrocracking catalysts generally consist of cobalt and molybdenum or nickel and molybdenum on an alumina support. Typically, the catalysts are regenerated after use. However, industry is interested in finding more specific, long-lasting catalysts. Extensive research is performed in producing new catalysts. Information on hydrotreating and hydrorefining catalysts are also presented below because some of this information may be relevant to hydrocracking catalysts.

Reference	Waste Minimization/Management Methods
Monticello, D.J. "Biocatalytic Desulfurization." <i>Hydrocarbon Processing</i> . February, 1994.	An alternative to metal catalysts is the development of microorganisms that can catalyze the reaction.
"NPRA Q&A 1: Refiners Focus on FCC, Hydroprocessing, and Alkylation Catalyst." <i>Oil &amp; Gas Journal</i> . March 28, 1994.	Methods in improving catalyst life and performance.
Gorra, F., Scribano, G., Christensen, P., Anderson, K.V., and Corsaro, O.G. "New Catalyst, Improve Presulfiding Result in 4+ Year Hydrotreater Run." <i>Oil &amp; Gas Journal</i> . August 23, 1993.	Material substitution to extend catalyst life.
"Petroleum-derived Additive Reduces Coke on Hydrotreating Catalyst." <i>Oil &amp; Gas Journal</i> . December 27, 1993.	Process modification extends life of catalyst.
"Waste Minimization in the Petroleum Industry: A Compendium of Practices." API. November, 1991.	Practices listed: 1. Metals reclamation, 2. Recycling to cement, 3. Recycling to fertilizer plants.

**Table 3.3.4. Spent Hydrocracking Catalyst Characterization**

Volatile Organics - Method 8260A µg/kg							
	CAS No.	R2-CC-02	R8A-CC-01	R20-CC-01	Average Conc	Maximum Conc	Comments
Acetone	67641	5,300	< 6,250	< 1,250	3,275	5,300	1
Acrolein	107028	2,500	< 6,250	< 1,250	1,875	2,500	1
Benzene	71432	370,000	15,000	< 1,250	128,750	370,000	
n-Butylbenzene	104518	10,000	40,000	12,000	20,667	40,000	
sec-Butylbenzene	135988	< 1,250	18,000	13,000	10,750	18,000	
Ethylbenzene	100414	35,000	95,000	< 1,250	43,750	95,000	
Isopropylbenzene	98828	< 1,250	34,000	3,700	17,625	34,000	
p-Isopropyltoluene	99876	< 1,250	28,000	8,500	12,583	28,000	
Naphthalene	91203	< 1,250	64,000	7,600	24,283	64,000	
n-Propylbenzene	103651	5,000	49,000	< 1,250	27,000	49,000	
Toluene	108883	300,000	120,000	< 1,250	140,417	300,000	
1,2,4-Trimethylbenzene	95636	25,000	170,000	21,000	72,000	170,000	
1,3,5-Trimethylbenzene	108678	8,000	48,000	4,200	20,067	48,000	
o-Xylene	95476	23,000	120,000	3,400	48,800	120,000	
m,p-Xylenes	108383 / 106423	60,000	250,000	7,100	105,700	250,000	
TCLP Volatile Organics - Methods 1311 and 8260A µg/L							
	CAS No.	R2-CC-02	R8A-CC-01	R20-CC-01	Average Conc	Maximum Conc	Comments
Benzene	71432	10,000	230	< 50	3,427	10,000	
Ethylbenzene	100414	470	180	< 50	233	470	
Methylene chloride	75092	< 50	250	< 50	117	250	
Toluene	108883	6,600	640	< 50	2,430	6,600	
1,2,4-Trimethylbenzene	95636	J 94	120	J 44	86	120	
1,3,5-Trimethylbenzene	108678	< 50	< 50	J 61	54	61	
o-Xylene	95476	290	270	< 50	203	290	
m,p-Xylene	108383 / 106423	750	410	< 50	403	750	
Semivolatile Organics - Method 8270B µg/kg							
	CAS No.	R2-CC-02	R8A-CC-01	R20-CC-01	Average Conc	Maximum Conc	Comments
Acenaphthene	83329	< 165	20,000	32,000	17,388	32,000	
Benz(a)anthracene	56553	< 165	J 6,900	< 10,313	3,533	6,900	1
Benzofluoranthene (total)	NA	< 165	J 5,000	31,000	12,055	31,000	
Benzo(g,h,i)perylene	191242	< 165	28,000	42,000	23,388	42,000	
Benzo(a)pyrene	50328	< 165	J 3,100	29,000	10,755	29,000	
Carbazole	86748	< 330	74,000	J 24,000	32,777	74,000	
4-Chlorophenyl phenyl ether	7005723	< 165	< 4,125	83,000	29,097	83,000	
Chrysene	218019	< 165	17,000	68,000	28,388	68,000	
Dibenzofuran	132649	1,200	9,700	J 13,000	7,967	13,000	
7,12-Dimethylbenz(a)anthracene	57976	< 165	< 4,125	45,000	16,430	45,000	

**Table 3.3.4. Spent Hydrocracking Catalyst Characterization (continued)**

Semivolatle Organics - Method 8270B µg/kg (continued)							
	CAS No.	R2-CC-02	R8A-CC-01	R20-CC-01	Average Conc	Maximum Conc	Comments
Fluoranthene	206440	< 165	20,000	25,000	15,055	25,000	
Fluorene	86737	2,800	40,000	82,000	41,600	82,000	
Indeno(1,2,3-cd)pyrene	193395	< 165	J 4,600	< 10,313	2,383	4,600	1
3-Methylcholanthrene	56495	< 165	< 4,125	23,000	9,097	23,000	
2-Methylchrysene	3351324	< 330	J 13,000	64,000	25,777	64,000	
1-Methylnaphthalene	90120	< 330	56,000	230,000	95,443	230,000	
2-Methylnaphthalene	91576	< 165	110,000	390,000	166,722	390,000	
2-Methylphenol	95487	< 165	< 4,125	J 7,000	3,763	7,000	
Naphthalene	91203	< 165	43,000	45,000	29,388	45,000	
Phenanthrene	85018	1,200	180,000	160,000	113,733	180,000	
Pyrene	129000	1,600	430,000	680,000	370,533	680,000	
TCLP Semivolatle Organics - Methods 1311 and 8270B µg/L							
	CAS No.	R2-CC-02	R8A-CC-01	R20-CC-01	Average Conc	Maximum Conc	Comments
Carbazole	86748	< 100	J 78	< 100	78	78	1
2,4-Dimethylphenol	105679	< 50	J 23	J 44	34	44	1
1-Methylnaphthalene	90120	< 100	J 24	J 41	33	41	1
2-Methylnaphthalene	91576	< 50	J 46	J 59	52	59	
2-Methylphenol	95487	J 66	J 70	J 25	54	70	
3/4-Methylphenol (total)	NA	J 76	J 49	J 17	47	76	
Naphthalene	91203	< 50	J 44	J 26	35	44	1
Phenol	108952	J 53	< 50	J 63	55	63	
Phenanthrene	85018	< 50	J 23	< 50	23	23	1
Pyrene	129000	< 50	J 42	< 50	42	42	1
Total Metals - Methods 6010, 7060, 7421, 7470, 7471, and 7841 mg/kg							
	CAS No.	R2-CC-02	R8A-CC-01	R20-CC-01	Average Conc	Maximum Conc	Comments
Aluminum	7429905	120,000	53,000	110,000	94,333	120,000	
Antimony	7440360	< 6.0	220	< 6.0	77.3	220	
Arsenic	7440382	12.0	29.0	< 5.0	15.3	29.0	
Beryllium	7440417	< 0.5	160	18.0	59.5	160	
Chromium	7440473	130	68.0	< 1.0	66.3	130	
Cobalt	7440484	24.0	440	< 5.0	156	440	
Copper	7440508	55.0	35.0	< 2.5	30.8	55.0	
Iron	7439896	52,000	2,200	570	18,257	52,000	
Lead	7439921	< 0.3	15.0	1.6	5.6	15.0	
Manganese	7439965	390	16.0	< 1.5	136	390	
Molybdenum	7439987	< 6.5	5,400	17,000	7,469	17,000	
Nickel	7440020	19,000	28,000	27,000	24,667	28,000	



**Table 3.3.4. Spent Hydrocracking Catalyst Characterization (continued)**

Total Metals - Methods 6010, 7060, 7421, 7470, 7471, and 7841 mg/kg (continued)							
	CAS No.	R2-CC-02	R8A-CC-01	R20-CC-01	Average Conc	Maximum Conc	Comments
Selenium	7782492	< 0.5	4.0	< 0.5	1.7	4.0	
Sodium	7440235	1,200	2,000	< 500	1,233	2,000	
Vanadium	7440622	37.0	140,000	49,000	63,012	140,000	
Zinc	7440666	82.0	110	< 2.0	64.7	110	
TCLP Metals - Methods 1311, 6010, 7060, 7421, 7470, 7471, and 7841 mg/L							
	CAS No.	R2-CC-02	R8A-CC-01	R20-CC-01	Average Conc	Maximum Conc	Comments
Aluminum	7429905	26.0	< 1.00	< 1.00	9.33	26.00	
Chromium	7440473	0.35	< 0.05	< 0.05	0.15	0.35	
Iron	7439896	130	< 0.50	< 0.50	43.7	130	
Manganese	7439965	10.0	< 0.08	< 0.08	3.38	10.0	
Nickel	7440020	110	3.60	0.43	38.0	110	
Vanadium	7440622	< 0.25	4.70	< 0.25	1.73	4.70	
Zinc	7440666	0.58	< 0.10	< 0.10	0.26	0.58	
Miscellaneous Characterization							
		R2-CC-02	R8A-CC-01	R20-CC-01			
Ignitability (oF)		138	145	NA			

42 Comments:

- 1 Detection limits greater than the highest detected concentration are excluded from the calculations.

Notes:

- B Analyte also detected in the associated method blank.
- J Compound's concentration is estimated. Mass spectral data indicate the presence of a compound that meets the identification criteria for which the result is less than the laboratory detection limit, but greater than zero.
- ND Not Detected.
- ND Not Applicable.



**STUDY OF SELECTED  
PETROLEUM REFINING RESIDUALS  
  
INDUSTRY STUDY**

Part 2

August 1996

U.S. ENVIRONMENTAL PROTECTION AGENCY  
Office of Solid Waste  
Hazardous Waste Identification Division  
401 M Street, SW  
Washington, DC 20460

### 3.4 ISOMERIZATION

The purpose of isomerization is to increase the refinery's production of high octane, low aromatic gasoline. Gasoline with low benzene and aromatics is newly specified in the California market and is expected to be adopted by other states in the future (*Oil & Gas Journal*, 1995)<sup>1</sup>.

#### 3.4.1 Isomerization Process Description

Principal applications of isomerization at refineries are naphtha isomerization, which produces a gasoline blending component, and butane isomerization, which produces isobutane feed for the alkylation unit. Figure 3.4.1 depicts a generic process flow diagram for isomerization. Based on the results of the RCRA §3007 questionnaire, 65 facilities reported having isomerization units, distributed as follows (some facilities have more than one type of isomerization unit):

- 47 facilities have naphtha isomerization units
- 15 facilities have butane isomerization units
- 7 facilities have other types of isomerization units.

**Figure 1.1.1. Isomerization Process Flow Diagram**

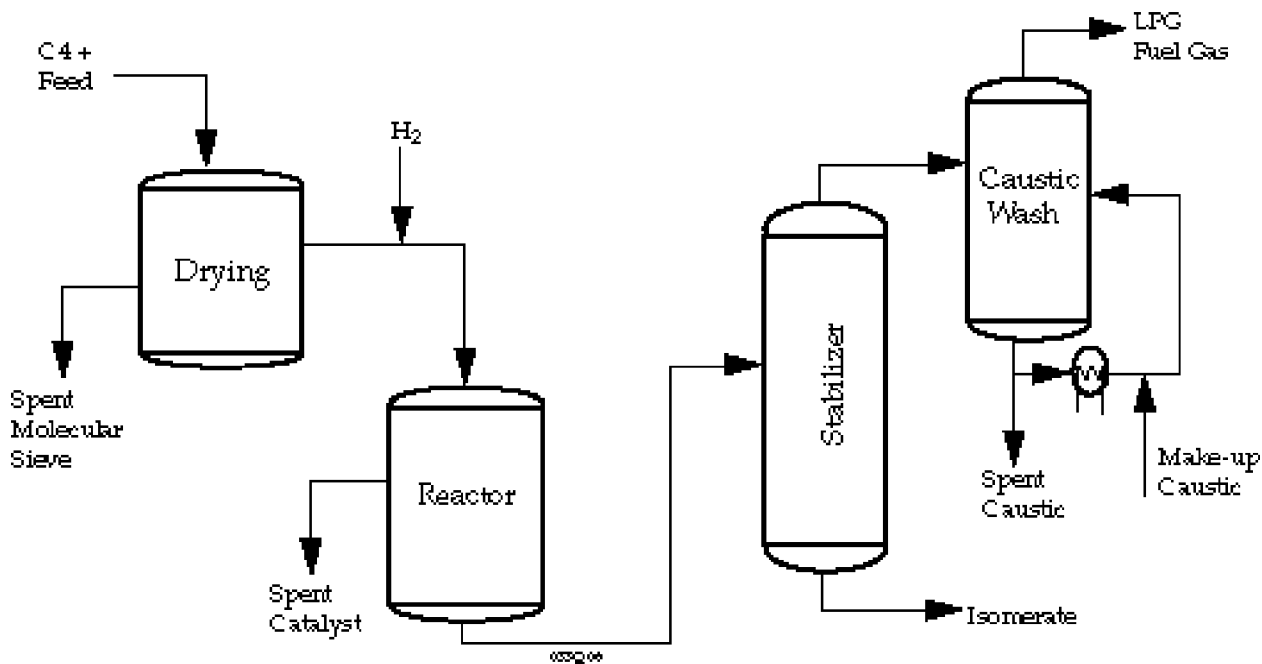

<sup>1</sup>*Oil & Gas Journal*, "Deadline Looming for California Refineries to Supply Phase II RFG," December 11, 1995, pages 21-25.

### 3.4.1.1 Naphtha Isomerization

Gasoline, or naphtha, is generated throughout the refinery and consists of a mix of C<sub>5</sub> and higher hydrocarbons in straight, branched, or ring configuration. Naphtha isomerization converts the straight chains to branched, significantly raising their octane number. A common source of such “low grade” naphtha is light straight run, which consists of the lighter fraction (C<sub>5</sub>/C<sub>6</sub>) of naphtha from atmospheric crude distillation. The reduction of lead in gasoline in the 1970s increased the demand for isomerization technology; prior to that time naphtha isomerization was not widely used (Meyers, 1986).

As found from the RCRA §3007 questionnaire results, the most common naphtha isomerization processes presently used in the industry are UOP's Penex process and Union Carbide's Total Isomerization Process (TIP). Other licensed processes used include the Union Carbide Hysomer process and the BP Isomerization process. In these four processes, naphtha is combined with hydrogen and flows through one or two fixed bed reactors in series; the catalyst consists of a precious metal catalyst on a support (non-precious metal catalysts are rarely, if ever, used for naphtha isomerization). The reactor effluent is sent to a series of columns where hydrogen and fuel gas are separated from the isomerate product. The isomerate, having a significantly higher octane number than the light straight run feed, is charged to the gasoline blending pool. Although the isomerization reaction is not a net consumer or producer of hydrogen, the presence of hydrogen prevents coking and subsequent deactivation of the catalyst (Meyers, 1986).

From a solid waste generation perspective, the principal differences between the various processes relate to the catalyst used; this will in turn affect the feed pretreatment steps and spent catalyst characterization. The two principal types of catalyst identified in the industry are: (1) platinum on zeolite, which operates at temperatures above 200°C, and (2) platinum chloride on alumina, which operates at temperatures below 200°C. The higher temperatures are characteristic of the TIP and Hysomer processes, while the lower temperatures are characteristic of the Penex process and the BP process. The effect of these two different precious metal catalysts on the process are as follows:

- **Dioxin formation.** To maintain an environment of hydrogen chloride in the reactor required for catalyst activity, the platinum chloride catalyst requires a small but continuous addition of a chlorinated organic compound (e.g., carbon tetrachloride) to the feed. Although no oxygen is present during operating conditions, the conditions encountered during unit turnaround and catalyst removal (see Section 3.4.3) could result in dioxin formation. During sampling and analysis, the Agency tested for dioxin and the results are presented in Table 3.4.4.

Unlike reforming unit catalyst (a platinum catalyst discussed in the *Listing Background Document*), the isomerization unit catalyst apparently does not undergo *in situ* regeneration. One refinery stated that they do not conduct regeneration because coke does not form and contaminate the catalyst (making regeneration unnecessary), and design information for these units does not mention *in situ* regeneration.

- **Feed pretreatment.** The platinum chloride catalyst, operating at the lower temperatures, provides better conversion of paraffins to isomers. However, this catalyst is susceptible to water, sulfur, and nitrogen as catalyst poisons (Meyers, 1986). To combat these contaminants, the feed is commonly desulfurized over a cobalt/molybdenum or similar catalyst and generated  $H_2S$  is removed prior to the isomerization reactor. To further protect against sulfur poisoning, some processes include a guard column between the hydrodesulfurization reactor and the isomerization reactor to remove additional sulfur-containing compounds. Rather than consisting of Co/Mo (like many hydrotreating catalysts), this guard column often consists of zinc oxide, nickel on alumina, or copper oxide.

To remove water from the desulfurized naphtha, the hydrocarbon feed is typically dried using molecular sieve. When the molecular sieve is saturated, it is taken off-line for water desorption while the hydrocarbon is rerouted to a parallel molecular sieve vessel. In a similar way, water is removed from the hydrogen feed. Certain molecular sieves can remove both sulfur compounds and water from hydrogen or hydrocarbon feeds.

The platinum on zeolite catalyst is less susceptible to poisoning by these contaminants and reportedly requires none, or significantly less, pretreatment (Meyers, 1986).

Another difference in operating practices found among individual refineries is product stream recycling to increase yield and octane. These qualities can be increased by (1) recycling the paraffins to the reactor following their separation from the isomerized product, or (2) separating (and effectively concentrating) low octane paraffins from other high octane feed components such as isomers and aromatics. These steps can be performed using either conventional fractionation or an adsorbent. In the latter case, the normal paraffins are adsorbed onto zeolite or another adsorbent while the isomers pass through. The paraffins are desorbed and introduced as isomerization reactor feed, while the isomers bypass the isomerization reactor and are introduced to a post reactor stabilizer. Not all refineries conduct such separation, although separation of the feed or product using molecular sieve is integral to the Union Carbide Total Isomerization Process.

#### 3.4.1.2 Butane Isomerization

The purpose of butane isomerization is to generate feed material for a facility's alkylation or MTBE production unit; alkylation unit feed includes isobutane and olefins, while the raw materials used in making MTBE are isobutylene and methanol. Butane isomerization is a much older process than naphtha isomerization, having been used in refineries since World War II. Presently, the most prevalent method of producing isobutane from n-butane is the UOP Butamer process, similar in many ways to the isomerization of naphtha over platinum chloride catalyst. In the Butamer process, normal butane, generated from throughout the refinery and separated from other butanes by distillation, is combined with hydrogen and a chlorinated organic compound. The hydrogen is used to suppress the polymerization of olefin intermediates, while the chlorine source is used to maintain catalyst activity. The feed flows through one or two fixed bed reactors in series, containing platinum chloride on alumina catalyst. The isobutane

product is recovered and used as alkylation unit feed. Butane isomerization takes place at lower temperatures than naphtha isomerization.

Like platinum chloride catalyst used in naphtha isomerization, the Butamer catalyst is poisoned by water and sulfur, as well as fluoride (Meyers, 1986). These compounds are removed from the hydrogen and hydrocarbon feed by molecular sieve.

Although the Butamer process and others using platinum chloride on alumina as a catalyst dominate the industry, other technologies are also used. Three facilities conducting butane isomerization do not use platinum catalysts. Instead, the catalyst is aluminum chloride/hydrochloric acid and generates an almost continuous spent catalyst waste stream in slurry or sludge form.

#### 3.4.1.3 Other Isomerization Processes

Seven facilities reported using isomerization for purposes other than naphtha or butane isomerization. Such applications demonstrate the integration of petroleum refining and chemical production at many refineries. Some of these processes more closely represent petrochemical production than refining processes because they are not widely reported by refineries as a refining step, are not used for fuel production, and produce commodity chemicals. The processes reported by these seven facilities can be classified into three areas:

- **Xylene Isomerization.** Four facilities report processes to convert xylene isomers (e.g., from an extraction process) to p- and/or o-xylene. Unlike the naphtha and butane isomerization units described above, the catalyst is not precious metal. The xylene products are sold.
- **Cyclohexane Isomerization.** Two facilities produce cyclohexane from raw materials that include benzene and hydrogen. Unlike the naphtha and butane isomerization units described above, the catalyst is not precious metal.
- **Butylene Isomerization.** Two facilities produce butylene from various C<sub>4</sub> olefins. Butylene is used for feed to the alkylation unit. A precious metal (palladium) catalyst is used.

### 3.4.2 Isomerization Catalyst

#### 3.4.2.1 Description

As discussed in Section 3.4.1, the most prevalent catalyst used for both butane and naphtha isomerization is platinum or platinum chloride on alumina or zeolite. When the catalyst loses activity, it is removed from the reactor and replaced with fresh catalyst. Prior to removal, the reactor may be swept to remove hydrocarbons from the catalyst. These preparation steps can include one or more of the following:

- Nitrogen sweep (to remove hydrocarbon)
- Oxygen sweep (to burn hydrocarbon)

- Steam stripping (to remove hydrocarbon).

This procedure of catalyst preparation, removal, and replacement is relatively lengthy (typically one week or more) and requires the unit, or at least the reactor, to be shut down such that no hydrocarbon is processed during the time of catalyst replacement.

There are a handful of isomerization processes used at domestic refineries that do not use platinum or platinum chloride catalyst. At these facilities, spent catalyst is generated in one of the following two methods:

- A method similar to the generation of spent platinum/platinum chloride catalyst described above. Fixed-bed processes are used in both palladium and non-precious metal catalyst applications and spent solid catalyst is infrequently removed.
- A method where catalyst is removed from the fixed-bed reactor frequently (up to once a day) in liquid/semi-solid form, presumably with little to no disruption of the process. This method is used only for one process which uses aluminum chloride/hydrochloric acid catalyst.

Another type of catalyst seen in conjunction with an isomerization unit is desulfurization catalyst. In many naphtha isomerization processes, the feed typically contains high levels of mercaptans which are converted to H<sub>2</sub>S over a non-precious metal catalyst, such as cobalt/molybdenum. Such catalysts were discussed in the Listing Background Document under the broad name of “hydrotreating catalysts” and will not be discussed here.

#### 3.4.2.2 Generation and Management

The spent catalyst is vacuumed or gravity dumped from the reactors. Based on information from site visits, most refineries place the material directly into closed containers such as 55-gallon drums, flow-bins, or 1 cubic yard “supersacks.” The frequency of generation is typically between 2 and 10 years, with a small number of facilities generating a slurry/sludge continuously. In 1992, only one facility reported classifying this residual as RCRA hazardous (this facility classified 2 MT as D001).<sup>2</sup> In other years, some facilities reported that this residual carried a RCRA hazardous waste code of D018 (TCLP benzene).

Eighteen facilities reported generating a total quantity of 337 MT of this residual in 1992, according to the 1992 RCRA §3007 Questionnaire. The questionnaire reported that 65 facilities have isomerization units and thus are likely to generate spent isomerization catalyst at some time. Due to the infrequent generation of this residual, not all of these 65 facilities generated spent catalyst in 1992. However, there was no reason to expect that 1992 would not be a typical year with regard to this residual's generation and management.

---

<sup>2</sup>These percentages do not match up directly with any one of the management scenarios because the number of streams and the volume are a combination of several management scenarios (i.e., Subtitle C landfill, transfer for metals reclamation, etc.).





Residuals were assigned to be “spent isomerization catalyst” if they were assigned a residual identification code of “spent solid catalyst” and were generated from a process identified as an isomerization unit. These correspond to residual code 03-A in Section VII.A of the questionnaire and process code 10 in Section IV.C of the questionnaire. The small volume of continuously generated residuals (discussed in Section 3.4.3.1) were typically omitted from these statistics, because they were most often characterized as sludges. However, as stated in Section 3.4.1, some nonprecious metal catalysts are also used in fixed bed processes and are included in these statistics. Table 3.4.1 provides a description of the 1992 management practices, quantity generated, number of streams reported, number of streams not reporting volumes (data requested was unavailable and facilities were not required to generate it), total and average volumes.

**Table 3.4.1. Generation Statistics for Catalyst from Isomerization, 1992**

Final Management	# of Streams	# of Streams w/ Unreported Volume	Total Volume (MT)	Average Volume (MT)
Disposal in offsite Subtitle C landfill	3	0	43.79	14.60
Transfer metal catalyst for reclamation or regeneration	17	0	293.40	17.26
TOTAL	20	0	337.19	16.86

### 3.2.2.3 Plausible Management

EPA believes that most of the plausible management practices for this residual were reported in the 1992 RCRA §3007 Survey, as summarized above in Table 3.4.1. The Agency assessed information reported for other years but no additional management practices were reported for this residual. In addition, EPA compared the management practice reported for isomerization catalysts to those reported for reforming catalysts (a listing residual described in the Listing Background Document) based on expected similarities. The vast majority of both wastes are reclaimed due to their precious metal content.

### 3.4.2.4 Characterization

Two sources of residual characterization were developed during the industry study:

- Table 3.4.2 summarizes the physical properties of the spent catalyst as reported in Section VII.A of the §3007 survey.
- Four record samples of spent isomerization catalyst were collected and analyzed by EPA. These spent catalysts represent the majority of processes used by the industry. Sampling information is summarized in Table 3.4.3.

**Table 3.4.2. Catalyst from Isomerization: Physical Properties**

Properties	# of Values	# of Unreported Values <sup>1</sup>	10th %	50th %	90th %
pH	20	51	3.35	4.50	7.75
Reactive CN, ppm	14	57	0.04	1.00	11.60
Reactive S, ppm	16	55	0.90	3.00	100.00
Flash Point, °C	15	56	60.00	100.00	200.00
Oil and Grease, vol%	14	56	0.00	0.50	1.00
Total Organic Carbon, vol%	13	58	0.00	0.20	3.00
Specific Gravity	23	48	0.65	1.08	3.00
Aqueous Liquid, %	32	39	0.00	0.00	0.00
Organic Liquid, %	32	39	0.00	0.00	1.00
Solid, %	52	19	95.00	100.00	100.00
Other, %	29	42	0.00	0.00	0.00
Particle >60 mm, %	11	60	0.00	0.00	100.00
Particle 1-60 mm, %	22	49	0.00	100.00	100.00
Particle 100 µm-1 mm, %	13	58	0.00	0.00	1.00
Particle 10-100 µm, %	13	58	0.00	0.00	5.00
Particle <10 µm, %	11	60	0.00	0.00	0.00
Median Particle Diameter, microns	9	62	0.00	1,590.00	2,000.00

<sup>1</sup>Facilities were not required to do additional testing, therefore information provided was based on previously collected data or engineering judgement.

**Table 3.4.3. Spent Isomerization Catalyst Record Sampling Locations**

Sample number	Facility	Description: Process Name/Catalyst Type
R5B-IC-01	Marathon, Garyville LA	Butane isomerization (UOP Butamer process), platinum chloride catalyst
R8B-IC-01	Amoco, Texas City TX	Naphtha isomerization (UOP Penex process), platinum chloride catalyst
R18-IC-01	Ashland, Canton OH	Naphtha isomerization (UOP Penex process), platinum chloride catalyst
R23B-IC-01	Chevron, Salt Lake City, UT	Butane isomerization (UOP Butamer process), platinum chloride catalyst

The collected samples are expected to be representative of processes using platinum chloride catalyst. Other processes use platinum catalyst or (rarely) non-precious metal catalysts. Because similar feeds are processed by most isomerization processes, these spent catalysts are expected to display similar characteristics, with the following exceptions: (1) spent platinum chloride catalysts (and possibly aluminum chloride/hydrogen chloride catalysts) are the only catalysts expected to contain dioxins, because of the presence of chlorine in the process, (2) platinum chloride catalysts require cleaner feed (i.e., water and sulfur are catalyst poisons), and thus concentrations of some contaminants may be greater in spent catalysts from processes not using platinum chloride catalysts.

All four record samples were analyzed for total and TCLP levels of volatiles, semivolatiles, metals, and reactivity (pyrophoricity). Three samples were analyzed for total levels of dioxins/furans. Three of the four samples were found to exhibit the toxicity characteristic for benzene (i.e., the level of benzene in these samples' TCLP extracts exceeded the corresponding regulatory level). A summary of the analytical results is presented in Table 3.4.4. Only constituents detected in at least one sample are shown in this table.

#### 3.4.2.5 Source Reduction

As in the case of the hydrocracking catalyst, source reduction methods are those that extend the life of the catalyst. Currently, recycling of the spent catalyst by sending to metals reclamation is a common practice since the catalyst is platinum.

Reference	Waste Minimization Methods
J. Liers, J. Mensinger, A. Mosch, W. Reschefilowski. "Reforming Using Erionite Catalysts." <i>Hydrocarbon Processing</i> . Aug. 1993.	The platinum catalyst together with erionite increases isomerization.

**Table 3.4.4. Residual Characterization Data for Spent Isomerization Catalyst**

Petroleum Refining Industry Study

58

Volatile Organics - Method 8260A µg/kg										
	CAS No.	R5B-IC-01	R8B-IC-01	R18-IC-01	R23B-IC-01	Average Conc	Maximum Conc	Comments		
Acetone	67641	< 625	< 625	B 1,200	< 15,625	817	1,200	1		
Benzene	71432	24,000	19,000	280,000	< 15,625	84,656	280,000			
tert-Butylbenzene	98066	< 625	< 625	1,900	< 15,625	1,050	1,900	1		
Chlorobenzene	108907	< 625	15,000	J 580	< 15,625	5,402	15,000	1		
Chloromethane	74873	3,700	1,900	2,800	150,000	39,600	150,000			
2-Chlorotoluene	95498	< 625	< 625	1,900	< 15,625	1,050	1,900	1		
4-Chlorotoluene	106434	< 625	< 625	1,300	< 15,625	850	1,300	1		
1,4-Dichlorobenzene	106467	< 625	J 730	< 600	< 15,625	652	730	1		
Ethylbenzene	100414	< 625	< 625	63,000	< 15,625	19,969	63,000			
Isopropylbenzene	98828	< 625	< 625	J 520	< 15,625	520	520	1		
n-Propylbenzene	103651	< 625	< 625	1,800	< 15,625	1,017	1,800	1		
Methyl ethyl ketone	78933	< 625	< 625	B 1,200	< 15,625	817	1,200	1		
Toluene	108883	< 625	J 500	270,000	< 15,625	71,688	270,000			
1,2,4-Trimethylbenzene	95636	< 625	1,500	3,800	< 15,625	1,975	3,800	1		
1,3,5-Trimethylbenzene	108678	< 625	J 540	< 600	< 15,625	540	540	1		
o-Xylene	95476	< 625	< 625	29,000	< 15,625	11,469	29,000			
m,p-Xylenes	108383 / 106423	< 625	J 720	190,000	< 15,625	51,743	190,000			
Naphthalene	91203	< 625	1,900	< 600	J 9,800	3,231	9,800			
TCLP Volatile Organics - Methods 1311 and 8260A µg/L										
	CAS No.	R5B-IC-01	R8B-IC-01	R18-IC-01	R23B-IC-01	Average Conc	Maximum Conc	Comments		
Acetone	67641	< 50	< 50	B 180	< 50	83	180			
Benzene	71432	1,700	1,400	8,800	< 50	2,988	8,800			
Chlorobenzene	108907	< 50	220	< 50	< 50	93	220			
2-Chlorotoluene	95498	< 50	< 50	J 33	< 50	33	33	1		
4-Chlorotoluene	106434	< 50	< 50	J 21	< 50	21	21	1		
Ethylbenzene	100414	< 50	< 50	1,500	< 50	413	1,500			
Methylene chloride	75092	< 50	B 3,500	J 23	< 50	906	3,500			
Methyl ethyl ketone	78933	< 50	< 50	J 42	< 50	42	42	1		
Toluene	108883	< 50	J 48	8,300	< 50	2,112	8,300			
1,2,4-Trimethylbenzene	95636	< 50	< 50	J 55	< 50	51	55			
o-Xylene	95476	< 50	< 50	930	< 50	270	930			
m,p-Xylene	108383 / 106423	< 50	< 50	3,800	< 50	988	3,800			
Naphthalene	91203	< 50	< 50	< 50	J 26	26	26	1		

August 1996

**Table 3.3.4. Residual Characterization Data for Spent Isomerization Catalyst (continued)**

Petroleum Refining Industry Study

59

Semivolatile Organics - Method 8270B µg/kg								
	CAS No.	R5B-IC-01	R8B-IC-01	R18-IC-01	R23B-IC-01	Average Conc	Maximum Conc	Comments
Bis(2-ethylhexyl) phthalate	117817	< 165	J 410	710	< 165	363	710	
7,12-Dimethylbenz(a)anthracene	57976	J 73	J 600	< 165	< 165	251	600	
Isophorone	78591	1,200	15,000	J 220	2,700	4,780	15,000	
2,4-Dimethylphenol	105679	< 165	< 413	1,000	< 165	436	1,000	
2-Methylphenol	95487	< 165	< 413	640	< 165	346	640	
3/4-Methylphenol	NA	< 165	< 413	1,500	< 165	561	1,500	
Phenol	108952	< 165	< 413	1,700	< 165	611	1,700	
TCLP Semivolatile Organics - Methods 1311 and 8270B µg/L								
	CAS No.	R5B-IC-01	R8B-IC-01	R18-IC-01	R23B-IC-01	Average Conc	Maximum Conc	Comments
Bis(2-ethylhexyl) phthalate	117817	< 50	< 25,000	J 18	< 50	18	18	1, 2
Di-n-butyl phthalate	84742	J 31	< 25,000	J 50	< 50	44	50	2
2,4-Dimethylphenol	105679	< 50	320,000	J 53	< 50	51	53	2
2-Methylphenol	95487	< 50	140,000	140	< 50	80	140	2
3/4-Methylphenol (total)	NA	< 50	870,000	240	< 50	113	240	2
Phenol	108952	< 50	< 25,000	840	< 50	313	840	2
Isophorone	78591	< 50	J 6,700	< 50	< 50	NA	NA	2
Total Metals - Methods 6010, 7060, 7421, 7470, 7471, and 7841 mg/kg								
	CAS No.	R5B-IC-01	R8B-IC-01	R18-IC-01	R23B-IC-01	Average Conc	Maximum Conc	Comments
Aluminum	7429905	460,000	130,000	260,000	230,000	270,000	460,000	
Arsenic	7440382	< 1.00	< 1.00	26.0	< 1.00	7.25	26.0	
Chromium	7440473	20.0	17.0	17.0	17.0	17.8	20.0	
Copper	7440508	< 2.50	< 2.50	< 2.50	5.50	3.25	5.50	
Iron	7439896	< 10.0	54.0	190	73.0	81.8	190	
Nickel	7440020	14.0	10.0	< 4.00	< 4.00	8.00	14.0	
Zinc	7440666	< 2.00	< 2.00	< 2.00	9.2	3.80	9.20	
TCLP Metals - Methods 1311, 6010, 7060, 7421, 7470, 7471, and 7841 mg/L								
	CAS No.	R5B-IC-01	R8B-IC-01	R18-IC-01	R23B-IC-01	Average Conc	Maximum Conc	Comments
Aluminum	7429905	620	560	380	450	503	620	
Chromium	7440473	< 0.05	< 0.05	0.13	< 0.05	0.07	0.13	
Iron	7439896	2.40	< 0.50	7.60	< 0.50	2.75	7.60	
Lead	7439921	< 0.015	< 0.015	0.045	< 0.015	0.023	0.045	
Manganese	7439965	< 0.08	< 0.08	0.42	< 0.08	0.16	0.42	
Zinc	7440666	B 0.45	B 0.41	B 0.70	B 0.53	0.52	0.70	

August 1996

**Table 3.3.4. Residual Characterization Data for Spent Isomerization Catalyst (continued)**

Dioxins/Furans - Method 8290 ng/kg									
	CAS No.	R5B-IC-01	R8B-IC-01	R18-IC-01	R23B-IC-01	Average Conc	Maximum Conc	Comments	
2,3,7,8-TCDF	51207319	< 0.13	< 0.20	B 0.69	NA	0.34	0.69		
Total TCDF	55722275	< 0.13	< 0.20	B 0.69	NA	0.34	0.69		
2,3,4,6,7,8-HxCDF	60851345	0.32	< 0.34	< 0.50	NA	0.32	0.32	1	
Total HxCDF	55684941	B 0.32	< 0.34	< 0.50	NA	0.32	0.32	1	
1,2,3,4,6,7,8-HpCDF	67562394	0.42	< 0.26	< 0.37	NA	0.35	0.42		
Total HpCDF	38998753	2.10	< 0.26	< 0.37	NA	0.91	2.10		
1,2,3,4,6,7,8-HpCDD	35822469	3.00	< 0.60	< 0.50	NA	1.37	3.00		
Total HpCDD	37871004	B 3.00	< 0.60	< 0.50	NA	1.37	3.00		
OCDF	39001020	3.70	< 0.80	< 0.55	NA	1.68	3.70		
OCDD	3268879	B 43.0	B 1.70	B 1.70	NA	15.47	43.00		
2,3,7,8-TCDD Equivalence	1746016	0.11	0.0017	0.071	NA	0.06	0.11		

Comments:

- 1 Detection limits greater than the highest detected concentration are excluded from the calculations.
- 2 TCLP Semivolatile Organic results for sample R8B-IC-01 are excluded from the calculations.

Notes:

- 60
- B Analyte also detected in the associated method blank.
  - J Compound's concentration is estimated. Mass spectral data indicate the presence of a compound that meets the identification criteria for which the result is less than the laboratory detection limit, but greater than zero.
  - NA Not Applicable.

### 3.4.3 Isomerization Treating Clay

#### 3.4.3.1 Description

Not all facilities with isomerization units use “treating clay,” or adsorbents. However, solid adsorbents can be used in three places in the isomerization process:

- **Hydrocarbon feed purification.** Processes using platinum chloride catalysts require a purified feed. Both spent molecular sieve (for drying) and spent metal-alumina (for sulfur removal) are generated.
- **Hydrogen feed purification.** Processes using platinum chloride catalysts require dry hydrogen gas. Spent molecular sieve is generated.
- **Paraffin separation of the feed or product.** Various types of processes use adsorbents for paraffin separation. Molecular sieve is the most common adsorbent for this application.

All of these adsorbents go through adsorption/desorption cycles. Over time, the adsorbent loses its capacity or efficiency and is removed from the vessel and replaced with fresh adsorbent. Prior to removal, the vessel can be swept to remove light hydrocarbons and hydrogen sulfide from the vessel. Typically, processes use adsorbent beds in parallel so that one bed can be on-line (adsorption mode) while the second is off-line for desorption or replacement.

#### 3.4.3.2 Generation and Management

When spent, adsorbents from isomerization are vacuumed or gravity dumped from the vessels. Interim storage can include 55-gallon drums, flow-bins, dumpsters, or piles. The frequency of generation is highly dependent on the generating process: isomerization adsorbents are typically generated approximately every 5 years, while extraction clay is typically generated once per year or less. According to questionnaire results, 6 facilities reported classifying 39.5 MT of this residual as RCRA hazardous in 1992 (most typically as D018, D001, and D006).<sup>3</sup> This is consistent with reporting for other years.

Twenty-two facilities reported generating a total quantity of approximately 597 MT of this residual in 1992, according to the 1992 RCRA §3007 Questionnaire. The questionnaire reported that 65 facilities have isomerization units. However, not all of these facilities use clay, molecular sieve, or other adsorbents in their process; 25 percent of facilities with isomerization units did not report generating any clay residual for their process in any year, indicating either that clay is either not used, has not yet been replaced, or is generated so infrequently that respondents could not recall when, if ever, the clay was last replaced. In addition, these adsorbents may be replaced less often than once per year or not in 1992, particularly those

---

<sup>3</sup>These percentages do not match up directly with any one of the management scenarios because the number of streams and the volume are a combination of several management scenarios (i.e., Subtitle C landfill, transfer for metals reclamation, etc.).



associated with the isomerization process. However, there was no reason to expect that 1992 would not be a typical year with regard to this residual's generation and management.

Residuals were assigned to be “spent clay from isomerization” if they were assigned a residual identification code of “spent sorbent” and were generated from a process identified as an isomerization or extraction unit. These correspond to residual code 07 in Section VII.A of the questionnaire and process code 10 in Section IV.C of the questionnaire. Table 3.4.5 provides a description of the 1992 management practices, quantity generated, number of streams reported, number of streams not reporting volumes (data requested was unavailable and facilities were not required to generate it), total and average volumes.

**Table 3.4.5. Generation Statistics for Treating Clay from Isomerization, 1992**

Final Management	# of Streams	# of Streams w/ Unreported Volume	Total Volume (MT)	Average Volume (MT)
Disposal in offsite Subtitle D landfill	14	0	202	14.4
Disposal in offsite Subtitle C landfill	6	0	140	23.3
Disposal in onsite Subtitle C landfill	1	0	18	18
Disposal in onsite Subtitle D landfill	2	0	46.8	23.4
Other discharge or disposal offsite: broker	2	0	14	7
Other recycling, or reuse: cement plant	2	0	2.5	1.25
Other recycling, or reuse: onsite road material	4	0	138	34.5
Storage in pile	7	0	19.7	2.8
Transfer metal catalyst for reclamation or regeneration	5	0	15	3
TOTAL	43	0	596	13.8

### 3.4.3.3 Plausible Management

EPA believes that most of the plausible management practices for this residual were reported in the 1992 RCRA §3007 Survey, as summarized above in Table 3.4.5. The Agency gathered information from other years but no additional management practices were reported for this residual. In addition, EPA compared the management practice reported for isomerization treating clay to those reported for treating clays from extraction, alkylation, and lube oil<sup>4</sup> based on expected similarities. Land treatment was reported for these other types of treating clays, therefore it is likely that land treatment is a plausible management practice for clays from isomerization.

---

<sup>4</sup>EPA did not compare these management practices to those reported for the broader category of “treating clay from clay filtering” due to the diverse types of materials included in this miscellaneous category.

#### 3.4.3.4 Characterization

Two sources of residual characterization were developed during the industry study:

- Table 3.4.6 summarizes the physical properties of the spent adsorbents as reported in Section VII.A of the §3007 survey.
- One record sample of spent adsorbents from isomerization were collected and analyzed by EPA. The isomerization treating clay was categorized with the extraction clay in the consent decree, therefore, the sampling information is summarized with the extraction clay in Table 3.4.7.

The one record sample was analyzed for total and TCLP levels of volatiles, semivolatiles, and metals, and ignitability. The sample was not found to exhibit a hazardous waste characteristic. A summary of the results is presented in Table 3.4.7. Only constituents detected in at least one sample are shown in this table.

#### 3.4.3.5 Source Reduction

Treating clay for isomerization is generally used as a method of prolonging the life of the catalyst or for product polishing. Because they are used as a source reduction technique for other residuals, no source reduction methods for the clays were found.

**Table 3.4.6. Treating Clay from Isomerization: Physical Properties**

Properties	# of Values	# of Unreported Values <sup>1</sup>	10th %	50th %	90th %
pH	37	71	5.9	7	9.4
Reactive CN, ppm	22	86	0	1	10
Reactive S, ppm	27	81	0	1	100
Flash Point, °C	20	88	19.17	60	131.7
Oil and Grease, vol%	20	85	0	0.75	1.5
Total Organic Carbon, vol%	18	87	0	0.18	2
Specific Gravity	31	77	0.8	1.2	2.2
Aqueous Liquid, %	50	58	0	0	3.5
Organic Liquid, %	51	57	0	0	0.1
Solid, %	75	33	97.5	100	100
Particle >60 mm, %	22	86	0	0	100
Particle 1-60 mm, %	32	76	0	100	100
Particle 100 µm-1 mm, %	23	85	0	0	7.5
Particle 10-100 µm, %	20	88	0	0	0
Particle <10 µm, %	20	88	0	0	0
Median Particle Diameter, microns	9	98	0	2	3000

<sup>1</sup>Facilities were not required to do additional testing, therefore information provided was based on previously collected data or engineering judgement.

**Table 3.4.7. Isomerization Spent Sorbent Record Sampling Locations**

Sample number	Facility	Description
R23B-CI-01	Chevron, Salt Lake City UT	Molecular sieve, drying butane feed prior to isomerization

### 3.5 EXTRACTION

Extraction processes separate more valuable chemical mixtures from a mixed aromatic and paraffinic stream. At refineries, extraction processes most commonly fall into two types: (1) “heavy end” extraction, commonly used in lube oil manufacture and deasphalting operations to upgrade and further process gas oils, and (2) gasoline component extraction, commonly used to separate some of the more valuable aromatics from naphtha. “Heavy end” extraction is discussed with other residual upgrading technologies in Section 3.8 of this document. The gasoline component extraction processes are discussed here.

#### 3.5.1 Extraction Process Description

Thirty facilities reported using gasoline component extraction processes in their refineries. By far the most common type of gasoline component extraction process conducted at refineries, according to the RCRA §3007 questionnaire, is the recovery of benzene, toluene, and mixed xylenes from reformat (i.e., the product from a catalytic reforming unit) for sales or further processing. Most extraction units actually consist of two sections in series: an extraction section, which separates aromatics from non-aromatics using continuous liquid-liquid extraction, and a distillation section, which separates the various aromatic compounds from each other in a series of fractionation towers. Figure 3.5.1 depicts a generic extraction process flow diagram.

Figure 1.2.1. Extraction Process Flow Diagram

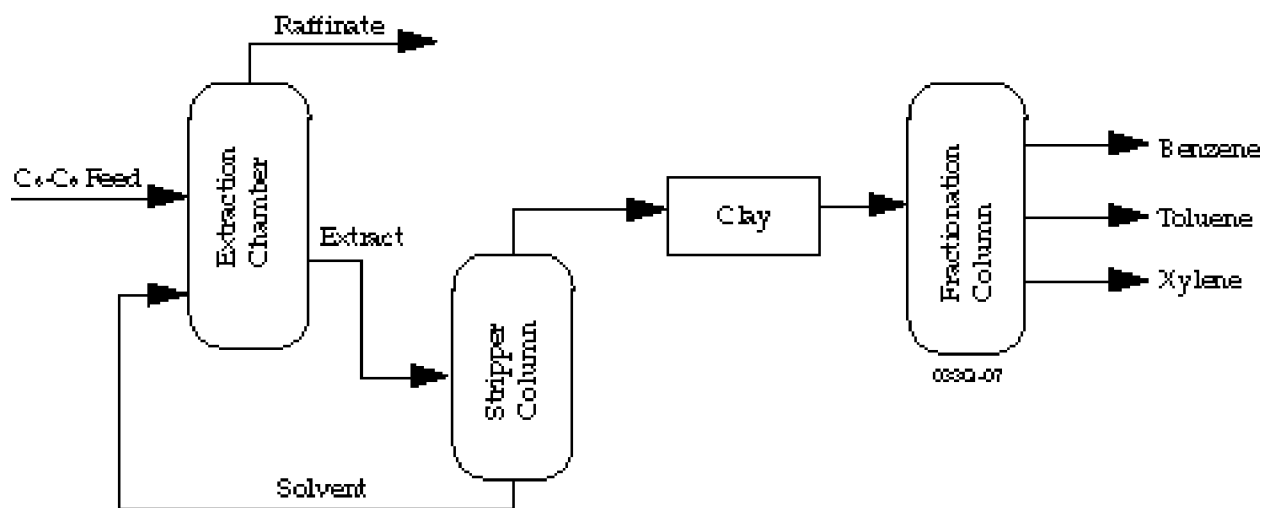

In the extraction section, the charge is countercurrently contacted with a solvent. The solvent is most commonly sulfolane,  $C_4H_8SO_2$ , or tetraethylene glycol,  $O(CH_2CH_2OCH_2CH_2OH)_2$ , although a small number of facilities use diglycol amine,  $O(CCO)CCN$ . The raffinate is separated from the aromatic-rich solvent in a tower. The aromatic-poor raffinate is water-washed to remove solvent and used elsewhere in the refinery. The aromatic-rich extract is also water-washed to remove solvent and the aromatics sent to the distillation section for separation into benzene, toluene, and xylenes.

In the distillation section, the aromatic extract is distilled to remove benzene from the top of the column; the bottoms are sent to the next column. In successive columns, toluene and finally xylene are removed. The bottoms from the xylene tower (C<sub>9</sub> aromatics) are sent to gasoline blending. Some facilities omit the distillation section altogether, using their extraction unit simply to produce low and high octane blending stocks.

To decrease the unit's loading, the feed can be separated prior to extraction so that only the most desirable fractions, such as C<sub>6</sub> to C<sub>8</sub>, are upgraded. This eliminates a final distillation step and eliminates a heavy aromatic stream as a product from the benzene-toluene-xylene separation.

Several other gasoline component extraction processes are each reported by only 1 or 2 refineries in the industry. Other refineries may use these processes, but did not report them because of their resemblance to petrochemical operations of solvent manufacture, etc., which some refineries considered out of the survey scope. As a result, the database may not accurately reflect the incidence of these processes. These processes are as follows:

- The UOP Parex process separates p-xylene from mixed C<sub>8</sub> aromatics. C<sub>8</sub> feed is injected countercurrently to a bed of solid adsorbent, which adsorbs p-xylene. The bed is then desorbed and the p-xylene is recovered in the extract for use in petrochemical production. This process is typically associated with a xylene isomerization process (Meyers, 1986). This arrangement differs from the overwhelming majority of extraction processes, which are associated with reforming processes.
- The Union Carbide IsoSiv process separates normal C<sub>6</sub>-C<sub>8</sub> paraffins from the other branched and ring compounds present in light straight run. In this process, the paraffins are adsorbed onto a fixed bed of molecular sieve. The paraffins are desorbed and used as petrochemical feedstock, solvents, etc., while the branched and ring compounds are used for gasoline blending (Meyers, 1986).
- One facility uses a process similar to the gasoline component extraction process described above, but with a slightly heavier feed.
- Heavy naphtha is fed to a fixed bed of silica gel. Aromatics are adsorbed while paraffins pass through. When saturated, the bed is desorbed with benzene and the product distilled to form various solvents. No other adsorbents are used in the process.

### 3.5.2 Extraction Treating Clay

#### 3.5.2.1. Description

Wastes generated from the reformate extraction processes include the following:

- **"Fuel side."** Treating clay is used to remove impurities from the hydrocarbon following extraction; the most common application is the filtering of the aromatic fraction prior to benzene distillation (to keep impurities out of the downstream fractions), although a small number of facilities use the clay to filter the benzene

product stream only. The purpose of the clay is to remove olefins, suspended solids, and trace amount of solvent by a combination of adsorption and catalytic processes. A few facilities also treat the raffinate (non-aromatic) stream with clay. Many facilities did not report a clay treating step anywhere in their reformate extraction process. For these facilities, clay treating is evidently not required to achieve the target product limits.

- **”Solvent side.”** Various treatment methods are used to remove impurities such as polymers and salts from the lean solvent. A slip stream of lean solvent is processed using ion-exchange, sock filters, carbon adsorption, or regeneration. This is similar to the methods used to treat amine in sulfur-removal systems. An intermittent stream of spent solvent can sometimes be generated.

Only the “fuel side” residuals are discussed and evaluated in Section 3.4.4. The “solvent side” residuals are generally classified as miscellaneous sludges in the database and their volumes were not tabulated in Table 3.5.1 (below).

As stated above, reformate extraction is the most common type of gasoline component extraction process, but the small number of other processes also generate spent adsorbents. These processes are unlike reformate extraction because the adsorbent is used for aromatic separation (in reformate extraction, clay treatment occurs following aromatic extraction). In these processes, spent adsorbent is also periodically generated, although generally less frequently so than in the reformate extraction process. These materials were included in the statistics presented in Table 3.5.1.

### 3.5.2.2 Generation and Management

When spent, adsorbents from extraction are vacuumed or gravity dumped from the vessels. Interim storage can include 55-gallon drums, flow-bins, dumpsters, or piles. The frequency of generation is highly dependent on the generating process: extraction clay is typically generated once per year or less. According to questionnaire results, 2 facilities reported classifying 81.3 MT of this residual as RCRA hazardous in 1992 (as D018).<sup>5</sup> This is consistent with reporting for other years.

Fifteen facilities reported generating a total quantity of approximately 1900 MT of this residual in 1992, according to the 1992 RCRA §3007 Questionnaire. The questionnaire reported that 30 facilities have extraction units. However, not all of these facilities use clay, molecular sieve, or other adsorbents in their process; 33 percent of facilities with extraction units did not report generating any clay residual for their process in any year, indicating either that clay is either not used, has not yet been replaced, or is generated so infrequently that respondents could not recall when, if ever, the clay was last replaced. However, there was no reason to expect that 1992 would not be a typical year with regard to this residual's generation and management. Extraction clays are generated more frequently and in greater quantity than isomerization clays.

---

<sup>5</sup>These percentages do not match up directly with any one of the management scenarios because the number of streams and the volume are a combination of several management scenarios (i.e., Subtitle C landfill, transfer for metals reclamation, etc.).

Residuals were assigned to be “spent clay from extraction” if they were assigned a residual identification code of “spent sorbent” and were generated from a process identified as an isomerization or extraction unit. These correspond to residual code 07 in Section VII.A and process codes 12 in Section IV.C of the survey. Table 3.5.1 provides a description of the 1992 management practices, quantity generated, number of streams reported, number of streams not reporting volumes (data requested was unavailable and facilities were not required to generate it), total and average volumes.

**Table 3.5.1. Generation Statistics for Treating Clay from Extraction, 1992**

<b>Final Management</b>	<b># of Streams</b>	<b># of Streams w/ Unreported Volume</b>	<b>Total Volume (MT)</b>	<b>Average Volume (MT)</b>
Disposal in offsite Subtitle D landfill	10	0	734.8	88.4
Disposal in offsite Subtitle C landfill	4	0	376.3	94
Disposal in onsite Subtitle C landfill	1	0	40	40
Disposal in onsite Subtitle D landfill	2	0	448.8	224.4
Onsite land treatment	3	0	231	78
Other recycling, or reuse: cement plant	1	0	26	26
Transfer metal catalyst for reclamation or regeneration	1	0	18	18
<b>TOTAL</b>	<b>22</b>	<b>0</b>	<b>1875</b>	<b>85.2</b>

### 3.5.2.3 Plausible Management

EPA believes that most of the plausible management practices for this residual were reported in the 1992 RCRA §3007 Survey, as summarized above in Table 3.5.1. The Agency gathered information suggesting that “offsite land treatment” (95 MT) was used in other years. This practice is comparable to the practice reported for 1992 (i.e., onsite land treatment). In addition, EPA compared the management practice reported for extraction treating clay to those reported for treating clays from isomerization, alkylation, and lube oil<sup>6</sup> based on expected similarities. No additional management practices were reported.

---

<sup>6</sup>EPA did not compare these management practices to those reported for the broader category of “treating clay from clay filtering” due to the diverse types of materials included in this miscellaneous category.

#### 3.5.2.4 Characterization

Two sources of residual characterization were developed during the industry study:

- Table 3.5.2 summarizes the physical properties of the spent adsorbents as reported in Section VII.A of the §3007 survey.
- One record sample of spent adsorbents from extraction was collected and analyzed by EPA. The sampling information is summarized in Table 3.5.3.

The record sample was analyzed for total and TCLP levels of volatiles, semivolatiles, and metals, and ignitability. It was not found to exhibit a hazardous waste characteristic. A summary of the results is presented in Table 3.5.4. Only constituents detected in at least one sample are shown in this table. This residual was categorized with isomerization clay in the consent decree, and the characterization information for both residuals is presented in Table 3.5.4.

#### 3.5.2.5 Source Reduction

Treating clay for extraction is generally used as a method of prolonging the life of the catalyst or for product polishing. Because they are used as a source reduction technique for other residuals, no source reduction methods for the clays were found.



**Table 3.5.2. Treating Clay from Extraction: Physical Properties**

Properties	# of Values	# of Unreported Values <sup>1</sup>	10th %	50th %	90th %
pH	12	17	4.28	6.65	7.5
Reactive CN, ppm	14	15	0	0.5	250
Reactive S, ppm	13	16	0	1	100
Flash Point, °C	10	19	37.78	71.1	96.1
Oil and Grease, vol%	6	23	0	0.85	1
Total Organic Carbon, vol%	5	24	0	0.34	100
Specific Gravity	9	20	0.9	1	2
Aqueous Liquid, %	20	9	0	0	11
Organic Liquid, %	19	10	0	0	1
Solid, %	25	4	98	100	100
Particle >60 mm, %	10	19	0	0	100
Particle 1-60 mm, %	11	18	0	85	100
Particle 100 µm-1 mm, %	9	20	0	0	20
Particle 10-100 µm, %	8	21	0	0	20
Particle <10 µm, %	9	20	0	0	100
Median Particle Diameter, microns	1	28	10	10	10

<sup>1</sup>Facilities were not required to do additional testing, therefore information provided was based on previously collected data or engineering judgement.

**Table 3.5.3. Extraction Spent Sorbent Record Sampling Locations**

Sample number	Facility	Description
R8D-CI-01	Amoco, Texas City, TX	Clay from aromatic extraction unit (reformate feed)

**Table 3.5.4. Residual Characterization Data for Spent Treating Clay from Extraction/Isomerization**

Volatile Organics - Method 8260A µg/kg						
	CAS No.	R8D-CI-01	R23B-CI-01	Average Conc	Maximum Conc	Comments
Acetone	67641	< 600	940,000	470,300	940,000	
Benzene	71432	2,500	< 62,500	2,500	2,500	1
Isopropylbenzene	98828	J 650	< 62,500	650	650	1
Toluene	108883	36,000	< 62,500	36,000	36,000	1
Naphthalene	91203	< 600	J 29,000	14,800	29,000	
TCLP Volatile Organics - Methods 1311 and 8260A µg/L						
	CAS No.	R8D-CI-01	R23B-CI-01	Average Conc	Maximum Conc	Comments
Acetone	67641	120	32,000	16,060	32,000	
Benzene	71432	< 50	J 45	45	45	1
4-Methyl-2-pentanone	108101	< 50	6,100	3,075	6,100	
Methyl ethyl ketone	78933	< 50	3,800	1,925	3,800	
Toluene	108883	< 50	110	80	110	
1,2,4-Trimethylbenzene	95636	< 50	250	150	250	
1,3,5-Trimethylbenzene	95476	< 50	630	340	630	
m,p-Xylene	108383 / 106423	< 50	J 62	56	62	
Naphthalene	91203	< 50	J 30	30	30	1
Semivolatile Organics - Method 8270B µg/kg						
	CAS No.	R8D-CI-01	R23B-CI-01	Average Conc	Maximum Conc	Comments
Fluoranthene	206440	J 130	< 165	130	130	1
Fluorene	86737	< 165	J 220	193	220	
Isophorone	78591	< 165	130,000	65,083	130,000	
2,4-Dimethylphenol	105679	< 165	J 2,800	1,483	2,800	
3/4-Methylphenol	NA	< 165	J 150	150	150	1
Naphthalene	91203	J 280	< 165	223	280	
1-Methylnaphthalene	90120	J 220	J 650	435	650	
2-Methylnaphthalene	91576	520	J 310	415	520	
TCLP Semivolatile Organics - Methods 1311 and 8270B µg/L						
	CAS No.	R8D-CI-01	R23B-CI-01	Average Conc	Maximum Conc	Comments
Isophorone	78591	< 50	7,300	3,675	7,300	
2-Methylphenol	95487	< 50	J 34	34	34	1
3/4-Methylphenol (total)	NA	< 50	J 99	75	99	
Total Metals - Methods 6010, 7060, 7421, 7470, 7471, and 7841 mg/kg						
	CAS No.	R8D-CI-01	R23B-CI-01	Average Conc	Maximum Conc	Comments
Aluminum	7429905	8,300	110,000	59,150	110,000	
Barium	7440393	250	< 20.0	135	250	
Calcium	7440702	4,700	4,500	4,600	4,700	
Chromium	7440473	< 1.00	14.0	7.50	14.0	
Iron	7439896	1,800	3,000	2,400	3,000	
Lead	7439921	13.0	1.60	7.30	13.0	

**Table 3.5.4. Residual Characterization Data for Spent Treating Clay from Extraction/Isomerization (continued)**

Total Metals - Methods 6010, 7060, 7421, 7470, 7471, and 7841 mg/kg (continued)						
	CAS No.	R8D-CI-01	R23B-CI-01	Average Conc	Maximum Conc	Comments
Magnesium	7439954	4,300	9,600	6,950	9,600	
Manganese	7439965	350	43.0	197	350	
Potassium	7440097	< 500	1,300	900	1,300	
Sodium	7440235	< 500	81,000	40,750	81,000	
Vanadium	7440622	20.0	10.0	15.0	20.0	
Zinc	7440666	8.80	28.0	18.4	28.0	
TCLP Metals - Methods 1311, 6010, 7060, 7421, 7470, 7471, and 7841 mg/L						
	CAS No.	R8D-CI-01	R23B-CI-01	Average Conc	Maximum Conc	Comments
Aluminum	7429905	< 1.00	17.0	9.00	17.0	
Calcium	7440702	160	< 25.0	92.5	160.0	
Iron	7439896	18.0	1.30	9.65	18.0	
Lead	7439921	0.04	< 0.015	0.03	0.04	
Magnesium	7439954	82.0	50.0	66.0	82.0	
Manganese	7439965	12.0	< 0.08	6.04	12.0	

Comments:

- 1 Detection limits greater than the highest detected concentration are excluded from the calculations.

Notes:

- B Analyte also detected in the associated method blank.
- C Compound's concentration is estimated. Mass spectral data indicate the presence of a compound that meets the identification criteria for which the result is less than the laboratory detection limit, but greater than zero.
- ND Not Detected.
- NA Not Applicable.

### 3.6 ALKYLATION

The petroleum refining industry uses both hydrofluoric and sulfuric acid catalyzed alkylation processes to form high octane products. DOE reported that 103 facilities operated almost 1.1 million BPSD of alkylation capacity; 49 facilities used sulfuric acid and 59 used HF. While the general chemistry of these processes is the same, the HF process includes a closed loop and integral recycling step for the HF acid, while the sulfuric acid process requires a separate acid regeneration process, which generally occurs off site. Study residuals are generated from both alkylation processes.

#### 3.6.1 Sulfuric Acid Alkylation Process Description

In the sulfuric acid alkylation process, olefin and isobutane gases are contacted over concentrated sulfuric acid ( $H_2SO_4$ ) catalyst to synthesize alkylates for octane-boosting. The reaction products are separated by distillation and scrubbed with caustic. Alkylate product has a Research Octane Number in the range of 92 to 99. Figure 3.6.1 provides a generic process flow diagram for  $H_2SO_4$  alkylation.

Figure 1.3.1.  $H_2SO_4$  Alkylation Process Flow Diagram

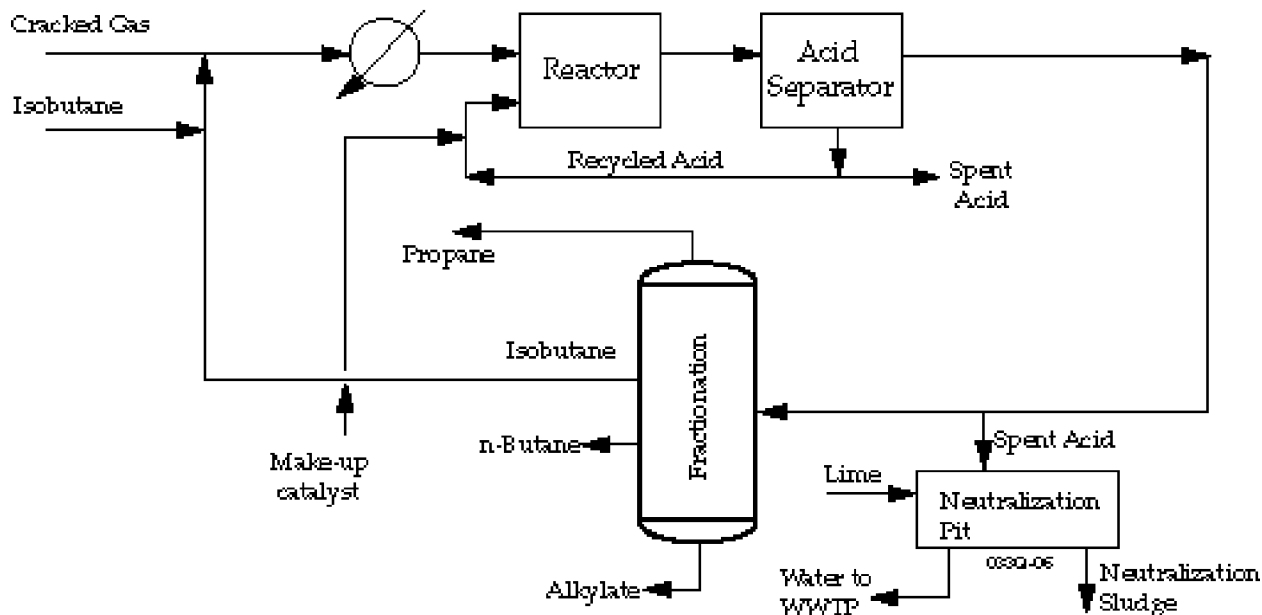

The olefin stream is mixed with isobutane and  $H_2SO_4$  in the reactor. To prevent polymerization and to obtain a higher quality yield, temperatures for the  $H_2SO_4$  catalyzed reaction are kept between 40 and 50°F (McKetta, 1992). Since the reactions are carried out below atmospheric temperatures during most of the year, refrigeration is required. Pressures are maintained so all reaction streams are in their liquid form. The streams are mixed well during their long residence time in the reactor to allow optimum reaction to occur.

The hydrocarbon/acid mixture then moves to the acid separator, where it is allowed to settle and separate. The hydrocarbons are drawn off the top and sent to a caustic wash to

neutralize any remaining trace acid. The acid is drawn from the bottom and recycled back to the reactor. A portion of the acid catalyst is continuously bled and replaced with fresh acid to maintain the reactor's acid concentration at around 90 percent. This spent  $\text{H}_2\text{SO}_4$  was a listing residual of concern.

In the fractionator, the hydrocarbon streams are separated into the alkylate and saturated gases. The isobutane is recycled back into the reactor as feed. Light end products may be filtered with sorbents to remove trace  $\text{H}_2\text{SO}_4$  acid, caustic or water. The sorbents (e.g., treating clays) are study residuals of concern.

Some facilities have neutralization tanks (in and above ground), referred to as pits, which neutralize spent caustic and any acid generated from spills prior to discharge to the WWTP, serving as surge tanks. Neutralizing agents (sodium, calcium, potassium hydroxides) are selected by the refineries. If necessary, the influent to the pit is neutralized and, depending on the neutralizing agent, the precipitated salts form a sludge. This sludge was also a listing residual of concern. Sludge may also be generated in process line junction boxes, in the spent  $\text{H}_2\text{SO}_4$  holding tank, and during turnaround. However, due to the aqueous solubility of sodium, calcium, and potassium sulfates, sludge generation rates are relatively low and the majority of neutralization salts (e.g., sodium sulfate) are solubilized and discharged to the WWTP.

### **3.6.2 Hydrofluoric Acid Alkylation Process Description**

Hydrofluoric acid alkylation is very similar to the  $\text{H}_2\text{SO}_4$  alkylation process. In the hydrofluoric acid alkylation process, olefin and isobutane gases are contacted over hydrofluoric acid (HF) catalyst to synthesize alkylates for octane-boosting. The reaction products are separated by distillation and scrubbed with caustic. Alkylate product has a research octane number (RON) in the range of 92 to 99. Because it is clean burning and contributes to reduced emissions, alkylate is a highly valued component in premium and reformulated gasolines. The HF process differs from the  $\text{H}_2\text{SO}_4$  alkylation in that the HF catalyst is managed in a closed-loop process, never leaving the unit for replacement or regeneration. Figure 3.6.2 provides a generic process flow diagram for HF alkylation.

The olefin stream is mixed with the isobutane and HF in the reactor. To prevent polymerization and to receive a higher quality yield, temperatures for the HF catalyzed reaction are maintained at approximately 100°F. Pressures are kept so all reaction streams are in their liquid form (usually 85 to 120 psi). The streams are mixed well in the reactor to allow optimum reaction to occur.

The hydrocarbon/acid mixture then moves to the settler, where it is allowed to settle and phase separate. The hydrocarbons are drawn off the top and sent to a fractionator. The acid is drawn from the bottom and recycled back to the reactor. A slip stream of acid is sent to an acid regenerator where distillation separates the HF acid from by-product contaminants. The HF acid from the regenerator is recycled back to the reactor. Fresh acid is added to replace acid losses at a rate of about 500 pounds per day per 5,000 BPSD alkylation unit capacity (a small to medium size unit).

**Figure 3.6.2. HF Alkylation Process Flow Diagram**

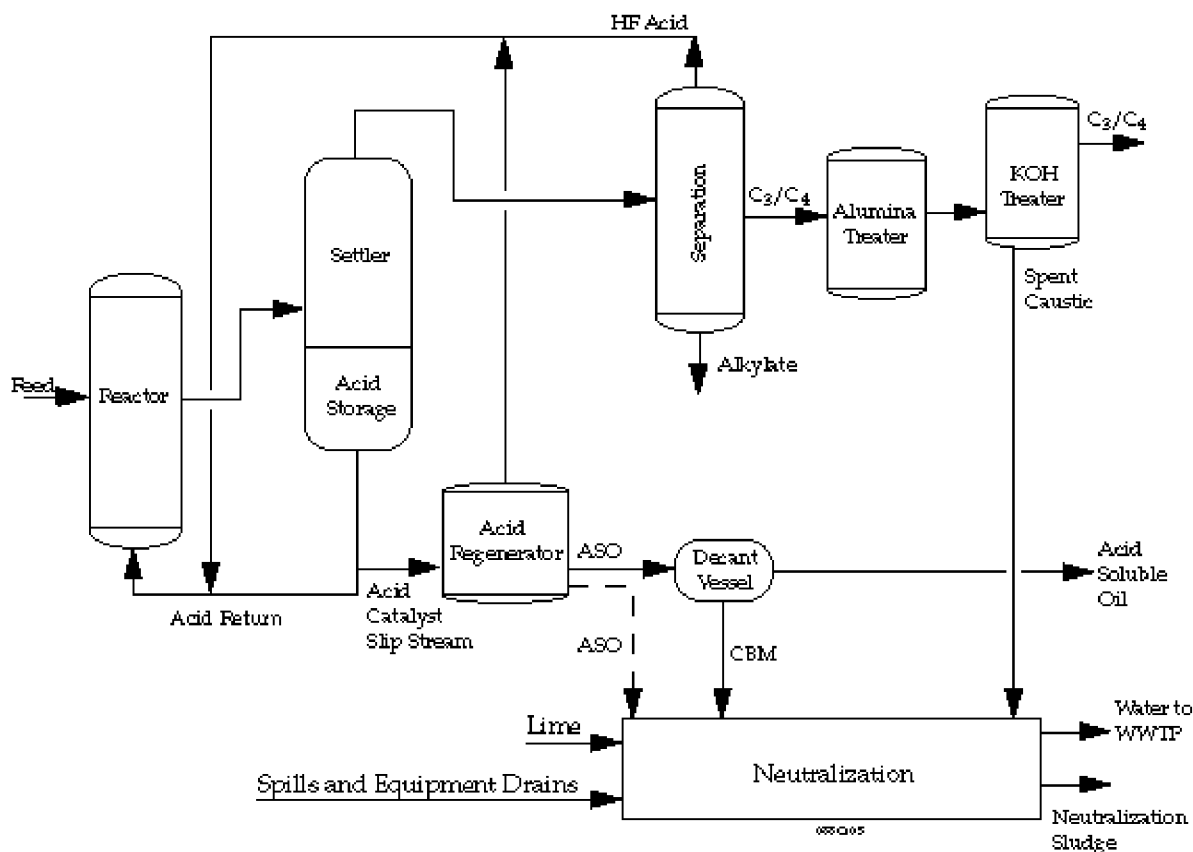

A residual of high molecular-weight reaction by-products dissolves in the HF acid catalyst and lowers its effectiveness. To maintain the catalyst activity, a slip stream of catalyst is distilled, leaving the by-product, acid soluble oil (ASO), as a residue. The ASO is charged to a decanting vessel where an aqueous phase settles out. The aqueous phase, an azeotropic mixture of HF acid and water, is referred to as constant boiling mixture (CBM). The ASO is scrubbed with potassium hydroxide (KOH) to remove trace amounts of HF and either recycled, sold as product (e.g., residual fuel), or burned in the unit's boiler. The CBM is sent to the neutralization tank. In some cases, the ASO from the regenerator is sent directly to the neutralization tank. The ASO is a residual of concern for the petroleum refining study.

A series of fractionators distills the product streams from the reactor into the alkylate, saturated gases, and HF acid. Isobutane and HF are recycled back into the reactor as feed.

The main fractionator overhead is charged to the depropanizer and debutanizer, where high-purity propane and butane are produced. The propane and butane are then passed through the alumina treater for HF removal. Once catalytically defluorinated, they are KOH-treated and sent to LPG storage.

As HF is neutralized by aqueous KOH, soluble potassium fluoride (KF) is produced and the caustic is eventually depleted. Some facilities employ KOH regeneration. Periodically some of the KF-containing neutralizing solution is withdrawn to the KOH regenerator. In this vessel

KF reacts with a lime slurry to produce insoluble calcium fluoride ( $\text{CaF}_2$ ) and thereby regenerates KF to KOH. The regenerated KOH is then returned to the system, and the solid  $\text{CaF}_2$  is routed to the neutralizing tank. The KF, at facilities that do not have a regenerator, is sent directly to the neutralizing tank, where it is reacted with lime to form a sludge.

Spent caustic, KOH scrubbers, acidic waters from acid sewers and, in some cases, CBM are charged to in-ground neutralization tanks (referred to by industry as pits), which neutralize effluent to the WWTP. Neutralizing controls fluoride levels to the WWTP. Neutralizing agents (sodium, calcium, and potassium hydroxide) are selected based on the refineries' WWTP permits. Effluent to the pit is neutralized, generally with lime, which forms a sludge (calcium fluoride) that collects on the bottom of the tank. This sludge was a listing residual of concern.

HF acid is an extremely corrosive and toxic chemical. Refineries go to great lengths to protect their personnel from HF contact. Prior to entrance to an HF alkylation unit, personnel must have special training and wear various levels of personal protective clothing (depending upon the work to be performed). The unit is generally cordoned off and marked as an HF hazard area. Valves, flanges, and any place where leaks can occur are painted with a special paint that will change colors when contacted with HF. The units are continuously monitored and alarms are activated if an HF leak is detected.

### 3.6.3 Spent Treating Clay from Alkylation

#### 3.6.3.1 Description

Treating clay from alkylation predominantly includes (1) molecular sieves used for drying feed and (2) alumina used for removing fluorinated compounds from the product. Both are applications in HF alkylation; clays are little used in sulfuric acid alkylation. Specifically, the industry reported 83 treating clay residuals from alkylation in 1992, accounting for 2,890 metric tons of residuals. Only 7 of these residuals (143 metric tons) were from sulfuric acid alkylation processes.

After fractionation, products may be passed through a filter filled with sorbents (referred to as treating clay) to remove trace amounts of acid, caustic, or water. Sorbents typically used in this service include alumina, molecular sieve, sand, and salt.

Treating clay becomes spent when breakthrough of  $\text{H}_2\text{SO}_4$  or HF acid, caustic, or water occurs. Depending on the type of clay and the type of service, breakthrough can occur anywhere between 2 months and 5 years (e.g., alumina in HF service is typically 2 months and salt treaters can be as long as 5 years). Prior to removal the clay may undergo one of the following *in situ* treatments:

- Nitrogen sweep
- Propane sweep
- Steam stripping
- Methane sweep

Following removal, the spent clay is placed in closed containers and is typically sent to an offsite landfill. Certain types of treating clay, such as alumina, are more amenable to recycling and may be sent offsite to a smelter or a cement kiln to be used as process feeds.

In 1992, less than 2 percent of the volume of spent treating clay from alkylation was managed as hazardous, with one residual reported to be D004, and three others reported generically to be managed as hazardous (i.e., no specific codes were reported).<sup>7</sup>

### 3.6.3.2 Generation and Management

The RCRA §3007 Survey responses indicated 2,895 MT of spent treating clay were generated in 1992. Residuals were assigned to be “treating clay from alkylation” if they were assigned a residual identification code of “spent sorbent” and was generated from a process identified as a sulfuric acid or HF alkylation unit. This corresponds to residual code “07” in Section VII.1 and process codes “09-A” or “09-B” in Section IV-1.C of the questionnaire. Due to the frequent generation of this residual, not all 103 facilities generated spent treating clay in 1992. However, there was no reason to expect that 1992 would not be a typical year with regard to this residual’s generation and management. Table 3.6.1 provides a description of the total quantity generated, number of streams not reporting volumes (data requested was unavailable and facilities were not required to generate it), total and average volumes.

**Table 3.6.1. Generation Statistics for Treating Clay from Alkylation, 1992**

<b>Final Management</b>	<b># of Streams</b>	<b># of Streams w/ Unreported Volume</b>	<b>Total Volume (MT)</b>	<b>Average Volume (MT)</b>
Disposal in offsite Subtitle D landfill	28	2	633.7	22.6
Disposal in offsite Subtitle C landfill	4	1	23.9	6
Disposal in onsite Subtitle C landfill	3	0	67.0	22.3
Disposal in onsite Subtitle D landfill	18	0	626.3	34.8
Disposal in onsite wastewater treatment facility	0	2	--	--
Onsite land treatment	4	0	59.2	14.8
Other recycling, or reuse: cement plant	4	0	770.5	154.1
Other recycling, or reuse: onsite road material	1	0	3.6	3.6
Storage in pile	6	0	30.0	5.0
Transfer to offsite entity: alumina manufacturer, smelter, or other unspecified recycle	15	0	680.4	45.4
<b>TOTAL</b>	<b>83</b>	<b>5</b>	<b>2,894.6</b>	<b>34.9</b>

<sup>7</sup>These percentages do not match up directly with any one of the management scenarios because the number of streams and the volume are a combination of several management scenarios (i.e., managed in WWTP, Subtitle C landfill, transfer to offsite entity, etc.).



### 3.6.3.3 Plausible Management

EPA believes that most of the plausible management practices for this residual were reported in the 1992 RCRA §3007 Survey, as summarized above in Table 3.6.1. The Agency gathered information suggesting other management practices have been used in other years including: “disposal onsite in surface impoundment” (38.4 MT), “other recycling, reclamation, or reuse: offsite fluoride recovery” (23.6 MT), and “offsite incineration” (3.6 MT). The very small volume reported to have been disposed in a surface impoundment was placed in the surface impoundment the year it was closed, suggesting the inert material was used as fill. The refinery reported the future management of the spent clay would be sent offsite to a cement kiln for reuse. Similarly, the very small volume reported for offsite fluoride recovery was a management practice seen as a trend for fluoride containing residuals during the engineering site visits. The very small volume reported for offsite incineration are comparable to the 1992 practices for other treating clay residuals (e.g., clay filtering)

### 3.6.3.4 Characterization

Two sources of residual characterization were developed during the industry study:

- Table 3.6.2 summarizes the physical properties of the alkylation sorbents as reported in Section VII.A of the §3007 survey.
- Four record samples of actual treating clay were collected and analyzed by EPA. These spent clays are all from HF processes and represent the various types of spent sorbents typically used by the industry as summarized in Table 3.6.3.

The four record samples were analyzed for total and TCLP levels of volatiles, semivolatiles, metals, fluorides, reactivity and ignitability. None of the samples were found to exhibit any of the hazardous waste characteristics. A summary of the results is presented in Table 3.6.4. Only constituents detected in at least one sample are shown in this table.

### 3.6.3.5 Source Reduction

Several solid-acid catalysts used for alkylation are being tested in pilot plants. The solid-catalyst reactor systems are different from the current liquid-acid systems, but for one solid-catalyst operation, the other process equipment is compatible. The three types of new solid catalyst include aluminum chloride, alumina/zirconium halide, and antimony pentafluoride (a slurry system). It is unclear whether these processes will generate more or less treating clays than current processes. Theoretically, these processes would not require filtering for acid and water removal.

The February 1, 1993 issue of the *Oil & Gas Journal* reported that Conoco's Ponca City, Oklahoma refinery sold reclaimed fluorinated alumina to Kaiser Aluminum & Chemical Corporation's plant in Mead, Washington. The fluorinated alumina is substituted for aluminum fluoride, a “bath” chemical used in aluminum manufacturing.

**Table 3.6.2. Treating Clay from Alkylation: Physical Properties**

Properties	# of Values	# of Unreported Values <sup>1</sup>	10th %	50th %	90th %
pH	60	91	2.91	7.00	9.00
Reactive CN, ppm	39	112	0.00	0.25	250.00
Reactive S, ppm	45	106	0.00	4.00	170.00
Flash Point, °C	43	108	60.00	93.33	100.00
Oil and Grease, vol%	43	108	0.00	0.05	1.00
Total Organic Carbon, vol%	25	126	0.00	0.00	1.00
Specific Gravity	54	97	0.70	1.24	2.24
Specific Gravity Temperature, °C	27	124	15.00	15.60	25.00
BTU Content, BTU/lb	12	139	0.00	0.00	500.00
Aqueous Liquid, %	89	62	0.00	0.00	8.00
Organic Liquid, %	85	66	0.00	0.00	1.00
Solid, %	123	28	96.00	100.00	100.00
Other, %	77	74	0.00	0.00	0.00
Particle >60 mm, %	41	110	0.00	0.00	100.00
Particle 1-60 mm, %	53	98	0.00	100.00	100.00
Particle 100 µm-1 mm, %	37	114	0.00	0.00	50.00
Particle 10-100 µm, %	38	113	0.00	0.00	3.00
Particle <10 µm, %	36	115	0.00	0.00	0.00
Median Particle Diameter, microns	21	130	0.00	1,200.00	9,525.00

<sup>1</sup>Facilities were not required to do additional testing, therefore information provided was based on previously collected data or engineering judgement.

**Table 3.6.3. Alkylation Treating Clay Record Sampling Locations**

Sample Number	Location	Description
R3-CA-01	Exxon, Billings, MT	Alumina propane product treater <sup>1</sup>
R15-CA-01	Total, Ardmore, OK	Alumina butane product treater <sup>1</sup>
R21-CA-01	Chevron, Pt. Arthur, TX	Alumina propane or butane product treater <sup>1</sup>
R23-CA-01	Chevron, Salt Lake City, UT	Alumina propane product treater <sup>1</sup>

<sup>1</sup>HF process

**Table 3.6.4. Alkylation Treating Clay Characterization**

Petroleum Refining Industry Study

80

Volatile Organics - Method 8260A µg/kg									
	CAS No.	R3-CA-01	R15-CA-01	R21-CA-01	R23-CA-01	Average Conc	Maximum Conc	Comments	
Acetone	67641	42,000	680	J 880	13,000	14,140	42,000		
Benzene	71432	J 67	< 25	< 625	< 650	46	67	1	
sec-Butylbenzene	135988	< 625	< 25	J 1,200	< 650	625	1,200		
p-Isopropyltoluene	99876	< 625	< 25	J 800	< 650	525	800		
Methyl ethyl ketone	78933	< 625	290	< 625	1,300	710	1,300		
Toluene	108883	J 67	< 25	< 625	< 650	46	67	1	
1,2,4-Trimethylbenzene	95636	J 112	< 25	2,100	< 650	722	2,100		
o-Xylene	95476	< 625	< 25	J 530	< 650	278	530	1	
m,p-Xylenes	108383/106423	J 136	< 25	1,300	< 650	528	1,300		
Naphthalene	91203	< 625	< 25	J 1,100	< 650	600	1,100		
TCLP Volatile Organics - Methods 1311 and 8260A µg/L									
	CAS No.	R3-CA-01	R15-CA-01	R21-CA-01	R23-CA-01	Average Conc	Maximum Conc	Comments	
Acetone	67641	1,500	< 50	280	B 1,100	733	1,500		
Toluene	108883	JB 11	< 50	< 50	< 50	11	11	1	
Methyl ethyl ketone	78933	J 95	< 50	210	250	151	250		
m,p-Xylene	108383 / 106423	JB 10	< 50	< 50	< 50	10	10	1	
Semivolatile Organics - Method 8270B µg/kg									
	CAS No.	R3-CA-01	R15-CA-01	R21-CA-01	R23-CA-01	Average Conc	Maximum Conc	Comments	
Di-n-butyl phthalate	84742	< 165	< 165	J 200	< 165	174	200		
Phenanthrene	85018	< 165	J 160	< 165	< 165	160	160	1	
TCLP Semivolatile Organics - Methods 1311 and 8270B µg/L									
	CAS No.	R3-CA-01	R15-CA-01	R21-CA-01	R23-CA-01	Average Conc	Maximum Conc	Comments	
Bis(2-ethylhexyl)phthalate	117817	J 10	< 50	< 50	< 50	10	10	1	
Total Metals - Methods 6010, 7060, 7421, 7470, 7471, and 7841 mg/kg									
	CAS No.	R3-CA-01	R15-CA-01	R21-CA-01	R23-CA-01	Average Conc	Maximum Conc	Comments	
Aluminum	7429905	240,000	170,000	210,000	240,000	215,000	240,000		
Arsenic	7440382	26.0	13.0	< 5.0	< 5.0	12.3	26.0		
Beryllium	7440417	2.20	1.70	2.00	2.20	2.03	2.20		
Iron	7439896	23.0	< 5.0	< 5.0	52.0	21.3	52.0		
Manganese	7439965	< 1.5	4.70	6.50	6.90	4.90	6.90		
Sodium	7440235	2,200	2,000	8,000	7,700	4,975	8,000		
Zinc	7440666	23.0	33.0	40.0	39.0	33.8	40.0		

August 1996

**Table 3.6.4. Alkylation Treating Clay Characterization (continued)**

TCLP Metals - Methods 1311, 6010, 7060, 7421, 7470, 7471, and 7841 mg/L								
	CAS No.	R3-CA-01	R15-CA-01	R21-CA-01	R23-CA-01	Average Conc	Maximum Conc	Comments
Aluminum	7429905	5,300	1,300	4,100	4,100	3,700	5,300	
Beryllium	7440417	0.05	< 0.025	< 0.025	< 0.025	0.031	0.050	
Iron	7439896	1.60	< 0.50	1.10	1.00	1.05	1.60	
Manganese	7439965	< 0.08	< 0.08	0.18	0.17	0.13	0.18	
Zinc	7440666	B 1.10	B 0.60	B 0.82	B 0.85	0.84	1.10	
Miscellaneous Characterization								
		R3-CA-01	R15-CA-01	R21-CA-01	R23-CA-01	Average Conc	Maximum Conc	Comments
Total Fluorine (mg/kg)		39,000	4,500	NA	NA	21,750	39,000	

Comments:

- 1 Detection limits greater than the highest detected concentration are excluded from the calculations.

Notes:

- B Analyte also detected in the associated method blank.
- J Compound's concentration is estimated. Mass spectral data indicate the presence of a compound that meets the identification criteria for which the result is less than the laboratory detection limit, but greater than zero.
- ND Not Detected.
- NA Not Applicable.

At the Ponca City refinery, Conoco uses activated alumina in one of the alkylation units to extract fluorides from propane and butane products. In the process, activated alumina is converted to aluminum fluoride. Activated alumina reaches the end of its useful life when 60-80% of the material is converted to aluminum fluoride. That is when it become an additive for aluminum manufacturers.

During EPA's site visits, one facility used distillation to dry its feed to the HF acid alkylation unit. Most facilities use a molecular sieve treating clay for this step, therefore this process configuration eliminates the need for molecular sieve infrequently generating an RC.

Some refineries are experimenting with additives to the HF acid catalyst. The purpose of these additives is to reduce the risk from an accidental leak of HF acid to the atmosphere. Although the technology is principally developed in reaction to safety concerns, it is likely that such additives would be present in some of the study residuals such as acid soluble oil. The identity of those additives were not reported (*Oil and Gas Journal*, August 22, 1994).

### **3.6.4 Catalyst from Hydrofluoric Acid Alkylation**

#### **3.6.4.1 Description**

The consent decree which identifies the residuals to be examined in this study specified "catalyst from HF alkylation". However, the analysis used to identify the residuals of concern in the consent decree contained some flaws and erroneously identified this alkylation catalyst as being generated in significant quantities. Upon further review of the data used to characterize this residual (derived from EPA's 1983 survey of the petroleum refining industry), it was determined that several large volume residuals were inappropriately identified as spent catalyst and instead should have been classified as acid soluble oil (ASO). After adjusting the data to remove these mischaracterized residuals, the remaining residuals classified as spent HF catalyst accounted for small volumes which are on the order of magnitude observed in the Agency's 1992 data.

A residual of high molecular-weight reaction by-products dissolves in the HF acid catalyst and lowers its effectiveness. To maintain catalyst activity, a slip stream of HF acid is sent to an acid regenerator where distillations separates the HF acid from by-product contaminants, called acid soluble oil. The HF acid from the regenerators is recycled back to the reactor. Fresh acid is added to replace acid losses at a rate of about 500 pounds per day depending on unit capacity.

ASO is charged to a decanting vessel where an aqueous phase settles out. The aqueous phase, an azeotropic mixture of HF acid and water, is referred to as constant boiling mixture (CBM). CBM is charged to the neutralization tank which neutralize effluent to the WWTP. The neutralization sludge was examined in the listing proposal and Background Document. The effluent from the neutralization tanks are reported to go to the WWTP. The Agency has no data suggesting that it can be handled in any other way.

As stated above, HF acid is an extremely corrosive and toxic chemical. Refineries go to great lengths to protect their personnel from coming into direct contact with HF acid.

### 3.6.4.2 Generation and Management

The refineries reported generating approximately 152 MT of HF alkylation catalyst in 1992. Residuals were assigned to be “HF alkylation catalyst” if they were assigned a residual identification code of “liquid catalyst” and was generated from a process identified as an HF acid alkylation unit. This corresponds to residual code 03-B in Section VII.2 of the questionnaire and process code 09-B in Section IV-1.C of the questionnaire. Table 3.6.5 provides a description of the quantity generated, number of streams reported, and number of unreported volumes. Catalyst from HF alkylation includes spills and removed acid from the HF alkylation process.

**Table 3.6.5. Generation Statistics for Catalyst from HF Alkylation, 1992**

Final Management	# of Streams	# of Streams w/ Unreported Volume	Total Volume (MT)	Average Volume (MT)
Discharge to WWTP	3	0	151.94	50.65

### 3.6.4.3 Plausible Management

EPA believes that most of the plausible management practices for this residual were reported in the 1992 RCRA §3007 Survey, as summarized above in Table 3.6.5. No data were available to the Agency suggesting any other management practices.

### 3.6.4.4 Characterization

Only one source of residual characterization is available from the industry study, reflecting the fact that this residual is not generated for management:

- Table 3.6.6 summarizes the physical properties of the HF catalyst as reported in Section VII.A of the §3007 survey.

Due to the rareness of the generation of this residual, no samples of this residual were available for collection and analysis during record sampling.

**Table 3.6.6. Catalyst from HF Alkylation: Physical Properties**

Properties	# of Values	# of Unreported Values	10th %	50th %	90th %
pH	2	1	2.00	2.00	2.00
Vapor Pressure, mm Hg	1	2	775.00	775.00	775.00
Specific Gravity	1	2	1.00	1.00	1.00
Aqueous Liquid, %	2	1	0.00	0.00	0.00
Organic Liquid, %	2	1	0.00	0.00	0.00
Solid, %	2	1	0.00	0.00	0.00
Other, %	2	1	100.00	100.00	100.00

#### 3.6.4.5 Source Reduction

As described in the spent treating clay alkylation in Section 3.6.3.5, several solid-acid catalysts used for alkylation are being tested in pilot plants. The reactor systems are different from the current liquid-acid systems, but for one system the other equipment is compatible. Three types of the new solid catalyst include aluminum chloride, alumina/zirconium halide, and antimony pentafluoride (a slurry system).

In general, additional source reduction is not possible because of the closed loop recycle process and the strict controls placed on this material due to the severe health hazards associated with contact and inhalation.

### **3.6.5 Acid Soluble Oil from Hydrofluoric Acid Alkylation**

#### 3.6.5.1 Description

A residual of high molecular-weight reaction by-products dissolves in the HF acid catalyst and lowers its effectiveness. To maintain the catalyst activity, a slip stream of catalyst is distilled, leaving the by-product, acid soluble oil (ASO), as a residue. The ASO is charged to a decanting vessel where an aqueous phase settles out. The ASO is scrubbed with potassium hydroxide (KOH) to remove trace amounts of HF and is either recycled, sold as product (e.g., residual fuel), or burned in the unit's boiler. In some cases, the ASO from the regenerator is sent directly to the neutralization tanks. Effluent from the neutralization tanks is sent to the WWTP. Neutralization tank sludges were examined under the listing proposal and Background Document.

ASO is generated exclusively from the HF process. The sulfuric acid alkylation process does not generate ASO.

Eight residuals of ASO, accounting for 25 percent of this category's volume, was reported as being managed as either D001, D002, or D008.<sup>8</sup>

#### 3.6.5.2 Generation and Management

The refineries reported generating approximately 33,493 MT of ASO in 1992. Residuals were assigned to be "ASO" if they were assigned a residual identification code of "alkylation acid regeneration tars" and were generated from a process identified as an HF acid alkylation unit. This corresponds to residual code 08 in Section VII.1 and process code 09-B in Section IV-1.C of the questionnaire. Note that sludges generated from neutralization of acid soluble oil were examined under the proposal and the Background Document and are not included here. Table 3.6.7 provides a description of the quantity generated, number of streams reported, and number of unreported volumes.

---

<sup>8</sup>These percentages do not match up directly with any one of the management scenarios because the number of streams and the volume are a combination of several management scenarios (i.e., managed in WWTP, transfer as a fuel, offsite incineration, etc.).

**Table 3.6.7. Generation Statistics for Acid Soluble Oil, 1992**

Final Management	# of Streams	# of Streams w/ Unreported Volume	Total Volume (MT)	Average Volume (MT)
Discharge to onsite wastewater treatment facility	6	0	4,858.8	809.8
Neutralization	15	14	11,387.9	759.2
Offsite incineration	2	0	0.2	0.1
Onsite boiler	3	0	2,610.3	870.1
Onsite industrial furnace	10	1	3,274	327.4
Other recovery onsite: alkylation or hydrotreating/hydrorefining process or unknown	3	1	2,180	726.7
Recovery onsite in a catalytic coker	5	0	3,641.3	728.3
Recovery onsite in a coker	1	0	1,019	1,019
Recovery onsite via distillation	2	3	50	25
Transfer for direct use as a fuel or to make a fuel	2	0	740.6	370.3
Transfer with coke product or other refinery product	4	1	3,731	932.8
<b>TOTAL</b>	<b>53</b>	<b>20</b>	<b>33,493</b>	<b>631.9</b>

### 3.6.5.3 Plausible Management

EPA believes that most of the plausible management practices for this residual were reported in the 1992 RCRA §3007 Survey, as summarized in Table 3.6.7. The Agency gathered information suggesting that “disposal in industrial Subtitle D landfill” (1 MT) was used in other years. Upon closer examination of this residual, EPA determined that the facility neutralized its ASO and landfilled the sludge. This management practice is consistent with the practices reported above.

### 3.6.5.4 Characterization

Two sources of residual characterization were developed during the industry study:

- Table 3.6.8 summarizes the physical properties of the ASO as reported in Section VII.A of the §3007 survey.
- Four record samples of actual ASO were collected and analyzed by EPA. The ASO represent the various types of interim management practices typically used by the industry (i.e., with and without neutralization) and are summarized in Table 3.6.9.

The four record samples were analyzed for total and TCLP levels of volatiles, semivolatiles, and metals, as well as ignitability. Three of the samples were found to exhibit the hazardous waste characteristic of ignitability. A summary of the results is presented in Table 3.6.10. Only constituents detected in at least one sample are shown in this table.



**Table 3.6.8. Acid Soluble Oil: Physical Properties**

Properties	# of Values	# of Unreported Values <sup>1</sup>	10th %	50th %	90th %
pH	30	59	2.00	6.50	10.75
Reactive CN, ppm	12	77	0.00	0.13	50.00
Reactive S, ppm	14	75	0.00	5.00	200.00
Flash Point, °C	27	62	25.00	60.00	93.33
Oil and Grease, vol%	26	63	15.00	90.00	100.00
Total Organic Carbon, vol%	16	73	30.00	77.00	100.00
Vapor Pressure, mm Hg	10	79	3.00	135.00	575.00
Vapor Pressure Temperature, °C	9	80	20.00	25.00	38.00
Viscosity, lb/ft-sec	11	78	0.00	0.01	0.40
Viscosity Temperature, °C	6	83	15.00	17.50	37.80
Specific Gravity	34	55	0.80	0.90	1.00
Specific Gravity Temperature, °C	12	77	15.00	15.00	15.60
BTU Content, BTU/lb	15	74	750.00	15,000.00	19,000.00
Aqueous Liquid, %	47	42	0.00	10.00	75.00
Organic Liquid, %	56	33	50.00	98.00	100.00
Solid, %	32	57	0.00	0.00	30.00
Other, %	27	62	0.00	0.00	0.05

<sup>1</sup>Facilities were not required to do additional testing, therefore information provided was based on previously collected data or engineering judgment.

**Table 3.6.9. Acid Soluble Oil Record Sampling Locations**

Sample Number	Location	Description
R3-AS-01	Exxon, Billings, MT	Un-neutralized separator drum sample
R5B-AS-01	Marathon, Garyville, LA	Acid regenerator settler bottoms, not neutralized
R15-AS-01	Total, Ardmore, OK	Neutralized, skimmed from pit
R7C-AS-01	BP, Belle Chasse, LA	Neutralized from storage tank

### 3.6.5.5 Source Reduction

As described in previous sections, several solid-acid catalysts used for alkylation are being tested in pilot plants. The reactor systems are different from the current liquid-acid systems, but for one system the other equipment is compatible. Three types of the new solid catalyst include aluminum chloride, alumina/zirconium halide, and antimony pentafluoride (a slurry system).

It is likely that ASO will not be generated in a solid catalyst system.

**Table 3.6.10. Acid Soluble Oil Characterization**

Petroleum Refining Industry Study

87

Volatile Organics - Method 8260A µg/L					(µg/kg)		Average Conc	Maximum Conc	Comments
CAS No.	R3-AS-01	R5B-AS-01	R7C-AS-01	R15-AS-01					
Acetone	67641	49,000	< 625	B 40,000	3,000	23,156	49,000		
Acrolein	107028	< 6250	< 625	25,000	< 1,250	8,281	25,000		
Benzene	71432	< 6250	< 625	30,000	< 1,250	9,531	30,000		
n-Butylbenzene	104518	< 6250	< 625	J 9,500	< 1,250	4,406	9,500		
sec-Butylbenzene	135988	< 6250	< 625	J 2,600	J 488	1,238	2,600	1	
tert-Butylbenzene	98066	< 6250	< 625	J 7,200	J 1,350	3,856	7,200		
Carbon disulfide	75150	< 6250	< 625	J 1,800	< 1,250	1,225	1,800	1	
trans-1,3-Dichloropropene	10061026	< 6250	< 625	J 1,600	< 1,250	1,158	1,600	1	
Ethylbenzene	100414	< 6250	< 625	37,000	< 1,250	11,281	37,000		
Isopropylbenzene	98828	< 6250	< 625	J 3,100	< 1,250	1,658	3,100	1	
p-Isopropyltoluene	99876	< 6250	< 625	J 6,600	< 1,250	3,681	6,600		
Methyl ethyl ketone	78933	< 6250	< 625	27,000	< 1,250	8,781	27,000		
4-Methyl-2-pentanone	108101	< 6250	< 625	26,000	< 1,250	8,531	26,000		
n-Propylbenzene	103651	< 6250	< 625	J 8,200	< 1,250	4,081	8,200		
Toluene	108883	< 6250	< 625	41,000	< 1,250	12,281	41,000		
1,2,4-Trimethylbenzene	95636	18,000	7,400	110,000	3,300	34,675	110,000		
1,3,5-Trimethylbenzene	108678	< 6250	< 625	27,000	J 1,260	8,784	27,000		
o-Xylene	95476	< 6250	< 625	20,000	< 1,250	7,031	20,000		
m,p-Xylenes	108383 / 106423	16,000	2,100	55,000	< 1,250	18,588	55,000		
Naphthalene	91203	< 6250	< 625	30,000	< 1,250	9,531	30,000		
TCLP Volatile Organics - Methods 1311 and 8260A µg/L									
CAS No.	R3-AS-01	R5B-AS-01	R7C-AS-01	R15-AS-01	Average Conc	Maximum Conc	Comments		
Acetone	67641	NA	NA	NA	B 350	350	350		
Isopropylbenzene	98828	NA	NA	NA	J 32	32	32		
Methyl ethyl ketone	78933	NA	NA	NA	J 80	80	80		
Semivolatile Organics - Method 8270B µg/L					(µg/kg)		Average Conc	Maximum Conc	Comments
CAS No	R3-AS-01	R5B-AS-01	R7C-AS-01	R15-AS-01					
Methyl ethyl ketone	78933	NA	NA	NA	J 80	80	80		
1-Methylnaphthalene	90120	< 250,000	< 46,000	100,000	< 12,375	73,000	100,000	1	
2-Methylnaphthalene	91576	< 250,000	< 46,000	180,000	< 12,375	113,000	180,000	1	
Naphthalene	91203	< 250,000	< 46,000	79,000	< 12,375	62,500	79,000	1	
2-Methylnaphthalene	91576	< 250,000	< 46,000	180,000	< 12,375	113,000	180,000	1	
Naphthalene	91203	< 250,000	< 46,000	79,000	< 12,375	62,500	79,000	1	

August 1996

**Table 3.6.10. Acid Soluble Oil Characterization (continued)**

TCLP Semivolatile Organics - Methods 1311 and 8270B µg/L								
	CAS No.	R3-AS-01	R5B-AS-01	R7C-AS-01	R15-AS-01	Average Conc	Maximum Conc	Comments
Aniline	62553	NA	NA	NA	J 20	20	20	
Total Metals - Methods 6010, 7060, 7421, 7470, 7471, and 7841 mg/kg						(mg/kg)		
	CAS No.	R3-AS-01	R5B-AS-01	R7C-AS-01	R15-AS-01	Average Conc	Maximum Conc	Comments
Aluminum	7429905	< 0.10	< 0.10	< 0.10	290	NA	NA	
Calcium	7440702	< 2.50	< 2.50	< 2.50	29,000	NA	NA	
Copper	7440508	1.00	< 0.13	< 0.13	37.0	0.42	1.00	
Iron	7439896	< 0.50	< 0.50	< 0.50	120	NA	NA	
Lead	7439921	0.64	< 0.015	< 0.015	< 0.30	0.22	0.64	
Manganese	7439965	< 0.015	< 0.015	< 0.015	5.00	NA	NA	
Mercury	7439976	< 0.01	0.022	< 0.01	< 0.05	0.014	0.022	
Nickel	7440020	< 0.04	< 0.04	< 0.04	15.0	NA	NA	
Potassium	7440097	< 2.50	< 2.50	< 2.50	5,900	NA	NA	
Sodium	7440235	< 2.50	< 2.50	< 2.50	1,300	NA	NA	
Zinc	7440666	0.27	< 0.10	< 0.10	< 2.00	0.16	0.27	
TCLP Metals - Methods 1311, 6010, 7060, 7421, 7470, 7471, and 7841 mg/L								
	CAS No.	R3-AS-01	R5B-AS-01	R7C-AS-01	R15-AS-01	Average Conc	Maximum Conc	Comments
Potassium	7440097	NA	NA	NA	140	140	140	
Zinc	7440666	NA	NA	NA	B 0.24	0.24	0.24	
Miscellaneous Characterization								
		R3-AS-01	R5B-AS-01	R7C-AS-01	R15-AS-01	Average Conc	Maximum Conc	Comments
Total Fluorine (mg/L)		450	110	19.0	9,300 mg/kg	193	450	
Ignitability (oF)		132	57	97	> 158	NA	NA	
Corrosivity (pH)		3	5	7	10.8	NA	NA	
Heat of Combustion ( BTU/lb )		18,700	19,245	19,000	14,000	17,736	19,245	

Comments:

- 1 Detection limits greater than the highest detected concentration are excluded from the calculations.

Notes:

- B Analyte also detected in the associated method blank.
- J Compound's concentration is estimated. Mass spectral data indicate the presence of a compound that meets the identification criteria for which the result is less than the laboratory detection limit, but greater than zero.
- ND Not Detected.
- NA Not Applicable.

## 3.7 POLYMERIZATION

Polymerization is a process utilized for the conversion of propane/propylene and/or butane/butene feeds from other operations into a low molecular weight, higher-octane, polymer product, referred to as dimate. Dimate is used as a high octane gasoline blending component of unleaded gasolines.

Almost 12 percent of the industry's polymerization catalyst (Dimersol and phosphoric acid) volume was reported to be managed as a hazardous waste ("as hazardous", D002 and D007).<sup>9</sup>

### 3.7.1 Process Descriptions

There are primarily two polymerization processes utilized by the petroleum refining industry: phosphoric acid polymerization and the Dimersol process, licensed by IFP (Institute Francais du Petrole, or the French Petroleum Institute). Process descriptions for each of these two processes are provided in the following sections.

#### 3.7.1.1 Phosphoric Acid Polymerization

Phosphoric acid polymerization units produce marginal octane gasoline from propylene feeds from other operating units (i.e., the FCC unit, coking, etc). Phosphoric acid polymerization is more widely used by industry than the Dimersol process, representing 80 percent of all polymerization units in the United States. Phosphoric acid polymerization unit capacities range from 400 to 8,000 barrels per stream day, with the majority of units ranging between 2,200 and 3,000 barrels per stream day (as reported in the §3007 survey).

Phosphoric acid polymerization utilizes a catalyst consisting of an alumina substrate impregnated with phosphoric acid. A typical phosphoric acid polymerization unit contains one or more reactors consisting of a series of tubes coming off of a single header. The reactor feed is charged to the header and flows through the tubes. The tubes are packed with the phosphoric acid catalyst. The reaction conditions are controlled to stop the polymerization at the desired C6 or C9 product. The polymerization reaction is highly exothermic and boiler feed water is fed through the reactor (on the shell side of the tubes) to recover the heat for use as steam. Over time, the catalyst's acid sites become blocked and the catalyst is slated for change-out.

After leaving the reactor, the reactor effluent is fractionated to give the desired products. A simplified process flow diagram for a typical phosphoric acid polymerization unit is shown in Figure 3.7.1.

---

<sup>9</sup>These percentages do not match up directly with any one of the management scenarios because the number of streams and the volume are a combination of several management scenarios (i.e., Subtitle C landfill, recovery in coker, etc.).

**Figure 3.7.1. Process Flow Diagram for Phosphoric Acid Polymerization Process**

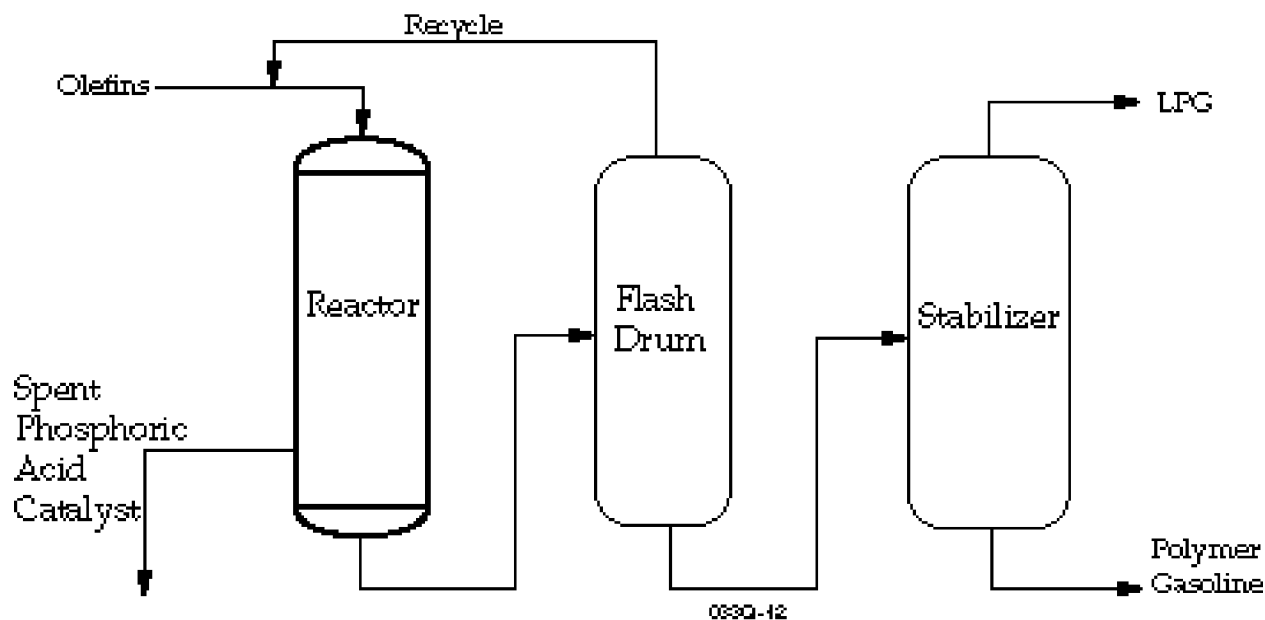

### 3.7.1.2 Dimersol Polymerization

As stated above, Dimersol polymerization units represent only 20 percent of the existing polymerization units in the United States. The capacity of Dimersol units range from 1,000 to 5,500 barrels per stream day, with an average capacity of approximately 3,200 barrels per stream day (as reported in the §3007 survey).

The Dimersol process is used to dimerize light olefins such as ethylene, propylene and butylene. The process typically begins with the pretreatment of the propane/propylene or butane/butene feed prior to entering the reactor section of the process. Pretreatment can include the use of molecular sieve dryers, sand filters, etc. to remove water and/or H<sub>2</sub>S. Water in the feed stream can deactivate the catalysts used in the Dimersol process. After drying the feed is combined with a liquid nickel carboxylate/ethyl aluminum dichloride (EADC) catalyst prior to entering the first of a series of three reactors. The first two are continuous stirred batch reactors and the third is a plug-flow tubular reactor. The reactor feed is converted to the process product, dimate, primarily in the first reactor, and additional conversion is achieved in the last two reactors. The final reactor effluent consists of dimate product, unreacted C<sub>3</sub>/C<sub>4</sub>s, and liquid catalyst. Immediately following the last reactor, the liquid catalyst is removed from the reactor effluent by treating the reactor effluent with caustic, subsequent water washing, and filtering to remove solids. Spent caustic residuals are typically reused or reclaimed on- or off-site, and as a result, do not constitute solid wastes. After filtering, the product stream enters a “Dimersol stabilizer,” a distillation unit that removes unreacted LPG from the dimate product. In some cases, the product stream is also further treated by drying. LPG from the stabilizer overhead is typically sent to another unit of the refinery for further processing. The dimate product from the bottom of the stabilizer is sent to storage or product blending.

A simplified process flow diagram for a typical Dimersol polymerization unit is shown in Figure 3.7.2.

**Figure 3.7.2. Dimersol Polymerization Process Flow Diagram**

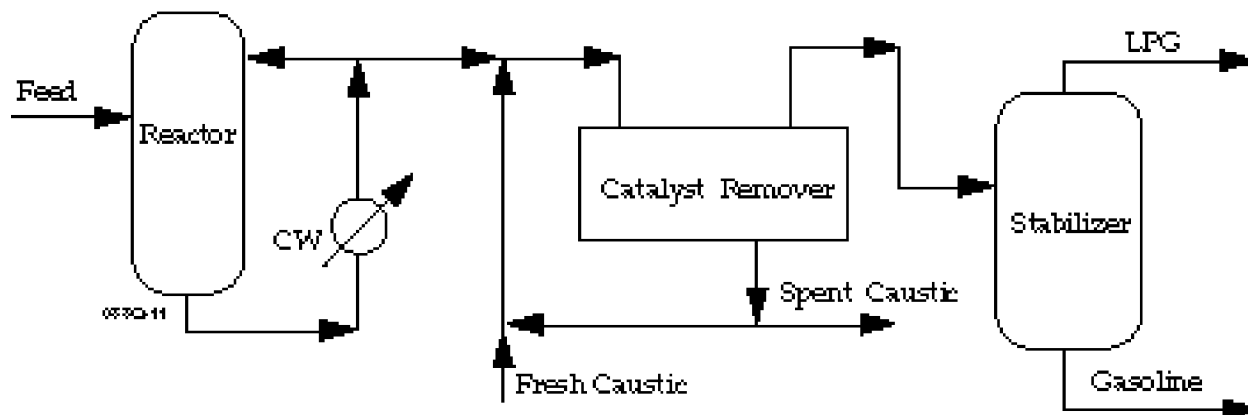

### 3.7.2 Spent Phosphoric Acid Polymerization Catalyst

#### 3.7.2.1 Description

Spent phosphoric acid polymerization catalyst is generated after the solid catalyst active sites have become blocked and lost their reactivity.

#### 3.7.2.2 Generation and Management

During reactor change-outs, spent phosphoric acid catalysts are flushed or water drilled from the shell-and-tube reactors.

Twenty-two facilities reported generating a total quantity of 3,358 MT of this residual in 1992, according to the 1992 RCRA §3007 Questionnaire. Residuals were assigned to be “spent phosphoric acid polymerization catalyst” if they were assigned a residual identification code of “spent solid catalyst” or “spent catalyst fines” and were generated from a process identified as a phosphoric acid polymerization unit. These correspond to residual codes 03-A and 03-B in Section VII.2 of the questionnaire and process code 11-A in Section IV-1.C of the questionnaire. Quality assurance was conducted by ensuring that all phosphoric acid polymerization catalysts previously identified in the questionnaire (i.e., in Section V.B) were assigned in Section VII.2.

Based on the results of the questionnaire, 25 facilities use phosphoric acid polymerization units and are thus likely to generate spent phosphoric acid polymerization catalyst. Due to the infrequent generation of this residual, not all of these 25 facilities generated spent catalyst in 1992. However, there was no reason to expect that 1992 would not be a typical year with regard to this residual's generation and management. Table 3.7.1 provides a description of the quantity generated, number of streams reported, number of streams not reporting volumes (data requested was unavailable and facilities were not required to generate it), total and average volumes.

**Table 3.7.1. Generation Statistics for Phosphoric Acid Catalyst from Polymerization, 1992**

<b>Final Management</b>	<b># of Streams</b>	<b># of Streams w/ Unreported Volume</b>	<b>Total Volume (MT)</b>	<b>Average Volume (MT)</b>
Disposal in offsite Subtitle D landfill	12	0	1,429.5	119
Disposal in offsite Subtitle C landfill	3	0	62	20.7
Disposal in onsite Subtitle C landfill	2	0	349	174.5
Disposal in onsite Subtitle D landfill	6	0	246.8	41
Onsite land treatment	3	0	728	242.7
Transfer for use as an ingredient in products placed on the land	7	0	542.5	77.5
<b>TOTAL</b>	<b>33</b>	<b>0</b>	<b>3357.8</b>	<b>101.7</b>

3.7.2.3 Plausible Management

EPA believes that most of the plausible management practices for this residual were reported in the 1992 RCRA §3007 Survey, as summarized above in Table 3.7.1. No data were available to the Agency suggesting any other management practices.

3.7.2.4 Characterization

Two sources of residual characterization were developed during the industry study:

- Table 3.7.2 summarizes the physical properties of the spent catalyst as reported in Section VII.A of the §3007 survey.
- One record sample of phosphoric acid polymerization catalyst was collected and analyzed by EPA. The sample is representative of typical phosphoric acid polymerization catalyst used by the industry and is summarized in Table 3.7.3.

The record sample was analyzed for total and TCLP levels of volatiles, semivolatiles, and metals, reactivity (pyrophoricity) and corrosivity. The sample was found to exhibit the hazardous waste characteristic of corrosivity. Dimersol and phosphoric acid catalysts were categorized together in the consent decree, therefore, a summary of the results for both residuals is presented in Table 3.7.7. Only constituents detected in at least one sample are shown in this table.

**Table 3.7.2. Phosphoric Acid Catalyst from Polymerization: Physical Properties**

Properties	# of Values	# of Unreported Values <sup>1</sup>	10th %	50th %	90th %
pH	21	21	1.4	4.7	7
Reactive CN, ppm	12	30	0.01	7	40
Reactive S, ppm	12	30	1	10	40
Flash Point, °C	14	28	60	93.3	200
Oil and Grease, vol%	16	26	0	0	25.5
Total Organic Carbon, vol%	15	27	0	0	16.6
Specific Gravity	20	22	0.85	0.96	1.4
Aqueous Liquid, %	29	13	0	0	50
Organic Liquid, %	28	14	0	0	1
Solid, %	35	7	50	100	100
Particle >60 mm, %	16	26	0	0	0
Particle 1-60 mm, %	17	25	0	95	95
Particle 100 µm-1 mm, %	16	26	0	5	5
Particle 10-100 µm, %	16	26	0	0	100
Particle <10 µm, %	16	26	0	0	0
Median Particle Diameter, microns	10	31	5030	12,000	12,000

<sup>1</sup>Facilities were not required to do additional testing, therefore information provided was based on previously collected data or engineering judgment.

**Table 3.7.3. Phosphoric Acid Polymerization Catalyst Record Sampling Locations**

Sample Number	Location	Description
R16-PC-01	Koch, St. Paul, MN	Phosphoric acid catalyst

### 3.7.2.5 Source Reduction

No source reduction techniques were reported by industry or found in the literature search for this residual.



### 3.7.3 Spent Dimersol Polymerization Catalyst

#### 3.7.3.1 Description

Dimersol catalyst is added to the reactor feed stream and exits the final reactor as part of the reactor effluent. The liquid catalyst is then removed from the reactor effluent by neutralization (contact with caustic). Spent caustic streams, containing the spent dimersol catalyst, are commonly reused on-site or sent off-site for metals reclamation or caustic recovery, and as a result are typically not solid wastes. Spent catalyst also may be generated in two other points in the process. First, during routine shutdowns spent catalyst may be generated as a component of any reactor sludge removed from the reactors. Second, certain Dimersol processes contain filters following caustic neutralization and water washing to remove entrained residual nickel from the dimate product. The filters are removed and disposed periodically.

#### 3.7.3.2 Generation and Management

Dimersol catalysts are generated as solid wastes in the form of reactor sludges generated during reactor clean-outs and as spent nickel filters.

Four facilities reported generating a total quantity of 761.5 MT of this residual as a reactor sludge in 1992, according to the 1992 RCRA §3007 Survey. Residuals were assigned to be “spent dimersol catalyst” if they were assigned a residual identification code of “spent solid catalyst” or “spent catalyst fines” or “other process sludge” and were generated from a process identified as a Dimersol polymerization unit. These correspond to residual codes “03-A,” “03-B” and “02-D” in Section VII.2 and process code “11-B” in Section IV-1.C of the questionnaire. Quality assurance was conducted by ensuring that all dimersol catalysts previously identified in the questionnaire (i.e., in Section V.B) were assigned in Section VII.2.

Based on the results of the survey, 7 facilities use Dimersol polymerization units and may generate spent dimersol catalyst. Due to the continuous generation of this residual, 1992 is expected to be a typical year in regard to catalyst generation volume and management. There was no reason to expect that 1992 would not be a typical year with regard to this residual's generation and management. Table 3.7.4 provides a description of the quantity generated, number of streams reported, number of streams not reporting volumes (data requested was unavailable and facilities were not required to generate it), total and average volumes.

#### 3.7.3.3 Plausible Management

EPA believes that most of the plausible management practices for this residual were reported in the 1992 RCRA §3007 Survey, as summarized above in Table 3.7.4. No data were available to the Agency suggesting any other management practices. Unlike with phosphoric acid polymerization catalyst, EPA does not expect spent Dimersol catalyst to be land treated due to the physical nature of the filters.

**Table 3.7.4. Generation Statistics for Spent Dimersol Polymerization Catalyst, 1992**

<b>Final Management</b>	<b># of Streams</b>	<b># of Streams w/ Unreported Volume</b>	<b>Total Volume (MT)</b>	<b>Average Volume (MT)</b>
Disposal Offsite Subtitle C Landfill	1	0	3.4	3.4
Disposal Onsite Subtitle D Landfill	1	0	8.8	8.8
Offsite incineration	1	1	0.3	0.3
Recover onsite in a coker	1	0	749	749
<b>TOTAL</b>	<b>4</b>	<b>1</b>	<b>761.5</b>	<b>190.4</b>

#### 3.7.3.4 Characterization

Two sources of residual characterization were developed during the industry study:

- Table 3.7.5 summarizes the physical properties of the spent catalyst as reported in Section VII.A of the §3007 survey.
- Two record samples of Dimersol polymerization catalyst were collected and analyzed by EPA. The samples represent typical Dimersol polymerization catalyst used by the industry and are summarized in Table 3.7.6.

The two record samples were analyzed for total and TCLP levels of volatiles, semivolatiles, and metals, and pyrophoricity and corrosivity. None of the samples were found to exhibit a hazardous waste characteristic. Dimersol and phosphoric acid catalysts were categorized together in the consent decree, therefore, a summary of the results for both residuals is presented in Table 3.7.7. Only constituents detected in at least one sample are shown in this table.

#### 3.7.3.5 Source Reduction

No source reduction techniques were reported by industry or found in the literature search for this residual.

**Table 3.7.5. Spent Dimersol Polymerization Catalyst Physical Properties**

Properties	# of Values	# of Unreported Values <sup>1</sup>	10th %	Mean	90th %
pH	7	4	3.8	5.5	9
Flash Point, C	4	7	93.3	93.3	100
Oil and Grease, vol%	3	8	2.6	5.3	6.4
Total Organic Carbon, vol%	3	8	0.08	4.1	9.5
Specific Gravity	6	5	0.7	1.2	1.4
Aqueous Liquid, %	11	0	0	0	70
Organic Liquid, %	11	0	0	0	60
Solid, %	11	0	20	100	100

<sup>1</sup>Facilities were not required to do additional testing, therefore information provided was based on previously collected data or engineering judgment.

**Table 3.7.6. Dimersol Polymerization Catalyst Record Sampling Locations**

Sample Number	Location	Description
R6B-PC-01	Shell, Norco, LA	Dimersol filter
R16-PC-02	Koch, St. Paul, MN	Dimersol filter

**Table 3.7.7. Polymerization Catalyst Characterization**

Petroleum Refining Industry Study

97

Volatile Organics - Method 8260A µg/kg										
	CAS No.	R6B-PC-01		R16-PC-01		R16-PC-02		Average Conc	Maximum Conc	Comments
Ethylbenzene	100414	<	25	J	92	<	625	59	92	1
Isopropylbenzene	98828	<	25	J	350	<	625	188	350	1
Naphthalene	91203		58	<	250	<	625	58	58	1
Toluene	108883	<	25	J	130	<	625	78	130	1
1,2,4-Trimethylbenzene	95636	<	25	J	91	<	625	58	91	1
1,3,5-Trimethylbenzene	108678	<	25	J	91	<	625	58	91	1
m,p-Xylenes	108383 / 106423	<	25	J	120	<	625	73	120	1
TCLP Volatile Organics - Methods 1311 and 8260A µg/L										
	CAS No.	R6B-PC-01		R16-PC-01		R16-PC-02		Average Conc	Maximum Conc	Comments
None Detected	NA		NA		NA		NA		NA	
Semivolatile Organics - Method 8270B µg/kg										
	CAS No.	R6B-PC-01		R16-PC-01		R16-PC-02		Average Conc	Maximum Conc	Comments
Acenaphthene	83329	<	2,063	J	360	<	165	263	360	1
Anthracene	120127	<	2,063	J	300	<	165	233	300	1
Benz(a)anthracene	56553	<	2,063		990	<	165	578	990	1
Bis(2-ethylhexyl) phthalate	117817	<	2,063	<	413		630	521	630	1
Di-n-butyl phthalate	84742	<	2,063	<	413	J	77	77	77	1
Chrysene	218019	<	2,063		890	<	165	528	890	1
Dibenzofuran	132649	<	2,063	J	420	<	165	293	420	1
Fluoranthene	206440	<	2,063	J	210	<	165	188	210	1
Fluorene	86737	<	2,063		1,300	<	165	733	1,300	1
2-Methylchrysene	3351324	<	4,125	J	570	<	330	450	570	1
1-Methylnaphthalene	90120	<	4,125		1,800	<	330	1,065	1,800	1
2-Methylnaphthalene	91576	<	2,063		1,700	<	165	933	1,700	1
Phenanthrene	85018	<	2,063		3,100	<	165	1,776	3,100	1
Pyrene	129000	<	2,063		3,400	<	165	1,876	3,400	1
TCLP Semivolatile Organics - Methods 1311 and 8270B µg/L										
	CAS No.	R6B-PC-01		R16-PC-01		R16-PC-02		Average Conc	Maximum Conc	Comments
None Detected	NA		NA		NA		NA		NA	

August 1996

**Table 3.7.7. Polymerization Catalyst Characterization (continued)**

Total Metals - Methods 6010, 7060, 7421, 7470, 7471, and 7841 mg/kg							
	CAS No.	R6B-PC-01	R16-PC-01	R16-PC-02	Average Conc	Maximum Conc	Comments
Aluminum	7429905	6,500	3,400	19,000	9,633	19,000	
Arsenic	7440382	210	< 1.00	5.30	72.1	210	
Barium	7440393	2,600	< 20.0	4,200	2,273	4,200	
Calcium	7440702	1,200	3,500	< 500	1,733	3,500	
Chromium	7440473	2.70	33.0	< 1.00	12.2	33.0	
Cobalt	7440484	15.0	< 5.00	< 5.00	8.33	15.0	
Copper	7440508	7.40	21.0	28.0	18.8	28.0	
Iron	7439896	1,300	4,200	500	2,000	4,200	
Lead	7439921	3.50	9.70	2.20	5.13	9.70	
Magnesium	7439954	< 500	1,200	< 500	733	1,200	
Manganese	7439965	13.0	57.0	15.0	28.3	57.0	
Mercury	7439976	0.10	< 0.05	< 0.05	0.07	0.10	
Nickel	7440020	9,600	52.0	75,000	28,217	75,000	
Potassium	7440097	1,100	< 500	< 500	700	1,100	
Sodium	7440235	13,000	< 500	8,000	7,167	13,000	
Vanadium	7440622	< 5.00	21.0	< 5.00	10.3	21.0	
Zinc	7440666	1,700	1,400	3,000	2,033	3,000	
TCLP Metals - Methods 1311, 6010, 7060, 7421, 7470, 7471, and 7841 mg/L							
	CAS No.	R6B-PC-01	R16-PC-01	R16-PC-02	Average Conc	Maximum Conc	Comments
Arsenic	7440382	0.19	NA	< 0.05	0.12	0.19	
Barium	7440393	< 1.00	NA	36.0	18.5	36.0	
Nickel	7440020	160	NA	67.0	114	160	
Zinc	7440666	B 1.40	NA	B 4.90	3.15	4.90	
Miscellaneous Characterization							
		R6B-PC-01	R16-PC-01	R16-PC-02			
Corrosivity (pH)		NA	< 1.0	NA			

Comments:

- 1 Detection limits greater than the highest detected concentration are excluded from the calculations.

Notes:

- B Analyte also detected in the associated method blank.
- J Compound's concentration is estimated. Mass spectral data indicate the presence of a compound that meets the identification criteria for which the result is less than the laboratory detection limit, but greater than zero.
- ND Not Detected.
- NA Not Applicable.

**STUDY OF SELECTED  
PETROLEUM REFINING RESIDUALS  
  
INDUSTRY STUDY**

August 1996

U.S. ENVIRONMENTAL PROTECTION AGENCY  
Office of Solid Waste  
Hazardous Waste Identification Division  
401 M Street, SW  
Washington, DC 20460

## 3.8 RESIDUAL UPGRADING

After vacuum distillation, there are still some valuable oils left in the vacuum-reduced crude. Vacuum tower distillation bottoms and other residuum feeds can be upgraded to higher value products such as higher grade asphalt or feed to catalytic cracking processes. Residual upgrading includes processes where asphalt components are separated from gas oil components by the use of a solvent. It also includes processes where the asphalt value of the residuum is upgraded (e.g., by oxidation) prior to sale. Off-spec product and fines, as well as process sludges, are study residuals from this category.

### 3.8.1 Process Descriptions

A total of 47 refineries reported using residual upgrading units. Four types of residual upgrading processes were reported in the 1992 RCRA §3007 Petroleum Refining Survey:

- Solvent Deasphalting
- Asphalt Oxidation
- Supercritical Extraction
- Asphalt Emulsion

Asphalt uses are typically divided into use as road oils, cutback asphalts, asphalt emulsions, and solid asphalts. These asphalt products are used in paving roads, roofing, paints, varnishes, insulating, rust-protective compositions, battery boxes, and compounding materials that go into rubber products, brake linings, and fuel briquettes (REF).

#### 3.8.1.1 Solvent Deasphalting

Residuum from vacuum distillation is separated into asphalt components and gas oil components by solvent deasphalting. Figure 3.8.1 provides a simplified process flow diagram. The hydrocarbon solvent is compressed and contacted with the residuum feed. The extract contains the paraffinic fractions (deasphalted oil or DAO), and the raffinate contains the asphaltic components. The extract and raffinate streams are sent to separate solvent recovery systems to reclaim the solvent. The DAO may be further refined or processed, used as catalytic cracking feed, sent to lube oil processing/blending, or sold as finished product. The following types of solvents are typically used for the following residual upgrading processes:

- Propane is the best choice for lube oil production due to its ability to extract only paraffinic hydrocarbons and to reject most of the carbon residue. (McKetta)
- A mixture of propane and butane is valuable for preparing feedstocks for catalytic cracking processes due to its ability to remove metal-bearing components. (McKetta)
- Pentane deasphalting, plus hydrodesulfurization, can produce more feed for catalytic cracking or low sulfur fuel oil. (McKetta)

**Figure 3.8.1. Solvent Deasphalting Process Flow Diagram**

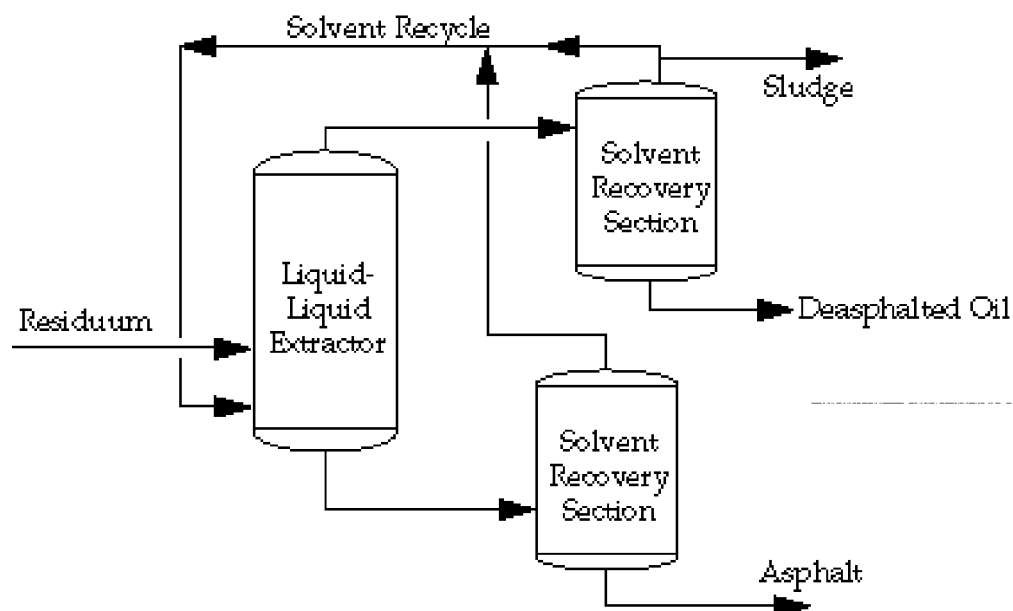

- One facility reported using propane and phenol solvents for deasphalting residuum. The DAO is sent to lube oil processing and the asphalt fraction is sent to delayed coking or fuel oil blending.

During process upsets, heavy hydrocarbons may become entrained in the solvent recovery systems, and off-specification product may be generated. The entrained hydrocarbons are periodically removed from the unit as a process sludge and typically disposed in an industrial landfill. The off-specification product are returned to the process for re-processing.

### 3.8.1.2 Asphalt Oxidation (Asphalt Blowing)

Residuum from the vacuum tower or from solvent deasphalting is upgraded by oxidation with air. Figure 3.8.2 provides a simplified process flow diagram. Air is blown through the asphalt that is heated to about 500°F, starting an exothermic reaction. The temperature is controlled by regulating the amount of air and by circulating oil or water through cooling coils within the oxidizer. The oxygen in the air reacts with hydrogen in the residuum to form water, and the reaction also couples smaller molecules of asphalt into larger molecules to create a heavier product. These reactions changes the characteristics of the asphalt to a product with the desired properties.

During this process, coke will form on the oxidizer walls and the air sparger. The coke is removed periodically (1 to 2 years) and sent to the coke pad for sale, mixed with asphalt for use as road material, stored, or disposed. The off-gases from the process are scrubbed to remove hydrocarbons prior to burning in an thermal unit such as an incinerator or furnace.



**Figure 3.8.2. Asphalt Oxidation Process Flow Diagram**

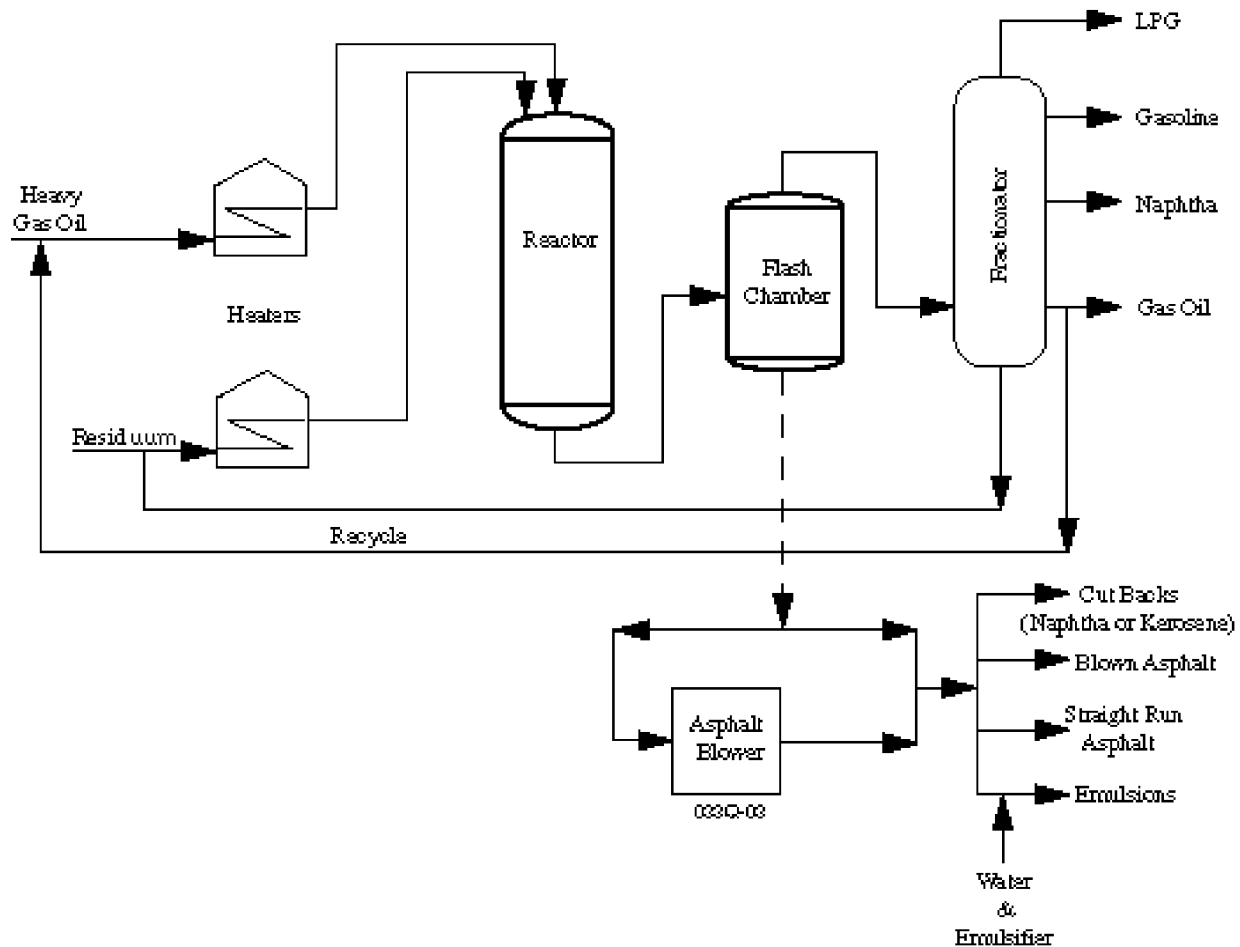

### Supercritical Extraction

The Residuum Oil Supercritical Extraction (ROSE) process is not, in a strict sense, a supercritical fluid extraction process. The primary extraction step is not carried out at supercritical conditions, but at liquid conditions that take advantage of the variable solvent power of a near-critical liquid. A simplified process flow diagram is provided in Figure 3.8.3. The first stage of the ROSE process consists of mixing residuum with compressed liquid butane or pentane and precipitating the undesired asphaltene fraction. Butane is used for its higher solvent power for heavy hydrocarbons. If an intermediate resin fraction is desired, another separator and stripper system would be used directly after the asphaltene separator. To recover a resin fraction, the overhead from the asphaltene separator is heated to near the critical temperature of the butane. At the elevated, near-critical temperature, the solvent power of the compressed liquid butane decreases and the resins precipitate from solution. The remaining fraction would consist of deasphalted light oils dissolved in butane. The butane is typically recovered using steam.



## 3.8.2 Off-specification Product from Residual Upgrading

### 3.8.2.1 Description

This residual was identified in the consent decree based on an incorrect characterization of data in a supporting document generated from 1983 PRDB data. After conducting a review of the underlying data, it was determined that volumes associated with the category of “off-specification product from residual upgrading” were actually process sludges generated during process upset conditions. The Agency's finding regarding this category was corroborated during its field investigation where this residual category was not identified and in the §3007 survey results. Generally, refineries re-work any residuum that does not initially meet product specifications within the upgrading process and rarely (one reported in 1992 in the §3007 survey) generate off-specification product for disposal.

### 3.8.2.2 Generation and Management

Off-spec product from residual upgrading includes material generated from asphalt oxidation, solvent deasphalting, and other upgrading processes. Residuals were assigned to be “off-specification product from residual upgrading” if they were assigned a residual identification code of “off-specification product” or “fines” and were generated from a process identified as a residual upgrading unit. These correspond to residual codes “05” and “06” in Section VII.2 of the questionnaire and process code “13” in Section IV-1.C of the questionnaire.

Based on the results of the questionnaire, 47 facilities use residual upgrading processes and thus could potentially generate off-specification product from residual upgrading. Only one facility reported this residual, generating 800 MT that was recovered within the process. The base year, 1992, was expected to be a typical year for residual upgrading processes and the survey results are in keeping with the Agency's understanding of this process. Table 3.8.1 provides a description of the quantity generated and number of reporting facilities.

**Table 3.8.1. Generation Statistics for Off-Specification Product from Residual Upgrading, 1992**

<b>Final Management</b>	<b># of Streams</b>	<b># of Streams w/ Unreported Volume</b>	<b>Total Volume (MT)</b>	<b>Average Volume (MT)</b>
Other recovery onsite: reuse in extraction process	1	0	800	800

### 3.8.2.3 Plausible Management

The Agency does not find it necessary to consider other management practices because off-spec product from residual upgrading had been classified as a residual of concern based on erroneous old data and in fact is not generated for disposal.

### 3.8.2.4 Characterization

Only one source of residual characterization data were developed during the industry study:

- Table 3.8.2 summarizes the physical properties of the off-specification product as reported in Section VII.A of the §3007 survey.

Because it is rarely generated, no record samples of this residual were available during record sampling for analysis.

**Table 3.8.2. Off-Specification Product from Residual Upgrading: Physical Properties**

Properties	# of Values	# of Unreported Values <sup>1</sup>	10th %	50th %	90th %
Flash Point, °C	1	2	99.00	99.00	99.00
Specific Gravity	1	2	1.02	1.02	1.02
Aqueous Liquid, %	1	2	40.00	40.00	40.00
Organic Liquid, %	1	2	60.00	60.00	60.00
Solid, %	1	2	100.00	100.00	100.00
Other, %	1	2	100.00	100.00	100.00

<sup>1</sup>Facilities were not required to do additional testing, therefore information provided was based on previously collected data or engineering judgment.

### 3.8.2.5 Source Reduction

No source reduction techniques were reported by industry or found in the literature search for this residual.

## 3.8.3 Process Sludge from Residual Upgrading

### 3.8.3.1 Description

Process sludge is generated from miscellaneous parts of the various residual upgrading processes. This category is neither uniform nor routinely generated. Solvent deasphalting may generate a sludge due to hydrocarbon carryover in the solvent recovery system. Similarly, the ROSE process may generate sludges due to process upsets in the solvent condensate collection system. Additional sludges may be generated during unit turnarounds and in surge drums and condensate knockout drums.

Three residuals were reported to be managed “as hazardous”, accounting for 25 percent of the volume of this category generated in 1992.<sup>1</sup>

### 3.8.3.2 Generation and Management

Twenty-one facilities reported generating a total quantity of 241 MT of this residual in 1992, according to the 1992 survey. Residuals were assigned to be “process sludge from residual upgrading” if they were assigned a residual identification code of “process sludge” and were generated from a process identified as a “residual upgrading” unit. These correspond to residual code “02-D” in Section VII.2 of the questionnaire and process code “13” in Section IV-1.C of the questionnaire.

Based on the results of the questionnaire, 47 facilities use residual upgrading units and thus may generate process sludge from residual upgrading. Due to the infrequent generation of this residual, not all of these 47 facilities generated sludge in 1992. However, there was no reason to expect that 1992 would not be a typical year with regard to this residual's generation and management. Table 3.8.3 provides a description of the quantity generated, number of streams reported, number of streams not reporting volumes (data requested was unavailable and facilities were not required to generate it), total and average volumes.

**Table 3.8.3. Generation Statistics for Process Sludge from Residual Upgrading, 1992**

Final Management	# of Streams	# of Streams w/ Unreported Volume	Total Volume (MT)	Average Volume (MT)
Discharge to onsite wastewater treatment facility	3	0	3.94	1.31
Disposal in offsite Subtitle D landfill	12	0	137.56	11.46
Disposal in offsite Subtitle C landfill	1	0	0.10	0.10
Disposal in onsite Subtitle C landfill	4	0	62.00	15.50
Disposal in onsite Subtitle D landfill	2	0	7.30	3.65
Offsite incineration	1	0	9.00	9.00
Other recycling, reclamation, or reuse: onsite road material	4	0	0.22	0.06
Recovery onsite via distillation	1	0	16.00	16.00
Transfer with coke product or other refinery product	4	0	5.44	1.36
<b>TOTAL</b>	<b>32</b>	<b>0</b>	<b>241.56</b>	<b>7.55</b>

<sup>1</sup>These percentages do not match up directly with any one of the management scenarios because the number of streams and the volume are a combination of several management scenarios (i.e., managed in WWTP, Subtitle C landfill, etc.).

### 3.8.3.3 Plausible Management

EPA believes that most of the plausible management practices for this residual were reported in the 1992 RCRA §3007 Survey, as summarized above in Table 3.8.3. The Agency gathered information suggesting that “recovery onsite in an asphalt production unit” (3.6 MT) and “transfer to offsite entity: unspecified” (unreported quantity) were used in other years. This non-1992 management practice is comparable with other recovery practices reported in 1992.

### 3.8.3.4 Characterization

Two sources of residual characterization data were developed during the industry study:

- Table 3.8.4 summarizes the physical properties of the sludge as reported in Section VII.A of the §3007 survey.
- One record sample of process sludge from residual upgrading was collected and analyzed by EPA. This sample is summarized in Table 3.8.5.

The sample was analyzed for total and TCLP levels of volatiles, semivolatiles, metals, and ignitability. The sample was found to exhibit the toxicity characteristic for benzene. A summary of the results is presented in Table 3.8.6. Only constituents detected in the sample are shown in this table.

### 3.8.3.5 Source Reduction

Source reduction techniques were reported to be process modifications and better housekeeping. This residual is generated infrequently and in very small quantities, therefore limited information was expected.

**Table 3.8.4. Process Sludge from Residual Upgrading: Physical Properties**

Properties	# of Values	# of Unreported Values <sup>1</sup>	10th %	50th %	90th %
pH	11	38	5.50	6.30	7.60
Reactive CN, ppm	8	41	0.01	0.74	50.00
Reactive S, ppm	7	42	0.01	15.00	4400.00
Flash Point, °C	14	35	82.22	94.17	315.56
Oil and Grease, vol%	7	42	0.10	9.00	100.00
Total Organic Carbon, vol%	16	33	50.00	98.50	100.00
Specific Gravity	12	37	0.90	1.08	1.85
BTU Content, BTU/lb	3	46	11.00	5,000.00	10,000.00
Aqueous Liquid, %	23	26	0.00	0.00	25.00
Organic Liquid, %	23	26	0.00	5.00	90.00
Solid, %	34	15	10.00	99.00	100.00
Other, %	18	31	0.00	0.00	2.00
Particle >60 mm, %	12	37	20.00	50.00	100.00
Particle 1-60 mm, %	9	40	1.00	49.00	80.00
Particle 100 µm-1 mm, %	5	44	0.00	1.00	1.00
Particle 10-100 µm, %	1	48	0.00	0.00	0.00
Particle <10 µm, %	1	48	0.00	0.00	0.00
Median Particle Diameter, microns	1	48	60.00	60.00	60.00

<sup>1</sup>Facilities were not required to do additional testing, therefore information provided was based on previously collected data or engineering judgment.

**Table 3.8.5. Process Sludge from Residual Upgrading Record Sampling Locations**

Sample Number	Location	Description
R1-RU-01	Marathon, Indianapolis, IN	ROSE unit scale/sludge

**Table 3.8.6. Process Sludge from Residual Upgrading Characterization**

<b>Volatile Organics - Method 8260A µg/kg</b>			
	<b>CAS No.</b>	<b>R1-RU-01</b>	<b>Comments</b>
Acetone	67641	B 120,000	
Benzene	71432	73,000	
Ethylbenzene	100414	130,000	
Methylene chloride	75092	64,000	
4-Methyl-2-pentanone	108101	63,000	
n-Propylbenzene	103651	65,000	
Toluene	108883	310,000	
1,2,4-Trimethylbenzene	95636	570,000	
1,3,5-Trimethylbenzene	108678	150,000	
o-Xylene	95476	230,000	
m,p-Xylenes	108383 / 106423	690,000	
Naphthalene	91203	160,000	
<b>TCLP Volatile Organics - Methods 1311 and 8260A µg/L</b>			
	<b>CAS No.</b>	<b>R1-RU-01</b>	<b>Comments</b>
Benzene	71432	2,600	
Ethylbenzene	100414	570	
Toluene	108883	4,100	
1,2,4-Trimethylbenzene	95636	990	
o-Xylene	95476	1,300	
m,p-Xylene	108383 / 106423	2,800	
<b>Semivolatile Organics - Method 8270B µg/kg</b>			
	<b>CAS No</b>	<b>R1-RU-01</b>	<b>Comments</b>
Acenaphthene	83329	J 38,000	
Anthracene	120127	J 13,000	
Dibenzofuran	132649	J 13,000	
Fluorene	86737	J 39,000	
Phenanthrene	85018	120,000	
Pyrene	129000	J 19,000	
1-Methylnaphthalene	90120	390,000	
2-Methylnaphthalene	91576	570,000	
Naphthalene	91203	190,000	
<b>TCLP Semivolatile Organics - Methods 1311 and 8270B µg/L</b>			
	<b>CAS No.</b>	<b>R1-RU-01</b>	<b>Comments</b>
Bis(2-ethylhexyl)phthalate	117817	J 30	
2,4-Dimethylphenol	105679	J 52	
Indene	95136	J 16	
1-Methylnaphthalene	90120	J 96	
2-Methylnaphthalene	91576	130	



**Table 3.8.6. Process Sludge from Residual Upgrading Characterization (continued)**

<b>TCLP Semivolatile Organics - Methods 1311 and 8270B µg/L (continued)</b>			
	<b>CAS No.</b>	<b>R1-RU-01</b>	<b>Comments</b>
2-Methylphenol	95487	J 65	
3/4-Methylphenol	NA	J 85	
Naphthalene	91203	190	
Phenol	108952	J 57	
<b>Total Metals - Methods 6010, 7060, 7421, 7470, 7471, and 7841 mg/kg</b>			
	<b>CAS No.</b>	<b>R1-RU-01</b>	<b>Comments</b>
Aluminum	7429905	150	
Antimony	7440360	14.0	
Arsenic	7440382	43.0	
Barium	7440393	41.0	
Cadmium	7440439	1.10	
Calcium	7440702	15,000	
Chromium	7440473	86.0	
Cobalt	7440484	13.0	
Copper	7440508	92.0	
Iron	7439896	200,000	
Lead	7439921	20.0	
Magnesium	7439954	6,500	
Manganese	7439965	770	
Mercury	7439976	0.11	
Molybdenum	7439987	24.0	
Nickel	7440020	90.0	
Vanadium	7440622	100	
Zinc	7440666	40.0	
<b>TCLP Metals - Methods 1311, 6010, 7060, 7421, 7470, 7471, and 7841 mg/L</b>			
	<b>CAS No.</b>	<b>R1-RU-01</b>	<b>Comments</b>
Calcium	7440702	130	
Iron	7439896	120	
Manganese	7439965	3.90	
Zinc	7440666	0.24	
<b>Miscellaneous Characterization</b>			
		<b>R1-RU-01</b>	<b>Comments</b>
Ignitability ( oF )		199	

Notes:

- B Analyte also detected in the associated method blank.
- J Compound's concentration is estimated. Mass spectral data indicate the presence of a compound that meets the identification criteria for which the result is less than the laboratory detection limit, but greater than zero.

## 3.9 LUBE OIL PROCESSING

Vacuum distillates are treated and refined to produce a variety of lubricants. Wax, aromatics, and asphalts are removed by unit operations such as solvent extraction and hydroprocessing; clay may also be used. Various additives are used to meet product specifications for thermal stability, oxidation resistances, viscosity, pour point, etc.

### 3.9.1 Process Descriptions

The manufacture of lubricating oil base stocks consists of five basic steps:

- 1) Distillation
- 2) Deasphalting to prepare the feedstocks
- 3) Solvent or hydrogen refining to improve viscosity index and quality
- 4) Solvent or catalytic dewaxing to remove wax and improve low temperature properties of paraffinic lubes
- 5) Clay or hydrogen finishing to improve color, stability, and quality of the lube base stock.

Based on results of the 1992 survey, 22 facilities reported conducting lube oil processing. The finished lube stocks are blended with each other and additives using batch and continuous methods to produce formulated lubricants. The most common route to finishing lube feedstocks consists of solvent refining, solvent dewaxing, and hydrogen finishing. The solvent and clay processing route or the hydrogen refining and solvent dewaxing route are also used. The all-hydrogen processing (lube hydrocracking-catalytic dewaxing-hydrorefining) route is used by two refiners for the manufacture of a limited number of paraffinic base oils. Figure 3.9.1 provides a general process flow diagram for lube oil processing.

#### Lube Distillation

Lube processing may be the primary production process at some facilities, while at others it is only one of many operations. The initial step is to separate the crude into the fractions which are the raw stocks for the various products to be produced. The basic process consists of an atmospheric distillation unit and a vacuum distillation unit. The majority of the lube stocks boil in the range between 580°F and 1000°F and are distilled in the vacuum unit to the proper viscosity and flash specifications. Caustic solutions are sometimes introduced to the feed to neutralize organic acids present in some crude oils. This practice reduces or eliminates corrosion in downstream processing units, and improves color, stability, and refining response of lube distillates.

**Figure 3.9.1. Lube Oil Processing Flow Diagram**

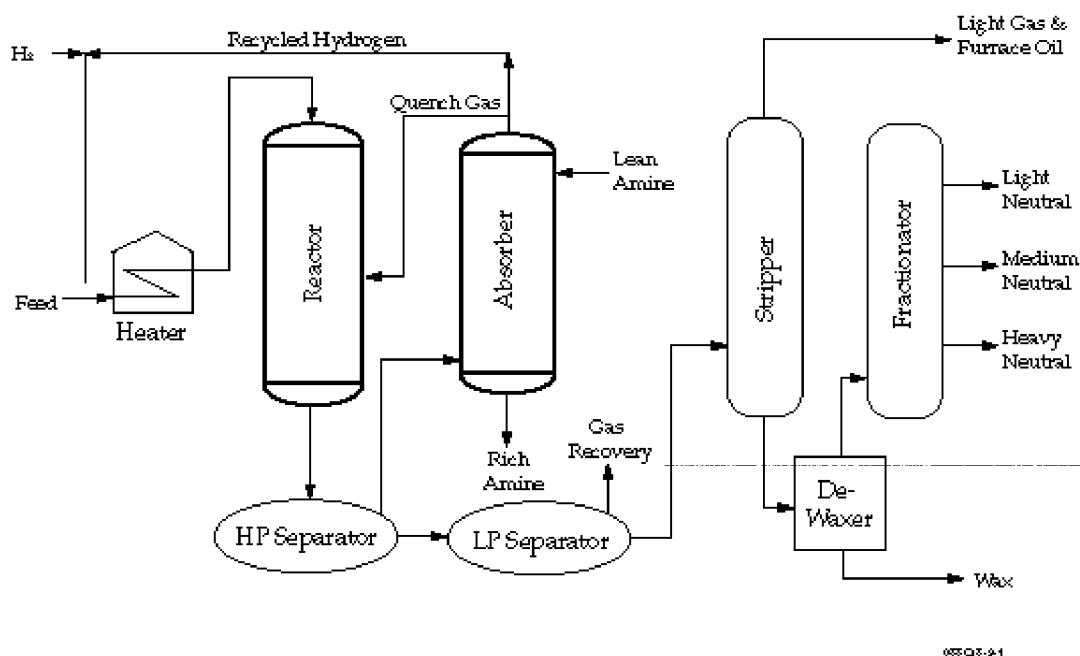

## Lube Deasphalting

Other facilities incorporate lube deasphalting to process vacuum residuum into lube oil base stocks. Propane deasphalting is most commonly used to remove asphaltenes and resins which contribute an undesirable dark color to the lube base stocks. This process typically uses baffle towers or rotating disk contactors to mix the propane with the feed. Solvent recovery is accomplished with evaporators, and supercritical solvent recovery processes are also used in some deasphalting units. Another deasphalting process is the Duo-Sol Process that is used to both deasphalt and extract lubricating oil feedstocks. Propane is used as the deasphalting solvent and a mixture of phenol and cresylic acids are used as the extraction solvent. The extraction is conducted in a series of batch extractors followed by solvent recovery in multistage flash distillation and stripping towers. See the section on Residual Upgrading for additional discussion on these processes.

## Lube Refining Processes

Chemical, solvent, and hydrogen refining processes have been developed and are used to remove aromatics and other undesirable constituents, and to improve the viscosity index and quality of lube base stocks. Traditional chemical processes that use sulfuric acid and clay refining have been replaced by solvent extraction/refining and hydrotreating which are more effective, cost efficient, and environmentally more acceptable. Chemical refining is used most often for the reclamation of used lubricating oils or in combination with solvent or hydrogen refining processes for the manufacture of specialty lubricating oils and by-products.

Chemical Refining Processes: Acid-alkali refining, also called “wet refining”, is a process where lubricating oils are contacted with sulfuric acid followed by neutralization with

alkali. Oil and acid are mixed and an acid sludge is allowed to coagulate. The sludge is removed or the oil is decanted after settling, and more acid is added and the process repeated.

Acid-clay refining, also called “dry refining” is similar to acid-alkali refining with the exception that clay and a neutralizing agent are used for neutralization. This process is used for oils that form emulsions during neutralization.

Neutralization with aqueous and alcoholic caustic, soda ash lime, and other neutralizing agents is used to remove organic acids from some feedstocks. This process is conducted to reduce organic acid corrosion in downstream units or to improve the refining response and color stability of lube feedstocks.

Hydrogen Refining Processes: Hydrogen refining, also called hydrotreating, has since been replaced with solvent refining processes which are more cost effective. Hydrotreating consists of lube hydrocracking as an alternative to solvent extraction, and hydrorefining to prepare specialty products or to stabilize hydrocracked base stocks. Hydrocracking catalysts are proprietary to the licensors and consist of mixtures of cobalt, nickel, molybdenum, and tungsten on an alumina or silica-alumina-based carrier. Hydrorefining catalysts are proprietary but usually consist of nickel-molybdenum on alumina.

Lube hydrocracking are used to remove nitrogen, oxygen, and sulfur, and convert the undesirable polynuclear aromatics and polynuclear naphthenes to mononuclear naphthenes, aromatics, and isoparaffins which are typically desired in lube base stocks. Feedstocks consist of unrefined distillates and deasphalted oils, solvent extracted distillates and deasphalted oils, cycle oils, hydrogen refined oils, and mixtures of these hydrocarbon fractions.

Lube hydrorefining processes are used to stabilize or improve the quality of lube base stocks from lube hydrocracking processes and for manufacture of specialty oils. Feedstocks are dependent on the nature of the crude source but generally consist of waxy or dewaxed-solvent-extracted or hydrogen-refined paraffinic oils and refined or unrefined naphthenic and paraffinic oils from some selected crudes.

Solvent Refining Processes: Feedstocks from solvent refining processes consist of paraffinic and naphthenic distillates, deasphalted oils, hydrogen refined distillates and deasphalted oils, cycle oils, and dewaxed oils. The products are refined oils destined for further processing or finished lube base stocks. The by-products are aromatic extracts which are used in the manufacture of rubber, carbon black, petrochemicals, FCCU feed, fuel oil, or asphalt. The major solvents used today are N-methyl-2-pyrrolidone (NMP) and furfural, with phenol and liquid sulfur dioxide used to a lesser extent.

The solvents are typically recovered in a series of flash towers. Steam or inert gas strippers are used to remove traces of solvent, and a solvent purification system is used to remove water and other impurities from the recovered solvent.

## Lube Dewaxing Processes

Lube feedstocks typically contain increased wax content resulting from deasphalting and refining processes. These waxes are normally solid at ambient temperatures and must be removed to manufacture lube oil products with the necessary low temperature properties. Catalytic dewaxing and solvent dewaxing (the most prevalent) are processes currently in use; older technologies include cold settling, pressure filtration, and centrifuge dewaxing.

Catalytic Dewaxing: Because solvent dewaxing is relatively expensive for the production of low pour point oils, various catalytic dewaxing (selective hydrocracking) processes have been developed for the manufacture of lube oil base stocks. The basic process consists of a reactor containing a proprietary dewaxing catalyst followed by a second reactor containing a hydrogen finishing catalyst to saturate olefins created by the dewaxing reaction and to improve stability, color and demulsibility of the finished lube oil.

Solvent Dewaxing: Solvent dewaxing consists of the following steps: crystallization, filtration, and solvent recovery. In the crystallization step, the feedstock is diluted with the solvent and chilled, solidifying the wax components. The filtration step removes the wax from the solution of dewaxed oil and solvent. Solvent recovery removes the solvent from the wax cake and filtrate for recycle by flash distillation and stripping. The major processes in use today are the ketone dewaxing processes. Other processes that are used to a lesser degree include the Di/Me Process and the propane dewaxing process.

The most widely used ketone processes are the Texaco Solvent Dewaxing Process and the Exxon Dilchill Process. Both processes consist of diluting the waxy feedstock with solvent while chilling at a controlled rate to produce a slurry. The slurry is filtered using rotary vacuum filters and the wax cake is washed with cold solvent. The filtrate is used to prechill the feedstock and solvent mixture. The primary wax cake is diluted with additional solvent and filtered again to reduce the oil content in the wax. The solvent recovered from the dewaxed oil and wax cake by flash vaporization and recycled back into the process. The Texaco Solvent Dewaxing Process (also called the MEK process) uses a mixture of MEK and toluene as the dewaxing solvent, and sometimes uses mixtures of other ketones and aromatic solvents. The Exxon Dilchill Dewaxing Process uses a direct cold solvent dilution-chilling process in a special crystallizer in place of the scraped surface exchangers used in the Texaco process.

The Di/Me Dewaxing Process uses a mixture of dichloroethane and methylene dichloride as the dewaxing solvent. This process is used by a few refineries in Europe. The Propane Dewaxing Process is essentially the same as the ketone process except for the following: propane is used as the dewaxing solvent and higher pressure equipment is required, and chilling is done in evaporative chillers by vaporizing a portion of the dewaxing solvent. Although this process generates a better product and does not require crystallizers, the temperature differential between the dewaxed oil and the filtration temperature is higher than for the ketone processes (higher energy costs), and dewaxing aids are required to get good filtration rates.

## Lube Oil Finishing Processes

Today, hydrogen finishing processes (also referred to as hydrorefining) have largely replaced the more costly acid and clay finishing processes. Hydrogen finishing processes are mild hydrogenation processes used to improve the color, odor, thermal, and oxidative stability, and demulsibility of lube base stocks. The process consists of fixed bed catalytic reactors that typically use a nickel-molybdenum catalyst to neutralize, desulfurize, and denitrify lube base stocks. These processes do not saturate aromatics or break carbon-carbon bonds as in other hydrogen finishing processes. Sulfuric acid treating is still used by some refiners for the manufacture of specialty oils and the reclamation of used oils. This process is typically conducted in batch or continuous processes similar to the chemical refining processes discussed earlier, with the exception that the amount of acid used is much lower than used in acid refining. Clay contacting involves mixing the oil with fine bleaching clay at elevated temperature followed by separation of the oil and clay. This process improves color and chemical, thermal, and color stability of the lube base stock, and is often combined with acid finishing. Clay percolation is a static bed absorption process used to purify, decolorize, and finish lube stocks and waxes. It is still used in the manufacture of refrigeration oils, transformer oils, turbine oils, white oils, and waxes.

### 3.9.2 Treating Clay from Lube Oil Processing

#### 3.9.2.1 Description

The majority of treating clays (including other sorbents) generated from lube oil processing are from acid-clay treating in refining or lube oil finishing. The average volume is approximately 40 metric tons.

#### 3.9.2.2 Generation and Management

The spent clay is vacuumed or gravity dumped from the vessels into piles or into containers such as drums and roll-off bins. Only one residual was reported to be managed “as hazardous” from this category in 1992.

Seven facilities reported generating a total quantity of approximately 733 metric tons of this residual in 1992, according to the 1992 RCRA §3007 Questionnaire. Residual were assigned to be “treating clay from lube oil processes” if they were assigned a residual identification code of “spent sorbent” and were generated from a lube oil process. These correspond to residual code “05” in Section VII.A of the questionnaire and process code “17” in Section IV.C of the questionnaire. Table 3.9.1 provides a description of the 1992 management practices, quantity generated, number of streams reported, number of streams not reporting volumes (data requested was unavailable and facilities were not required to generate it), total and average volumes.

**Table 3.9.1. Generation Statistics for Treating Clay from Lube Oil, 1992**

<b>Final Management</b>	<b># of Streams</b>	<b># of Streams w/ Unreported Volume</b>	<b>Total Volume (MT)</b>	<b>Average Volume (MT)</b>
Disposal in offsite Subtitle D landfill	1	1	36.7	36.7
Disposal in offsite Subtitle C landfill	2	0	78.7	39.4
Disposal in onsite Subtitle C landfill	1	0	5	5
Onsite land treatment	1	0	9.8	9.8
Other recycling, reclamation, or reuse: cement plant	1	0	249.2	249.2
Other recycling, reclamation, or reuse: onsite regeneration	12	0	354	29.5
<b>TOTAL</b>	<b>18</b>	<b>1</b>	<b>733.4</b>	<b>40.7</b>

### 3.9.2.3 Plausible Management

EPA believes that most of the plausible management practices for this residual were reported in the 1992 RCRA §3007 Survey, as summarized above in Table 3.9.1. No data were available to the Agency suggesting any other management practices. In addition, EPA compared the management practice reported for lube oil treating clay to those reported for treating clays from extraction, alkylation, and isomerization<sup>2</sup> based on expected similarities. No additional management practices were reported.

### 3.9.2.4 Characterization

Two sources of residual characterization were developed during the industry study:

- Table 3.9.2 summarizes the physical and chemical properties of treating clay from lube oil processes as reported in Section VII.A of the §3007 survey.
- One record sample of treating clay from lube oil processes was collected and analyzed by EPA. Sampling information is summarized in Table 3.9.3.

The collected sample is expected to be generally representative of treating clay from lube oil processes. The sample was analyzed for total and TCLP levels of volatiles, semi-volatiles, and metals. The sample did not exhibit any of the hazardous waste characteristics. A summary of the analytical results is presented in Table 3.9.4. Only constituents detected in the sample are reported.

---

<sup>2</sup>EPA did not compare these management practices to those reported for the broader category of “treating clay from clay filtering” due to the diverse types of materials included in this miscellaneous category.

**Table 3.9.2. Treating Clay from Lube Oil: Physical Properties**

Properties	# of Values	# of Unreported Values	10th %	50th %	90th %
pH	3	17	3.80	7.40	7.40
Flash Point, °C	2	18	95.00	95.00	95.00
Oil and Grease, vol%	12	8	1.00	1.00	1.00
Total Organic Carbon, vol%	12	8	1.00	1.00	1.00
Specific Gravity	15	5	0.90	3.20	3.20
Aqueous Liquid, %	4	16	0.00	0.00	0.00
Organic Liquid, %	4	16	0.00	0.00	0.00
Solid, %	7	13	100.00	100.00	100.00
Particle >60 mm, %	2	18	0.00	0.00	0.00
Particle 1-60 mm, %	2	18	0.00	45.80	91.60
Particle 100 µm-1 mm, %	2	18	8.40	54.20	100.00
Particle 10-100 µm, %	4	16	0.00	50.00	100.00
Particle <10 µm, %	2	18	0.00	0.00	0.00
Median Particle Diameter, microns	2	18	0.00	400.00	800.00

<sup>1</sup>Facilities were not required to do additional testing, therefore information provided was based on previously collected data or engineering judgment.

**Table 3.9.3. Treating Clay from Lube Oil Processing Record Sampling Locations**

Sample Number	Location	Description
R13-CL-01	Shell, Deer Park, TX	Pellets from wax treating

### 3.9.3.5 Source Reduction

This residual is generated infrequently and in very small quantities. Treating clays use for product polishing in lube oil manufacturing are being phased out by industry. No source reduction methods were reported by industry or found in the literature search.



**Table 3.9.4. Treating Clay from Lube Oil Processing Characterization**

<b>Volatile Organics - Method 8260A µg/kg</b>			
	<b>CAS No.</b>	<b>R13-CL-01</b>	<b>Comments</b>
Benzene	71432	11	
Ethylbenzene	100414	J 8	
Methylene chloride	75092	24	
n-Propylbenzene	103651	J 8	
Toluene	108883	31	
1,2,4-Trimethylbenzene	95636	78	
1,3,5-Trimethylbenzene	108678	34	
o-Xylene	95476	18	
m,p-Xylenes	108383 / 106423	52	
<b>TCLP Volatile Organics - Methods 1311 and 8260A µg/L</b>			
	<b>CAS No.</b>	<b>R13-CL-01</b>	<b>Comments</b>
Methylene chloride	75092	B 2,600	
<b>Semivolatile Organics - Method 8270B µg/kg</b>			
	<b>CAS No</b>	<b>R13-CL-01</b>	<b>Comments</b>
Bis(2-ethylhexyl)phthalate	117817	38,000	
Di-n-butyl phthalate	84742	J 390	
N-Nitrosodiphenylamine	86306	J 470	
<b>TCLP Semivolatile Organics - Methods 1311 and 8270B µg/L</b>			
	<b>CAS No.</b>	<b>R13-CL-01</b>	<b>Comments</b>
2-Methylphenol	95487	J 18	
3/4-Methylphenol	NA	J 18	
<b>Total Metals - Methods 6010, 7060, 7421, 7470, 7471, and 7841 mg/kg</b>			
	<b>CAS No.</b>	<b>R13-CL-01</b>	<b>Comments</b>
Aluminum	7429905	140,000	
Barium	7440393	53.0	
Calcium	7440702	1,300	
Chromium	7440473	100	
Copper	7440508	260	
Iron	7439896	19,000	
Lead	7439921	36.0	
Manganese	7439965	180	
Vanadium	7440622	130	
Zinc	7440666	120	

**Table 3.9.4. Treating Clay from Lube Oil Processing Characterization (continued)**

<b>TCLP Metals - Methods 1311, 6010, 7060, 7421, 7470, 7471, and 7841 mg/L</b>			
	<b>CAS No.</b>	<b>R13-CL-01</b>	<b>Comments</b>
Aluminum	7429905	12.0	
Copper	7440508	0.90	
Manganese	7439965	1.50	
Zinc	7440666	B	0.94
<b>Miscellaneous Characterization</b>			
		<b>R13-CL-01</b>	<b>Comments</b>
Ignitability ( oF )		NA	

Comments:

- 1 Detection limits greater than the highest detected concentration are excluded from the calculations.

Notes:

- B Analyte also detected in the associated method blank.
- J Compound's concentration is estimated. Mass spectral data indicate the presence of a compound that meets the identification criteria for which the result is less than the laboratory detection limit, but greater than zero.
- ND Not Detected.
- NA Not Applicable.

## 3.10 H<sub>2</sub>S REMOVAL AND SULFUR COMPLEX

### 3.10.1 Process Description

All crude oil contains sulfur, which must be removed at various points of the refining process. The predominant technique for treating light petroleum gases is (1) amine scrubbing followed by (2) recovery of elemental sulfur in a Claus unit followed by (3) final sulfur removal in a tail gas unit. This dominance is shown in Table 3.10.1, which presents the sulfur complex/removal processes reported in the RCRA §3007 Survey.

**Table 3.10.1. Sulfur Removal Technologies Reported in RCRA §3007 Questionnaire**

Technique	Number of Facilities	Percentage of Facilities <sup>1</sup>
Amine-based sulfur removal	106	86
Claus sulfur recovery <sup>2</sup>	101	82
Other sulfur removal or recovery	16	13
SCOT®-type tail gas unit <sup>3</sup>	50	41
Other tail gas treating unit <sup>4</sup>	19	15

<sup>1</sup>Percentage of the 123 facilities reporting any sulfur removal/complex technique.

<sup>2</sup>Note that more facilities perform sulfur removal than perform sulfur recovery. Some refineries transfer their H<sub>2</sub>S-containing amine offsite to another nearby refinery.

<sup>3</sup>Shell and other companies license similar technologies. All are included here as "SCOT®-type."

<sup>4</sup>14 facilities use the Beavon-Stretford process for tail gas treating.

Caustic or water is often used in conjunction with, or instead of, amine solution to remove sulfur, particularly for liquid petroleum fractions. These processes, however, are generally not considered sulfur removal processes because either (1) the sulfur is not further complexed from these solutions (i.e., is not removed from the solution), or (2) if removed, it occurs in a sour water stripper which is in the domain of the facility's wastewater treatment system. Such processes are considered to be liquid treating with caustic, which was discussed in the Listing Background Document.

The dominant sulfur removal/complex train, amine scrubbing followed by Claus unit followed by SCOT®-type tail gas treating, is discussed below. In addition, the second-most popular tail gas system, the Beavon-Stretford system, is discussed. Finally, other processes reported in the questionnaires are discussed.

### 3.10.1.1 Amine Scrubbing

As shown in Table 3.10.1, amine scrubbing is used by most facilities, with 106 refineries reporting this process in the questionnaire. A typical process flow diagram for an amine scrubbing system is shown in Figure 3.10.1. The purpose of the unit is to remove H<sub>2</sub>S from refinery fuel gas for economical downstream recovery. Fuel gas from the refinery is fed to a countercurrent absorber with a 25 to 30 percent aqueous solution of amine such as monoethanolamine (MEA), diethanolamine (DEA), or methyldiethanolamine (MDEA). The H<sub>2</sub>S reacts with the amine solution to form a complex, “rich” amine. Typically, a refinery will have several absorbers located throughout the refinery depending on the location of service. These “rich” streams are combined and sent to a common location at the sulfur plant where the H<sub>2</sub>S is stripped from the amine in the reverse reaction. The “lean” amine is recycled back to the absorbers.

**Figure 3.10.1. Amine Sulfur Removal Process Flow Diagram**

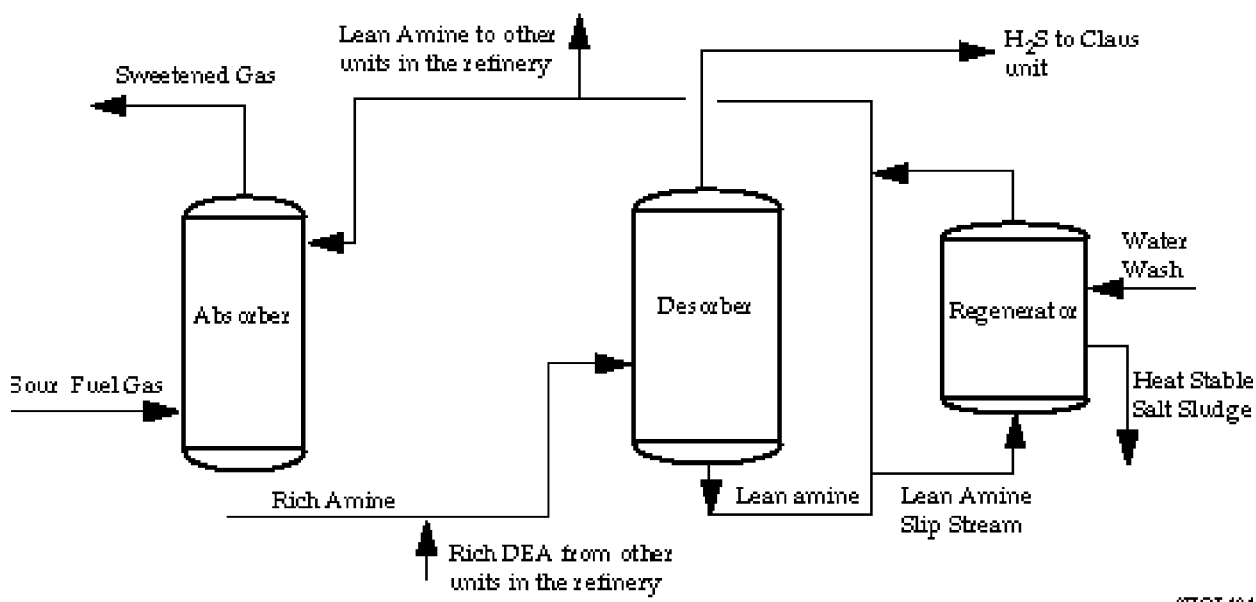

### 3.10.1.2 Claus Unit

The H<sub>2</sub>S from the sulfur removal unit is most often recovered in a Claus system as elemental sulfur. Table 3.10.1 shows that 101 refineries reported this process in the questionnaire. A typical process flow diagram for a Claus unit is shown in Figure 3.10.2. In a Claus unit, the H<sub>2</sub>S is partially combusted with air to form a mixture of SO<sub>2</sub> and H<sub>2</sub>S. It then passes through a reactor containing activated alumina catalyst to form sulfur by the following endothermic reaction:

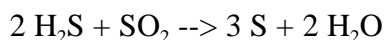

The reaction is typically conducted at atmospheric pressure. The resulting sulfur is condensed to its molten state, drained to a storage pit, and reheated. The typical Claus unit consists of three such reactor/condenser/reheaters to achieve an overall sulfur removal yield of 90 to 95 percent.

At this point the tail gas can be (1) combusted and released to the atmosphere, or (2) sent to a tail gas unit to achieve greater sulfur reduction.

**Figure 3.10.2. Claus Sulfur Recovery Process Flow Diagram**

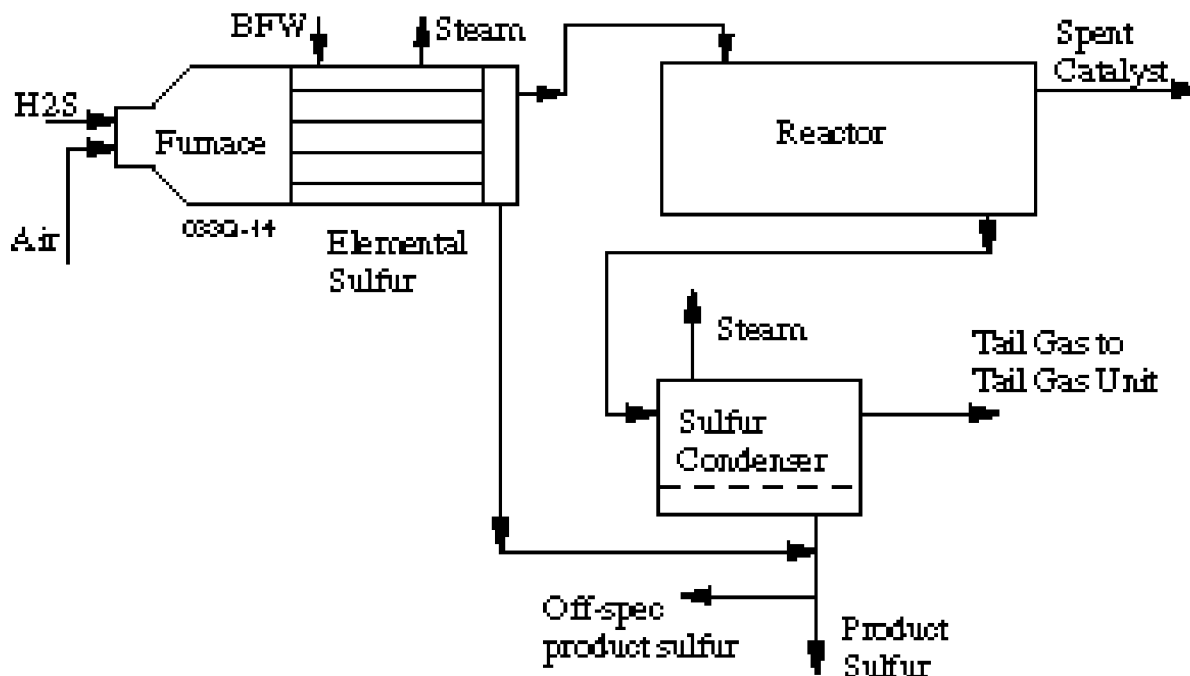

### 3.10.1.3 SCOT<sup>®</sup> Tailgas Unit

The most common type of tail gas unit uses a hydrotreating reactor followed by amine scrubbing to recover and recycle sulfur, in the form of H<sub>2</sub>S, to the Claus unit. Shell licenses this technology as the Shell Claus Offgas Treating (SCOT<sup>®</sup>) unit; many other refineries reported using similar designs licensed by other vendors. All can be represented by the generalized process flow diagram shown in Figure 3.10.3.

Tail gas (containing H<sub>2</sub>S and SO<sub>2</sub>) is contacted with H<sub>2</sub> and reduced in a hydrotreating reactor to form H<sub>2</sub>S and H<sub>2</sub>O. The catalyst is typically cobalt/molybdenum on alumina. The gas is then cooled in a water contractor. The water circulates in the column and requires periodic purging due to impurity buildup; filters may be used to control levels of particulates or impurities in the circulating water.

The H<sub>2</sub>S-containing gas enters an amine absorber which is typically in a system segregated from the other refinery amine systems discussed above. The purpose of segregation is two-fold: (1) the tail gas treater frequently uses a different amine than the rest of the plant, such as MDEA or diisopropyl amine (DIPA), and (2) the tail gas is frequently cleaner than the refinery fuel gas (in regard to contaminants) and segregation of the systems reduces maintenance requirements for the SCOT<sup>®</sup> unit. Amines chosen for use in the tail gas system tend to be more selective for H<sub>2</sub>S and are not affected by the high levels of CO<sub>2</sub> in the offgas.

The “rich” amine generated from this step is desorbed in a stripper; the lean amine is recirculated while the liberated H<sub>2</sub>S is sent to the Claus unit. Particulate filters are sometimes used to remove contaminants from lean amine.

**Figure 3.10.3. SCOT® Tail Gas Sulfur Removal Process Flow Diagram**

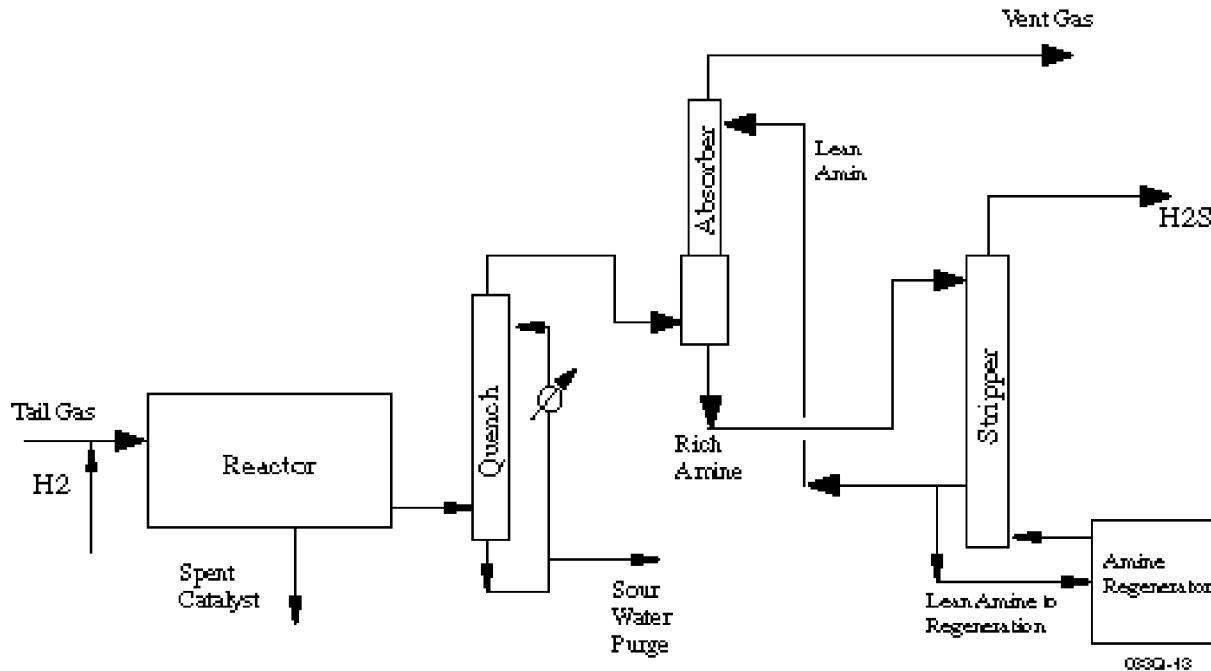

#### 3.10.1.4 Beavon-Stretford Tail Gas Unit

This system was reported to be used by 14 facilities. A hydrotreating reactor converts SO<sub>2</sub> in the offgas to H<sub>2</sub>S. The generated H<sub>2</sub>S is contacted with Stretford solution (a mixture of vanadium salt, anthraquinone disulfonic acid (ADA), sodium carbonate, and sodium hydroxide) in a liquid-gas absorber. The H<sub>2</sub>S reacts stepwise with sodium carbonate and ADA to produce elemental sulfur, with vanadium serving as a catalyst. The solution proceeds to a tank where oxygen is added to regenerate the reactants. One or more froth or slurry tanks are used to skim the product sulfur from the solution, which is recirculated to the absorber.

#### 3.10.1.5 Other Processes

Although the amine/Claus train followed by a SCOT® or Beavon-Stretford tail gas unit is the dominant system used in the industry, it is not exclusive. Some refineries, mostly small asphalt plants, do not require sulfur removal processes at all, while others use alternative technologies. Each of these processes are used by less than five refineries, and most often are used by only one or two facilities. In decreasing order of usage, these other processes are as follows:

## Sulfur Removal/Recovery Processes

**Sodium Hydrosulfide:** Fuel gas containing H<sub>2</sub>S is contacted with sodium hydroxide in an absorption column. The resulting liquid is product sodium hydrosulfide (NaHS).

**Iron Chelate:** Fuel gas containing H<sub>2</sub>S is contacted with iron chelate catalyst dissolved in solution. H<sub>2</sub>S is converted to elemental sulfur, which is recovered.

**Stretford:** Similar to iron chelate, except Stretford solution is used instead of iron chelate solution.

**Ammonium Thiosulfate:** In this process, H<sub>2</sub>S is contacted with air to form SO<sub>2</sub>. The SO<sub>2</sub> is contacted with ammonia in a series of absorption column to produce ammonium thiosulfate for offsite sale. (Kirk-Othmer, 1983)

**Hyperion:** Fuel gas is contacted over a solid catalyst to form elemental sulfur. The sulfur is collected and sold. The catalyst is comprised of iron and naphthoquinonsulfonic acid.

**Sulfatreat:** The Sulfatreat material is a black granular solid powder; the H<sub>2</sub>S forms a chemical bond with the solid. When the bed reaches capacity, the Sulfatreat solids are removed and replaced with fresh material. The sulfur is not recovered.

A few facilities report sour water stripping, which was not part of the scope of the survey. The actual number of sour water strippers is likely to be much greater than reported in the questionnaire.

**Hysulf:** This process is under development by Marathon Oil Company and was not reported by any facilities in the questionnaire. Hydrogen sulfide is contacted with a liquid quinone in an organic solvent such as n-methyl-2-pyrrolidone (NMP), forming sulfur. The sulfur is removed and the quinone reacted to its original state, producing hydrogen gas (*The National Environmental Journal*, March/April 1995).

## Tail Gas Processes

**Caustic Scrubbing:** An incinerator converts trace sulfur compounds in the offgas to SO<sub>2</sub>. The gas is contacted with caustic which is sent to the wastewater treatment system.

**Polyethylene Glycol:** Offgas from the Claus unit is contacted with this solution to generate an elemental sulfur product. Unlike the Beavon Stretford process, no hydrogenation reactor is used to convert SO<sub>2</sub> to H<sub>2</sub>S. (Kirk-Othmer, 1983)

**Selectox:** A hydrogenation reactor converts SO<sub>2</sub> in the offgas to H<sub>2</sub>S. A solid catalyst in a fixed bed reactor converts the H<sub>2</sub>S to elemental sulfur. The elemental sulfur is recovered and sold. (*Hydrocarbon Processing*, April 1994).

**Sulfite/Bisulfite Tail Gas Treating Unit:** Following Claus reactors, an incinerator converts trace sulfur compounds to SO<sub>2</sub>. The gas is contacted with sulfite solution in an

absorber, where SO<sub>2</sub> reacts with the sulfite to produce a bisulfite solution. The gas is then emitted to the stack. The bisulfite is regenerated and liberated SO<sub>2</sub> is sent to the Claus units for recovery. (Kirk-Othmer, 1983)

### 3.10.2 Off-Specification Product from Sulfur Complex and H<sub>2</sub>S Removal Facilities

#### 3.10.2.1 Description

Elemental sulfur is the most common product from sulfur complex and H<sub>2</sub>S removal facilities, although a small number of facilities generate product sodium hydrosulfide or ammonium thiosulfate, as discussed in Section 3.10.1.5. Like other refinery products, sulfur must meet certain customer specifications such as color and impurity levels. The failure of the refinery to meet these requirements causes the sulfur to be “off-spec.”

#### **Stretford System**

Although the Beavon-Stretford system is used by only 14 refineries, off-spec sulfur generated from this process accounts for 2/3 of the refinery-wide 1992 generation of off-spec sulfur. Sources of this volume are as follows:

- **Product sulfur:** Some refineries routinely dispose of their continuously generated product sulfur rather than sell it. Presumably, these refineries have operational difficulties making “on-spec” sulfur from the vanadium-catalyzed process. The small number of refineries managing sulfur this way account for most of the quantity of off-spec sulfur generated industry-wide. Other refineries sell all or most of their product sulfur and only dispose of sulfur generated from spills, etc.
- **Filtered solids from spent Stretford solution:** As discussed further in Section 3.10.3, many refineries report that a portion of the circulating Stretford solution must be purged to remove impurities in the system. After purging, some refineries filter out the solids prior to further managing the spent solution.
- **Turnaround sludge (sediment):** Every few years, the process units are thoroughly cleaned as preparation for maintenance. The principal source of this turnaround sludge is the froth (slurry) tank.
- **Miscellaneous sludges (sediments):** Other solids build up in the system, including tank sludges and process drain pit sludge. They are removed intermittently.

Every residual generated by the Stretford process contains elemental (product) sulfur because sulfur is a reaction product. Most refineries designated the above materials as off-spec product in their questionnaire response, and these residuals are included in statistics discussed later in this Section.



## Claus System

Based on database responses, many Claus units generate off-spec sulfur at frequencies ranging from 2 months to 2 years. Sources of such sulfur are spills, process upsets, turnarounds, or maintenance operations. Some refineries generate off-spec sulfur more frequently; one refinery reports that certain spots are drained daily to ensure proper operation.

## Other Systems

The amine scrubbing and SCOT<sup>®</sup> units do not generate off-spec sulfur because they do not generate product sulfur (their product is H<sub>2</sub>S, an intermediate for the Claus sulfur recovery unit). Other systems generating elemental sulfur or product sulfur compounds can generate off-spec sulfur for the same reasons described above for Claus and Stretford processes.

### 3.10.2.2 Generation and Management

Most off-spec sulfur from Claus units is solid with little water content. The off-spec sulfur residuals described above from the Stretford process contain varying levels of solution which would give the residual a solid, sludge, or slurry form. Some refineries report filtering this material to generate off-spec sulfur with higher solids levels.

Based on the questionnaire responses, most refineries (regardless of process) reported storing off-spec sulfur onsite in a drum, in a dumpster, or in a pile prior to its final destination. In 1992, five facilities reported classifying this residual as RCRA hazardous (a total quantity of 2,551 MT were reported), however, the hazard waste code was generally not reported.<sup>3</sup>

Sixty facilities reported generating a total quantity of almost 9,650 MT of this residual in 1992, according to the 1992 RCRA §3007 Survey. As stated in Section 3.10.1, 123 facilities reported sulfur complex/removal processes. The remaining 63 facilities either report never generating this residual, or reported generation in years other than 1992 (due to intermittent generation). There was no reason to expect that 1992 would not be a typical year with regard to this residual's generation and management. Because most of the generation quantity is concentrated at a small number of facilities using the Stretford process, however, future operational changes at those sites could greatly impact the industry-wide residual generation rate.

Residuals were assigned to be “off-spec sulfur” if they were assigned a residual identification code of “off-spec product” and were generated from a process identified as a sulfur removal or complex unit. These correspond to residual code 05 in Section VII.A of the questionnaire and process code 15 in Section IV.C of the questionnaire. Table 3.10.2 provides a description of the 1992 management practices, quantity generated, number of streams reported, number of streams not reporting volumes (data requested was unavailable and facilities were not required to generate it), total and average volumes.

---

<sup>3</sup>These percentages do not match up directly with any one of the management scenarios because the number of streams and the volume are a combination of several management scenarios (i.e., Subtitle C landfill, transfer to offsite entity, etc.).

**Table 3.10.2. Generation Statistics for Off-Spec Sulfur, 1992**

Final Management	# of Streams	# of Streams w/ Unreported Volume	Total Volume (MT)	Average Volume (MT)
Disposal in offsite Subtitle D landfill	41	10	5,043.53	123.01
Disposal in offsite Subtitle C landfill	6	2	3,575.50	510.79
Disposal in onsite Subtitle C landfill	3	0	289.07	96.36
Disposal in onsite Subtitle D landfill	10	3	225.50	22.55
Other disposal offsite (anticipated to be Subtitle C landfill)	1	0	0.10	0.10
Offsite incineration	1	0	0.70	0.70
Offsite land treatment	1	0	0.95	0.95
Other recovery onsite: sulfur plant	1	1	2.00	2.00
Transfer for use as an ingredient in products placed on the land	1	0	15.00	15.00
Transfer to other offsite entity	1	2	487.80	487.80
Transfer with coke product or other refinery product	4	0	6.52	1.63
<b>TOTAL</b>	<b>70</b>	<b>21</b>	<b>9,646.57</b>	<b>137.8</b>

### 3.10.2.3 Plausible Management

EPA believes that most of the plausible management practices for this residual were reported in the 1992 RCRA §3007 Survey, as summarized above in Table 3.10.2. No data were available to the Agency suggesting any other management practices.

### 3.10.2.4 Characterization

Two sources of residual characterization were developed during the industry study:

- Table 3.10.3 summarizes the physical and chemical properties of off-spec sulfur as reported in Section VII.A of the §3007 survey.
- Four record samples of off-spec sulfur were collected and analyzed by EPA. All of these were collected from the Claus process. Sampling information is summarized in Table 3.10.4.

The collected samples are expected to be representative of off-spec sulfur generated from Claus units, the sulfur recovery process used by most refineries. They are not expected to represent off-spec sulfur from the Stretford process because vanadium would be present in off-spec sulfur from this process at levels higher than those found in off-spec sulfur from Claus units. Concentrations of other contaminants may also differ.

All four record samples were analyzed for total and TCLP levels of volatiles, semivolatiles and metals. None of the samples were found to exhibit a hazardous waste characteristic. A summary of the analytical results is presented in Table 3.10.5. Only constituents detected in at least one sample are shown in this table.

#### 3.10.2.5 Source Reduction

During EPA's site visit, one facility was observed to generate "off-spec" sulfur product daily. Portions of the sulfur plant are being replaced with a newer design. As a result, waste sulfur residual from equipment "low points" will no longer be generated.

**Table 3.10.3. Off-Specification Sulfur: Physical Properties**

Properties	# of Values	# of Unreported Values <sup>1</sup>	10th %	50th %	90th %
pH	45	62	2.80	5.50	9.00
Reactive CN, ppm	20	87	0.00	0.25	20.85
Reactive S, ppm	35	72	0.00	1.23	92.00
Flash Point, °C	30	77	60.00	93.33	187.78
Oil and Grease, vol%	28	78	0.00	0.54	13.10
Total Organic Carbon, vol%	12	95	0.00	0.00	1.00
Vapor Pressure, mm Hg	9	98	0.00	0.10	11.00
Vapor Pressure Temperature, °C	9	98	20.00	140.00	284.00
Specific Gravity	35	72	0.80	1.36	2.07
Specific Gravity Temperature, °C	11	96	4.00	15.60	21.10
BTU Content, BTU/lb	15	92	0.00	4,606.00	4,606.00
Aqueous Liquid, %	46	61	0.00	0.00	5.00
Organic Liquid, %	44	63	0.00	0.00	100.00
Solid, %	82	25	60.00	100.00	100.00
Particle >60 mm, %	28	79	0.00	80.00	100.00
Particle 1-60 mm, %	24	83	0.00	22.50	100.00
Particle 100 µm-1 mm, %	23	84	0.00	0.00	100.00
Particle 10-100 µm, %	14	93	0.00	0.00	0.00
Particle <10 µm, %	14	93	0.00	0.00	0.00
Median Particle Diameter, microns	7	100	0.00	0.00	200.00

<sup>1</sup>Facilities were not required to do additional testing, therefore information provided was based on previously collected data or engineering judgment.

**Table 3.10.4. Off-Specification Sulfur Record Sampling Locations**

Sample number	Facility	Description
R1-SP-01	Marathon, Indianapolis, IN	Claus unit: contents of product tank destined for disposal
R2-SP-01	Shell, Wood River, IL	Claus unit: generated daily from unit "low spots"
R7B-SP-01	BP, Belle Chase, LA	Claus unit: from cleaning and turnaround of product tank
R23-SP-01	Chevron, Salt Lake City, UT	Claus unit: from loading spills, connection leaks, and sumps

**Table 3.10.5. Residual Characterization Data for Off-Specification Sulfur**

Volatile Organics - Method 8260A µg/kg								
	CAS No.	R1-SP-01	R2-SP-01	R7B-SP-01	R23-SP-01	Average Conc	Maximum Conc	Comments
Acetone	67641	< 25	< 25	< 5	2,000	514	2,000	
TCLP Volatile Organics - Methods 1311 and 8260A µg/L								
	CAS No.	R1-SP-01	R2-SP-01	R7B-SP-01	R23-SP-01	Average Conc	Maximum Conc	Comments
Acetone	67641	B 2,300	< 50	< 50	B 160	640	2,300	
Semivolatile Organics - Method 8270B µg/kg								
	CAS No.	R1-SP-01	R2-SP-01	R7B-SP-01	R23-SP-01	Average Conc	Maximum Conc	Comments
Bis(2-ethylhexyl) phthalate	117817	J 75	< 165	880	460	395	880	
Benzo(a)pyrene	50328	< 165	< 165	< 165	J 110	110	110	1
Benzo(g,h,i) perylene	191242	< 165	< 165	< 165	J 130	130	130	1
Chrysene	218019	< 165	< 165	< 165	J 270	191	270	
Di-n-butyl phthalate	84742	< 165	< 165	J 140	< 165	140	140	1
Di-n-octyl phthalate	117840	< 165	< 165	J 180	< 165	169	180	
Pyridine	110861	< 165	J 160	< 165	< 165	160	160	1
Fluorene	86737	< 165	< 165	J 280	< 165	194	280	
2-Methylchrysene	3351324	< 330	< 330	< 330	J 230	230	230	1
1-Methylnaphthalene	90120	< 330	< 330	680	< 330	418	680	
2-Methylnaphthalene	91576	< 165	< 165	760	< 165	314	760	
Phenanthrene	85018	< 165	< 165	J 140	< 165	140	140	1
TCLP Semivolatile Organics - Methods 1311 and 8270B µg/L								
	CAS No.	R1-SP-01	R2-SP-01	R7B-SP-01	R23-SP-01	Average Conc	Maximum Conc	Comments
Bis(2-ethylhexyl) phthalate	117817	< 50	J 11	< 50	< 50	11	11	1

**Table 3.10.5. Residual Characterization Data for Off-Specification Sulfur (continued)**

Total Metals - Methods 6010, 7060, 7421, 7470, 7471, and 7841 mg/kg								
	CAS No.	R1-SP-01	R2-SP-01	R7B-SP-01	R23-SP-01	Average Conc	Maximum Conc	Comments
Aluminum	7429905	< 20	< 20	780	350	293	780	
Barium	7440393	< 20	< 20	90.0	< 20	37.5	90.0	
Calcium	7440702	< 500	< 500	3,400	< 500	1,225	3,400	
Chromium	7440473	2.70	< 1.00	62.0	4.70	17.6	62.0	
Copper	7440508	< 2.50	< 2.50	68.0	8.40	20.4	68.0	
Iron	7439896	62.0	610	22,000	710	5,846	22,000	
Lead	7439921	< 0.30	0.83	4.30	3.40	2.21	4.30	
Manganese	7439965	< 1.50	< 1.50	91.0	3.20	24.3	91.0	
Molybdenum	7439987	< 6.50	< 6.50	15.0	< 6.50	8.63	15.0	
Nickel	7440020	< 4.00	< 4.00	21.0	< 4.00	8.25	21.0	
Zinc	7440666	< 2.00	< 2.00	140	34.0	44.5	140	
TCLP Metals - Methods 1311, 6010, 7060, 7421, 7470, 7471, and 7841 mg/L								
	CAS No.	R1-SP-01	R2-SP-01	R7B-SP-01	R23-SP-01	Average Conc	Maximum Conc	Comments
Aluminum	7429905	< 1.00	< 1.00	5.90	< 1.00	2.23	5.90	
Calcium	7440702	< 25.0	< 25.0	62.0	< 25.0	34.3	62.0	
Chromium	7440473	< 0.05	< 0.05	0.43	< 0.05	0.15	0.43	
Iron	7439896	< 0.50	16.0	44.0	1.50	15.5	44.0	
Manganese	7439965	< 0.08	0.26	0.77	< 0.08	0.30	0.77	
Zinc	7440666	0.31	< 0.10	B 2.90	B 0.87	1.05	2.90	

Comments:

- 1 Detection limits greater than the highest detected concentration are excluded from the calculations.

Notes:

- B Analyte also detected in the associated method blank.
- J Compound's concentration is estimated. Mass spectral data indicate the presence of a compound that meets the identification criteria for which the result is less than the laboratory detection limit, but greater than zero.

### 3.10.3 Off-Specification Treating Solution from Sulfur Complex and H<sub>2</sub>S Removal Facilities

#### 3.10.3.1 Description

All treating solutions used in refinery sulfur removal systems are regenerative, meaning the solution is used over and over in a closed system (for example, amines use multiple absorption/desorption cycles, while Stretford solution undergoes multiple reversible reactions). In the following instances the treating solution becomes “off-spec” and cannot be reused:

- **Amine systems.** At most refineries, amine continuously leaves the closed system through entrainment in overhead gas, leaks, and other routes. The amine is collected in various locations such as sumps and either returned to the process or discharged to the refinery's wastewater treatment (possibly due to purity constraints).

At some refineries, the circulating amine must be replaced in whole or in part due to contamination or process upset. Rarely, a refinery may change from one amine to another and completely remove the existing amine from the system prior to introducing the new solution.

- **Stretford systems.** Many refineries report that a portion of the circulating Stretford solution must be purged to remove impurities in the system. After purging, some refineries filter out the solids prior to further managing the spent solution. Stretford systems are used at a smaller number (15) of facilities. Unlike amine systems, Stretford solution is generally used only in tail gas treating.

During operation, the treating solution alternatively becomes “rich” (i.e., containing H<sub>2</sub>S) and “lean” (i.e., containing low levels or no H<sub>2</sub>S). In all observed cases, a refinery will generate off-spec treating solution when it is “lean.”

Approximately 800 MT of off-spec treating solution generated in 1992 was identified by 6 facilities as displaying hazardous characteristics.<sup>4</sup> The facilities designated the wastes with hazardous waste codes D002 (corrosive), D003 (reactive), D010 (TC selenium), and D018 (TC benzene). No single hazardous waste code was reported by more than one facility.

#### 3.10.3.2 Generation and Management

##### **Spent Amine Solution**

As discussed in Section 3.10.1, the amine sulfur removal process is the dominant sulfur removal process for gas streams used in the industry. Amine solutions are aqueous and are typically stored in covered sumps, tanks, etc. In the 1992 questionnaire, most facilities did not

---

<sup>4</sup>These percentages do not match up directly with any one of the management scenarios because the number of streams and the volume are a combination of several management scenarios (i.e., managed in WWTP, Subtitle C landfill, transfer for reclamation, etc.).

report how their off-spec treating solution is stored prior to final management; those that did indicated storage in a tank (most common), storage in a container, or storage in a sump.

Forty-four facilities reported generating a total quantity of 4,627 MT of spent amine in 1992, according to the 1992 RCRA §3007 Questionnaire. Residuals were assigned to be “off-spec treating solution (spent amine)” if they were assigned a residual identification code of “treating solution” and were generated from a sulfur complex or H<sub>2</sub>S removal process. These correspond to residual codes of “04-B” or “04-C” in Section VII.A and process code “15-A” and “15-D” in Section IV-1.C of the questionnaire. Based on the results of the questionnaire, approximately 123 facilities employ some type of sulfur removal system (most of these systems employ treating solution). Many facilities generate this residual on an intermittent basis, or only during unusual circumstances such as upsets. Therefore, not all of these 123 facilities are expected to generate off-spec treating solution.

Table 3.10.6 provides a description of the 1992 management practices, quantity generated, number of streams reported, number of streams not reporting volumes (data requested was unavailable and facilities were not required to generate it), total and average volumes.

**Table 3.10.6. Generation Statistics for Spent Amine for H<sub>2</sub>S Removal, 1992**

<b>Final Management</b>	<b># of Streams</b>	<b># of Streams w/ Unreported Volume</b>	<b>Total Volume (MT)</b>	<b>Average Volume (MT)</b>
Discharge to onsite wastewater treatment facility	40	16	1,224.2	30.6
Discharge to offsite privately-owned WWT facility	1	0	152	152
Disposal in onsite or offsite underground injection	4	0	673.3	168.3
Disposal in offsite Subtitle D landfill	1	0	200	200
Disposal in offsite Subtitle C landfill	1	0	39	39
Disposal in onsite surface impoundment	3	0	0.8	0.3
Neutralization	1	0	0.2	0.2
Onsite boiler	1	0	9.1	9.1
Other recovery onsite: recycle to the process	3	4	12.8	4.27
Recovery onsite in catalytic cracker	1	0	1,150	1,150
Transfer to other offsite entity/amine reclaimer	3	0	166	55.3
<b>TOTAL</b>	<b>59</b>	<b>20</b>	<b>4,627.4</b>	<b>78.4</b>



## Spent Stretford Solution

The second most frequently used process is the Stretford sulfur removal/complex process. Stretford solutions are aqueous and are typically stored in covered sumps, tanks, etc.

Twelve facilities reported generating a total quantity of 19,254.5 MT of spent Stretford solution in 1992, according to the 1992 RCRA §3007 Questionnaire. Residuals were assigned to be “spent Stretford solution” if they were assigned a residual identification code of “treating solution” and were generated from a sulfur complex or H<sub>2</sub>S removal process. These correspond to residual codes of “04-B” or “04-C” in Section VII.A and process code “15-B” and “15-E” in Section IV-1.C of the questionnaire.

Table 3.10.7 provides a description of the 1992 management practices, quantity generated, number of streams reported, number of streams not reporting volumes (data requested was unavailable and facilities were not required to generate it), total and average volumes.

**Table 3.10.7. Generation Statistics for Stretford Solution for H<sub>2</sub>S Removal, 1992**

Final Management	# of Streams	# of Streams w/ Unreported Volume	Total Volume (MT)	Average Volume (MT)
Discharge to onsite wastewater treatment facility	4	2	4,830	1,207.5
Discharge to offsite privately-owned WWT facility	3	0	6,111.5	2,037.2
Disposal in onsite Subtitle D landfill	1	0	711	711
Transfer metal catalyst for reclamation or regeneration	2	0	5,127	2563.5
Transfer of acid or caustic for reclamation, regeneration, or recovery	3	0	2,475	825
TOTAL	13	2	19,254.5	1,481

### 3.10.3.3 Plausible Management

#### Spent Amine

EPA believes that most of the plausible management practices for this residual were reported in the 1992 RCRA §3007 Survey, as summarized above in Table 3.10.6. The Agency gathered information suggesting other management practices have been used in other years including: “onsite Subtitle D landfill” (200 MT) and “offsite incineration” (120 MT). These non-1992 practices are generally comparable to practices reported in 1992 (i.e., off-site Subtitle D landfilling and on-site boiler, respectively).

## Spent Stretford Solution

EPA believes that most of the plausible management practices for this residual were reported in the 1992 RCRA §3007 Survey, as summarized above in Table 3.10.7. Even though spent Stretford solution has different properties, it is possible that the solution could be managed as the spent amine in Table 3.10.6.

### 3.10.3.4 Characterization

Two sources of residual characterization were developed during the industry study:

- Tables 3.10.8 and 3.10.9 summarize the physical properties of spent amine and spent Stretford solution as reported in Section VII.A of the §3007 survey.
- Four record samples of spent amine solution were collected and analyzed by EPA. The sample locations are summarized in Table 3.10.10.
- No samples of spent Stretford solution were available from the randomly selected facilities during record sampling.

**Table 3.10.8. Spent Amine: Physical Properties**

Properties	# of Values	# of Unreported Values <sup>1</sup>	10th %	50th %	90th %
pH	36	67	4.5	9.1	11.8
Reactive CN, ppm	5	98	0	5	12
Reactive S, ppm	10	93	1.41	280	7,500
Flash Point, °C	16	87	-10	90.6	168.9
Oil and Grease, vol%	11	92	0	0.1	1
Total Organic Carbon, vol%	16	87	0	10	15
Vapor Pressure, mm Hg	12	91	1	30	300
Vapor Pressure Temperature, °C	13	90	15	25	50
Viscosity, lb/ft-sec	10	93	0	0	10
Specific Gravity	34	69	1	1.1	1.1
Specific Gravity Temperature, °C	16	87	15	17.5	38
Aqueous Liquid, %	61	42	0	100	100
Organic Liquid, %	43	60	0	0	100
Solid, %	36	67	0	0	20

<sup>1</sup>Facilities were not required to do additional testing, therefore information provided was based on previously collected data or engineering judgment.

**Table 3.10.9. Spent Stretford Solution: Physical Properties**

Properties	# of Values	# of Unreported Values <sup>1</sup>	10th %	50th %	90th %
pH	10	12	8.3	8.8	9.7
Reactive CN, ppm	2	19	1	1.35	1.7
Reactive S, ppm	2	19	0.1	3,190	6,380
Oil and Grease, vol%	1	20	1	1	1
Total Organic Carbon, vol%	4	17	0	0	1
Vapor Pressure, mm Hg	3	18	1.5	10	20
Specific Gravity	8	14	1	1.1	1.5
COD, mg/L	4	17	100	6,930	6,930
Aqueous Liquid, %	9	13	0	90	100
Organic Liquid, %	3	19	0	0	0
Solid, %	10	12	0.5	10	100

<sup>1</sup>Facilities were not required to do additional testing, therefore information provided was based on previously collected data or engineering judgment.

**Table 3.10.10. Off-Specification Treating Solution Record Sampling Locations**

Sample Number	Facility	Description
R11-SA-01	ARCO, Ferndale, WA	Refinery DEA system: circulating amine
R13-SA-01	Shell, Deer Park, TX	Refinery DEA system: circulating amine
R14-SA-01	BP, Toledo, OH	Refinery DEA system: from sump collecting knock-out pot liquid, etc, prior to its exiting the system
R15-SA-01	Total, Ardmore, OK	Refinery MDEA system: circulating amine

All of the samples were taken from refinery amine systems and are believed to represent the various types of spent amine generated by refineries. No samples from the tail gas system units were collected. Tail gas residuals are expected to be cleaner because the feeds are cleaner. Therefore, the tail gas treating residuals are expected to exhibit levels of contaminants no higher than those found in the sampled residuals. No samples of Stretford solution were taken. Stretford systems were not used by the facilities randomly selected by the Agency for record sampling. Samples of Stretford solution are expected to exhibit higher levels of vanadium than amine solution because vanadium is present in new Stretford solution; levels of some organic contaminants may be lower because most refineries use their Stretford system to treat low-organic Claus unit tail gas.

Several of the samples were taken from the process line (i.e., at the time of sampling, the refinery had no immediate plans to remove the sampled treating solution from the system).

However, these refineries indicated they do remove all or part of their circulating amine on an infrequent basis due to process upset or excessive contaminant levels. The sampled amine is expected to have contaminant concentrations at least as high as when the circulating amine is removed from the system. Physical properties such as pH and flash point are expected to be similar as well.

All four samples were analyzed for total and TCLP levels of volatiles, semivolatiles, and metals, pH, total amines, and ignitability. Two samples were also analyzed for reactive sulfides. One sample exhibited the characteristic of ignitability. A summary of the results is presented in Table 3.10.11. Only constituents detected in at least one sample are shown in this table.

### 3.10.3.5 Source Reduction

Source reduction of amine involves modifying the process. During the site visits, information was gathered that several facilities capture the amine for recycling. Two facilities replaced the cloth filter at the sulfur recovery unit with an etched metal mechanical filter. The new filter requires less maintenance, and also eliminates amine discharges to the wastewater treatment plant due to filter change-outs. Another two facilities have installed sumps at the sulfur complex. The sumps capture amine that is drained from the filters during bag change-outs and recycle it to the amine system. Without the sumps, the amine drained from the filters is discharged to the wastewater treatment plant.

Reference	Waste Minimization/Management Methods
Stewart, E.J. and Lanning, R.A. "Reduce Amine Plant Solvent Losses, Part 2." <i>Hydrocarbon Processing</i> . June, 1994.	Process modification.
"Liquid Catalyst Efficiently Removes H <sub>2</sub> S From Liquid Sulfur." <i>Oil &amp; Gas Journal</i> . July 17, 1989.	Lower catalyst quantities needed to remove H <sub>2</sub> S in the sulfur degassing process.
Stewart, E.J. and Lanning, R.A. "Reduce Amine Plant Solvent Losses, Part 1." <i>Hydrocarbon Processing</i> . May, 1994.	Process modification.

**Table 3.10.11. Characterization Data for Off-Specification Treating Solution from Sulfur Complex and H<sub>2</sub>S Removal**

Petroleum Refining Industry Study

145

Volatile Organics - Method 8260A µg/L										
	CAS No.	R11-SA-01	R13-SA-01	R14-SA-01	R15-SA-01	Average Conc	Maximum Conc	Comments		
Acetone	67641	< 25	< 50	< 25	10	10	10	1		
Benzene	71432	< 25	< 50	88	< 5	42	88			
Toluene	108883	< 25	< 50	220	< 5	75	220			
o-Xylene	95476	< 25	< 50	J 24	< 5	15	24	1		
m,p-Xylenes	108383 / 106423	< 25	< 50	69	< 5	37	69			
Naphthalene	91203	< 25	< 50	J 32	< 5	19	32	1		
Semivolatile Organics - Method 8270B µg/L										
	CAS No.	R11-SA-01	R13-SA-01	R14-SA-01	R15-SA-01	Average Conc	Maximum Conc	Comments		
Acenaphthene	83329	< 50	< 545	180	< 575	115	180	1		
Anthracene	120127	J 18	< 545	250	< 575	134	250	1		
Aniline	62553	< 50	J 540	< 50	< 575	213	540	1		
Benz(a)anthracene	56553	< 50	< 545	J 34	< 575	34	34	1		
Bis(2-ethylhexyl)phthalate	117817	JB 26	< 545	J 17	< 575	22	26	1		
Carbazole	86748	J 80	< 1,090	< 100	< 1,150	80	80	1		
Chrysene	218019	< 50	< 545	J 71	< 575	61	71	1		
Dibenzofuran	132649	< 50	< 545	160	< 575	105	160	1		
2,4-Dimethylphenol	105679	110	< 545	J 86	< 575	98	110	1		
Fluoranthene	206440	J 17	< 545	< 50	< 575	17	17	1		
Fluorene	86737	< 50	< 545	1,100	< 575	568	1,100			
2-Methylchrysene	3351324	< 100	< 1,090	J 84	< 1,150	84	84	1		
1-Methylnaphthalene	90120	< 100	< 1,090	2,500	< 1,150	1,210	2,500			
2-Methylnaphthalene	91576	< 50	< 545	3,400	< 575	1,143	3,400			
2-Methylphenol	95487	360	< 545	210	< 575	285	360	1		
3/4-Methylphenol	NA	1,200	< 545	1,000	< 575	830	1,200			
Phenanthrene		J 50	< 545	3,000	< 575	1,043	3,000			
Phenol	108952	4,400	< 545	3,100	< 575	2,155	4,400			
Pyrene		J 25	< 545	430	< 575	228	430	1		
1-Naphthylamine	134327	< 50	< 545	< 50	J 230	110	230	1		
Naphthalene	91203	< 50	< 545	150	< 575	100	150	1		

August 1996

**Table 3.10.11. Characterization Data for Off-Specification Treating Solution from Sulfur Complex and H<sub>2</sub>S Removal (continued)**

Total Metals - Methods 6010, 7060, 7421, 7470, 7471, and 7841 mg/L								
	CAS No.	R11-SA-01	R13-SA-01	R14-SA-01	R15-SA-01	Average Conc	Maximum Conc	Comments
Aluminum	7429905	0.39	< 0.10	< 0.10	< 0.10	0.17	0.39	
Antimony	7440360	0.81	< 0.03	< 0.03	0.62	0.37	0.81	
Cadmium	7440439	0.035	< 0.003	< 0.003	0.025	0.016	0.035	
Chromium	7440473	0.26	0.99	0.021	0.031	0.326	0.990	
Cobalt	7440484	0.11	< 0.025	< 0.025	0.099	0.065	0.110	
Copper	7440508	< 0.013	< 0.013	0.034	< 0.013	0.018	0.034	
Iron	7439896	39.0	14.0	1.10	0.11	13.6	39.0	
Manganese	7439965	0.31	2.30	0.043	< 0.008	0.67	2.30	
Potassium	7440097	21.0	< 2.50	< 2.50	22.0	12.0	22.0	
Selenium	7782492	0.031	0.61	0.038	0.99	0.42	0.99	
Sodium	7440235	8.40	< 2.50	< 2.50	2,300	578	2,300	
Zinc	7440666	< 0.01	< 0.01	0.039	< 0.01	0.017	0.039	
Miscellaneous Characterization								
		R11-SA-01	R13-SA-01	R14-SA-01	R15-SA-01	Average Conc	Maximum Conc	Comments
Ignitability (oF)		> 211	NA	> 210	90	NA	NA	
Corrosivity (pH units)		10	10	8.9	11.5	NA	NA	
Reactivity - Total ReleasableH <sub>2</sub> S (mg/L)		< 20	NA	48	NA	NA	NA	
Amines - Methyl-diethanolamine (mg/L)		ND	ND	ND	36,000	36,000	36,000	
Amines - Ethanolamine (mg/L)		4,400	4,500	ND	ND	4,450	4,500	
Amines - Diethanolamine (mg/L)		330,000	280,000	41,300	ND	217,100	330,000	

Comments:

- 1 Detection limits greater than the highest detected concentration are excluded from the calculations. TCLP was not performed because these were liquid samples

Notes:

- B Analyte also detected in the associated method blank.
- J Compound's concentration is estimated. Mass spectral data indicate the presence of a compound that meets the identification criteria for which the result is less than the laboratory detection limit, but greater than zero.
- ND Not Detected.
- NA Not Applicable.

### 3.11 CLAY FILTERING

Clay belongs to a broad class of materials designed to remove impurities via adsorption. Examples of clay include Fullers earth, natural clay, and acid treated clay. However, similar materials such as bauxite are also available and used to impart similar qualities to the product. In addition, materials such as sand, salt, molecular sieve, and activated carbon are used for removing impurities by adsorption or other physical mechanisms. All solid materials discussed in Section 3.11.1 are termed as “solid sorbents” for the purposes of defining this residual category.

#### 3.11.1 Process Description

Clay or other adsorbents are used to remove impurities from many hydrocarbon streams. Some of these applications are associated with isomerization, extraction, alkylation, and lube oil processing; such processes are discussed in the respective sections of this document. Other solid media remove impurities from amine solutions used in hydrogen sulfide removal systems; such media were discussed in the *Listing Background Document*. Solid media used in all other refinery processes are summarized and discussed in this section. The principal applications are described below.

**Kerosene Clay Filtering:** Clay treatment removes diolefins, asphaltic materials, resins, and acids; this improves the color of the product and removes gum-forming impurities (Speight, 1991). The RCRA §3007 Survey indicates that approximately 90 facilities use this process; some facilities have multiple treaters or treat different streams, so that an estimated 150 processes exist. Most clay treatment is conducted as a fixed bed. A typical clay volume is 2,000 ft<sup>3</sup>, distributed in 1 or more vessels. Alternatively to the fixed bed process, the clay can be mixed with the hydrocarbon and filtered in a belt press. In addition to kerosene, some facilities identify filtering furnace oils through clay and generating spent clay in a similar manner.

**Catalyst Support in Merox and Minalk Systems:** The Merox and Minalk caustic treatment systems convert mercaptans to disulfides using oxygen and an organometallic catalyst in an alkaline environment. Depending on the process configuration, the disulfides can remain in the hydrocarbon product (a “sweetening” process) or the disulfides can be removed by settling (an “extractive” process). These treatment processes are commonly applied to gasoline, but refinery streams ranging from propane to diesel undergo this treatment.

The catalyst can either be dissolved in the caustic or can be supported on a fixed bed. Either activated carbon, coal, or charcoal are typically used as support material for solid supported catalyst (the hydrocarbon passes over the catalyst, where reaction occurs). These materials provide contact area for reaction when the catalyst is dissolved in the caustic. The RCRA §3007 survey indicates that approximately 25 facilities (using 40 processes) reported generating spent carbon, coal, or charcoal from these processes; additional facilities likely generate this residual but did not report generation in the questionnaire because the residual is typically generated infrequently.

**Drying:** Water is removed from many hydrocarbon streams ranging from diesel fuel to propane. Water must be removed for reasons including: (1) product specifications (e.g., jet fuel

has low tolerances for water content), and (2) reactor feed preparation (e.g., precious metal catalysts are often poisoned by water). Salt and sand are commonly used for the first application, while molecular sieve is commonly used for the second application.

When hydrocarbon is passed through a fixed bed of sand, the moisture collects on the sand particles and eventually settles to the bottom of the vessel, where the water is removed. In a salt drier, water in the stream dissolves salt (e.g., sodium chloride) which then collects in the vessel bottom and is periodically removed. As a result, the vessel requires periodic topping with solid salt.

Salt and sand treaters can be found throughout the refinery to treat hydrocarbons ranging from diesel to propane. They are commonly found following aqueous treatments such as caustic washing, water washing, or Merox caustic treatment. In these treatments, the hydrocarbon is contacted with the aqueous stream; the hydrocarbon then passes through salt or sand to remove residual moisture. The RCRA §3007 questionnaire indicates that approximately 60 facilities (using 150 processes) reported generating spent salt or sand from these processes; additional facilities likely generate this residual but did not report generation in the questionnaire because it was not generated in 1992.

Molecular sieves are most commonly used to selectively adsorb water and sulfur compounds from light hydrocarbon fractions such as propane and propylene. The hydrocarbon passes through a fixed bed of molecular sieve. After the bed is saturated, water is desorbed by passing heated fuel gas over the bed to release the adsorbed water and sulfur compounds into the regeneration gas stream, which is commonly sent to a flare stack. Molecular sieves are often used for drying feed to the isomerization unit and HF acid alkylation unit, applications that are discussed in Sections 3.4 and 3.5, respectively, of this document. Other applications include drying propane or propylene prior to entering the Dimersol unit, drying naphtha entering the reformer, and feed preparation for other reaction units. Molecular sieves are also used to dry light-end product streams from the hydrocracker, catalytic reformer, and light-ends recovery unit. Less common uses also exist for molecular sieves including the separation of light-end fractions such as methanol, butane, and butylene. In total, the RCRA §3007 questionnaire indicates that approximately 70 facilities (using 150 processes) reported generating spent molecular sieve; this includes the applications of HF acid alkylation and isomerization that are discussed elsewhere in this document, but excludes additional facilities that are likely generate this residual but did not report 1992 generation in the questionnaire.

**Sulfur and Chloride Guards in Catalytic Reforming:** As discussed in the *Listing Background Document*, catalytic reforming units require a platinum catalyst; this catalyst is readily poisoned by sulfur compounds. To prolong catalyst life, many refineries install sulfur traps to remove sulfur compounds prior to the reforming catalyst bed. This material can consist of granular or pelletized metal oxides, such as copper or magnesium. These materials (1) remove H<sub>2</sub>S, (2) convert mercaptans to H<sub>2</sub>S and organic sulfides, and (3) remove generated H<sub>2</sub>S. The material can be desorbed, reactivated, and reused (Perry's, 1950). Alumina also is used to treat light naphtha prior to isomerization (which also uses precious metal catalyst). The RCRA §3007 questionnaire indicates that approximately 20 facilities reported generating spent sulfur guards from 35 applications, most often as guards for reforming and isomerization reactors.



Additional facilities may employ sulfur guards but did not report generation in the questionnaire because the residual is typically generated infrequently.

Alumina beds may be used to remove chlorides from the hydrogen produced from the reforming process. The hydrogen is then used throughout the refinery. The alumina bed is expected to last for 24-30 months prior to chloride breakthrough, when replacement of the alumina is required. Reformate from the reformer may also be passed through alumina to remove chloride. The RCRA §3007 questionnaire indicates that approximately 15 facilities reported generating spent chloride guards from 25 applications, most often in the reforming process.

**Propane Treating by Alumina:** An activated alumina bed is used to de-fluorinate propane generated from a propane stripper. The propane then is dried in a sand tower and a drier which also contains alumina. Both the defluorinator and drier periodically generate spent alumina.

**Particulate Filters:** Entrained solids can be removed by in-line cartridge filters. These cartridges are commonly used for finishing kerosene, diesel fuel, etc., prior to sale. Approximately 10 facilities reported generating spent cartridges from 20 applications, according to the questionnaire results.

In most of the applications discussed above, the use of solid media such as clay, sand, etc. are not the only options refineries have in imparting the desired properties on a product. For example, drying can be conducted by simple distillation. Hydrotreating and caustic treating are common alternatives to the clay treatment of jet fuel by removing undesirable contaminants from the kerosene/jet fuel fraction. And, as discussed above, the Merox process can be conducted with or without solid supported catalyst.

### **3.11.2 Treating Clay from Clay Filtering**

#### **3.11.2.1 Description**

Generated at many places in the refinery, spent solid sorbents have liquid contents ranging from very low (e.g., for molecular sieves treating light hydrocarbons) to oil-saturated material (e.g., for clay used for treating kerosene). The substrate is either inorganic (such as alumina, zeolite, or clay) or organic (such as activated carbon). Most applications are fixed bed, where the material is charged to vessels and the hydrocarbon passed through the fixed bed of solid sorption media. The fixed bed can remain in service for a period of time ranging from several months to 10 years, depending on the application. At the end of service, the vessel is opened, the “spent” material removed, and the vessel recharged.

### 3.11.2.2 Generation and Management

The spent clay is vacuumed or gravity dumped from the vessels into piles or into containers such as drums and roll-off bins. The RCRA §3007 questionnaire and site visits indicate that very few other interim storage methods are used.

In 1992, approximately 30 facilities reported that 1,700 MT of this residual was managed as hazardous. The most commonly designated waste codes were D001 (ignitable), D008 (TC lead), and D018 (TC benzene).<sup>5</sup> This is consistent with how the residual was reported to be managed in other years.

One hundred facilities reported generating a total quantity of approximately 9,000 MT of this residual in 1992, according to the 1992 RCRA §3007 Questionnaire. There was no reason to expect that 1992 would not be a typical year with regard to this residual's generation and management. Residuals were assigned to be "treating clay from clay filtering" if they were assigned a residual identification code of "spent sorbent" (residual coded "07") and were **not** generated from a process identified as an alkylation, isomerization, extraction, sulfur removal, or lube oil unit (process codes "09," "10," "12," "15," and "17," respectively) (sorbents from these units are discussed elsewhere in this document or in the *Listing Background Document*). The frequency of generation is highly variable as discussed in Section 3.11.1. Table 3.11.1 provides a description of the 1992 management practices, quantity generated, number of streams reported, number of streams not reporting volumes (data requested was unavailable and facilities were not required to generate it), total and average volumes.

The wide array of management methods reflect the numerous applications of sorbents. For example, disposed salt from salt driers can be managed in onsite wastewater treatment plants, cement plants can accept spent alumina, and catalyst reclaimers can accept sulfur sorbers having recoverable metals. The large quantity disposed, however, demonstrates that for most applications and refineries the spent clay is seen as a low value solid waste.

### 3.11.2.3 Plausible Management

EPA believes that most of the plausible management practices for this residual were reported in the 1992 RCRA §3007 Survey, as summarized above in Table 3.11.1. The Agency gathered information suggesting other management practices have been used in other years including: "other recycling, reclamation, or reuse: unknown" (1 MT), "other recycling, reclamation, or reuse: onsite road material" (13.5 MT) and "reuse as a replacement catalyst for another unit" (5 MT). These non-1992 very small management practices are comparable to the recycling practices reported in 1992.

---

<sup>5</sup>These percentages do not match up directly with any one of the management scenarios because the number of streams and the volume are a combination of several management scenarios (i.e., managed in WWTP, Subtitle C landfill, transfer as a fuel, etc.).

**Table 3.11.1. Generation Statistics for Treating Clay from Clay Filtering, 1992**

<b>Final Management</b>	<b># of Streams</b>	<b># of Streams w/ Unreported Volume</b>	<b>Total Volume (MT)</b>	<b>Average Volume (MT)</b>
Discharge to onsite wastewater treatment facility	14	3	514	36.7
Disposal in offsite Subtitle D landfill	91	0	3,642.1	40
Disposal in offsite Subtitle C landfill	42	0	1,735	41.3
Disposal in onsite Subtitle C landfill	1	1	52.4	52.4
Disposal in onsite Subtitle D landfill	15	0	1,031.9	68.8
Evaporation	1	0	7.9	7.9
Offsite incineration	7	0	42.1	6
Offsite land treatment	9	0	198.3	22
Onsite land treatment	16	0	923.1	57.7
Other disposal onsite: bioremediation, fill material, or onsite berms	5	0	57.4	11.5
Other recovery onsite: recycle to process	1	0	20.1	20.1
Other recycling, reclamation, or reuse: cement plant	5	0	161.4	32.3
Offsite filter recycling	2	0	38	19
Storage in pile	2	0	128	64
Recovery in coker	1	0	20	20
Transfer for direct use as a fuel or to make a fuel	1	0	95	95
Transfer for use as an ingredient in products placed on the land	6	0	175.8	29.3
Transfer metal catalyst for reclamation or regeneration	10	0	89.4	8.9
Transfer to other offsite entity/carbon regeneration	2	0	53.6	26.8
Transfer with coke product or other refinery product	1	0	4.5	4.5
<b>TOTAL</b>	<b>232</b>	<b>4</b>	<b>8,990</b>	<b>38.8</b>

#### 3.11.2.4 Characterization

Two sources of residual characterization were developed during the industry study:

- Table 3.11.2 summarizes the physical properties of the spent clay as reported in Section VII.A of the §3007 survey.
- Four record samples of spent clay were collected and analyzed by EPA. These spent clays represent some of the various types of applications used by the industry. Sampling information is summarized in Table 3.11.3.

**Table 3.11.2. Treating Clay from Clay Filtering: Physical Properties**

Properties	# of Values	# of Unreported Values <sup>1</sup>	10th %	50th %	90th %
pH	171	334	4.6	7.6	10.4
Reactive CN, ppm	100	405	0	0.5	50
Reactive S, ppm	106	399	0	10	125
Flash Point, °C	132	373	57.2	93.3	200
Oil and Grease, vol%	94	411	0	1	17.5
Total Organic Carbon, vol%	50	455	0	1	55
Specific Gravity	167	338	0.7	1.3	2.6
Specific Gravity Temperature, °C	50	455	15	20	25
BTU Content, BTU/lb	31	474	0	2,000	13,500
Aqueous Liquid, %	230	275	0	0	10.3
Organic Liquid, %	240	265	0	0	5
Solid, %	346	159	89.0	100	100
Particle >60 mm, %	59	446	0	0	100
Particle 1-60 mm, %	91	414	0	100	100
Particle 100 µm-1 mm, %	70	435	0	10	100
Particle 10-100 µm, %	54	451	0	0	20
Particle <10 µm, %	49	456	0	0	0
Median Particle Diameter, microns	48	457	0	1,000	3,000

<sup>1</sup>Facilities were not required to do additional testing, therefore information provided was based on previously collected data or engineering judgment.

**Table 3.11.3. Treating Clay Record Sampling Locations**

Sample #	Facility	Description
R1-CF-01	Marathon Indianapolis, IN	kerosene/jet treating clay (fixed bed process)
R6-CF-01	Shell Norco, LA	kerosene/jet treating clay (bag filter process, generated daily)
R11-CF-01	ARCO Ferndale, WA	reformer unit sulfur trap
R23-CF-01	Chevron, Salt Lake City, UT	kerosene/jet treating clay

The collected samples are expected to be representative of treating clay from kerosene treatment. Section 3.11.1 shows that kerosene clay treatment represents the highest single use of sorbents in refineries (outside of the sulfur recovery, isomerization, and alkylation processes that are not included in the scope of this study residual). In addition, a cursory review of the 1992 generation data presented in Section 3.11.2.2 shows that the 1992 generation rate of spent kerosene treating clay represents at least half of the total 1992 quantity from all sources identified in Section 3.11.1.

One of the samples is representative of a sulfur guard bed. Other applications of spent sorbents (discussed in Section 3.11.1) are not well represented by the record sampling. Specifically:

- Spent activated carbon from Merox treatment, salt and sand from product drying, particulate filters, and chloride removal beds are not expected to resemble these materials.
- Spent molecular sieves and alumina are not represented by the collected record samples. However, they may be represented by the record samples of isomerization treating clay and alkylation treating clay, discussed in Sections 3.4 and 3.5, respectively.

All four record samples were analyzed for total and TCLP levels of volatiles, semivolatiles, and metals. Two samples were analyzed for ignitability and all were analyzed for reactivity (pyrophoricity). One of the samples was found to exhibit the ignitability characteristic. High manganese concentrations in one sample result from the adsorbent make-up. A summary of the results is presented in Table 3.11.4. Only constituents detected in at least one sample are shown in this table.

#### 3.11.2.5 Source Reduction

One facility reported that its jet fuel treating clay is regenerated once by back-washing the clay bed with jet fuel to “fluff” the clay and alleviate the pressure drop.

**Table 3.11.4. Residual Characterization Data for Treating Clay**

Petroleum Refining Industry Study

154

August 1996

Volatile Organics - Method 8260A µg/kg									
	CAS No.	R1-CF-01	R6-CF-01	R11-CF-01	R23-CF-01	Average Conc	Maximum Conc	Comments	
Acetone	67641	260,000	< 565	< 25	< 1,250	65,460	260,000		
Benzene	71432	< 125,000	8,500	540	< 1,250	3,430	8,500	1	
n-Butylbenzene	104518	< 125,000	94,000	< 25	< 1,250	31,758	94,000	1	
sec-Butylbenzene	135988	< 125,000	54,000	< 25	< 1,250	18,425	54,000	1	
Ethylbenzene	100414	< 125,000	76,000	J 28	2,800	26,276	76,000	1	
Isopropylbenzene	98828	< 125,000	44,000	< 25	< 1,250	15,092	44,000	1	
p-Isopropyltoluene	99876	< 125,000	59,000	< 25	< 1,250	20,092	59,000	1	
n-Propylbenzene	103651	< 125,000	70,000	< 25	< 1,250	23,758	70,000	1	
Methylene chloride	75092	< 125,000	< 565	100	< 1,250	100	100	1	
Toluene	108883	< 125,000	140,000	340	3,600	67,235	140,000		
1,2,4-Trimethylbenzene	95636	580,000	620,000	< 25	32,000	308,006	620,000		
1,3,5-Trimethylbenzene	108678	< 125,000	210,000	< 25	13,000	87,006	210,000		
o-Xylene	95476	< 125,000	180,000	89	7,200	78,072	180,000		
m,p-Xylenes	108383 / 106423	300,000	380,000	130	23,000	175,783	380,000		
Naphthalene	91203	310,000	350,000	< 25	9,800	167,456	350,000		
TCLP Volatile Organics - Methods 1311 and 8260A µg/L									
	CAS No.	R1-CF-01	R6-CF-01	R11-CF-01	R23-CF-01	Average Conc	Maximum Conc	Comments	
Acetone	67641	43,000	< 50	< 50	B 100	10,800	43,000		
Benzene	71432	< 1,250	100	J 44	< 50	65	100	1	
Ethylbenzene	100414	< 1,250	190	< 50	< 50	97	190	1	
Methylene chloride	75092	2,600	< 50	1,700	< 50	1,100	2,600		
Toluene	108883	< 1,250	850	210	< 50	370	850	1	
1,2,4-Trimethylbenzene	95636	4,900	840	< 50	J 62	1,463	4,900		
1,3,5-Trimethylbenzene	108678	< 1,250	270	< 50	< 50	123	270	1	
o-Xylene	95476	< 1,250	610	< 50	J 44	235	610	1	
m,p-Xylene	108383 / 106423	< 1,250	1,200	< 50	110	453	1,200	1	
Naphthalene	91203	< 1,250	650	< 50	J 71	257	650	1	
Semivolatile Organics - Method 8270B µg/kg									
	CAS No.	R1-CF-01	R6-CF-01	R11-CF-01	R23-CF-01	Average Conc	Maximum Conc	Comments	
Bis(2-ethylhexyl) phthalate	117817	< 6,600	< 4,125	J 100	< 4,150	100	100	1	
Carbazole	86748	< 13,200	< 8,250	< 330	J 6,000	3,165	6,000	1	
Di-n-butyl phthalate	57976	< 6,600	< 4,125	420	< 4,150	420	420	1	
Dibenzofuran	132649	< 6,600	J 24,000	< 165	< 4,150	8,729	24,000		
Fluorene	86737	< 6,600	< 4,125	< 165	20,000	7,723	20,000		
2,4-Dimethylphenol	105679	< 6,600	< 4,125	2,500	< 4,150	2,500	2,500	1	

**Table 3.11.4. Residual Characterization Data for Treating Clay (continued)**

Semivolatile Organics - Method 8270B µg/kg (continued)									
	CAS No.	R1-CF-01	R6-CF-01	R11-CF-01	R23-CF-01	Average Conc	Maximum Conc	Comments	
2-Methylphenol	95487	< 6,600	< 4,125	9,000	< 4,150	5,969	9,000		
3/4-Methylphenol	NA	< 6,600	< 4,125	30,000	< 4,150	11,219	30,000		
1-Methylnaphthalene	90120	980,000	890,000	< 165	78,000	487,041	980,000		
2-Methylnaphthalene	91576	150,000	1,200,000	< 165	92,000	360,541	1,200,000		
Naphthalene	91203	120,000	740,000	< 165	43,000	225,791	740,000		
Phenanthrene	85018	< 6,600	J 4,800	< 165	25,000	9,141	25,000		
Phenol	108952	< 6,600	< 4,125	20,000	< 4,150	8,719	20,000		
TCLP Semivolatile Organics - Methods 1311 and 8270B µg/L									
	CAS No.	R1-CF-01	R6-CF-01	R11-CF-01	R23-CF-01	Average Conc	Maximum Conc	Comments	
Bis(2-ethylhexyl) phthalate	117817	290	J 16	< 250	< 50	152	290		
Dibenzofuran	132649	< 50	J 17	< 250	< 50	17	17	1	
Di-n-butyl phthalate	84742	< 50	JB 19	< 250	< 50	19	19	1	
2,4-Dimethylphenol	105679	350	J 73	1,400	< 50	468	1,400		
Fluorene	86737	< 50	J 41	< 250	< 50	41	41	1	
1-Methylnaphthalene	90120	J 190	550	< 250	J 130	280	550		
2-Methylnaphthalene	91576	220	780	< 500	120	405	780		
Naphthalene	91203	600	700	< 250	140	423	700		
2-Methylphenol	95487	310	< 50	7,800	< 50	2,053	7,800		
3/4-Methylphenol (total)	NA	580	< 50	6,300	< 50	1,745	6,300		
Phenol	108952	< 50	< 50	2,300	< 50	613	2,300		
Total Metals - Methods 6010, 7060, 7421, 7470, 7471, and 7841 mg/kg									
	CAS No.	R1-CF-01	R6-CF-01	R11-CF-01	R23-CF-01	Average Conc	Maximum Conc	Comments	
Aluminum	7429905	12,000	6,800	110,000	13,000	35,450	110,000		
Arsenic	7440382	3.20	< 1.00	14.0	16.0	8.55	16.0		
Barium	7440393	78.0	< 20.0	< 20.0	59.0	44.3	78.0		
Beryllium	7440417	3.80	< 0.50	< 0.50	2.50	1.83	3.80		
Calcium	7440702	4,500	16,000	< 500	4,400	6,350	16,000		
Chromium	7440473	37.0	24.0	34.0	39.0	33.5	39.0		
Cobalt	7440484	12.0	< 5.00	34.0	11.0	15.5	34.0		
Copper	7440508	< 2.50	< 2.50	5.30	620	158	620		
Iron	7439896	9,400	3,800	97.0	9,800	5,774	9,800		
Lead	7439921	4.80	1.90	2.70	6.00	3.85	6.00		
Magnesium	7439954	9,400	10,000	< 500	9,300	7,300	10,000		
Manganese	7439965	130	140	150,000	120	37,598	150,000		
Mercury	7439976	< 0.05	< 0.05	< 0.05	0.26	0.10	0.26		

**Table 3.11.4. Residual Characterization Data for Treating Clay (continued)**

Total Metals - Methods 6010, 7060, 7421, 7470, 7471, and 7841 mg/kg (continued)								
	CAS No.	R1-CF-01	R6-CF-01	R11-CF-01	R23-CF-01	Average Conc	Maximum Conc	Comments
Molybdenum	7439987	< 6.50	< 6.50	14.0	< 6.50	8.38	14.0	
Nickel	7440020	16.0	< 4.00	< 4.00	31.0	13.8	31.0	
Potassium	7440097	1,400	< 500	< 500	1,300	925	1,400	
Selenium	7782492	< 0.50	< 0.50	22.0	< 0.50	5.88	22.0	
Silver	7440224	< 1.00	< 1.00	70.0	< 1.00	18.3	70.0	
Sodium	7440235	34,000	< 500	< 500	< 500	8,875	34,000	
Vanadium	7440622	37.0	21.0	34.0	35.0	31.8	37.0	
Zinc	7440666	47.0	19.0	< 2.00	55.0	30.8	55.0	
TCLP Metals - Methods 1311, 6010, 7060, 7421, 7470, 7471, and 7841 mg/L								
	CAS No.	R1-CF-01	R6-CF-01	R11-CF-01	R23-CF-01	Average Conc	Maximum Conc	Comments
Aluminum	7429905	< 1.00	< 1.00	< 1.00	3.90	1.73	3.90	
Arsenic	7440382	< 0.05	< 0.05	< 0.05	0.13	0.07	0.13	
Calcium	7440702	54	590	< 25.0	60.0	182	590	
Copper	7440508	< 0.13	< 0.13	< 0.13	0.89	0.32	0.89	
Iron	7439896	< 0.50	< 0.50	< 0.50	1.00	0.63	1.00	
Magnesium	7439954	< 25.0	91	< 25.0	< 25.0	41.5	91.0	
Manganese	7439965	< 0.08	2.60	1,400	0.85	351	1,400	
Silver	7440224	< 0.05	< 0.05	0.10	< 0.05	0.06	0.10	
Zinc	7440666	< 0.10	B 0.76	< 0.10	B 0.27	0.31	0.76	
Miscellaneous Characterization								
		R1-CF-01	R6-CF-01	R11-CF-01	R23-CF-01	Average Conc	Maximum Conc	Comments
Ignitability (oF)		185	131	NA	NA	NA	NA	

Comments:

- 1 Detection limits greater than the highest detected concentration are excluded from the calculations.

Notes:

- B Analyte also detected in the associated method blank.
- J Compound's concentration is estimated. Mass spectral data indicate the presence of a compound that meets the identification criteria for which the result is less than the laboratory detection limit, but greater than zero.
- ND Not Detected.
- NA Not Applicable.



### 3.12 RESIDUAL OIL TANK STORAGE

Almost every refinery stores its feed and products in tanks onsite. Occasionally (every 10 to 20 years), tanks require sediment removal due to maintenance, inspection, or sediment buildup. These tank bottoms are removed by techniques ranging from manual shoveling to robotics and filtration. Residual oil tank sludge is a study residual of concern.

Residual oil is generally considered to be equivalent to No. 6 fuel oil which is a heavy residue oil sometimes called Bunker C when used to fuel ocean-going vessels. Preheating is required for both handling and burning. It is typically produced from units such as atmospheric and vacuum distillation, hydrocracking, delayed coking, and visbreaking. The fluid catalytic cracking unit also contributes to the refinery's heavy oil pool, but EPA terms this material "clarified slurry oil," or CSO, and discussed this product separately in the *Listing Background Document* (October 31, 1995).

According to DOE's *Petroleum Supply Annual*, approximately 400 million barrels of "residual oil" was domestically used in 1992 (including imports and exports). The use profile in 1994 was as follows (DOE's *Fuel Oil and Kerosene Sales 1994*):

<u>Sector</u>	<u>1990 Consumption of Residual Fuel Oil</u>
Electric Utility	40%
Shipping	35%
Industrial	15%
Commercial and Other	10%

The larger utilities often have their own specifications when purchasing residual fuel oil. These can include sulfur, nitrogen, ash, and vanadium. The current ASTM standard for No. 6 oil (D-396) specifies only three parameters: minimum flash point (of 150°F), maximum water and sediment (of 2 percent), and a viscosity range (Bonnet, 1994). Thus, the characteristics of residual oil, and the generated tank sludge, can vary greatly depending on the buyer and the refinery.

#### 3.12.1 Residual Oil Storage Tank Sludge

In 1992, 125 U.S. refineries reported approximately 717 residual oil storage tanks. From the survey, tank volume was reported for about 10 percent (73) of these tanks (excluding outliers); the average tank volume was approximately 77,000 barrels. DOE's *Petroleum Supply Annual 1992* reported that refineries produced about 327 million barrels of No. 6 fuel oil or residual oil or approximately 900,000 barrels per day (this likely includes CSO).

##### 3.12.1.1 Description

Residual oil tank sludge consists of heavy hydrocarbons, rust and scale from process pipes and reactors, and entrapped oil that settles to the bottom of the tank. It can be manually removed directly from the tank after drainage of the residual oil or, commonly, removed using a variety of oil recovery techniques. The recovered oil is returned generally to slop oil storage while the remaining solids are collected and discarded as waste.

Once a tank is taken out of service, many refineries use *in situ* and *ex situ* oil recovery techniques. Common *in situ* oil recovery techniques include hot distillate washing, and steam stripping. This allows entrapped oil to float to the top of the sediment layer and be recovered prior to removal of the sediment from the tank. *Ex situ* recovery methods are usually performed by a contractor at the tank site and include filtration, centrifuging, and settling. Separated oil is recycled back to the process or sent to the slop oil tanks, and the water phase is sent to the wastewater treatment plant (WWTP). The solids are managed in a variety of ways, but primarily are disposed of in Subtitle C and D landfills (78 percent in 1992).

Many refineries reduce tank bottom buildup with in-tank mixers. Mixers keep the sediments or solids continuously in suspension so that they travel with the residual oil.

In 1992, less than one percent of the volume of residual oil tank bottom sludge was reported to be managed as hazardous.<sup>6</sup> Of the few refineries that reported a hazardous waste designation for this residual in 1992, only one reported a hazardous waste code (the others specified handling the sludge as hazardous without designating a code).

### 3.12.1.2 Generation and Management

The refineries reported generating 9,107 MT of residual oil tank bottom sludge in 1992. Residual oil tank sludge includes sludges from No. 6 oil and similar product tanks. Sludges from tanks identified as containing a mixture of residual oil and clarified slurry oil were included in the scope of K170 and are omitted here. Residuals were assigned to be “residual oil tank sludge” if they were assigned a residual identification code of “residual oil tank sediment,” corresponding to residual code “01-B” in Section VII.1 of the questionnaire. Process wastewaters, decantates, and recovered oils (e.g., from deoiling or dewatering operations) were eliminated from the analysis. These correspond to residual codes “09,” “10,” and “13” (newly added “recovered oil”) in the questionnaire. Quality assurance was conducted by ensuring that all residual oil tank sludges previously identified in the questionnaire (i.e., in Section V.D) were assigned in Section VII.1. Table 3.12.1 provides a description of the 1992 management practices, quantity generated, number of streams reported, number of streams not reporting volumes, and average volumes.

When cleaning a tank, it is common for refineries to use some type of *in situ* treatment, such as washing with lighter fuel, to recover oil from the top layers of sludge where there is a high percentage of free oil. However, treatment or recovery practices after this depend on the refinery's planned final management method. If land disposed (as most residual oil tank sludge was in 1992), low free liquid must be achieved; such levels can be achieved by sludge deoiling/dewatering or stabilization. A refinery may conduct this

---

<sup>6</sup>These percentages do not match up directly with any one of the management scenarios because the number of streams and the volume are a combination of several management scenarios (i.e., managed in WWTP, Subtitle C landfill, recovery onsite in coker, etc.).

**Table 3.12.1. Generation Statistics for Residual Oil Tank Sludge, 1992**

<b>Final Management</b>	<b># of Streams</b>	<b># of Streams w/ Unreported Volume</b>	<b>Total Volume (MT)</b>	<b>Average Volume (MT)</b>
Discharge to onsite wastewater treatment facility	1	0	47	47
Disposal in offsite Subtitle D landfill	13	4	6,458	496.8
Disposal in offsite Subtitle C landfill	8	0	622	77.8
Disposal in onsite Subtitle C landfill	2	0	4	2
Disposal in onsite Subtitle D landfill	3	0	30.4	10.1
Disposal in onsite surface impoundment	1	0	132	132
Offsite land treatment	1	1	4	4
Onsite land treatment	2	0	530.4	265.2
Other recycling, reclamation, or reuse: cover for onsite landfill	1	0	7.2	7.2
Recovery onsite via distillation	1	3	310	310
Transfer for use as an ingredient in products placed on the land	1	0	35	35
Transfer to another petroleum refinery	1	0	927	927
<b>TOTAL</b>	<b>35</b>	<b>8</b>	<b>9,107</b>	<b>260.2</b>

treatment for only some of the waste (e.g., the top layers); in the deeper sections of sludge where free liquid levels are lower no treatment may be performed. In addition to lower liquid levels, treatment or deoiling may be used to achieve lower levels of benzene or other hazardous properties.

### 3.12.1.3 Plausible Management

EPA believes that most of the plausible management practices for this residual were reported in the 1992 RCRA §3007 Survey, as summarized above in Table 3.12.1. The Agency gathered information suggesting other management practices have been used in other years including: “recovery onsite in an asphalt production unit” (9.2 MT), “transfer for direct use as a fuel or to make a fuel” (380.8 MT), “transfer with coke product or other refinery product” (5 MT), “onsite industrial furnace” (39 MT), “recycle to process” (unknown quantity), “recovery in coker” (unknown quantity), and “recovery in a catalytic cracker” (unknown quantity). These non-1992 management practices are generally comparable to the recycling practices reported in 1992.

#### 3.12.1.4 Characterization

Two sources of residual characterization were developed during the industry study:

- Table 3.12.2 summarizes the physical properties of residual oil tank sludges as reported in Section VII.A of the §3007 survey.
- Two record samples of actual residual oil sludge were collected and analyzed by EPA. These sludges represent the various types of treatment typically used by the industry and are summarized in Table 3.12.3.

Table 3.12.4 provides a summary of the characterization data collected under this sampling effort. The record samples collected are believed to be representative of residual oil tank sludges generated by the industry.

The samples collected of the composite of oily and de-oiled sediment are representative of industry treatment practices. As reported in the RCRA 3007 questionnaires, 10 of the 34 residual oil tank sludges (30 percent) that were ultimately managed in a land treatment or landfill in 1992 were deoiled in some manner, most often by filtration or centrifuge. This management resulted in volume reduction averaging 55 percent. Another 7 (20 percent) were stabilized, resulting in the volume increasing by an average of 55 percent. The remaining 17 residuals (50 percent) were not reported to be treated *ex situ* in any manner. The sampled refineries represent two alternative interim management procedures: free liquid reduction using stabilization (Amoco), and *ex situ* deoiling (Star). Therefore, the record samples represent the various types of *ex situ* treatment typically performed for residual oil tank sludge, but may not represent cases in which no treatment is performed. However, the same contaminants will be present in all three types of sludge (i.e., deoiled, stabilized, and untreated), but their levels may differ.

As illustrated in Table 3.12.4, none of the record samples exhibited a hazardous waste characteristic. Only constituents detected in at least one sample are shown in this table.

#### 3.12.1.5 Source Reduction

Only a small quantity of sludge was reported to be deoiled in 1992, as reported in the §3007 survey. Of the 34 residuals disposed in landfills or land treatment units in 1992, 10 residuals, totaling approximately 1,000 MT. The remaining 24 residuals, totaling approximately 7,600 MT, were reported to be untreated or underwent volume addition treatment (such as stabilization. As stated in Section 3.12.1.3, the average volume reduction achieved by deoiling was 55 percent (as calculated from those facilities providing sludge quantities prior to and following deoiling in 1992).

**Table 3.12.2. Residual Oil Tank Sludge: Physical Properties**

Properties	# of Values	# of Unreported Values <sup>1</sup>	10th %	Mean	90th %
pH	39	87	5.5	7	8.5
Reactive CN, ppm	27	99	0	0.3	5
Reactive S, ppm	27	99	0	2.5	15
Flash Point, °C	42	84	60	93.3	140
Oil and Grease, vol%	36	90	9	34.1	99
Total Organic Carbon, vol%	20	106	3.5	51	85.3
Vapor Pressure, mm Hg	11	115	0	0.1	10
Vapor Pressure Temperature, °C	9	117	25	37.8	38
Viscosity, lb/ft-sec	6	120	0.01	50.2	500
Specific Gravity	30	96	0.9	1.2	2.4
BTU Content, BTU/lb	16	110	600	5,000	20,000
Aqueous Liquid, %	78	48	0	0	50
Organic Liquid, %	82	44	0	18	86
Solid, %	91	35	1	60	100
Other, %	65	61	0	0	0
Particle >60 mm, %	4	122	0	0	0
Particle 1-60 mm, %	6	120	0	50	100
Particle 100 µm-1 mm, %	5	121	0	50	100
Particle 10-100 µm, %	4	122	0	0	1
Particle <10 µm, %	4	122	0	0	0
Median Particle Diameter, microns	3	123	0	0	15,000

<sup>1</sup>Facilities were not required to do additional testing, therefore information provided was based on previously collected data or engineering judgment.

**Table 3.12.3. Residual Oil Tank Sludge Record Sampling Locations**

Sample No.	Facility	Description:
R8B-RS-01	Amoco, Texas City, TX	Residual oil and CSO mixed. <sup>1</sup> Cleaning procedure: pumped down, mixed with diatomaceous earth, removed with backhoe.
R22-RS-01	Star, Port Arthur, TX	Residual oil. <sup>2</sup> Cleaning procedure: washed with lighter oil, centrifuged to generate cake.

<sup>1</sup>The refinery has a fluid catalytic cracking unit and generates CSO. An unknown quantity of CSO was stored in the sampled tank.

<sup>2</sup>The refinery has a fluid catalytic cracking unit and generates CSO. It is unknown if, or to what extent, CSO was stored in the sampled tank.

**Table 3.12.4. Residual Oil Tank Sludge Characterization**

Volatile Organics - Method 8260A µg/kg							
	CAS No.	R8B-RS-01	R22-RS-01	Average Conc	Maximum Conc	Comments	
n-Butylbenzene	104518	< 6,250	3,600	3,600	3,600	1	
Ethylbenzene	100414	13,000	J 1,600	7,300	13,000		
p-Isopropyltoluene	99876	< 6,250	J 470	470	470	1	
n-Propylbenzene	103651	J 6,850	J 1,600	4,225	6,850		
Toluene	108883	26,000	< 1,250	13,625	26,000		
1,2,4-Trimethylbenzene	95636	43,000	18,000	30,500	43,000		
1,3,5-Trimethylbenzene	108678	J 11,000	4,200	7,600	11,000		
o-Xylene	95476	19,000	J 1,800	10,400	19,000		
m,p-Xylenes	108383 / 106423	51,000	7,400	29,200	51,000		
Naphthalene	91203	64,000	19,000	41,500	64,000		
TCLP Volatile Organics - Methods 1311 and 8260A µg/L							
	CAS No.	R8B-RS-01	R22-RS-01	Average Conc	Maximum Conc	Comments	
Benzene	71432	110	< 50	80	110		
Ethylbenzene	100414	J 55	< 50	53	55		
Toluene	108883	690	< 50	370	690		
1,2,4-Trimethylbenzene	95636	J 79	< 50	65	79		
Methylene chloride	75092	B 1,200	< 50	625	1,200		
o-Xylene	95476	J 96	< 50	73	96		
m,p-Xylene	108383 / 106423	220	JB 28	124	220		
Naphthalene	91203	J 91	J 46	69	91		
Semivolatile Organics - Method 8270B µg/kg							
	CAS No	R8B-RS-01	R22-RS-01	Average Conc	Maximum Conc	Comments	
Acenaphthene	83329	60,000	27,000	43,500	60,000		
Anthracene	120127	150,000	< 4,125	77,063	150,000		
Benz(a)anthracene	56553	480,000	9,200	244,600	480,000		
Benzofluoranthene (total)	NA	130,000	34,000	82,000	130,000		
Benzo(g,h,i)perylene	191242	450,000	36,000	243,000	450,000		
Benzo(a)pyrene	50328	250,000	87,000	168,500	250,000		
Bis(2-ethylhexyl)phthalate	117817	< 10,313	10,000	10,000	10,000	1	
Carbazole	86748	< 20,625	J 16,000	16,000	16,000	1	
Chrysene	218019	800,000	170,000	485,000	800,000		
Dibenzofuran	132649	25,000	8,700	16,850	25,000		
Dibenz(a,h)anthracene	53703	65,000	J 8,000	36,500	65,000		
3,3'-Dichlorobenzidine	91941	< 10,313	87,000	48,656	87,000		
Fluoranthene	206440	120,000	< 4,125	62,063	120,000		
Fluorene	86737	160,000	38,000	99,000	160,000		
Indeno(1,2,3-cd)pyrene	193395	58,000	< 4,125	31,063	58,000		
Phenanthrene	85018	1,000,000	220,000	610,000	1,000,000		
Pyrene	129000	3,500,000	46,000	1,773,000	3,500,000		
1-Methylnaphthalene	90120	500,000	250,000	375,000	500,000		
2-Methylnaphthalene	91576	650,000	410,000	530,000	650,000		
2-Methylchrysene	3351324	380,000	< 8,250	194,125	380,000		
Naphthalene	91203	230,000	110,000	170,000	230,000		

**Table 3.12.4. Residual Oil Tank Sludge Characterization (continued)**

TCLP Semivolatile Organics - Methods 1311 and 8270B µg/L							
	CAS No.	R8B-RS-01	R22-RS-01	Average Conc	Maximum Conc	Comments	
Di-n-butylphthalate	84742	< 50	JB 24	24	24	1	
1-Methylnaphthalene	90120	J 28	J 54	41	54		
2-Methylnaphthalene	91576	J 37	J 74	56	74		
Naphthalene	91203	J 37	J 73	55	73		
Total Metals - Methods 6010, 7060, 7421, 7470, 7471, and 7841 mg/kg							
	CAS No.	R8B-RS-01	R22-RS-01	Average Conc	Maximum Conc	Comments	
Aluminum	7429905	9,100	38,000	23,550	38,000		
Arsenic	7440382	3.00	< 1.00	2.00	3.00		
Barium	7440393	< 20.0	230	125	230		
Beryllium	7440417	1.80	< 0.50	1.15	1.80		
Calcium	7440702	< 500	1,400	950	1,400		
Chromium	7440473	11.0	31.0	21.0	31.0		
Cobalt	7440484	130	< 5.00	67.5	130		
Copper	7440508	7.40	110	58.7	110		
Iron	7439896	1,600	11,000	6,300	11,000		
Lead	7439921	6.50	84.0	45.3	84.0		
Magnesium	7439954	< 500	4,300	2,400	4,300		
Manganese	7439965	12.0	67.0	39.5	67.0		
Mercury	7439976	1.50	< 0.05	0.78	1.50		
Molybdenum	7439987	330	18.0	174	330		
Nickel	7440020	410	83.0	247	410		
Sodium	7440235	< 500	3,200	1,850	3,200		
Vanadium	7440622	1,400	480	940	1,400		
Zinc	7440666	75.0	200	138	200		
TCLP Metals - Methods 1311, 6010, 7060, 7421, 7470, 7471, and 7841 mg/L							
	CAS No.	R8B-RS-01	R22-RS-01	Average Conc	Maximum Conc	Comments	
Aluminum	7429905	< 1.00	3.70	2.35	3.70		
Iron	7439896	< 0.50	10.0	5.25	10.0		
Manganese	7439965	< 0.08	1.10	0.59	1.10		
Zinc	7440666	B 0.26	1.20	0.73	1.20		

Comments:

- 1 Detection limits greater than the highest detected concentration are excluded from the calculations.

Notes:

- B Analyte also detected in the associated method blank.
- J Compound's concentration is estimated. Mass spectral data indicate the presence of a compound that meets the identification criteria for which the result is less than the laboratory detection limit, but greater than zero.
- ND Not Detected.
- NA Not Applicable.

*In situ* oil recovery techniques can greatly reduce the total amount of residual oil tank sludge to be disposed as well as reduce volatile constituents such as benzene. As discussed above, recovery methods include distillate washing, nonpetroleum solvent washing, water wash with surfactant, and steam stripping. These operations allow entrapped oil to float to the top of the sediment layer and be recovered prior to removal from the tank. Separated oil is recycled back to the process or sent to the slop oil tanks, and the water phase is sent to the WWTP.

Oily sludges are emulsions formed due to a surface attraction among oily droplets, water droplets, and solid particles. If the solids are large and dense, the resultant material will settle and become a sludge. The surface charge interactions between the solid particles and oil droplets cause the sludge to become stable and difficult to separate. However, the sludge can be separated into its individual components by mechanically removing the solids or by neutralizing the surface charge on the solids and oil droplets.

The predominant method of minimizing the formation of tank sludge is the use of mixers to keep the sludges continuously in suspension. A common mixer configuration is a sweeping mixer that automatically oscillates to produce a sweeping motion over the floor of the tank, keeping the heavy oil and particles suspended.

Of the twenty facilities that EPA visited, eight listed methods in recovering oil from tank sludges. Several facilities wash the tanks with light oils and water, whereas another facility washes with a surfactant followed by pressure filtration.

Reference	Waste Minimization/Management Methods
"Re-refiner Fluidizes Tank Residue Using Portable Mixer." <i>Oil &amp; Gas Journal</i> . September 5, 1994.	A portable mixer was used to cut lighter oil into the partially gelled residue.
Kuriakose, A.P., Manjooran, S. Jochu Baby. "Utilization of Refinery Sludge for Lighter Oils and Industrial Bitumen." <i>Energy &amp; Fuels</i> . vol.8, no.3. May-June, 1994.	Utilizing waste sludge.
"Environmental Processes '93: Challenge in the '90s." <i>Hydrocarbon Processing</i> . August, 1993.	A variety of technologies described, such as bioslurry treatment of oily wastes, oily-waste recovery, and evaporation/solvent extraction.
"Waste Minimization in the Petroleum Industry: A Compendium of Practices." API. November, 1991.	Sludge formation can be minimized by mixing contents of tank.



## BIBLIOGRAPHY

- 1992 RCRA §3007 Survey of the Petroleum Refining Industry Database.
- Department of Energy, Energy Information Administration. *Petroleum Supply Annual 1992, Volume 1*. May 1993.
- Donald Bonett, "ASTM D-396 Specification for No. 6 Fuel Oil," in *Proceedings, 1993 Fuel Oil Utilization Workshop*, Electric Power Research Institute, August 1994 (page 3-101).
- Fuel Oil and Kerosene Sales 1994*, U.S. Department of Energy, September 1995 (DOE/EIA-0340(92)/1).
- Hydrocarbon Processing*. "Refining Processes '94." November 1994.
- Hydrocarbon Processing*. "Gas Processing '94." April 1994.
- Kirk-Othmer. *Encyclopedia of Chemical Technology*. Third Edition, Volume 22. 1983.
- McKetta, John J. *Petroleum Processing Handbook*. Marcel Dekker, Inc. 1992.
- Meyers, Robert A. *Handbook of Petroleum Refining Processes*. McGraw-Hill Book Company. 1986.
- Perry's, 1950. John H. Perry, ed. *Chemical Engineer's Handbook*. McGraw-Hill, New York. Third edition, 1950.
- Speight, 1991. James Speight. *The Chemistry and Technology of Petroleum*. Marcel Dekker, New York. Second edition, 1991.