

R1715?

P1328

**CHEMICAL, MICROBIOLOGICAL, AND MUTAGENIC EFFECTS OF USING  
ALTERNATIVE DISINFECTANTS FOR DRINKING WATER TREATMENT**

by

**Benjamin W. Lykins, Jr.  
Kathleen M. Schenck  
Drinking Water Research Division  
Risk Reduction Engineering Laboratory  
U.S. Environmental Protection Agency  
Cincinnati, Ohio 45268**

**Wayne E. Koffskey  
Department of Public Works  
Jefferson Parish  
Jefferson, Louisiana 70121**

and

**Mark H. Griese  
Water Quality and Research  
Evansville Water & Sewer Utility  
Evansville, Indiana 47740**

**The University of Kansas  
42nd Environmental Engineering Conference  
Lawrence, Kansas  
February 5, 1992**

**RISK REDUCTION ENGINEERING LABORATORY  
OFFICE OF RESEARCH AND DEVELOPMENT  
U.S. ENVIRONMENTAL PROTECTION AGENCY  
CINCINNATI, OHIO 45268**

CHEMICAL, MICROBIOLOGICAL, AND MUTAGENIC EFFECTS OF USING  
ALTERNATIVE DISINFECTANTS FOR DRINKING WATER TREATMENT

Benjamin W. Lykins, Jr.  
Chief  
Systems and Field Evaluation Branch

Kathleen M. Schenck  
Biologist  
Systems and Field Evaluation Branch  
Drinking Water Research Division  
Risk Reduction Engineering Laboratory  
U.S. Environmental Protection Agency  
Cincinnati, Ohio 45268

Wayne E. Koffskey  
Chief Chemist  
Jefferson Parish Department of Public Utilities  
Jefferson Parish, Louisiana 70121

and

Mark H. Griese  
Manager  
Water Quality and Research  
Evansville Water And Sewer Utility  
Evansville, Indiana 47740

INTRODUCTION

Future Federal regulations for disinfection/disinfection by-products will potentially effect most water treatment plants in the United States. In anticipation of proposing regulations in June 1993, the U.S. Environmental Protection Agency is in the process of assessing the performance and potential health risks of several drinking water disinfectants and their by-products. In order to provide field data for this assessment and to more thoroughly understand the interactions of disinfection and disinfection by-product control regarding the advantages and disadvantages of a selected direction, studies were done at two drinking water utilities. This paper will discuss some of the results from these studies which consisted of a pilot plant evaluation at Jefferson Parish, Louisiana and bench-scale evaluations at Evansville, Indiana.

REGULATIONS

Existing disinfection/disinfection by-product regulations apply only to trihalomethanes with a maximum contaminant level (MCL) of 0.10 mg/L. Also, this regulation only applies to systems serving more than 10,000 people. Possible

future disinfection/disinfection by-product requirements will apply to all public water systems including non-community systems. Compounds likely to be regulated with MCLs when these regulations become effective are:

- Trihalomethanes (chloroform, bromodichloromethane, chlorodibromomethane, bromoform)
- Haloacetic acids (trichloroacetic acid, dichloroacetic acid)
- Chloral hydrate
- Bromate
- Chlorine, chloramines, chlorine dioxide, chlorate, chlorite

Over twenty compounds have been considered for regulation and those excluded at this time were done so for basically two reasons: (1) insignificant health risk at levels that occur in drinking water such as haloacetonitriles and chloropicrin, and (2) health risks not adequately characterized in time for the regulation such as the aldehydes. As far as the trihalomethanes are concerned, there are several options being considered. One option is to develop an MCL for each of the four trihalomethanes. Other options include: (1) an MCL for the total trihalomethanes or, (2) an MCL for each of the trihalomethanes and an MCL for the total trihalomethanes.

The reasons that these trihalomethane options are being considered are because the health risks for the individual trihalomethanes are significantly different, technical feasibility for limiting their formation can vary for each compound, and hopefully, the trihalomethane regulation can act as a surrogate to limit other halogenated by-products. Traditionally, drinking water standards for contaminants are set at the lowest possible number which is technically and economically feasible. However, one has to ensure that drinking water is microbiologically safe which may mean that a greater risk will have to be accepted from disinfectants and disinfection by-products than for other contaminants. An example of this is shown in Figure 1 where risk trade-offs have to be considered between microbial control and production of disinfection by-products.

#### ALTERNATIVE DISINFECTANT STUDIES

Jefferson Parish, Louisiana

For this study, raw river water from the Mississippi River was pumped to the full-scale plant where it was clarified with diallyldimethyl ammonium chloride or dimethylamine-type cationic polymers. After fluoridation, but before disinfection a portion of the clarified water was filtered through pressure sand filters before going to a 10 gallon-per-minute pilot plant. This pilot plant was operated in a conventional mode with disinfection followed by sand filtration. Post treatment consisted of granular activated carbon after sand filtration. Figure 2 shows the flow diagram for this mode of operation.

Each disinfectant contact chamber was 12.75 inches (320 mm) outside diameter and constructed of stainless steel. The chlorine, chloramine, and chlorine dioxide contact chambers were 10 feet (3m) in height, producing approximately 30 minutes disinfectant contact time with a flow of 2 gpm (0.13 L/s). The ozone contact chamber was 11 feet (3.3m) in height, with countercurrent operation consisting of water entering at the top of the contact chamber and ozone gas

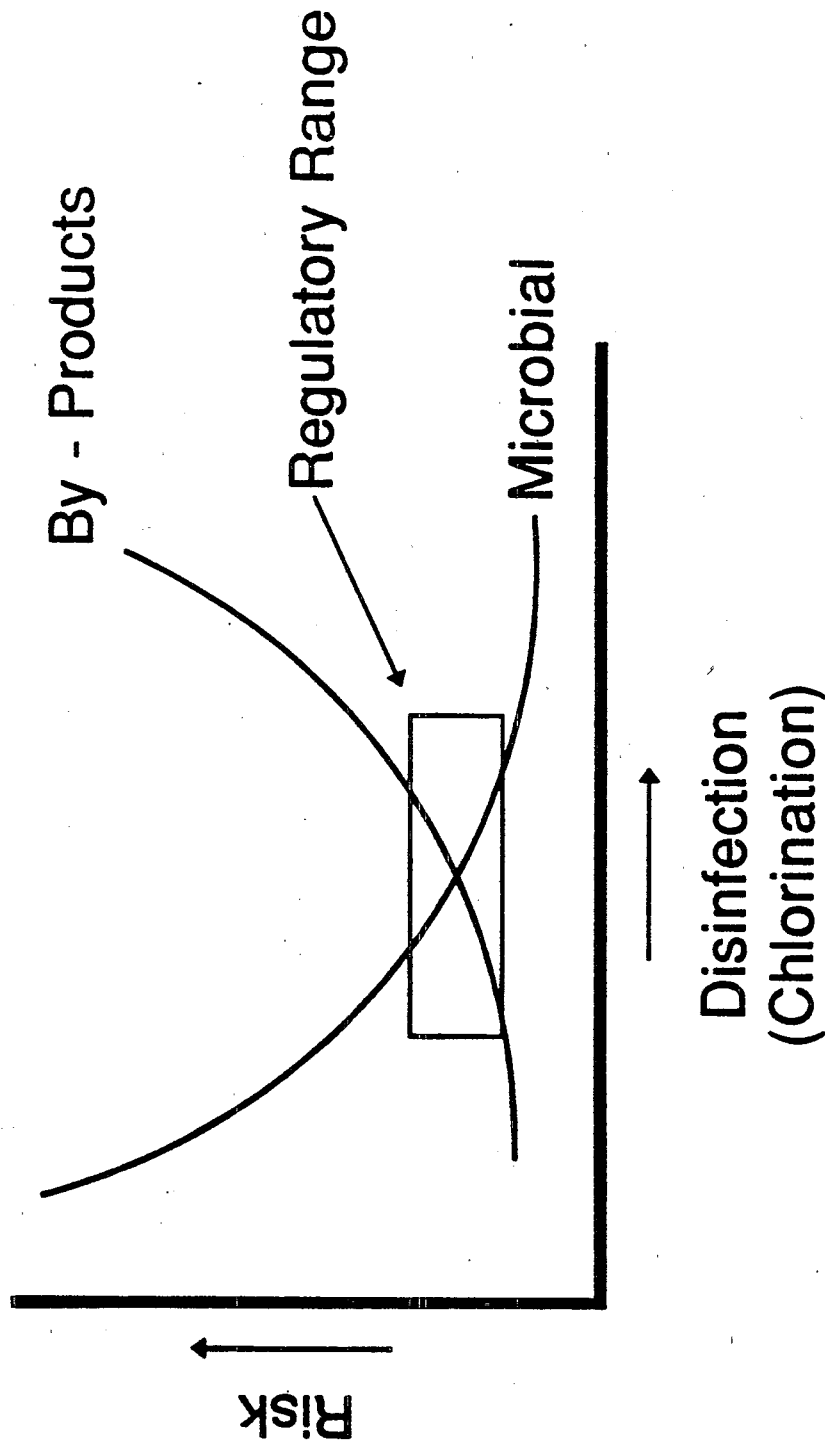

Figure 1. Disinfection / Disinfection By - Products  
Risk Trade - Offs

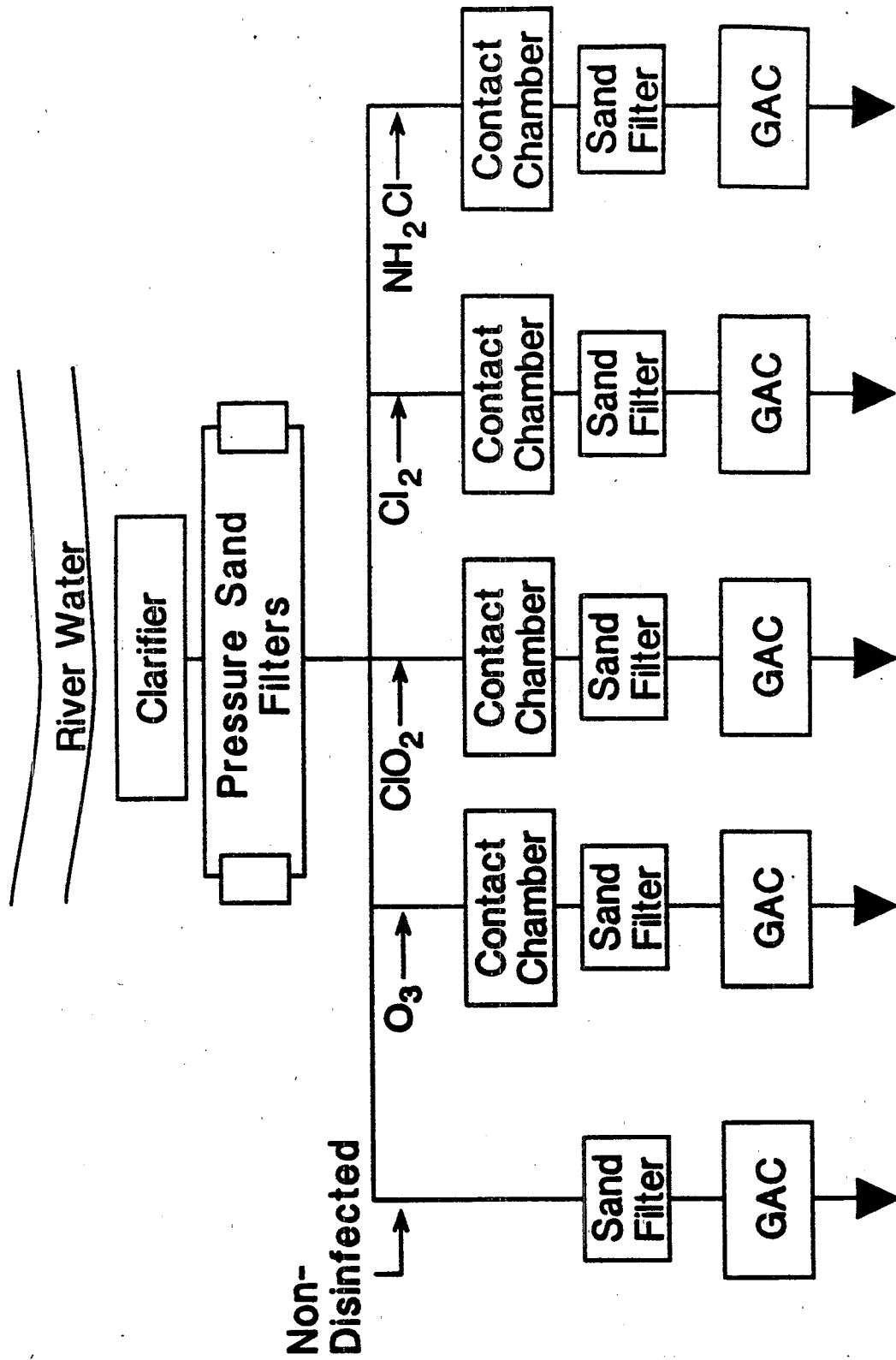

Figure 2. Flow Schematic of Jefferson Parish, LA Pilot Plant

entering at the bottom. The water and ozone gas influent lines were oriented so that the influent water would be in contact with the ozone gas stream for approximately 30 minutes.<sup>(1)</sup>

Ozone was generated from compressed dry air using an electrically powered ozone generator with a maximum output capacity of 0.25 lb/d (0.11 kg/d). Chloramine was produced by adding hypochlorous acid to the water stream a few seconds prior to the addition of ammonium hydroxide. Chlorine dioxide was generated using two solutions, one containing sodium chlorite and sodium hypochlorite and the other containing sulfuric acid. The final pH of the solution was 4. Chlorine was added in the form of hypochlorous acid. Residual concentrations after disinfection addition were maintained through the contact chambers to be comparable to those found in many drinking water utilities at the time the study was initiated. Average residuals were 1.0 mg/L chlorine, 2.1 mg/L monochloramine, 0.5 mg/L chlorine dioxide, and 0.5 mg/L ozone. The nondisinfected process stream was identical to the disinfected process streams except for elimination of the contact chamber. The major objectives of this study were to evaluate: (1) the microbiological effectiveness of the disinfectants, (2) the control of halogenated by-products, and (3) potential health effects associated with the use of these disinfectants.

### Microbiological Effectiveness

All of the disinfectants at the dosages used, reduced the coliforms to acceptable levels. However, with heterotrophic bacteria, all disinfectants except chloramines reduced the levels to below 100. Other organisms may not have been as effectively controlled by all disinfectants. For instance, during one study when MS2 Coliphage was spiked into the pilot plant, chloramines were ineffective for this virus indicator as shown in Table 1. Future studies at Jefferson Parish will apply the concentration x time (C\*t) concept for determining disinfectant efficiency. An example of these C\*t values that have been developed for inactivation of various microorganisms by the major disinfectants is shown in Table 2.

### Halogenated By-Product Control

During the one-year operation of the pilot plant, two surrogate parameters that give an indication of organic concentrations including halogenated by-products were evaluated: total organic carbon (TOC) and total organic halide (TOX). The average TOC concentrations in the disinfectant contact chamber effluents were 3.1, 2.9, 3.2, 3.2 and 3.2 mg/L for the nondisinfected, ozone, chlorine dioxide, chloramine, and chlorine process streams, respectively. There was some indication that ozone was reducing the TOC concentration while the concentration of TOC was fairly constant for the other disinfectants. Further in the treatment system after the ozone sand column, the TOC was reduced an additional 0.8 mg/L when compared to the nondisinfected system. Based on the levels of heterotrophic bacteria in the effluents of the ozone contact chamber and ozone sand column, the reduction of TOC across the ozone contact chamber appears to have resulted primarily from oxidation while that across the ozone sand column can be attributed to biodegradation.

With an average nondisinfected influent concentration of 25  $\mu\text{g/L}$ , TOX concentration increased significantly after 30 minutes of disinfectant contact time

TABLE 1. JEFFERSON PARISH MICROBIOLOGICAL DATA

<u>STEAM</u>	<u>RESIDUAL (mg/L)</u>	<u>MS2 COLIPHAGE (mL)</u>	<u>COLIFORM (100 mL)</u>	<u>HPC (mL)</u>
NONDISINFECTANT	-	400,000	640	43,000
OZONE	0.3	<1	0	14
CHLORINE DIOXIDE	0.5	1	0	57
FREE CHLORINE	1.0	<1	0	44
CHLORAMINE	1.9	46,000	0	270

TABLE 2. SUMMARY OF C\*t VALUE RANGES FOR INACTIVATION OF VARIOUS MICROORGANISMS BY DISINFECTANTS <sup>(2,3,4)</sup>

Micro-organism	Disinfectant			
	Free Chlorine pH 6 to 7	Preformed Chloramine pH 8 to 9	Chlorine Dioxide pH 6 to 7	Ozone pH 6 to 7
<u>E. Coli</u>	0.034-0.05	95-180	0.4-0.75	0.02
Polio 1	1.1-2.5	768-3740	0.2-6.7	0.1-0.2
Rotavirus	0.01-0.05	3806-6476	0.2-2.1	0.006-0.06
Phage f <sub>2</sub>	0.08-0.18	ND	ND	ND
<u>G. lamblia</u> cysts	47->150	2200 <sup>(a)</sup>	26 <sup>(a)</sup>	0.5-0.6
<u>G. muris</u> cysts	30-630	1400	7.2-18.5	1.8-2.0
<u>Cryptosporidium parvum</u>	7200 <sup>(b)</sup>	7200 <sup>(c)</sup>	78 <sup>(c)</sup>	5-10 <sup>(b)</sup>

NOTE: All C\*t values are for 99% inactivation at 5°C except for Giardia lamblia and Cryptosporidium parvum.

- (a) Values for 99.9% inactivation at pH 6-9
- (b) 99% inactivation at pH 7 and 25°C
- (c) 90% inactivation at pH 7 and 25°C

ND - no data



for chlorine dioxide, chloramine, and chlorine to 86, 99, and 246  $\mu\text{g}/\text{L}$ , respectively. The same trend seen for TOC was also observed for TOX where an average reduction of 33 percent occurred in the ozone contact chamber producing an average effluent concentration of 16  $\mu\text{g}/\text{L}$  with a further reduction to 11  $\mu\text{g}/\text{L}$  across the ozone sand column. Treatment of the sand filtered effluents with free chlorine followed by 5 day storage to simulate the distribution system significantly increased TOX concentrations for all process streams (557, 540, 339, and 379  $\mu\text{g}/\text{L}$  for nondisinfected, chlorine, ozone, and chlorine dioxide, respectively).

The trihalomethanes (THMs) reacted as expected with no significant concentrations (1  $\mu\text{g}/\text{L}$  average) observed in the disinfectant contact chamber and sand column effluents of the nondisinfected, ozone, and chlorine dioxide process streams. An average THM concentration of 3  $\mu\text{g}/\text{L}$  occurred in the chloramine disinfectant contact chamber and sand column effluents while that in the chlorine contact chamber effluent averaged 39  $\mu\text{g}/\text{L}$  and increased to 49  $\mu\text{g}/\text{L}$  across the chlorine sand column. By maintaining a chloramine residual for 5 days, the terminal THM concentrations increased slightly to an average of 8.5, 3.2, 4.2, and 9.4  $\mu\text{g}/\text{L}$  for the nondisinfected, ozone, chlorine dioxide, and chloramine process streams, respectively. Similar treatment and storage with free chlorine produced relatively high terminal THM concentrations for the nondisinfected and chlorine process streams with average concentrations of 236 and 225  $\mu\text{g}/\text{L}$ . When compared to the nondisinfected sand column effluent, terminal THMs were 35 and 41 percent less when ozone and chlorine dioxide were used during pretreatment resulting in average concentrations of 154 and 138  $\mu\text{g}/\text{L}$ , respectively. As expected, granular activated carbon (GAC) reduced all concentrations until the columns became saturated in 60 to 80 days.

The haloacetic acids followed the same trend as seen with THMs except at a lower concentration. The highest concentrations were formed using free chlorine which mainly produced dichloroacetic acid (DCAA), trichloroacetic acid (TCAA), and bromochloroacetic acid (BCAA). Chloroacetic acid (CAA), bromoacetic acid (BAA), and dibromoacetic acid (DBAA) were also formed to some extent. Average instantaneous concentrations for dichloroacetic acid were 0.9, 1.7, 3.7, 1.1, and 13  $\mu\text{g}/\text{L}$  for the nondisinfected, chlorine dioxide, chloramine, ozone, and chlorine process streams after sand filtration, respectively. Five-day terminal values for the same process streams with free chlorine were 60, 44, 38, and 60  $\mu\text{g}/\text{L}$  for the nondisinfected, chlorine dioxide, ozone, and chlorine streams, respectively.

Similar treatment of the sand filter effluents with chloramine and a 5 day storage period resulted in only slightly elevated DCAA concentrations. The slight concentration increase is similar to that seen for THMs during similar treatment with chloramine suggesting that both were formed by free chlorine during in-situ formation of chloramine. GAC adsorption produced continued removals of 80% or greater of DCAA after steady-state which was about 150 days of operation. GAC steady-state was reached in about 250 days for DCAA after storage for five days with a free chlorine residual. After GAC steady-state, average removals were 48, 73, 53, 46, and 51 percent for the nondisinfected, ozone, chlorine dioxide, chloramine, and chlorine process streams, respectively. Similar observations for all unit processes were also seen for TCAA.

Relatively low concentrations of haloacetonitriles were formed across each process stream with chlorine producing the highest levels which averaged 3.1  $\mu\text{g}/\text{L}$  total haloacetonitriles. Less than 1  $\mu\text{g}/\text{L}$  average of haloacetonitriles was

observed across the other process streams. The predominant haloacetonitrile (HAN) was dichloroacetonitrile (DCAN) followed by bromochloroacetonitrile (BCAN), dibromoacetonitrile (DBAN), and trichloroacetonitrile (TCAN). Treatment of the chlorine sand column effluent with additional free chlorine and subsequent 5-day storage produced an average concentration of 1.9  $\mu\text{g}/\text{L}$  of DCAN which was the same as that of the sand column effluent suggesting that all DCAN precursors had reacted. No consistent breakthrough of the HANs was observed through any GAC column except that of the chlorine process stream, which was still removing over 95% of the influent HANs at the end of the one-year operational period.

Only two haloketones, 1, 1, 1-trichloropropane (TCP) and 1, 1-dichloropropane (DCP) were detected with the highest concentration (1 to 2  $\mu\text{g}/\text{L}$ ) being observed in the chlorine process stream. Post chlorination of the sand column effluents followed by 5-day storage produced similar TCP concentrations in each process stream with average concentrations of 2.1, 2.5, 4.2, and 2.5  $\mu\text{g}/\text{L}$  for the nondisinfected, ozone, chlorine dioxide, and chlorine, respectively. Although consistent breakthroughs of these haloketones were observed across the GAC columns, removals remained above 85 percent throughout the one-year operational period.

Chloral hydrate (CH) was formed predominantly in the chlorine process stream with an average contact chamber effluent concentration of 2.9  $\mu\text{g}/\text{L}$  which increased to 4.5  $\mu\text{g}/\text{L}$  across the sand filter because of an additional 30 minutes chlorine contact time. The CH concentrations in the effluent of the chloramine contact chamber and sand column were identical averaging 0.25  $\mu\text{g}/\text{L}$ . CH was detected intermittently in the contact chamber and sand column effluents of the chlorine dioxide, ozone, and nondisinfected process streams at average concentrations ranging from 0.01 to 0.07  $\mu\text{g}/\text{L}$ . Post-treatment of the sand column effluents with free chlorine and storage for 5 days produced relatively similar CH concentrations averaging 79, 55, 45, and 75  $\mu\text{g}/\text{L}$  for the nondisinfected, ozone, chlorine dioxide, and chlorine process streams, respectively. Similar treatment with chloramine produced average concentrations of 0.03 to 0.3  $\mu\text{g}/\text{L}$ . GAC adsorption removed all of the CH throughout the project in all process streams.

The concentrations of chloropicrin (CP) in the effluents of the disinfection contact chambers and the sand columns were the same, averaging 0.004, 0.004, 0.015, 0.038, and 0.43  $\mu\text{g}/\text{L}$  for the nondisinfected, ozone, chlorine dioxide, chloramine, and chlorine process streams, respectively. Chlorination and 5-day storage of the sand column effluents produced concentrations averaging 1.3, 7.7, 1.4, and 1.3  $\mu\text{g}/\text{L}$  for the nondisinfected, ozone, chlorine dioxide, and chlorine process streams, respectively. Pre-ozonation appears to have produced an increase in CP precursors. Only slight increases in CP concentrations were observed after similar chloramine treatment and storage of the sand column effluents with average concentrations of 0.03, 0.04, 0.11, and 0.09  $\mu\text{g}/\text{L}$  for the nondisinfected, ozone, chlorine dioxide, and chloramine, respectively. No consistent breakthrough of CP above 0.003  $\mu\text{g}/\text{L}$  was observed across the GAC column of any process throughout the operational period.

## MUTAGENICITY STUDIES (Jefferson Parish, Louisiana)

### Sample Disinfection

For the health-related studies at Jefferson Parish, a portion of the clarified water after fluoridation was filtered through pressure sand filters and split into four process streams as shown in Figure 3. Three of these streams were disinfected with either chlorine, chloramine, or ozone while the fourth stream was not disinfected and served as a control. Chlorine dioxide was not evaluated at this time because it appeared that chlorine dioxide would not be an acceptable disinfectant when the disinfection/disinfection by-product regulation was promulgated. The system used for the three disinfected streams consisted of a contact chamber followed in series by a sand column and a 55-gallon stainless-steel drum fitted with a spiral stainless-steel baffle. The modified drum served as an additional contact chamber. The system for the nondisinfected stream was similar except that the initial contact chamber was omitted. The contact time in the contact chamber was approximately 30 min for each of the disinfected streams and the empty-bed contact time for the sand column was approximately 20 min. The ozone stream was split after the sand column and post-disinfected with either chlorine or chloramine. As a result of stream splitting, the flow rate to the two post-disinfected drums was decreased. Therefore, the contact time for post-disinfected drums was approximately 150-180 min while the contact time for the non-ozonated chlorine and chloramine streams and the nondisinfected stream was approximately 85-100 min. The amount of chlorine and chloramine added to the two ozonated streams was adjusted so that the residual disinfectant concentration leaving the drums matched the corresponding final residuals observed for the chlorinated and chloraminated (non-ozonated) streams (0.5-1.0 ppm  $\text{Cl}_2$  and 0.8-1.5 ppm  $\text{NH}_2\text{Cl}$ ).

### SAMPLE COLLECTION

Macroreticular resins (Amberlite XAD-8 and XAD-2) were used to collect and concentrate the organic compounds from the process streams for chemical and toxicological testing. The concentration procedure described by Miller et al.<sup>(5)</sup> was used with the following modifications. Ethyl acetate was utilized instead of acetone to elute the organic material from the XAD resins and the ratio of sample volume to resin volume was decreased from 760:1 to 150:1. The change in ratio was made to minimize the potential breakthrough of MX, 3-Chloro-4 (dichloromethyl)-5-hydroxy-2(5H)-furanone, and compounds with similar solubilities in water. The XAD resins were cleaned by Soxhlet extraction with ethyl acetate and methanol for 24 hr and stored in methanol. Prior to sample collection, each column pair containing 5 L of XAD-8 and XAD-2 resin was flushed with 200 L of water to remove the residual methanol. Fifteen hundred liters of each of the process streams were passed through the column pairs serially at a flow rate of 60 L/min. The pH of the column influent was maintained at pH 2 by the in-line addition of 9N hydrochloric acid.

Following sample collection, each column was filled with sufficient ethyl acetate to provide a standing head. The columns were then agitated to completely wet the resin and allowed to equilibrate for 15 minutes. Each column pair was then eluted serially with 15 L of ethyl acetate. Residual water was removed from the ethyl acetate extract by allowing the water to separate and then draining off the water in a separatory funnel. Each extract was concentrated to <1.5 L under

Toxicologic Sampling

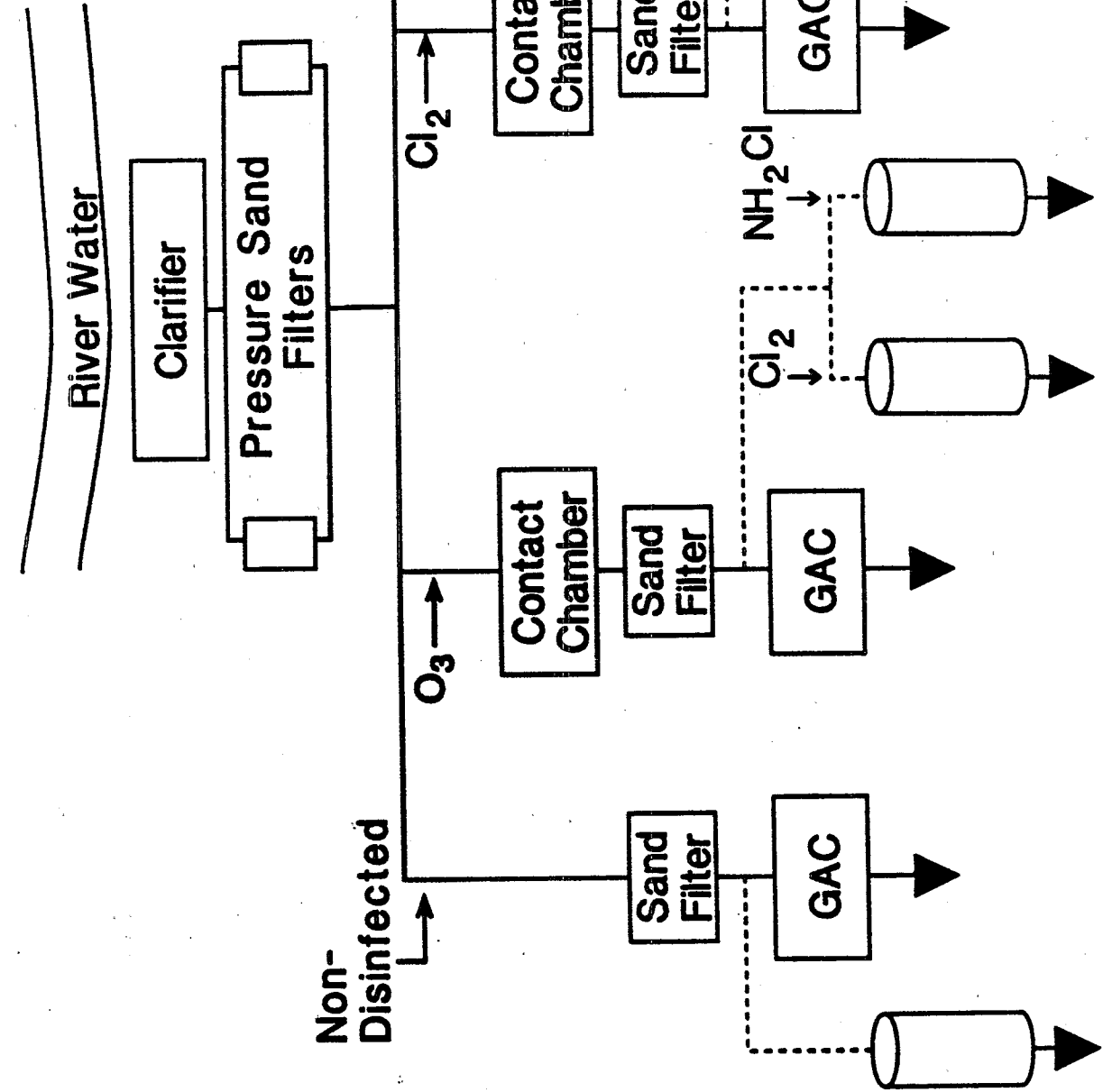

Figure 3. Toxicologic Sampling Scheme at Jefferson Parish, LA

vacuum at 40°C by rotary evaporation. The samples were each adjusted to exactly 1.5 L with ethyl acetate before storing at 4°C. Immediately prior to chemical or toxicity testing, aliquots of the 1000X concentrates were further concentrated by rotary concentration at 40°C.

## RESULTS AND DISCUSSION

Three rounds of water sample concentrates were collected during September 1989, March 1990, and July 1990. An examination of the seasonal effects (early fall-89, early spring-90, and mid summer-90) of finished water quality and surrogate parameters for the control stream (non-disinfected + sand) showed that the early spring sample had the lowest values for: pH (7.3), dissolved solids (184 mg/L), TOC (2.8 mg/L), and TOX (15.7 ug/L). The early spring sample also had the lowest concentrations for eight volatile organics examined. This latter finding may simply be a consequence of the lower TOC levels in the spring sample that may result from a flushing of naturally occurring organic matter from the source water over the course of the winter. However, it should be noted that TOX values observed for the (Cl<sub>2</sub> + sand) and (NH<sub>2</sub>Cl + sand) samples were highest for the spring sample. This suggested that the nature of the precursor material was different and that more semivolatile and nonvolatile halogenated compounds were formed. This idea is supported by the observed increase in the formation of haloacetic acids.

Significantly lower values were obtained for the spring sample with regard to brominated compounds (bromodichloromethane, dibromochloromethane, and bromoform). The most likely causes being either a decrease in the bromide content in the source water or an increase in the ammonia level of the source water that would result in the formation of combined bromine rather than free bromine. As for the effect of seasonal changes on the formation of halogenated by-products, the differences appeared to be less well defined. However, the over-all formation of brominated DBPs was spring < summer < fall.

Many of the halogenated by-products of interest were analyzed for each disinfectant stream. <sup>(6,7,8)</sup> Of special interest was the potential concentration of these by-products when water is delivered to the customer. This was evaluated by storing samples for 5 days with a disinfectant residual to simulate concentrations in the distribution system. An example of the effects of using different disinfection alternatives for the September 1989 sampling is shown in Table 3. These data show a definite trend. For example, with dichloroacetic acid, when chlorine is added prior to and after sand filtration about 45 µg/L, on average, was detected. If ozone is added prior to sand filtration and chlorine after sand filtration, this average concentration was reduced to 32 µg/L. If however, monochloramine is used prior to and after sand filtration, the average concentration is reduced to about 8 µg/L. Further reductions were seen when ozone was added before sand filtration and monochloramine after sand filtration (4.6 µg/L average). This trend was seen for other prevalent halogenated by-products such as trichloroacetic acid, bromochloroacetic acid, chloral hydrate, and trichloromethane.

A similar trend is seen for mutagenicity studies on samples collected at Jefferson Parish as shown in Figure 4. From these data, one might conclude that ozonation prior to sand filtration and chloramination after sand filtration will

TABLE 3. JEFFERSON PARISH DISINFECTION BY-PRODUCT FORMATION  
 POTENTIAL FOR SELECTED STREAMS (SEPTEMBER 1989)  
 Concentration in  $\mu\text{g/L}$

<u>BY-PRODUCT</u>	<u>NONDIS.</u>	<u>Cl<sub>2</sub>- SAND- Cl<sub>2</sub></u>	<u>OZONE- SAND- Cl<sub>2</sub></u>	<u>NH<sub>2</sub>Cl- SAND- NH<sub>2</sub>Cl</u>	<u>OZONE- SAND- NH<sub>2</sub>Cl</u>
Chloroacetic Acid	0.	16.0	17.0	0.4	0.6
Dichloroacetic Acid	0.5	44.9	32.3	8.2	4.6
Trichloroacetic Acid	0.2	39.8	19.0	1.7	0.7
Bromoacetic Acid	0.	1.2	1.0	0.1	0.1
Dibromoacetic Acid	0.	0.8	1.2	0.1	0.1
Bromochloroacetic Acid	0.2	28.7	20.2	3.8	1.4
Dichloroacetonitrile	0.1	1.6	1.3	0.	0.
Trichloroacetonitrile	0.	0.1	0.	0.	0.
Dibromochloroacetonitrile	0.	0.3	0.4	0.	0.
Bromochloroacetonitrile	0.	0.7	0.7	0.	0.
1,1-Dichloropropane	0.1	0.1	0.1	0.	0.
1,1,1-Trichloropropane	0.	1.8	1.7	0.	0.
Chloropicrin	0.	0.9	4.2	0.	0.
Chloral Hydrate	0.	37.5	32.6	0.1	0.
Trichloromethane	1.0	156.	121.	5.3	1.8
Bromodichloromethane	0.4	35.0	29.0	1.2	0.5
Dibromochloromethane	0.1	8.	10.0	0.1	0.1
Tribromomethane	0.1	0.	1.0	0.	0.1
TOX	27.	505.	328.	55.	29.

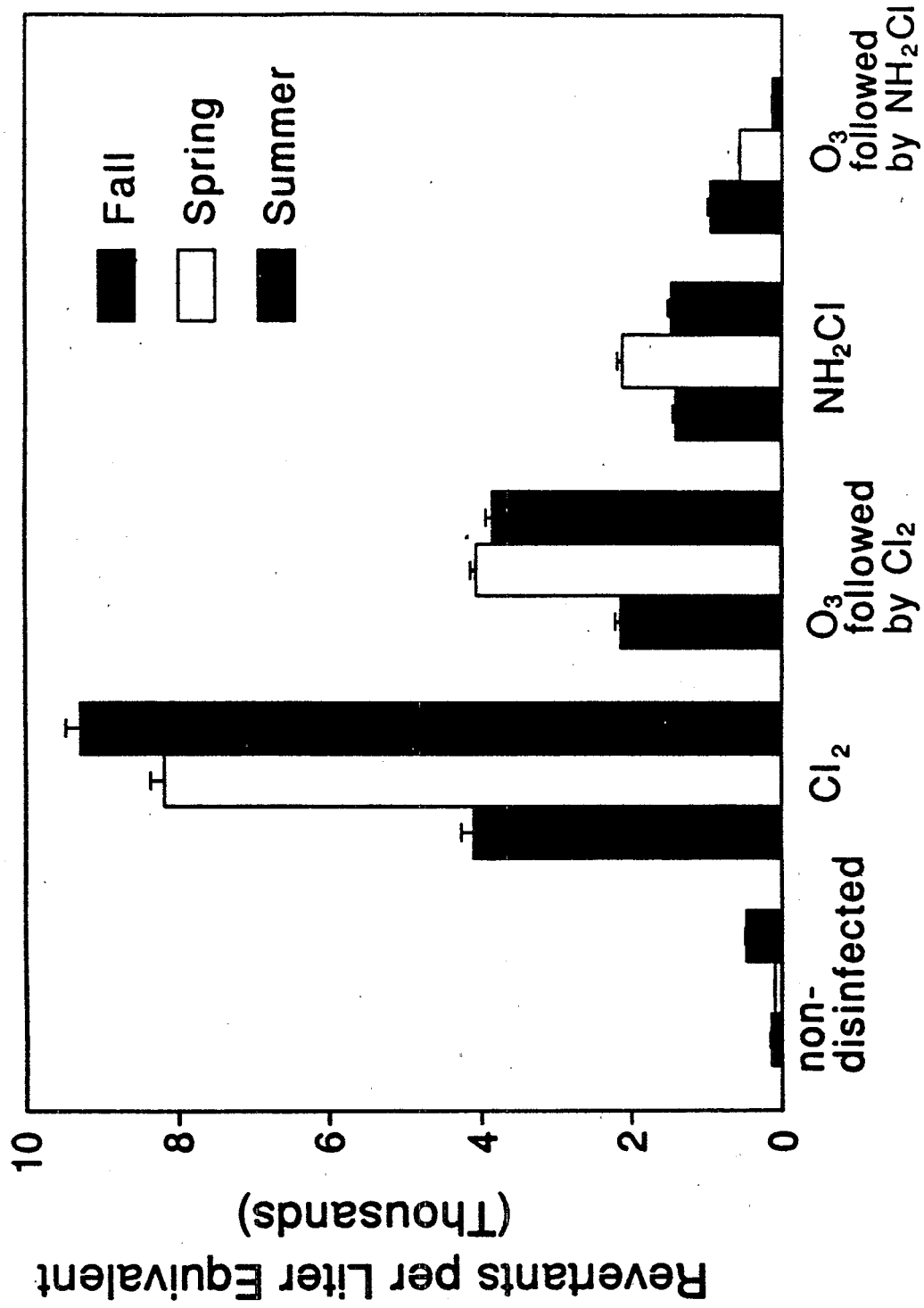

Figure 4. Direct Acting Mutagenicity in Strain TA100 of Jefferson Parish Pilot Plant Water Samples Disinfected by Alternative Methods

solve the halogenated by-product problem. This is true but one also has to evaluate the total impacts of disinfection. For instance, although ozone shows promise and may be a viable disinfection alternative, assimilable organic carbon (AOC) increase in the distribution system has to be controlled. This can be done by biostabilization of the water during treatment before distribution. An example of this is shown in Table 4. In this example, after ozonation, 162  $\mu\text{g/L}$  of AOC is present. Sand filtration provides some biostabilization by reducing the AOC to 38  $\mu\text{g/L}$  while the GAC effluent is 4  $\mu\text{g/L}$ ; comparable to the AOC concentration (3.7  $\mu\text{g/L}$ ) in the chlorine contact chamber effluent. Ozonation by-products such as aldehydes, ketones, and acids are also a concern. Although chloramines may be the disinfectant of choice to provide a disinfection residual, it may not provide the desired disinfection effectiveness and there have been some health concerns with ingesting chloramines.

#### EVANSVILLE, INDIANA STUDIES

Another potential disinfectant for controlling halogenated by-products, is chlorine dioxide which was further evaluated beyond the scope of the Jefferson Parish project. At a drinking water utility on the Ohio River, a pilot plant was used to compare chlorine dioxide disinfection with chlorine disinfection<sup>(9)</sup>. The addition of chlorine dioxide to the raw water with delayed chlorination permitted coagulation/settling/filtration and oxidation to remove trihalomethane precursors, thereby reducing the amount of trihalomethanes formed during post-treatment chlorination. A comparison of the average trihalomethane concentrations for the two disinfectant modes showed a reduction of approximately 60 percent when chlorine dioxide was used. Although chlorine dioxide disinfection can reduce trihalomethane concentrations, control of the metabolites (chlorite and chlorate) is essential before chlorine dioxide can be considered a viable disinfection alternative. Equipment is now available to produce chlorine dioxide that is virtually free of chlorine and chlorate. Bench-scale studies have recently been completed which evaluated the reduction of chlorite and chlorine dioxide by a reducing agent.<sup>(10)</sup>

All of the samples used for these studies were collected from the effluents of pilot plant secondary settling basins after approximately 200 minutes of chlorine dioxide contact time.<sup>(11)</sup> These grab samples were analyzed immediately for residual chlorine dioxide ( $\text{ClO}_2$ ), chlorite ( $\text{ClO}_2^-$ ), and chlorate ( $\text{ClO}_3^-$ ), treated with the respective reducing agent for a variety of contact times, and reanalyzed for the same chlorine dioxide species.

The major reducing agents considered for these studies consisted of sulfur dioxide, sodium thiosulfate, sodium metabisulfite, and ferrous iron. For sulfur dioxide, complete reduction of residual chlorine dioxide and chlorite ion was achieved but a marked increase in chlorate ion concentration was consistently observed as shown in Figure 5. This same phenomenon occurred with sodium metabisulfite. The degree of  $\text{ClO}_2$  reduction with sodium thiosulfate depended on pH and contact time. Removal of chlorite ion was demonstrated with little or no chlorate formation. However, the dosages required for complete reduction appear to make this reducing agent impractical. Ferrous iron appears to be an effective methodology for the removal of chlorine dioxide and chlorite ion residuals. Both of these undesirable finished water residuals were eliminated in minutes at pH 6.0 to 7.0 and preliminary results indicate that excess reductant may be easily controlled by pre-filter chlorination.



TABLE 4. AVERAGE AOC CONCENTRATION  
AT JEFFERSON PARISH, LA

<u>TREATMENT</u>	<u>AOC, ug/L</u>
NON DISINFECT	13.5
O <sub>3</sub> CONTACT CHAMBER	162.
O <sub>3</sub> -SAND	38.2
O <sub>3</sub> -SAND-GAC	4.0
Cl <sub>2</sub> CONTACT CHAMBER	3.7
Cl <sub>2</sub> -SAND-GAC	2.6

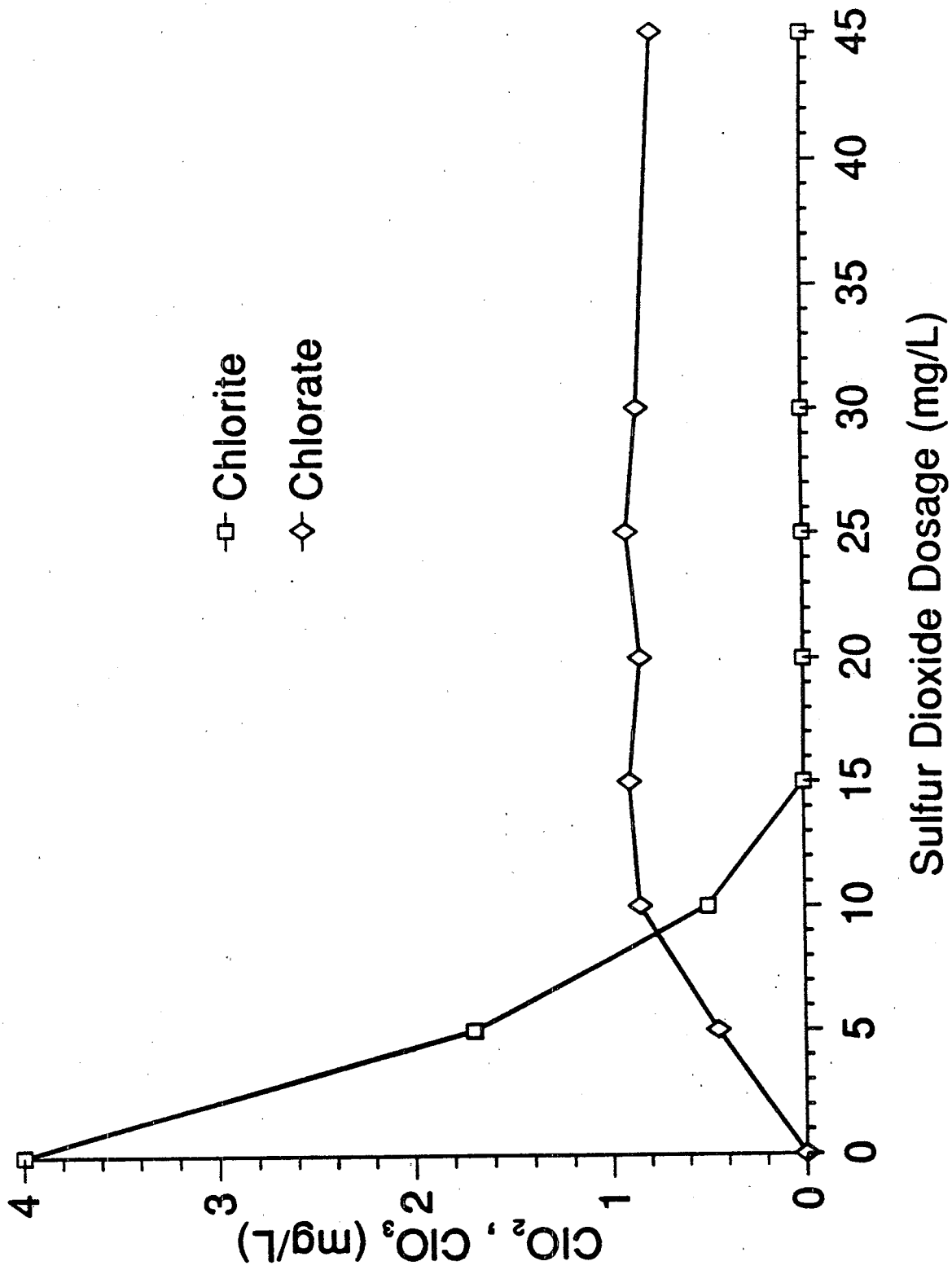

Figure 5. Chlorite Reduction by Sulfur Dioxide  
Evansville, IN

Bacterial mutagenicity was evaluated during a dual pilot plant study using ferrous iron in one train with chlorine dioxide disinfection and ozone in the other train (Figure 6). Figure 7 shows the results of these tests using the TA 100 strain. Regardless of whether chlorine dioxide or ozone is used as a pre-disinfectant, when GAC is incorporated into the treatment scheme, the mutagenicity is low when compared to the schemes incorporating dual media filtration.

#### SUMMARY

Regulations to control contaminants in drinking water in the United States are expected to become more stringent and more prevalent. Forthcoming disinfection and disinfection by-product regulations will effect virtually every community water system. There are various ways to control disinfection by-products, one of which is to use an alternative to chlorine. However, when this is done, one should consider various aspects of each disinfectant. There appears to be no single disinfectant that is applicable for all situations.

#### ACKNOWLEDGEMENTS

The authors acknowledge the assistance of Robert Miller, Paul Ringhand, and Ron Dressman for their help in sample collection, analyses, and data interpretation. The authors also thank Sandra Dryer, Pat Underwood, and Steve Waltrip for helping prepare this paper.

This paper has been reviewed in accordance with the U.S. Environmental Protection Agency's peer and administrative review policies and approved for presentation and publication. Mention of trade names or commercial products does not constitute endorsement or recommendation for use by the USEPA.

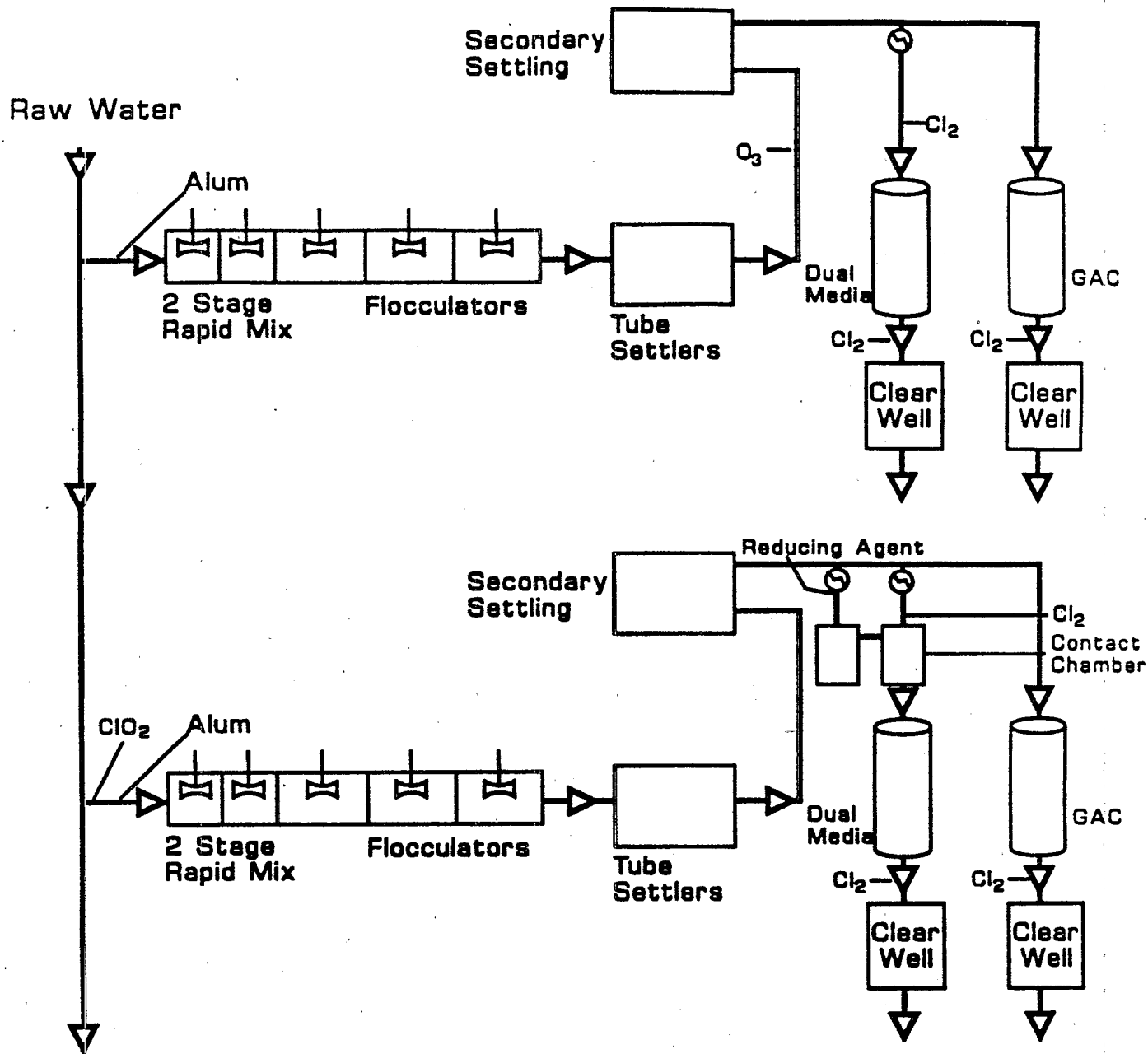

Figure 6. Evansville, Indiana Pilot Plant

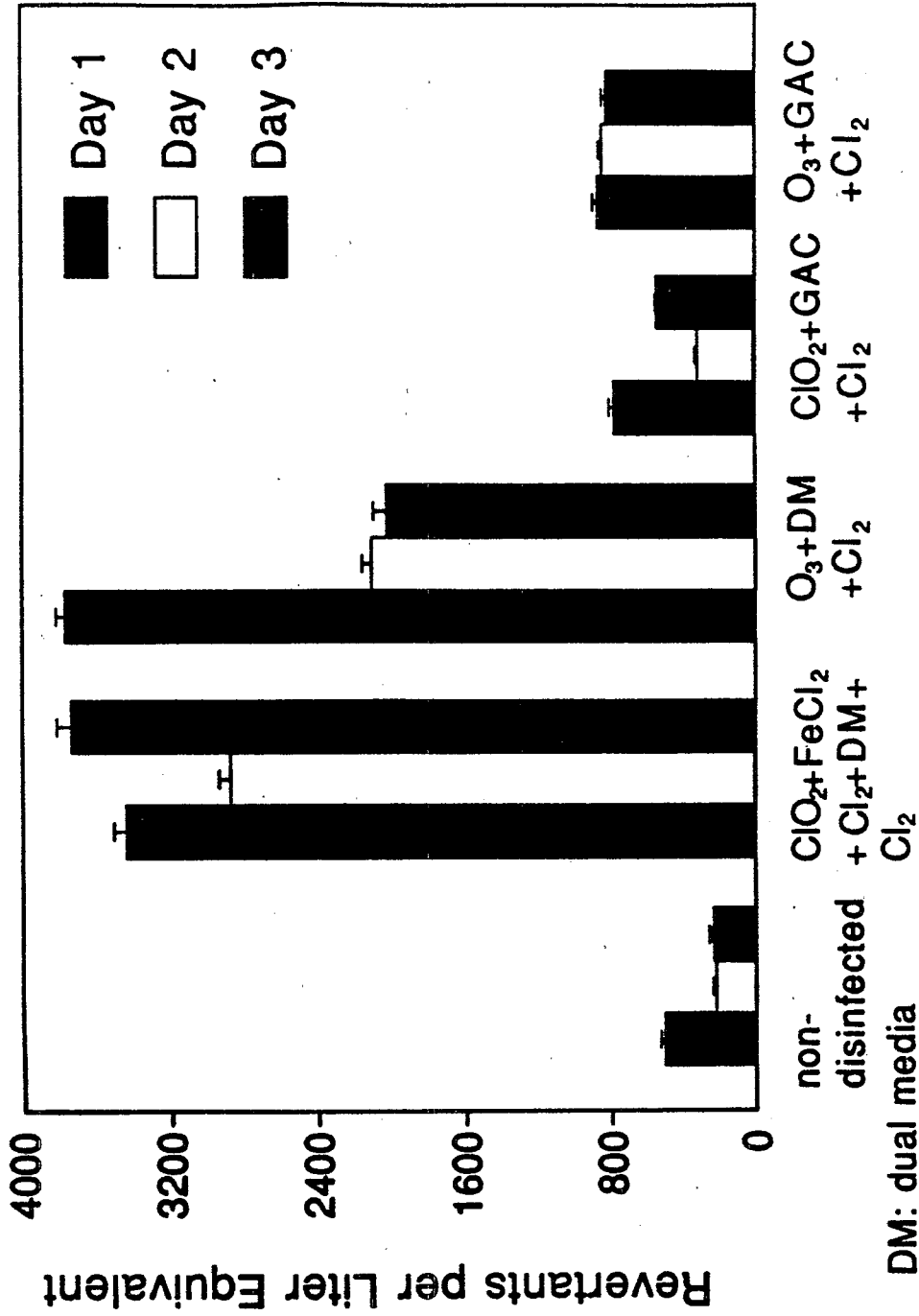

Figure 7. Direct Acting Mutagenicity in Strain TA100 of Evansville Water Samples Disinfected by Alternative Methods

## REFERENCES

1. Lykins, Jr. B.W., Koffskey, W.E., and Miller, R.G., "Chemical Products and Toxicologic Effects of Disinfection", Journal AWWA, 78:11, 66-75, 1986.
2. Hoff, J.C., "Inactivation of Microbial Agents by Chemical Disinfectants", U.S. EPA, EPA/600/2-86/067, 1986.
3. National Primary Drinking Water Regulations, Final Rule, Federal Register, 40 CFR Parts 141 and 142, Vol. 54, No. 124, Thursday, June 29, 1989.
4. Korich, D.G., Mead, J.R., Madore, M.S., Sinclair, N.A., and Miller, R.G., et al, "Results of Toxicological Testing of Jefferson Parish Pilot Plant Samples", Environmental Health Perspectives, Vol. 69, 129-139, 1986.
5. Miller, R.G., et al, "Results of Toxicological Testing of Jefferson Parish Pilot Plant Samples", Environmental Health Perspectives, Vol. 69, 129-139, 1986.
6. Lykins, Jr., B.W., et al "Ozone for Trace Organic Contaminant Removal", Proceedings of 1990 International Ozone Association Conference, Shreveport, Louisiana, March 27-29, 1990.
7. Lykins, Jr. B.W., Moser, R., and DeMarco, J., "Treatment Technology in the United States: Disinfection and Control of Disinfection By-Products", the 2nd Japan - U.S. Governmental Conference on Drinking Water Quality Management, Tokyo, Japan, July 24-26, 1990.
8. Lykins, Jr. B.W., "Disinfection of Drinking Water and Control of Disinfection By-Products in the United States", U.S./U.S.S.R. Bilateral Project, Cincinnati, Ohio, October 15, 1990.
9. Lykins, Jr. B.W. and Griese, M.H., "Using Chlorine Dioxide for Trihalomethane Control", Journal AWWA, 78:6, 88-93, 1986.
10. "Disinfection Byproduct Control Using Chlorine Dioxide", U.S. EPA Cooperative Agreement No. CR-816837, 1990.
11. Griese, M.H., et al., "The Use of Reducing Agents For the Total Elimination of Chlorine Dioxide and Chlorite Residuals in Drinking Water", Journal AWWA, 83:5, 56-61, 1991.