

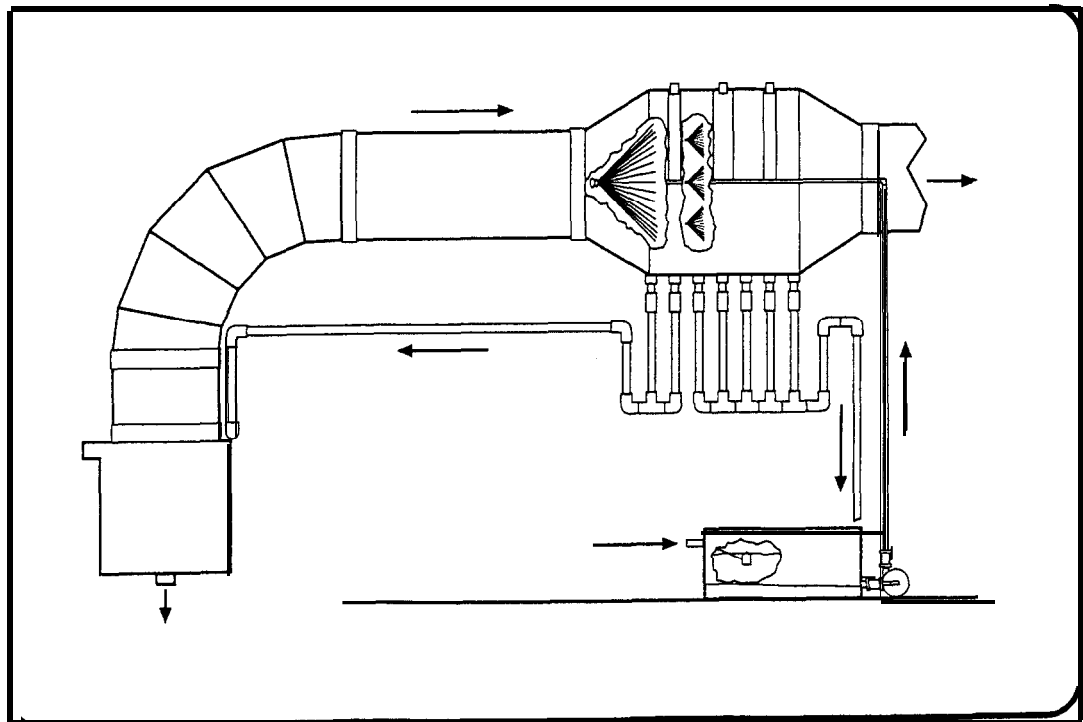

Capsule Report

Hard Chrome Fume Suppressants and Control Technologies



Capsule Report

Hard Chrome Fume Suppressants and Control Technologies

December 1998

Center for Environmental Research Information
National Risk Management Research Laboratory
Office of Research and Development
U.S. Environmental Protection Agency
Cincinnati OH 45268

Notice

This document has been reviewed in accordance with the U.S. Environmental Protection Agency's peer and administrative review policies and approved for publication. Mention of trade names or commercial products does not constitute endorsement or recommendation for use.

Acknowledgments

This capsule report was developed for the U.S. Environmental Protection Agency (EPA), Center for Environmental Research Information (CERI) in Cincinnati OH under Purchase Agreement No. 7C-R349-NTSX. Douglas Grosse, Office of Research and Development (ORD), National Risk Management Research Laboratory (NRMRL), Technology Transfer Branch, coordinated the preparation of this publication and provided technical direction throughout its development. David Ferguson, ORD/NRMRL, Sustainable Technology Division, provided technical consultation in the preparation of this document. Patrick Burke and John McCready of the Technical Information Branch, NRMRL, provided document production and graphics support.

This publication is the product of the efforts of many individuals. Principal authors of this document were Barrett J. Riordan and Rohit T. Karamchandani of Jack Faucett Associates, Inc., Bethesda, MD. Larry J. Zitko of Chrome Tech Inc., Windsor, OH and George C. Cushnie Jr. of the National Metal Finishing Resource Center (NMFRC) and CAI Engineering.

The following individuals peer reviewed this publication: David Szlag, and Diana Bless of the U.S. EPA, ORD, National Risk Management Research Laboratory, Cincinnati, OH; Paul Shapiro and Dean Menke, U.S. EPA, ORD, Washington, D.C.

TABLE OF CONTENTS

1	INTRODUCTION	1
2	BACKGROUND	1
3	CHROMIC ACID MIST CONTROL	3
4	EARLY DEVICES	4
4.1	Plastic floating spheres	4
4.2	Vertical moisture extractors	4
4.3	Chevron-blade mist eliminators	5
4.4	Early-generation packed-bed scrubbers	6
	MODERN DEVICES	7
5.1	Newer-generation packed-bed scrubbers	7
5.2	Mesh pad mist eliminators	9
5.3	Fiber bed mist eliminators	13
5.4	Encapsulating tank covers	14
5.5	Combination systems	15
	DEMONSTRATED PERFORMANCE OF MODERN DEVICES	17
6.1	Removal efficiency	17
6.2	Controlled emission rate	18
7	OPERATION & MAINTENANCE	19
8	FUME SUPPRESSANTS	20
8.1	Foam Blankets	20
8.2	Wetting Agents	21
8.3	Operation and Maintenance Requirements	22
9	RESOURCE INFORMATION	24
10	CONCLUSION	24
	REFERENCES	25

LIST OF FIGURES

Figure 1	Vertical Moisture Extractor	5
Figure 2	Blade Configurations Used in Chevron Mist Eliminators	6
Figure 3	Horizontal, Single Packed-Bed Scrubber	7
Figure 4	Three Stage Step-Down Composite Mesh Pad System	10
Figure 5	Vertical, In-Line Mesh Pad Mist Eliminator	11
Figure 6	Vertical Mesh Pad System	12
Figure 7	Mesh pad Device with Air-Cleaning Spray Nozzles and Wetted Stage	13
Figure 8	Fiber Bed Construction	14
Figure 9	Encapsulating Tank Cover with Membrane and Evacuation Systems	15
Figure 10	Combination In-Line and End-of-Line Mesh Pad Devices	16
Figure 11	Combination In-Hood and End-of-Line Mesh Pad Devices	17
Figure 12	Wetting Agent Concentration vs. Surface Tension	23
Figure 13	Surface Tension vs. Chromic Acid Emissions	23

LIST OF TABLES

Table 1	MACT Chrome Compliance Limits	2
Table 2	Monitoring Requirements for Ongoing Compliance	9
Table 3	Controlled Emissions from Modern Control Devices for Hard Chrome Plating	18

1 INTRODUCTION

The hard chromium electroplating industry has been affected by numerous air quality regulations on both state and federal levels. In 1995, the U.S. Environmental Protection Agency promulgated its *National Emission Standards for Chromium Emissions from Hard and Decorative Chromium Electroplating and Chromium Anodizing Tanks* (U.S. EPA, 1995 a). Under the standards, facilities that perform industrial or functional chrome plating must demonstrate that chromium emissions do not exceed acceptable limits, and must also satisfy monitoring, record-keeping and reporting requirements. Various chemical and mechanical strategies for air pollution control exist to accomplish these goals. This report evaluates the use of hardware control technologies and fume suppressants to extract, recover or suppress chromium emissions prior to venting the exhaust air to the atmosphere.

2 BACKGROUND

Since 1984, the U.S. Environmental Protection Agency (EPA) has been investigating chromium electroplating operations as a source of chromium air emissions. EPA and other agencies have determined that there is evidence to conclude that hexavalent chromium (Cr^{VI}) compounds can cause lung cancer in humans (Sax, 1979).

The Clean Air Act (CAA), as amended in 1990, directs EPA to regulate emissions of 189 toxic chemicals, including chromium compounds, from a wide range of industrial sources. On January 25, 1995, EPA published the final Maximum Achievable Control Technology (MACT) standard for chromium electroplaters, as required by the CAA Amendments of 1990. This rule applies to all facilities performing hard chromium electroplating, decorative chromium electroplating, and chromium anodizing. The MACT standard effectively treats all operations as area sources and subdivides existing hard chromium electroplating into large and small affected sources (i.e. individual hard chromium electroplating tanks.) A single facility can contain multiple large and small affected sources. The use of chemical fume suppressants is a major source reduction technique that inhibits chromium emissions at the source; the electroplating bath, itself. Table 1 describes the emission limits under the MACT standards for various sizes and types of electroplating operations. Emission limitations for chromium electroplating sources are expressed in milligrams per dry standard cubic meter of ventilation air (mg/dscm) or by the allowable surface tension expressed in dynes per centimeter (dynes/cm).

Table 1: MACT Chrome Compliance Limits

Type of tank	Small source emission limit (Maximum cumulative potential rectifier capacity (MCPRC): < 60 million amp hr/yr)	Large source emission limit (MCPRC: > 60 million amp hr/yr)
New, hard chromium electroplating (hexavalent)	3.015 mg/dscm (milligrams of total chromium per dry standard cubic meter of ventilation air)	
Existing, hard chromium electroplating (hexavalent)	0.03 mg/dscm	0.015 mg/dscm
New and existing decorative chromium electroplating (hexavalent chromic acid bath)	0.01 mg/dscm or surface tension less than or equal to 45 dynes/cm	
New and existing decorative chromium electroplating (trivalent chromium bath)	<ul style="list-style-type: none"> • Notify EPA that a trivalent chromium process incorporating a wetting agent in the bath components (as supplied from vendor) is being used, and provide bath components • Notify EPA if a change in the bath is made which puts it in a different compliance status 	
New and existing chromium anodizing	0.01 mg/dscm or surface tension less than or equal to 45 dynes/cm	
Research laboratories	Exempt	

(Source: Kansas, 1995)

If tank construction or reconstruction began after Dec. 16, 1993, the tank is considered “new”. Existing hard chrome plating tanks are categorized according to the size of the facility. Large existing facilities have the same 0.015 mg/dscm discharge limits as all new installations. Smaller existing facilities have a more lenient 0.03 mg/dscm discharge limit. The delineation between small and large facilities is established at 60 million ampere hours per year, which may be demonstrated using non-resettable ampere-hour counters, or may be calculated using the following equation:

$$(\sum RC) \times 8,400 \text{ hr/yr} \times 0.7$$

where: RC , = the rectifier capacity rating of an individual tank,
 8,400 hr/yr = operating schedule based on 24 hr/day x 7 days/week x 50 weeks/yr, and
 0.7 = the percentage of time the electrodes are energized.

These discharge limits make it difficult for older, early-generation air pollution control devices to meet the standards. All companies that perform hard chromium plating are required to demonstrate that stack gas emissions of chromium do not exceed the discharge limits for their category. This *compliance monitoring* obligation is satisfied by an initial performance test, intended to demonstrate the effectiveness of the air pollution control device. Facilities must perform this emission testing on each stack that vents an affected source tank, regardless of the previous success or failure of similar (or even identical) control equipment for other stacks. In order to demonstrate that the equipment is being maintained in good working order, companies must also satisfy provisions of the regulation that require *ongoing compliance monitoring, work practice standards, and an operation and maintenance plan* (U.S. EPA, 1995a).

3 CHROMIC ACID MIST CONTROL

Hard chromium electroplating is an electrolytic process. The workpiece to be plated is submerged in a solution of heated chromic acid, and made cathodic by bussing it to the negative pole of a suitable direct current (DC) power supply. Lead-alloy anodes serve as opposing electrodes, and are connected to the positive pole. The electrochemical processes that occur result in various anode and cathode reactions, including the electrodeposition of chromium and the release of gas.

In particular, hydrogen gas evolves at the cathode and oxygen at the anode (Lowenheim, 1978), as follows:

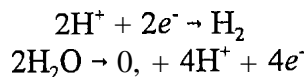

Due to the very low cathodic efficiency of the hard chromium plating process, a large amount of hydrogen gas is released (U.S. EPA, 1993). This gas entrains chromic acid and forms chromic acid mist at the surface of the chromic acid plating bath. A similar process occurs as the oxygen gas bubbles break free at the liquid surface. Control strategies are needed to prevent the liberated chromic acid mist from entering the plating room environment, and to remove the entrained chromium from the exhaust air prior to discharge from the stack tip.

Companies that perform hard chromium plating use various methods for control and compliance. Two popular strategies have evolved. In the first, chemicals are added to the plating bath to reduce the amount of misting that takes place at the liquid's surface. In the second, the misting at the surface is uninhibited, then the entrained chromium is extracted from the exhaust air stream prior to discharge at the stack tip. A third strategy, used less extensively, involves the use of a special tank hood or cover that contains the mist while allowing other gasses to vent.

4 EARLY DEVICES

Historically, many types of control devices have been used in hard chrome plating applications, with varying degrees of success. Prior to state and local air laws governing the release of airborne chromium, many shops did not have local exhaust ventilation systems attached to individual hard chrome plating tanks. Chromic acid mist simply entered the plating room environment, just like the other process fumes. Often, wall fans were used to evacuate the fumes outdoors, resulting in improved conditions in the shop at the expense of the outdoor environment.

The use of local exhaust ventilation systems on hard chrome plating tanks improved the indoor air quality. Exhaust hoods, fitted to each tank, served to capture most of the chromic acid mist, rather than allowing it to enter the ambient atmosphere of the building. Often, the air was vented directly outdoors.

The earliest use of chromium extraction devices served to reduce the nuisance associated with chromic acid. In addition, chromic acid is a strong oxidizing acid that can cause unwanted etching. It also has a propensity for staining items to a dark red hue; a trait that led to its use for pigmentation by other industries. However, to prevent the landscape surrounding a chrome stack from obtaining the red appearance, and to prevent damage to objects such as automobile finishes, devices were developed to extract some of the chromic acid mist from the exhaust air. This practice became more prevalent as health risks were recognized. Some of these devices are described below.

4.1 Plastic Floating Spheres

Hollow, floating spheres have been used to reduce the amount of misting from the surface of chrome plating tanks. Enough spheres are added to form a layer that is one or two spheres thick. Typical sizes range from 3/4" dia to 2" dia. They are fabricated from plastics that are resistant to chemical attack from chromic acid, such as polypropylene.

During the development work for the MACT standards, EPA examined the use of these floating spheres for air pollution control purposes, and found them to be of limited use. In one such test, a two to three inch layer of 1.5" dia. spheres achieved a removal efficiency of only about 75 percent (Peer Consultants, 1989). This efficiency is too low to meet present discharge limits. The effectiveness of this medium is diminished by the fact that the evolution of hydrogen gas at the workpiece tends to push the spheres away, exposing a portion of the plating bath liquid to the air above.

Furthermore, floating spheres will not reduce overall stack emissions when used in combination with a mesh pad mist eliminator. This is due to the fact that mesh pad devices act more like "constant output" devices rather than "constant efficiency" devices and consequently will not achieve higher removal efficiencies when subjected to a heavy inlet loading.

4.2 Vertical moisture extractors

Vertical moisture extractors use centrifugal force to remove entrained chromic acid mist from a vertical exhaust air stream. The units utilize a radial array of angled, stationary blades. As the air stream passes through these stators, a cyclonic flow is induced that can fling the larger and heavier droplets onto the inner walls of the

device's housing. Typically, these units have a spray down system to clean and recover the chromium.

Vertical extractors (see Figure 1) are no longer used in chromium applications due to the tendency that a significant percentage of the smaller particle sizes will pass through the device, exceeding the discharge limits of modern air regulations and standards.

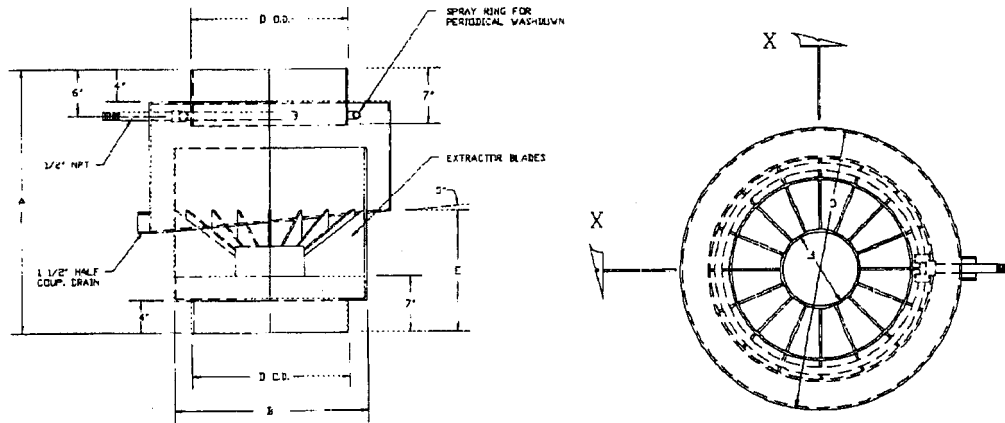

Figure 1: Vertical Moisture Extractor (Source: Midwest Air Products Co., Inc.)

4.3 Chevron-blade mist eliminators

Blade-type mist eliminators have been used successfully to remove chromic acid droplets from horizontal air streams. Prior to EPA's proposal (1993) for the chromium National Emission Standards for Hazardous Air Pollutants (NESHAP), use of blade-type mist eliminators was second only to packed-bed scrubbers; appearing in approximately 30 percent of the hard chrome plating shops (Cushnie, 1994). A series of parallel "zig-zag" blades (see Figure 2) are positioned in the body or housing of the device, in order to direct the air flow through narrow passageways that repeatedly change its direction by approximately 30 degrees. At regular intervals, the extruded blades have narrow vertical channels which serve to capture some of the chromium droplets by inertial forces. Since the channels are oriented in a vertical plane, condensed chrome is transported to a drain at the bottom of the housing. Common blade designs are the overlapping and sinusoidal wave designs (U.S. EPA, 1993).

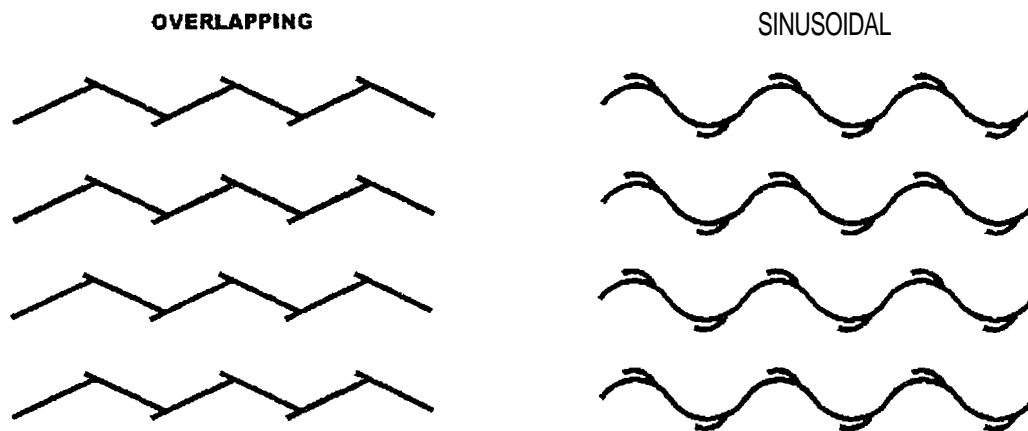

Figure 2: Blade Configurations Used in Chevron Mist Eliminators

Blade-type horizontal mist eliminators have demonstrated a wide efficiency range, as evidenced by EPA tests conducted as background work for the chromium NESHAP. Removal efficiencies ranged from 83.1 to 98.7 percent (U.S. EPA, 1993). Some of the factors influencing efficiency were: gas velocity, blade spacing, seal integrity and wash down frequency.

4.4 Early-generation packed-bed scrubbers

Prior to the promulgation of EPA's MACT standards, packed-bed scrubbers (often called "wet-packed" scrubbers) were used frequently in hard chrome plating applications, serving as the mainstay device for approximately 40 percent of the shops (Cushnie, 1994). Wet scrubbers operate by transferring chromium that is entrained in the exhaust air stream to wetted packing media, and finally to a volume of recirculated fluid.

The exhaust air, laden with chromic acid droplets, passes through a packed-bed section. The bed, filled with plastic media of various sizes and shapes, is continuously wetted by nozzles with scrubbing "liquor" from a recirculation reservoir. This reservoir may take the form of an internal sump. However, remote tanks are often placed indoors if the scrubber is sited outdoors, as a means to prevent freeze-up in colder climates. The media provides a large, wetted surface area where chromic acid droplets are removed from the exhaust air by impingement, and then by dissolution into the scrubbing liquor. A dewatering or demisting stage follows the media bed, and serves to remove excess liquid from the final air stream. Usually, a Chevron-blade mist eliminator section serves the purpose. Adding a second media bed generally improves the removal efficiency of packed-bed scrubbers. An example of a typical horizontal, single packed-bed scrubber appears in Figure 3.

efficiency by improving the drip points and providing larger wetted surface area. Improved spray nozzle systems have also been implemented that result in better distribution of the recirculated scrubbing liquor over the media in the packed bed. Both solid-cone and hollow-cone spray nozzles are used for the task.

Modern scrubbers are available that are sturdier and more durable. Increased wall thickness has reduced the tendency for stress cracking in housings and other critical fabricated plastic components. Better pump selections are offered, which may allow the pumps to run dry and eliminate seal failure. Although the use of blade-type mist eliminator sections are still common, some modern scrubbers have employed meshpad mist eliminator sections in their final demisting stage (Hankinson, 1997). Packed-bed scrubbers are sized to meet the air volume and emission requirements of the vented tanks. Air volume is usually calculated according to American Conference of Governmental Industrial Hygienists (ACGIH, 1992) or Occupational Safety and Health guidelines (OSHA, 1991). The type and depth of packing is usually configured to meet emission limits.

When in contact with acid fumes, packed-bed scrubbers typically operate by the absorption of gaseous components into the liquid phase of the recirculated liquor. In the case of chromic acid, impingement and dissolution occur as the tiny droplets of liquid impact and are dissolved into the scrubbing liquor at the wetted packing and nozzle sprays. During the plating and air pollution control processes, chromic acid is transferred from exhaust air to the scrubbing liquor. If the concentration becomes excessive, performance of the device may diminish, with the resultant increase in emissions. Also, plugging of the media or spray nozzle system may occur. To prevent this condition, most scrubbers purge a portion of the liquor periodically, and replace it with clean water. If the scrubber is not common to other processes that would introduce foreign chemicals, the purged liquid can be reclaimed to the hard chrome plating tanks to replace evaporated water vapor. Typically, chromium-bearing fluid from shared-process scrubbers is either sent to the facility's waste pretreatment system or manifested as hazardous waste. Thus, packed-bed scrubbers often have the disadvantage of generating liquid waste when solving an air pollution problem.

Owners/operators of hard chrome plating tanks using packed-bed scrubbers to control emissions must perform various monitoring tasks to satisfy the provisions of EPA's MACT standards. These monitoring requirements are summarized in Table 2 (U.S. EPA, 1995 b). In particular, the velocity pressure at the inlet of the scrubber, as well as the air pressure differential across the scrubber, must be recorded each day. In order to be in compliance, the scrubber must be operated at a velocity pressure within 10 percent of the value recorded during the initial stack performance test. As an alternative to the 10 percent velocity performance differential, EPA will allow a facility to conduct multiple stack tests to establish a range of emission values within the established standards. Velocity pressure readings serve as an indication that air velocity and volume remain relatively constant as the unit ages. The mass transfer rate and efficiency of packed-bed scrubbers is dependent upon air speed through the bed. Velocity pressure may be measured using an S-type pitot tube installed in the air stream, coupled to an air pressure instrument, such as an inclined manometer. Measuring the pressure drop across the scrubber helps to verify that the packing and mist eliminator stages are not open, dislodged or plugged. Pressure drop readings are easily obtained by piping the low and high pressure ports of an air pressure differential gauge to pressure taps located before and after the scrubber (U.S. EPA, 1995 a).

Performance data for modern packed-bed scrubbers in hard chrome plating applications are difficult to acquire. EPA discontinued its testing prior to the 1993 proposal date for its MACT standards. Since then, nearly all vendors of air pollution control systems have promoted and installed mesh pad mist eliminator technology instead of the early-generation devices.

Table 2: Monitoring Requirements for Ongoing Compliance

Air Pollution Control Device	Monitored Parameter	Monitoring Frequency
Composite mesh pad system	Pressure drop across system	Daily
Packed-bed scrubber	Pressure drop across system; velocity pressure at system inlet	Daily
Packed-bed scrubber plus composite mesh pad system	Pressure drop across the mesh pad system	Daily
Fiber-bed mist eliminator	Pressure drop across the mist eliminator; pressure drop across the control device located upstream of the fiber bed	Daily

5.2 Mesh pad mist eliminators

Mesh pads are well suited to hard chrome plating applications. In fact, EPA set the 0.015 mg/dscm emission limit for the “large, existing” and “new” categories for hard chrome plating tanks based upon the demonstrated performance of composite mesh pad mist eliminator systems. Particle sizes, as small as 5 μm or 0.2 mils, can be removed (U.S. EPA, 1995 b). Unlike packed-bed scrubbers, mesh pad mist eliminators usually do not utilize fluids during normal air-cleaning operation. Instead, chromic acid droplets are removed from the exhaust air stream by directing it through multiple laminations of woven plastic filament. Except for cleaning, they are normally operated dry.

The ability of a mesh pad mist eliminator to remove entrained chromic acid is influenced by many factors, including: particle or droplet size, air velocity through the packing, filament diameter and orientation and mesh pad depth. Droplets are believed to be extracted from the exhaust gas by two main mechanisms. Inertial impaction occurs as momentum directs the droplet into the fiber, instead of weaving a path around it. Also, the inertia of droplets that weave a path around fibers can direct them into downstream fibers, thus removing them by interception (Power and Schott, 1992).

Mesh pad devices usually have more than one mesh pad and filament type. An effective configuration is to position coarse weaves first to remove the larger droplets, followed by finer (tighter) weaves to extract the smaller particle sizes. High removal efficiency can be accomplished without inducing extraordinary pressure drops or plugging (see Figure 4).

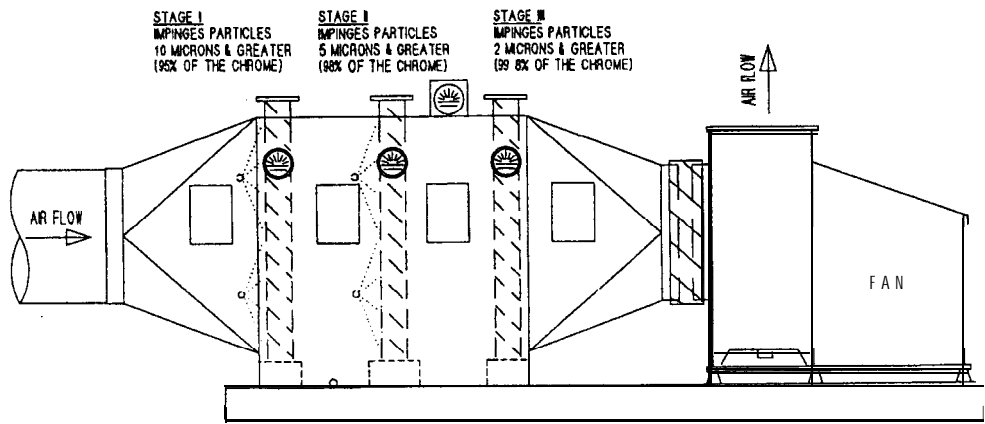

Figure 4: Three Stage Step-Down Composite Mesh Pad System (Source: ScrubAir Vent Systems Inc.)

Similar to wet scrubbers, mesh pad devices are available in both horizontal and vertical airflow designs. Although manufacturers have particular preferences, facility layout at the installation site can be a primary factor for selection. Proponents of the vertical airflow design cite the benefits of using gravitational forces to impede the chromic acid droplets and wash down fluids from penetrating through the pad array to the fan and stack. When final (upper) stages are periodically washed, fluid drains down through dirtier (lower) mesh pads, creating a counterflow rinse effect (Midwest Air Products Company Inc., 1995). During normal, air-cleaning operation, droplets that fall off the bottom side of a pad are reintroduced into a region of similar particles in a process known as reentrainment. Designers and builders of horizontal airflow devices (with mesh pads oriented in a vertical plane) also use gravity to their advantage. Liquid droplets that have been removed from the exhaust air migrate to the bottom of the pads and into a bottom drain assembly, which is used to convey the extracted liquid from the air pollution control device. Entrainment of chromium is minimized due to good drainage (Power and Schott, 1992).

Mesh pads work so effectively for hard chromium plating tanks that vendors and operators have discovered numerous placement options. Some vendors place an initial mesh pad stack in the exhaust hood itself (Midwest Air Products Company, Inc., 1997; ScrubAir Vent Systems, Inc., 1997). This technique has also been described in the literature (Cushnie, 1994) and through responses to an October 1997 on-line inquiry on the National Metal Finishing Resource Center Internet site (<http://www.nmfrc.org>). This practice has the advantage of removing much of the mist right at the plating tank, where it is generated. When used as a prefilter, the hood's pad will reduce the inlet chromium loading of the primary control device downstream. An additional benefit is that the exhaust ductwork remains much cleaner and drier, which minimizes chemical leaks and extends service life.

An alternative approach is to install in-line mesh pad mist eliminators (see Figure 5) after the hoods, but as close as practical to the plating tanks. In this position, they can be used either as stand-alone devices or as a part of a larger air pollution control system (Cushnie, 1994). Whenever possible, these are positioned high enough to permit their drain lines to use a gravity system for returning the recovered fluid to the plating tanks or storage reservoirs. As with the mesh pad hoods, all downstream ductwork stays clean and dry. Often, multiple tanks with different chemical processes are vented to a common, end-of-pipe control device. The

addition of in-line mesh pad mist eliminators in the inlet branch ducting can successfully segregate or isolate chemicals from the common unit, permitting better reuse of recovered fluids. Many of the units available are configured for horizontal air flow, but at least two manufacturers have a vertical design (Met-Pro Corporation, Dual1 Div., 1997; KCH Services Inc., 1997).

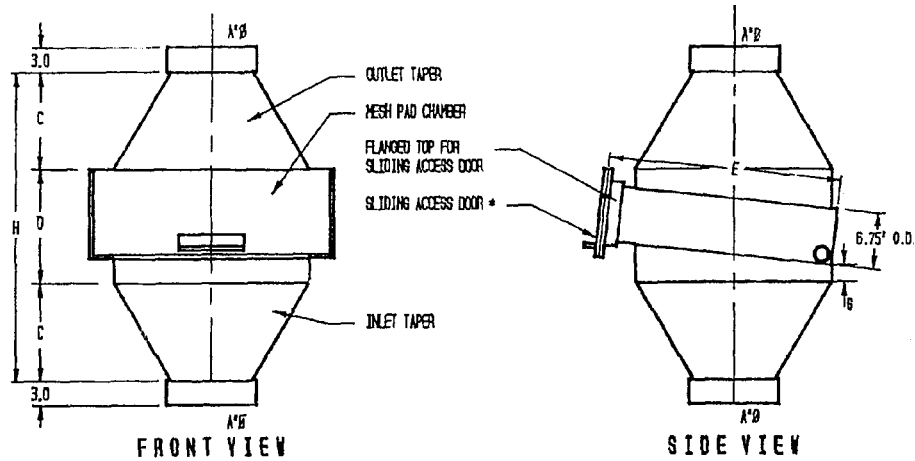

Figure 5: Vertical, In-Line Mesh pad Mist Eliminator (Source: KCH Services, Inc.)

Mesh pads must be removable for periodic immersion cleaning and inspection. Since these in-line devices are normally sited in an elevated location near the plating tanks, the size and weight of the mesh pad cartridges can be a concern. For this reason, the maximum size or capacity of the units is generally limited to about 8,000 to 10,000 cubic feet per minute or less.

For large plating tanks and installations involving multiple plating tanks an end-of-pipe approach is common. Process fumes are ducted from individual tank hoods to a single horizontal or vertical mesh pad unit which may be located in the plating facility or on the roof. These types of units are sometimes referred to as “dry” or “impingement” scrubbers and can range in size from 500 cfm to 60,000 cfm or larger. The vertical airflow designs generally use three or four mesh pads, stacked above each other and employ counter-current spray rinsing schemes. An example of this type of mesh pad is shown in Figure 6.

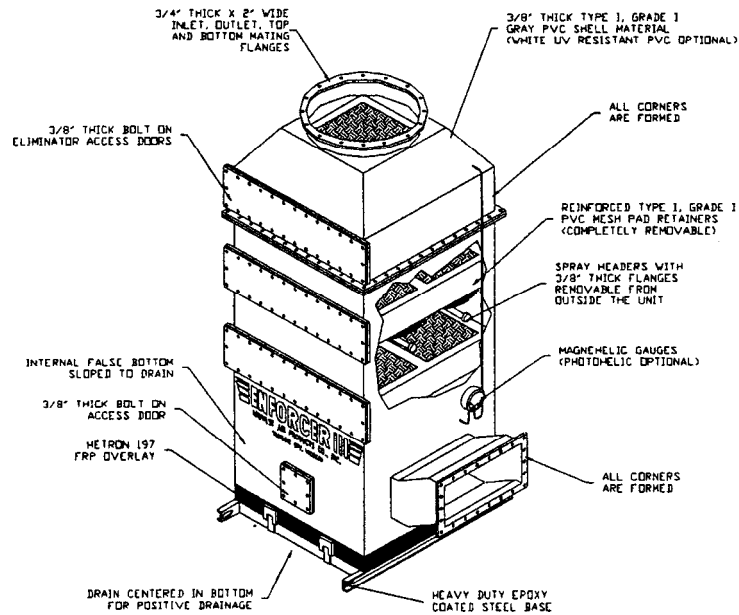

Figure 6: Vertical Mesh pad System (Source: Midwest Air Products Co. Inc.)

At least one manufacturer has designed a horizontal mesh pad mist eliminator system that uses recirculated fluid to assist in capturing the chromium mist during periods of normal plating operation. Spray nozzles inject the fluid into the air stream behind the first mesh pad cartridge, wetting both the air stream and the filaments of the second pad. The smaller droplets that have penetrated through the first dry pad are enlarged by agglomeration, facilitating their removal by the wetted fibers of the second stage (see Figure 7).

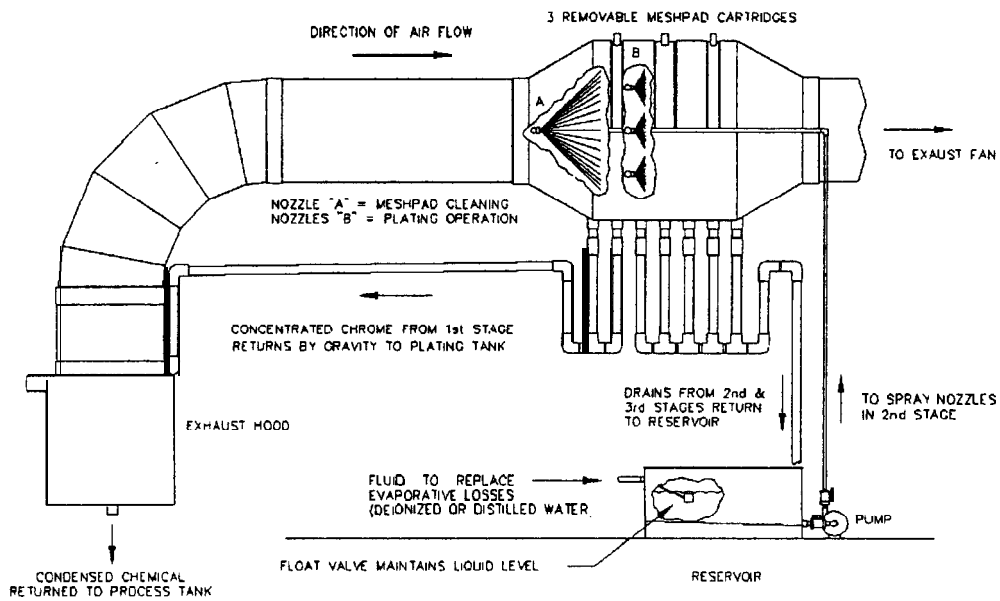

Figure 7: Mesh pad Device with Air-Cleaning Spray Nozzles and Wetted Stage (Source: ChromeTech Inc.)

5.3 Fiber Bed Mist Eliminators

The droplets of chromic acid mist that are generated by the hard chrome plating process vary in size. The largest droplets are easiest to remove, since their size and mass facilitate removal techniques that take advantage of their relatively high momentum. In most hard chrome plating applications, packed-bed scrubbers and mesh pad mist eliminators can routinely meet regulatory discharge limits, even though they allow a small percentage of the entrained droplets to pass through the device. The uncollected chrome usually represents the smaller droplets on the particle size distribution curve.

Certain hard chrome plating applications have a tendency to release more of a finer mist. For instance, the plating of many small parts near the surface of the plating bath can release a finer mist than plating a long hydraulic cylinder in a vertical orientation. In the case of the cylinder, hydrogen gas bubbles that dislodge from the lower regions of the submerged workpiece can agglomerate as they impact and combine with other gas bubbles higher in the bath, creating larger droplets of mist at the surface. Since the small parts are not submerged to an appreciable depth, agglomeration of the gas bubbles is minimized. Another application that may tend to release more of the fine mist would be the horizontal, rotational plating of rotogravure printing cylinders. In addition to the normal gassing from the submerged portion of the roll, it presents a large, wetted area above solution as it is rotated in the hot chromic acid.

Although the removal mechanisms differ, both submicron and larger-sized particles can be efficiently removed by the very fine filaments of a fiber bed mist eliminator. Like the mesh pad devices, larger droplets (greater than 2 microns) are extracted by inertial impaction. However, the fiber beds are able to remove very small particles in a process known as *Brownian motion* or *diffusion* (U.S. EPA OAR, 1991). In this process, the particles collide with gas molecules, causing a portion to be impinged upon the fine fibers (Power and Schott, 1992).

Fiber bed mist eliminators (see Figure 8) are usually constructed in the shape of a vertical cylinder. The filter material is positioned between inner and outer rolled screens to form the filter bed. The collection rate, as well as the pressure drop induced by the filter, is determined by the diameter of the filaments, fiber material and packing density. Exhaust air, laden with chromic acid mist, enters the fiber bed in a horizontal direction, near the bottom of the vertical cylinder. Extracted particles are coalesced into droplets on the fiber surface and drain by gravity through a bottom drain fitting (Ceco Filters Inc., 1997). Like mesh pad devices, fiber beds can suffer from plugging. This can be alleviated by installing a prefilter system, or by positioning the fiber bed downstream of a mesh pad mist eliminator.

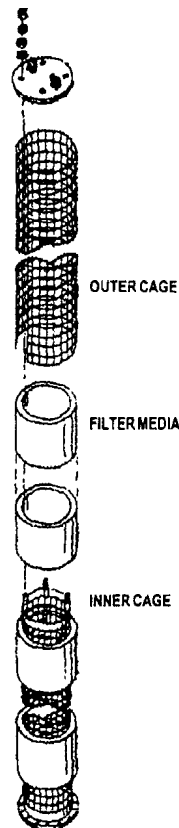

Figure 8: Fiber Bed Construction (Source: Ceco Filters)

5.4 Encapsulating Tank Covers

Some facilities have elected to use a unique product that successfully contains the chromic acid mist beneath an encapsulating lid or cover over the hard chrome plating tank. The system does not require an exhaust stack to vent process air outside of the facility. The hydrogen and oxygen gas, generated during the chromium plating process, pass through a selective membrane system to the plating room environment (Responsible Alternatives Inc., 1997). Water vapor and chromic acid mist do not penetrate the membrane, but will condense within the confines of the tank's cover. At the end of the plating batch, an evacuation cycle removes latent fumes or mists prior to opening the cover for partial retrieval. This approach can reduce the building's energy requirements significantly, since the unit does not exhaust conditioned air outdoors, and there are no large fan motors. An additional benefit is that no chromium-bearing fluids are generated, as with the washdown cycles of mesh pad mist eliminator systems or the recirculated liquor in packed-bed scrubbers.

Due to the fact that water vapor is not removed from the plating bath through surface evaporation, reclaim rinsing strategies and cooling systems may be adversely affected. Also, parts should either have identical start/stop times (i.e., batch plated) or be capable of multiple plating cycles, since all plating in the tank must be stopped before any parts can be added or removed. A diagram of the unit is presented in Figure 9.

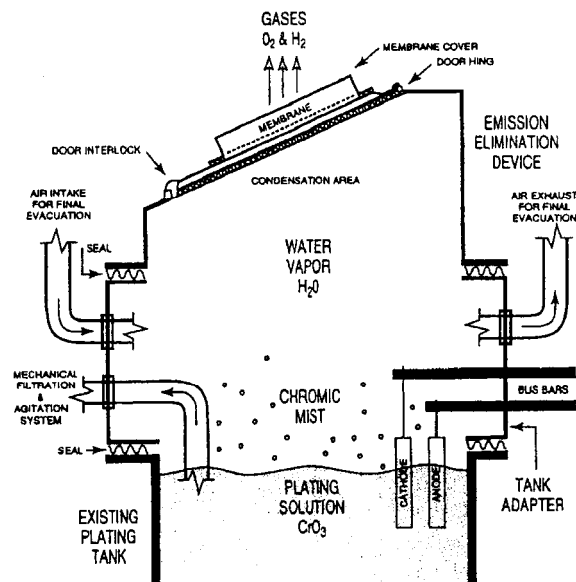

Figure 9: Encapsulating Tank Cover with Membrane and Evacuation Systems (Source: Responsible Alternatives Inc.)

5.5 Combination Systems

Many air pollution control systems are comprised of multiple control devices, arranged in a common exhaust system. Some of the variations include:

- 1) Mesh pads installed in exhaust hoods, followed by an end-of-line mesh pad or packed bed scrubber;
- 2) In-line mesh pad mist eliminators, located after the exhaust hoods, followed by an end-of-line mesh pad or packed bed scrubber;
- 3) Blade-type horizontal mist eliminators followed by an end-of-line mesh pad or packed bed scrubber;
- 4) Mesh pad mist eliminator system followed by an high efficiency particulate air (HEPA) filter as a final polishing device; and
- 5) Mesh pad mist eliminator system followed by a filter bed as a final polishing device.

Some of the advantages in using multiple devices include: segregating chemicals, keeping duct work clean, and reducing the inlet loading on the end-of-line unit. Figures 10 and 11 show two typical combination systems.

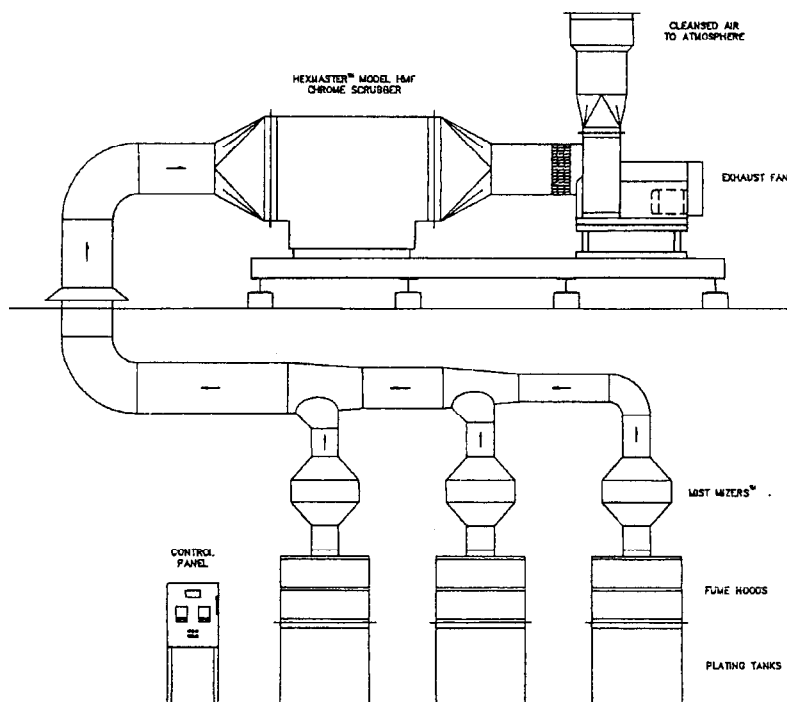

Figure 10: Combination In-Line and End-of-Line Mesh pad Devices (Source: Met-Pro Corporation, Dual I Div.)

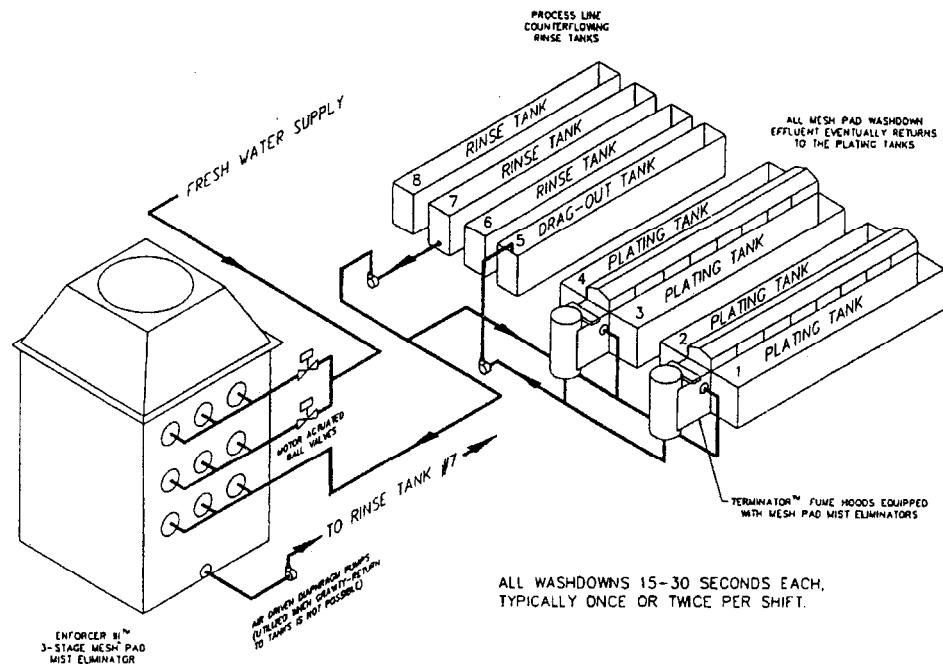

Figure 11: Combination In-Hood and End-of-Line Mesh pad Devices (Source: Midwest Air Products Company, Inc.)

6 DEMONSTRATED PERFORMANCE OF MODERN DEVICES

6.1 Removal Efficiency

EPA and the states regulate the controlled (outlet) emissions of chromium, but not the efficiency of the control devices used to accomplish the task. Testing to determine efficiency is expensive because simultaneous inlet and outlet testing is needed. Although the removal efficiency of modern devices is rarely measured, several examples were found.

- ▶ A two stage, in-line horizontal mesh pad unit was tested by Midwest Research Institute for U.S. EPA's Common Sense Initiative program (MRI, 1995), and found to have 99.79 percent efficiency. The same test showed a slightly higher efficiency of 99.96 percent for a three stage, horizontal mist eliminator with wetted second stage.
- ▶ In separate testing, a three stage, end-of-line vertical mesh pad unit with counterflow rinsing was found to have an efficiency of 99.96 percent (Midwest Air Products Company, Inc., 1997). Vendors have claimed even higher efficiencies of 99.99 percent (Met-Pro Corporation, Dual1 Div., 1997) and 99.997 percent (KCH Services Inc., 1997) for modern mesh pad systems.

Typical efficiencies of pre-1993 devices have been established by EPA and cited in previous sections

of this report. More recent efficiency data have been obtained from contributing vendors and generally fall in the range of 99.79 to 99.997 percent.

6.2 Controlled Emission Rate

Since EPA's MACT standards prescribe a mandatory, initial performance test, emission rate data from hard chrome plating sources are plentiful. Usually, the test results are expressed in milligrams of chromium per dry standard cubic meter of exhaust air, to agree with the concentration-based emission limits in the chromium regulation. Table 3 reveals typical ranges for controlled emissions of chromium for modern air pollution control systems, as determined by emissions testing. The higher emission numbers generally correspond to early-generation devices. Data was supplied by representative equipment manufacturers,

Table 3 : Controlled Emissions from Modern Control Devices for Hard Chrome Plating

System Configuration	Emission Range (mg Cr/dscm)
Three and four stage horizontal and vertical, end-of-line mesh pad devices, preceded by in-hood and in-line mesh pad units.	0.0001 - 0.0234 ¹
Three and four stage horizontal and vertical, end-of-line mesh pad devices, preceded by in-line mesh pad units.	0.0003 - 0.0029 ²
Three stage horizontal and vertical, end-of-line mesh pad devices, preceded by in-line horizontal or vertical packed-bed or mesh pad units.	0.0005 - 0.0015 ³
Three stage, in-line horizontal mesh pad unit with wetted second stage.	0.0018 - 0.0094 ⁴

Table 3 indicates that modern air pollution control devices can meet EPA's 0.03 mg/dscm and 0.015 dscm discharge limits for hard chromium plating sources. Therefore, systems are often designed for other considerations, such as: spatial limitations, energy and resource conservation, process compatibility and future growth.

¹ Midwest Air Products Co., 1997

² KCH Services Inc., 1997

³ Met-Pro Corporation, Duall Div., 1997

⁴ ChromeTech, Inc., 1997

7 OPERATION & MAINTENANCE

If the high performance levels of air pollution control devices for hard chromium plating are to be sustained over time, owners and operators should adhere to recommended operation and maintenance (O&M) procedures. In order to assure that the devices are kept in good working order, EPA's MACT standards require that operators develop an operation and maintenance plan, perform ongoing compliance monitoring, adhere to work practice standards that are specific to their type of device and satisfy various recordkeeping and reporting requirements (U.S. EPA, 1995 b).

Manufacturers have developed effective O&M procedures for their devices. In order to prevent plugging of mesh pads, these are spray washed at regular intervals to remove the captured chromium from the system. This is accomplished through the use of internal spray nozzle system, provided by the manufacturer as an integral part of the unit. The pad wash cycles can be as frequent as 3-6 times per day, and can last from 1-1/2 to 20 minutes. Depending upon site-specific parameters and variations in manufacturers' products, tap water, purified water and rinse water may be used as the wash fluid. Most mesh pad units can be spray washed without interrupting the plating process. Timers and programmable logic controllers (PLC's) are sometimes added to automate the cleaning cycles. Some manufacturers use timed cycles, but force extra cycles if the mesh pads experience a sustained high air pressure differential across the pads (ChromeTech Inc., 1997; KCH Services Inc., 1997).

Chromium-bearing fluids are generated by these pad wash cycles. The fluid, with its extracted chromium, may be returned to the hard chromium plating tanks to replace evaporated water vapor. This technique is viable if the control device services only chromic acid tanks, and the fluid is not contaminated with foreign chemicals from other vented processes. Otherwise, the fluid may be collected and sent to in-house wastewater pretreatment. **systems** or shipped off-site as a manifested RCRA waste. Sometimes evaporators are used to reduce wastewater volume. The amount of fluid generated will vary with such factors as the size of the control unit, frequency and duration of pad wash cycles.

It is difficult to rely solely on spray nozzle cleaning of the mesh pads for extended time periods. Residue that builds up on the inner laminations of a mesh pad stack can be difficult to remove by daily spray cleaning cycles. As a result, manufacturers often prescribe occasional or as needed immersion cleaning procedures. Mesh pads are removed from the housing of the control device, then submerged in the plating tank, itself (hot chromic acid dissolves thick, chrome build-up very well) and/or rinse water tanks. If the pads will not physically fit in process tanks, a dedicated immersion cleaning tank can be fabricated for the task.

Mesh pads can be plugged by substances other than chromium. For instance, particulate matter from grinding and polishing equipment can foul the pads. The mesh pad device is, inherently, a non-selective filter system that removes any particles larger than its pore size. In this case, alternative cleaning procedures are sometimes used, such as high-pressure, high volume aqueous cleaning (KCH Services Inc., 1996) or immersion cleaning in cleaning solutions like caustic soda, sulfuric or muriatic acids. To prevent contamination of the plating bath, care has to be taken to remove the foreign chemicals from the mesh pad weaves before placing the unit back in service. Also, the cleaning solution will inherit a chromium content, which often impacts its hazardous designation. When mesh pads become plugged with substances other than chrome, replacement is often considered.

Mesh pad plugging can adversely affect the performance of the control device. As some regions of the pads become plugged, air is redirected through remaining open areas at a higher velocity. This increase in air speed can pull chromium mist through the weave, resulting in excess emissions. Failing pad seals or faulty drain systems can also diminish performance.

8 FUME SUPPRESSANTS

This section provides a description of existing information related to hard chrome fume suppressants. The Code of Federal Regulations (40 CFR Part 63) defines a chemical fume (or mist) suppressant as any chemical agent that reduces or suppresses fumes or mists at the surface of an electroplating bath or solution. Chemical fume suppressants are further defined as "surface-active" compounds that can be added directly to a chrome plate acid bath to reduce or control misting. Fume suppressants are classified as being temporary or permanent. Temporary fume suppressants are dissipated mainly by the decomposition of the active chemical components; whereas, permanent fume suppressants are dissipated by drag-out of the solution (U. S. EPA, 1993). There are two basic types of fume suppressants: wetting agents and foam blankets. The difference between foam blankets and wetting agents, is the way in which they reduce emissions. Foam blankets physically suppress the mists produced on the surface of plating baths, while wetting agents lower the surface chemistry of plating baths to reduce misting. These differences are explained further in the following sections.

Fume suppressants (including wetting agents, foam blankets, and combinations of both wetting agents and foam) are manufactured in liquid, powder, or tablet form. Fume suppressants are used widely and effectively in decorative chromium electroplating, chromic acid anodizing operations, and in hard chromium electroplating operations (U.S. EPA, 1993). Chemical fume suppressants inhibit chromium emissions at the source (i.e. the bath) and reduce chromium emissions between 93 and 99 percent, depending on the type of product used (Altmayer, 1996). Some of the main advantages of using chemical fume suppressants include: (1) minimization of plating solution evaporation losses; (2) low cost of chromium emission control; (3) very little energy consumption; and (4) no solid waste generation (Colorado, 1997). Limitations in using chemical fume suppressants include: (1) some fume suppressants have a tendency to aggravate gas pitting and defects in base metals and (2) foam blanket-type fume suppressants can entrap hydrogen gas, which may pose a risk of explosion (Maricopa, 1997). Consequently, the main factor affecting the adequate performance of chemical fume suppressants is the amount of suppressant present in the plating bath. A chromic acid bath using chemical fume suppressants should be monitored routinely.

8.1 FOAM BLANKETS

A foam blanket fume suppressant generates a layer of foam across the surface of a solution when current is applied to that solution. Foam blankets do not prevent the formation of chromic acid mist, rather they trap the mist under a blanket of foam. The foam blanket is formed by agitation produced by the hydrogen and oxygen gas bubbles generated during electroplating (Colorado, 1997). Once formed, the foam blanket is usually maintained at a thickness of 1.3 to 2.5 centimeters (0.5 to 1.0 inches) and

covers the entire surface of the plating bath. The ability of the foam layer to contain mist is greatly reduced if proper thickness is not maintained. If the foam blanket is too thin, it will no longer trap the chromium containing mist. Conversely, a thickness greater than 2.5 centimeters (1.0 inches) will cause hydrogen gas to build up in the foam layer, creating a hydrogen explosion hazard should a spark be generated from the contacting equipment. These problems tend to occur more frequently with higher current densities and longer plating times U.S. EPA 1993).

The characteristics of foam blanket solutions are determined by the surface area of the solution, amount of current applied, and temperature and chromic acid concentration of the plating bath, (e.g. less suppressant is required at lower temperatures). Visual monitoring of the thickness of the foam blanket is the most common method for determining when to add foam blanket solution to the bath. The frequency of adding foam blanket solution, also, depends upon the drag-out rate of the solution and the amount of work being performed in the plating tank. Chemical decomposition, to a greater extent than drag-out, is the primary mechanism for the depletion of foam blankets.

8.2 WETTING AGENTS

A wetting agent fume suppressant (WA/FS) reduces the surface tension of a liquid. When wetting agents lower the surface tension of a plating bath, gases escape at the surface of the solution with a diminished "bursting" effect, causing less mist formation. In essence, a wetting agent reduces bubble size, and smaller bubbles burst with less impact on the surface (Colorado, 1997). The most common types of wetting agents are fluorinated since fluorine adds stability throughout a wide range of operating temperatures, current densities, chromic acid concentrations, and oxidation-reduction reactions. The following profile depicts the evolution of wetting agent type fume suppressants.

The first generation WA/FS were hydrocarbon based with an ionic group at one end, such as kerosene or paraffin oils. The disadvantages of the first generation surfactants outweighed the benefits. The oils were layered on the surface and carried over to the rinse tanks. Health and safety issues included the potential for fire hazard and dermatitis. Hydrocarbon based WA/FS oxidize rapidly to trivalent chromium and insoluble organic compounds that eventually decompose to carbon dioxide. Consequently, frequent reagent additions reduced plating efficiency. Furthermore, trivalent chromium was considered to be a bath contaminant, requiring the plating bath to be dumped more often.

For the second generation WA/FS, the hydrocarbon chain was replaced with a fluorinated or perfluorinated carbon chain. This WA/FS, which was first reported in the chromium plating industry in 1954, was considered to be permanent since it has been found to remain stable in boiling concentrated chromic acid and at the highest oxidizing conditions existing at the anodes. The original second generation WA/FS, although neutral, was operating as a cationic surfactant with the dihydroamine. The amino group was later replaced with the sulfite group that changed the surfactant to an anionic condition. The active ingredients in the second generation WA/FS include: potassium perfluoroalkyl sulfonate, amine perfluoroalkyl sulfonate, potassium perfluoroethyl cyclohexyl sulfonate, and ammonium perfluorohexylethylsulfonate. These WA/FS have a low solubility and when mixed with the fluoride ions in the plating bath, become suspended and cause roughness, porosity and cracking on the chromium plate during hard chrome plating operations.

The third generation WA/FS which were introduced in the late 1980s/early 1990s are also perfluorinated but with higher solubility and lower foaming. Supplemental compounds are not required to keep the solubility low. Active ingredients include: organic fluorosulfonate and tetraethylammonium-

perfluorocetyl sulfonate. Another benefit of the third generation WA/FS is that there appears to be no adverse effects on the chromium plate during hard chrome plating operations. This is due to the fact that salt is not required to reduce the solubility. The salt is one of the additives in the second generation WA/FS that produced the adverse effects in hard chrome plating. The US EPA, Office of Research & Development, National Risk Management Research Laboratory in conjunction with the EPA Common Sense Initiative is conducting extensive quality testing on

third generation fume suppressants and have found no adverse quality problems at the time of this publication, Further testing is being conducted at the time of this publication (Ferguson, 1998).

Figure 12 illustrates how a wetting agent can significantly reduce the surface tension of a plating bath. Plating baths typically have a surface tension of 70 dynes/cm; the addition of 120 grams of wetting agent per 100 liters (1.0 pounds of wetting agent per 100 gallons) of plating solution reduces the surface tension of the bath to approximately 40 dynes/cm. While more wetting agent will lower the surface tension of the plating solution further, a point is reached where further additions will not lower surface tension, significantly. Figure 13 clearly shows that chromic acid emissions are most rapidly reduced at surface tensions below 30 to 40 dynes/cm (U. S.EPA, 1993).

8.3 OPERATION AND MAINTENANCE REQUIREMENTS

To ensure optimum efficiency in controlling emissions from hard chrome electroplating, proper (O&M) procedures should be followed. EPA's MACT standards require operators to develop and follow an O&M plan, In addition, specific work practice standards, record keeping, and reporting requirements need to be followed by operators of hard chrome plating facilities (Colorado, 1997). In general, controlling chromium emissions with fume suppressants is effective if the proper concentration of the suppressant is maintained in the plating bath. Maintenance additions of the fume suppressant can be based on any of three measurements: (1) surface tension of the plating bath; (2) ampere-hours of current; and (3) visual examination. Surface tension of the plating solution can be measured by a stalagmometer or tensiometer (Atotech, 1997). Ultimately, however, the proper O&M procedures for fume suppressants depend on each individual hard chrome facility operator. It is the responsibility of the operator to monitor the plating process and to assure that compliance with chromium emission MACT standards is achieved.

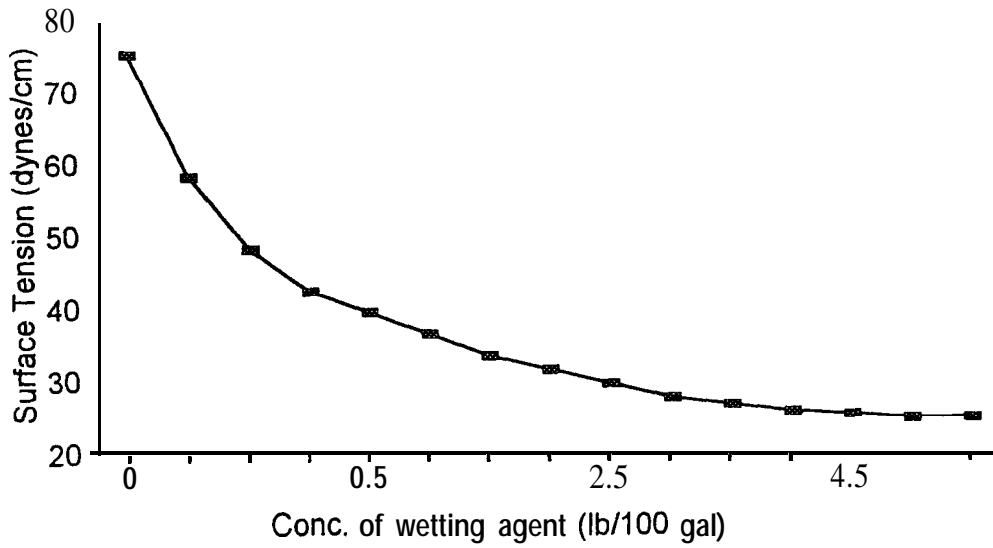

Figure 12: Wetting agent concentration vs. surface tension (USEPA, 1993)

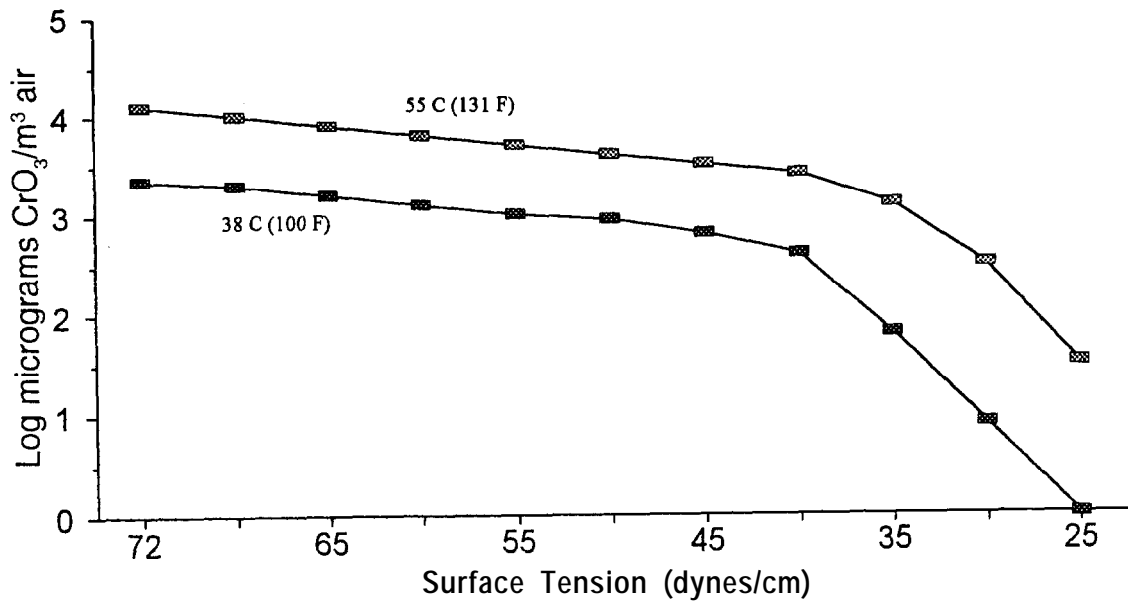

Figure 13: Surface tension vs. chromic acid emissions (USEPA, 1993).

9.0 RESOURCE INFORMATION

In the fall of 1997, a questionnaire was sent out to the membership of the National Metal Finishing Resource Center (NMFRC) asking them to share their experiences with air pollution control devices for hard chrome electroplating. There were twelve responses to the NMFRC on-line inquiry sent through the NMFRC Internet website (<http://www.nmfrc.org>). Twelve respondents were using add-on pollution control measures (i.e. composite mesh-pad system, packed-bed scrubbers, etc.) in addition to chemical fume suppressants in an attempt

Of the twelve respondents to the NMFRC questionnaire using sequential control technologies, three primary control technologies were identified: packed-bed scrubbers, fiber beds and mesh pad mist eliminators.

emissions test for “small, existing” facilities, Some of the disadvantages encountered include: (1) chromium emissions increased under elevated chromic acid concentration in the scrubber liquor; (2) spray nozzles and

using fiber beds, one advantage cited was that this control technology provided extra emissions protection when installed after a composite mesh pad system.

malfunctioning of drain lines. The control technology receiving the most positive response was with the use

Some of the advantages include: (1) low maintenance; (2) cost reduction in reclaimed chromium and (3) mesh pads tend to be dedicated to the tank(s) of origin.

was that mesh pads plugged frequently, even after scheduled spray washdowns.

10 CONCLUSION

Chromium electroplating tanks are a significant source of chromium emissions, The hexavalent and trivalent forms of chromium are toxic and contact with them may cause impaired health. Over 5,000 facilities perform chromium electroplating and/or use anodizing tanks in the United States. Many facilities are considered small shops that are in proximity to residential areas. It is estimated that full compliance with emission regulations will result in a reduction of approximately 173 tons of chromium emitted into the air annually, or approximately a 99 percent reduction from existing levels. The increased awareness of health risks, as well as the subsequent adoption of air quality regulations for hexavalent chromium, has created a need for better air pollution control in the hard chrome plating industry. A partnership of industry, regulatory agencies, and pollution control equipment vendors has resulted in the design and installation of highly efficient devices that can effectively reduce stack emissions. Mesh pad technology has acquired a dominant position for controlling emissions from hard chrome plating tanks. Nearly half (16 of 33) of the NMFRC respondents acknowledged current mesh pad usage, as compared to only 12 percent (4 of 33) currently using packed-bed scrubbers. Of the four scrubber sites identified by the questionnaire, two were located in the United States and both were regulated under the “small, existing” category. Most of the users of air pollution control systems interviewed for the report have adopted mesh pad devices in hard chromium applications. This preference is indicated by the results of performance tests (see Table 3).

Facilities that perform hard chromium plating have a wide selection of alternatives to consider for accomplishing their air pollution control goals. Existing packed-bed scrubbers can achieve the 0.03 mg/dscm limitation for the “small, existing” category of the MACT standards, or when plating tanks generate minimal amounts of chromic acid mist. Facilities that are classified as “large, existing” or “new” can meet the discharge

limit of 0.015 mg/dscm through the use of mesh pad mist eliminator technology. Mesh pads enjoy higher removal efficiencies than the wet scrubbers, and typically generate less chromium-bearing liquids. Combination systems are available that offer additional benefits, such as cleaner ductwork. Adding secondary HEPA filters or fiber bed mist eliminators to a mesh pad system can further reduce emissions. This approach is particularly valuable when the plating tanks generate a high volume of fine chromic acid mist, and when risk-based emission standards are required by state or local regulatory agencies. Companies that elect to use the encapsulating hood system have the potential to save energy while eliminating chromium emissions, altogether. The use of chemical fume suppressants is a major source reduction technique that inhibits chromium emissions at the source. Fume suppressants are being effectively used by job plating shops and facilities to control chromium emissions by up to 99 percent.

For further information please contact:

T. David Ferguson

U.S. EPA

National Risk Management Laboratory

26 West Martin Luther King Drive

Cincinnati, OH 45268

Phone: 513-569-7518 Fax: 513-569-7471

Email: ferguson.david@epamail.epa.gov

REFERENCES:

1. Altmayer, Frank, "Ventilation Considerations For Chromium Plating Tanks," *Plating & Surface Finishing Journal*, pp 42-45, April 1996.
2. American Conference of Governmental Industrial Hygienists, *Industrial Ventilation - A Manual of Recommended Practice*, 2 1st Edition, 1992, pp. 1 O-93 through 1 O-99.
3. Atotech USA, Inc., *General Metal Finishing Products: Informational and Technical Brochures*.
4. Ceco Filters Inc., Ceco Group, Conshohocken PA. "Technical Information on Filter Operation" technical sales sheet, 1997.
5. ChromeTech Inc., "Operation and Maintenance Manual for Trimesh Mist Eliminator", 1997.
6. Colorado Air Pollution Control Division, *Inspector's Guidance Manual, Chapter 1: Electroplating and Anodizing Tanks*, pp 1-102, February 1997.
7. Cushnie, G.C., *Pollution Prevention and Control Technology for Plating Operations*, National Center for Manufacturing Sciences, 1994, Exhibits 3-63 through 3-68, pp. 156-159.
8. Ferguson, D., US EPA, Personal Communication, 1998.

9. Gaddie, Paul G., Southern Graphic Systems, Louisville, Kentucky, E-mail communications, November 1997.
10. Hankinson, KC., "Scrubber Technology: An Update", *Products Finishing*, February 1997, pp. 62, 66
11. Kansas Small Business Environmental Assistance Program (SBEAP), *SBEAP Facts: Chromium MACT Standards*, from Internet website at <http://sbeap.niar.twsu.edu>, pp 1-7, May 1995.
12. KCH Services Inc., "Spectra U Chemical Mist Eliminator - Installation, Operation and Maintenance Instructions", 1996, p. 4.
13. KCH Services Inc., In-Line Series Vertical Mist Eliminator technical sales sheet; additional data submitted in telephone conversations and by facsimile October-November 1997.
14. Lowenheim, F.A., *Electroplating*, McGraw-Hill, New York, NY, 1978, p. 234.
15. Maricopa County Environmental Services Department, *A Guide for Reducing Air Pollution from Chromium Electroplating and Anodizing Tanks*, from Internet website at <http://www.maricopa.gov>, pp 1-3, February 1997.
16. McGean-Rohco, Inc., *ECONO-CHROME STS Fume Suppressant Product Description Brochure*.
17. Met-Pro Corporation, Dual1 Division, *Bulletin 141-Dry Scrubbing Systems*, MistMiser[®] In-Line Mist Eliminator technical sales brochure; additional data submitted in telephone conversations and by facsimile October-November 1997.
18. Midwest Air Products Company Inc., Traverse City, MI, "Enforcer III@ Chromic Acid Removal System" technical sales brochure, *Bulletin 301-A*, April 1995, p. 5; additional data submitted in telephone conversations and by facsimile October-November 1997.
19. Midwest Research Institute, Battelle Memorial Institute Subcontract No. 103639-G002421; *Technical Support to the Hard Chrome Metal Finishing Demo Project - Baseline Testing Report*, December 22, 1995. Table ES-2. Emission Source 3. Unit tested was a Dual-Mesh pad Mist Eliminator (ChromeTech Inc., Windsor, OH).
20. Occupational Safety and Health Administration, 29 CFR § 1910.94, 1990 Revised 1991.
21. Peer Consultants, *Chromium Electroplaters Test Report; Hard Chrome Specialists Inc.; Summary Report*, EPA Contract No. 68-02-4346, EMB Report 89-CEP-15, February 1989, p. 19 and Table 3-5 on p. 21.
22. Plating Resources, Inc., *CANCEL ST-45 Fume Suppressant Product Brochure*.

23. Power, F.B. and Schott, W.M., “Scrubber Designs for Hard Chrome Plating”, *AESF Hard Chromium Plating Workshop*, Jan 30, 1992, p. 96.
24. Responsible Alternatives Inc., Dayton, OH, “Emission Elimination Device” technical sales brochure, 1997.
25. RIN, Inc., *Informational Brochure on Lo-Mist Mist Suppressants for Chrome Solutions*.
26. Sax, Dangerous Properties of Industrial Materials, 5th Ed., Van Nostrand and Reinhold Co
27. ScrubAir Vent Systems Inc., Wauconda, IL; data submitted in telephone conversations and by facsimile October-November 1997.
28. United States Environmental Protection Agency, Emissions Standards Div., Office of Air Quality Planning and Standards, Office of Air and Radiation, *National Air Pollution Control Techniques Advisory Committee*, Minutes of Meeting, January 29-31, 1991; Letter from Steven Taub of Ceko Filters Inc. to Al Vervaert (EPA), pp. 255-256.
29. United States Environmental Protection Agency, *Chromium Emissions from Chromium Electroplating and Chromic Acid Anodizing Operations- Background Information for Proposed Standards*, Volume I, #453/R-93-030a, July 1993, pp. 3-27; 3-28; 4-8; 4-24; 4-33.
30. United States Environmental Protection Agency a, *National Emission Standards for Chromium Emissions From Hard and Decorative Chromium Electroplating and Chromium Anodizing Tanks*; Final Rule published in January 25, 1995 Federal Register, Vol. 60, No. 16, pp. 4948-4993. 40CFR Parts 9 and 63.
31. United States Environmental Protection Agency b, *A Guidebook on How to Comply with the Chromium Electroplating and Anodizing National Emission Standards for Hazardous Air Pollutants*, EPA-453/B-95-001, April 1995, p. 12.
32. United States Environmental Protection Agency (EPA), *Hard Chrome Pollution Prevention Demonstration Project Interim Report*, November 1996.
33. Zitko, Larry, ChromeTech, Inc., Windsor, Ohio, E-mail communications, November 1997.

United States
Environmental Protection Agency
Center for Environmental Research Information
Cincinnati, OH 45268

Please make all necessary changes on the below label,
detach or copy, and return to the address in the upper
left-hand corner.

If you do not wish to receive these reports CHECK HERE ;
detach, or copy this cover, and return to the address in the
upper left-hand corner.

BULK RATE
POSTAGE & FEES PAID
EPA
PERMIT No. G-35

Official Business
Penalty for Private Use
\$300

EPA/625/R-98/002