

An Evaluation of the
Econo-Mist Device

March 1975

Technology Assessment and Evaluation Branch
Emission Control Technology Division
Office of Mobile Source Air Pollution Control
Environmental Protection Agency

Background

The Emission Control Technology Division (ECTD) was contacted by the General Services Administration (GSA) concerning a vapor injection device for use with automobile engines. The device is called the Econo-Mist and is a product of the FAP Corporation of Albuquerque, New Mexico. GSA had received information that the Econo-Mist reduced hydrocarbon and carbon monoxide emissions and increased fuel economy. At the request of GSA, ECTD agreed to test the device. A sample of the device was brought to the EPA laboratory in Ann Arbor, Michigan by FAP Corporation personnel on January 13, 1975.

The Environmental Protection Agency receives information about many devices for which emission reduction or fuel economy improvement claims are made. In some cases, both claims are made for a single device. In most cases, these devices are being recommended or promoted for retrofit to existing vehicles although some represent advanced systems for meeting future standards.

The EPA is interested in evaluating the validity of the claims for all such devices, because of the obvious benefits to the Nation of identifying devices that live up to their claims. For that reason the EPA invites proponents of such devices to provide to the EPA complete technical data on the device's principle of operation, together with test data on the device made by independent laboratories. In those cases in which review by EPA technical staff suggests that the data submitted holds promise of confirming the claims made for the device, confirmatory tests of the device are scheduled at the EPA Emissions Laboratory at Ann Arbor, Michigan. The results of all such confirmatory test projects are set forth in a series of Technology Assessment and Evaluation Reports, of which this report is one.

The conclusions drawn from the EPA confirmatory tests are necessarily of limited applicability. A complete evaluation of the effectiveness of an emission control system in achieving its claimed performance improvements on the many different types of vehicles that are in actual use requires a much larger sample of test vehicles than is economically feasible in the confirmatory test projects conducted by EPA. 1/ For promising devices it is necessary that more extensive test programs be carried out.

1/ See Federal Register 38 FR 11334, 3/27/74, for a description of the test protocols proposed for definitive evaluations of the effectiveness of retrofit devices.

The conclusions from the EPA confirmatory tests can be considered to be quantitatively valid only for the specific type of vehicle used in the EPA confirmatory test program. Although it is reasonable to extrapolate the results from the EPA confirmatory test to other types of vehicles in a directional or qualitative manner, i.e., to suggest that similar results are likely to be achieved on other types of vehicles, tests of the device on such other vehicles would be required to reliably quantify results on other types of vehicles.

In summary, a device that lives up to its claims in the EPA confirmatory test must be further tested according to protocols described in footnote 1/, to quantify its beneficial effects on a broad range of vehicles. A device which when tested by EPA does not meet the claimed results would not appear to be a worthwhile candidate for such further testing from the standpoint of the likelihood of ultimately validating the claims made. However, a definitive quantitative evaluation of its effectiveness on a broad range of vehicle types would equally require further tests in accordance with footnote 1/.

Device Description

The Econo-Mist device is a vacuum vapor induction system which attaches to the Positive Crankcase Ventilation (PCV) line of an internal combustion engine. A mixture of water and methanol of approximately 2.5 parts water to 1 part methanol is contained in a glass bottle which can be attached by means of a bracket to a wall in the engine compartment. A hose and fitting are supplied so that a connection between the bottle and the PCV line of the engine can be made.

With the device in operation, vacuum from the engine pulls ambient air through a small orifice in the cap of the bottle and down through a tube which is immersed in the liquid. At the bottom of the bottle the air is released through small holes and bubbles up through the liquid. The resulting vapor is drawn through the vacuum hose which is connected to the cap of the bottle, through the PCV line, and into the engine induction system to be mixed with the fuel and air mixture.

An illustration of the device is on the following page. The device tested has one difference from the figure; in place of the screw (29) for adjusting air flow, the device has a fixed orifice of .022 inch diameter in the top of the cap. FAP Corporation personnel stated that this fixed orifice size gives satisfactory air flow for all vehicles. When the device was installed on the EPA test vehicles they agreed that it was performing satisfactorily, having made a visual inspection of the bubbling occurring within the bottle.

ECONO-MIST

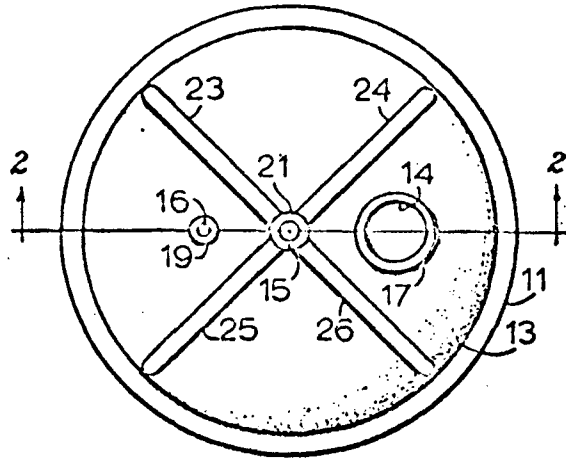

Fig. 1

To PCV Line ←

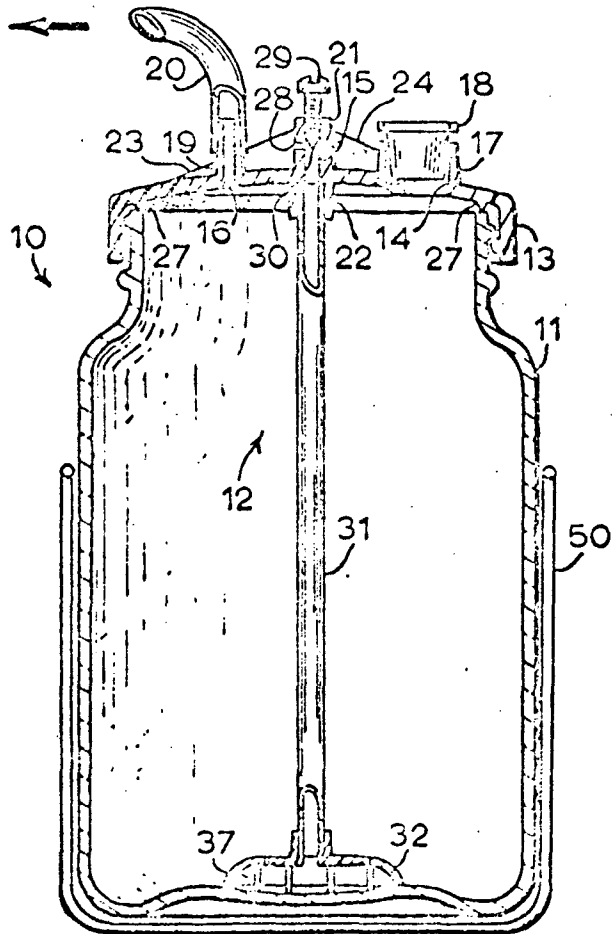

Fig. 2

One gallon of fluid reportedly lasts for about 4000 miles of vehicle travel. For the vehicle tested this would mean that of the total volume of liquid entering the engine, the methanol and water mixture contributes only about 0.6 percent.

The device was installed by EPA with representatives from FAP Corporation observing. Installation took about 20 minutes.

Test Procedure

Exhaust emissions tests were conducted according to the 1975 Federal Test Procedure ('75 FTP), described in the Federal Register of November 15, 1972. Additional tests included the EPA Highway Cycle. All tests were conducted using an inertia weight of 3000 pounds (1361 kg) with a road load setting of 10.3 horsepower (7.68 kW) at 50 miles per hour (80.5 km/hr). A 1970 Plymouth Valiant from the EPA test fleet was used for the test program. A complete description of this vehicle is given on a following page.

The vehicle was tested in three different configurations, first at the baseline condition, second with the device installed, and third with the device connected but the bottle of fluid empty. This last condition was run in order to distinguish the effects of the vapor induction from the enleanment effect of simply increasing the air-fuel ratio.

Before the test program began, the vehicle was tuned to the manufacturer's specifications. The carburetor idle mixture adjustment was set to about 0.15% idle CO. This was a setting at which the vehicle had previously shown good driveability and fuel economy and which corresponds to the way a good mechanic would tune the vehicle. No adjustments were made after the device was installed; the idle CO did not noticeably change, even though additional air was entering the engine due to the device, and driveability remained good.

A schedule of the tests run is given below.

1. Baseline tests without device (2 FTP's and 2 Highway Cycles).
2. Baseline tests with device installed and 25 miles accumulated on system (2 FTP's and 2 Highway Cycles).
3. Tests with device installed and more than 300 accumulated miles on system (3 FTP's and 2 Highway Cycles).
4. Tests with device installed but bottle empty of fluid and more than 300 accumulated miles in this configuration (2 FTP's and 2 Highway Cycles).

TEST VEHICLE DESCRIPTION

Chassis model year/make - 1970 Plymouth Valiant
 Emission control system - Engine Modification

Engine

type 4 stroke Otto Cycle, OHV, in-line 6 cyl.
 bore x stroke 3.40 x 4.12 in./86.36 x 104.78 mm
 displacement 225 CID/3688
 compression ratio 8.4:1
 maximum power @ rpm 145 hp/108 kW @ 4000 rpm
 fuel metering 1-V carburetor
 fuel requirement 94 RON gasoline

Drive Train

transmission type 3 speed automatic
 final drive ratio 2.76:1

Chassis

type unitized construction, front engine,
 rear wheel drive
 tire size FR 78-14
 curb weight 2920 lbs/1325 kg
 inertia weight 3000 lbs
 passenger capacity 5

Emission Control System

basic type positive crankcase ventilation, engine
 modification

mileage on vehicle at start of test program: 17,850

Test Results

Exhaust emissions data summarized below illustrate that the EPA test vehicle, when fitted with the Econo-Mist device and with 300 miles accumulated with the device installed, achieved reductions in HC and CO emissions of 12% and 24% respectively and an increase in fuel economy of 7%. NOx emissions increased by 1%. Accumulating 300 miles in the system did not significantly change either emissions or fuel economy compared to results when the device was initially installed. When the fluid was emptied and only air was being bled to the engine through the device, the emissions and fuel economy remained essentially the same as they were with the fluid.

'75 FTP Composite Mass Emissions
grams per mile
(grams per kilometre)

	<u>HC</u>	<u>CO</u>	<u>NOx</u>	<u>Fuel Economy</u> (Fuel Consumption)
Baseline - Avg. of 2 tests	1.82 (1.13)	12.0 (7.44)	5.93 (3.68)	20.0 miles/gal (11.8 litres/100 km)
Device at low mileage - avg. of 2 tests	1.56 (.97)	9.52 (5.90)	6.02 (3.73)	21.5 miles/gal (10.9 litres/100 km)
Device with 300 miles - avg. of 3 tests	1.60 (.99)	9.13 (5.66)	6.01 (3.73)	21.1 miles/gal (11.1 litres/100 km)
Device with no fluid and 300 miles - avg. of 2 tests	1.60 (.99)	9.43 (5.85)	5.96 (3.70)	20.7 miles/gal (11.4 litres/100 km)

On the EPA Highway Cycle, the Econo-Mist device had the effect of decreasing HC, CO, and NOx emissions by 2%, 19%, and 3% respectively when the device had accumulated 300 miles. Fuel economy increased by 2%. When the fluid was emptied the emissions and fuel economy remained essentially the same.

Highway Cycle Mass Emissions
grams per mile
(grams per kilometre)

	<u>HC</u>	<u>CO</u>	<u>NOx</u>	<u>Fuel Economy</u> (Fuel Consumption)
Baseline - avg. of 2 tests	.93 (.58)	2.31 (1.43)	6.88 (4.27)	27.8 miles/gal (8.5 litres/100 km)
Device at low mileage - avg. of 2 tests	.87 (.54)	2.09 (1.30)	6.63 (4.11)	28.9 miles/gal (8.1 litres/100 km)
Device with 300 miles - avg. of 2 tests	.91 (.56)	1.87 (1.16)	6.67 (4.14)	28.3 miles/gal (8.3 litres/100 km)
Device with no fluid and 300 miles - avg. of 2 tests	.97 (.60)	2.17 (1.35)	7.24 (4.49)	28.2 miles/gal (8.3 litres/100 km)

Conclusions

The changes in emission and fuel economy which were noted on the test vehicle are attributed to the enleanment effect of the Econo-Mist device and might be matched by bleeding more air to the carburetor. This could be accomplished by leaning out the idle mixture and/or the primary jets, or increasing the flow through the PCV line.

Accumulating over 300 miles on the device did not yield any improvements compared to the results when the device was initially installed.

Appendix

Table I

'75 FTP Composite Results
 Mass Emissions, grams per mile
 Fuel Economy, miles per gallon

<u>Test Type</u>	<u>HC</u>	<u>CO</u>	<u>CO₂</u>	<u>NOx</u>	<u>Fuel Economy</u>
Baselines (no device)	1.89	13.5	422	5.54	19.8
	1.76	10.4	419	6.32	20.1
Device Baselines	1.61	9.33	397	6.54	21.3
	1.52	9.72	389	5.49	21.7
Device with 300 miles	1.64	9.57	396	5.54	21.3
	1.50	6.82	410	6.08	20.8
	1.67	11.0	398	6.41	21.1
Device with no fluid	1.55	8.45	404	5.33	21.0
	1.65	10.4	411	6.58	20.5

Table II

'75 FTP Individual Bag Results
 Mass Emissions, grams per mile
 Fuel Economy, miles per gallon

Test Type	Bag 1 Cold Transient					Bag 2 Hot Stabilized					Bag 3 Hot Transient				
	HC	CO	CO ₂	NOx	Fuel Economy	HC	CO	CO ₂	NOx	Fuel Economy	HC	CO	CO ₂	NOx	Fuel Economy
Baselines (no device)	3.21	53.9	433	6.28	16.8	1.42	2.11	432	4.80	20.2	1.79	4.71	393	6.41	21.8
	2.54	38.5	423	7.22	18.1	1.36	2.03	432	5.33	20.2	1.94	5.19	390	7.53	22.0
Device Baselines	2.43	36.3	412	7.65	18.6	1.28	1.80	408	5.68	21.4	1.62	3.39	365	7.36	23.6
	2.24	36.1	406	6.35	18.9	1.24	2.56	398	4.69	21.9	1.52	3.47	361	6.36	23.9
Device with 300 miles	2.59	39.1	421	7.07	18.1	1.34	1.21	404	4.50	21.7	1.50	3.28	362	6.39	23.9
	2.15	24.8	421	7.70	19.0	1.31	1.57	422	4.71	20.7	1.37	3.32	381	7.46	22.7
	2.63	41.9	414	7.67	18.2	1.35	2.65	405	5.28	21.5	1.56	3.55	374	7.61	23.1
Device with no fluid	2.29	30.8	422	6.56	18.6	1.24	2.23	424	4.48	20.6	1.59	3.50	351	6.01	24.5
	2.68	38.4	436	7.89	17.6	1.32	2.26	417	5.55	20.9	1.50	4.96	381	7.58	22.5

Table III

EPA Highway Cycle
Emissions Results and Fuel Economy
Mass Emissions, grams per mile
Fuel Economy, miles per gallon

<u>Test Type</u>	<u>HC</u>	<u>CO</u>	<u>CO₂</u>	<u>NOx</u>	<u>mpg</u>
Baselines (no device)	.94	2.28	312.4	7.01	27.8
	.92	2.34	313.0	6.74	27.8
Device Baselines	.89	2.01	296.3	7.09	29.4
	.84	2.17	305.5	6.17	28.5
Device with 300 miles	.90	1.86	305.8	6.23	28.5
	.92	1.87	309.6	7.10	28.1
Device with no fluid	.95	2.05	309.5	6.72	28.1
	.98	2.27	305.5	7.75	28.4