



United States
Environmental Protection
Agency

Office Of Air Quality
Planning And Standards
Research Triangle Park, NC 27711

EPA-452/R-00-007
May 2001
FINAL REPORT

Air

Economic Impact Analysis of Proposed Reinforced Plastics NESHAP

Final Report



**Economic Impact Analysis of
Proposed Reinforced Plastics NESHAP**

**U.S. Environmental Protection Agency
Office of Air Quality Planning and Standards
Innovative Strategies and Economics Group, MD-15
Research Triangle Park, NC 27711**

Prepared Under Contract By:

**Research Triangle Institute
Center for Economics Research
Research Triangle Park, NC 27711**

May 2001

This report contains portions of the economic impact analysis report that are related to the industry profile.

SECTION 2

INDUSTRY PROFILE

Plastics are one of the most used materials in U.S. industrial and commercial activities and contribute to virtually all products consumed from packaging to motor vehicles. Plastics can be divided into two major groups by resin type: thermoset or thermoplastic. When additional strength is required, many plastics can be reinforced with structural materials to produce RPCs.

In the production of RPCs, polymers and reinforcing materials can be compounded with a variety of fillers to minimize resin requirements and additives that change the physical properties of the desired composite. The polymer is most often a thermosetting resin and the typical reinforcement is glass fiber. Compounding consists of mixing these various materials (sometimes in several stages) and reforming the homogeneous mass into a usable form such as pellets, flakes, or sheets for processing into the final product. A wide variety of RPC processes have evolved to facilitate efficient production of many different types of composites with different physical properties. The fundamental characteristics of the resulting composites include lightweight, high strength-to-weight ratio, nonconductivity, various degrees of corrosion-resistance, and dimensional stability.

In 1997, 3.4 billion pounds of RPCs were consumed in the United States. The RPC market is divided into a number of segments according to its end use. The market segments include general aviation, aerospace, appliances, business equipment, construction, consumer goods, corrosion-resistant products, electrical/electronics, marine, and land transportation (e.g., motor vehicles, trucks, buses). The transportation segment was the largest consumer of RPCs with 1,095 million pounds, or 32 percent of the total consumed in 1997. The construction segment followed with 700 million pounds of reinforced plastics consumed in 1997 (SPI, 1998).

Reinforced plastics are used in the production of many different products, as indicated by the involvement of 42 different SIC codes, as Table 2-1 shows. The SIC codes were

Table 2-1. SIC Codes for Potentially Affected Products

| SIC | Definition |
|------------|---|
| 2434 | Wood Kitchen Cabinets |
| 2519 | Household Furniture, NEC |
| 2522 | Office Furniture, Except Wood |
| 2541 | Wood Office and Store Fixtures, Partitions, Shelving, and Lockers |
| 2599 | Furniture and Fixtures, NEC |
| 2821 | Plastics Material and Synthetic Resins, and Nonvulcanizable Elastomers |
| 3082 | Unsupported Plastics Profile Shapes |
| 3083 | Laminated Plastics Plate, Sheet, and Profile Shapes |
| 3084 | Plastics Pipe |
| 3087 | Custom Compounding of Purchased Plastics Resins |
| 3088 | Plastics Plumbing Fixtures |
| 3089 | Plastics Products, NEC |
| 3281 | Cut Stone and Stone Products |
| 3296 | Mineral Wool |
| 3299 | Nonmetallic Mineral Products, NEC |
| 3431 | Enameled Iron and Metal Sanitary Ware |
| 3499 | Fabricated Metal Products, NEC |
| 3531 | Construction Machinery and Equipment |
| 3533 | Oil and Gas Field Machinery and Equipment |
| 3546 | Power-Driven Handtools |
| 3561 | Pumps and Pumping Equipment |
| 3564 | Industrial and Commercial Fans and Blowers and Air Purification Equipment |
| 3589 | Service Industry Machinery, NEC |
| 3612 | Power, Distribution, and Specialty Transformers |
| 3613 | Switchgear and Switchboard Apparatus |
| 3621 | Motors and Generators |
| 3647 | Vehicular Lighting Equipment |
| 3663 | Radio and Television Broadcasting and Communications Equipment |
| 3679 | Electronic Components, NEC |
| 3711 | Motor Vehicles and Passenger Car Bodies |
| 3713 | Truck and Bus Bodies |
| 3714 | Motor Vehicle Parts and Accessories |
| 3715 | Truck Trailers |
| 3716 | Motor Homes |
| 3728 | Aircraft |
| 3743 | Aircraft Parts and Equipment, NEC |
| 3792 | Travel Trailers and Campers |
| 3799 | Transportation Equipment, NEC |
| 3821 | Laboratory Apparatus and Furniture |
| 3949 | Sporting and Athletic Goods, NEC |
| 3993 | Signs and Advertising Specialties |
| 3999 | Manufacturing Industries, NEC |

obtained from the updated 1993 EPA survey and subsequent screening for potentially affected reinforced plastics producers.

The remainder of this section provides a brief introduction to the reinforced plastics industry. Although the reinforced plastics source category includes only thermoset materials, this profile provides a broader picture of the RPC industry. Section 2.1 provides an overview of the RPC production processes, including a description of the major inputs to production and directly affected production processes. Section 2.2 characterizes the resulting reinforced plastics products and presents historical data on their consumption across various end uses. Section 2.3 details the costs of production. Section 2.4 describes uses and consumers of reinforced plastics. Section 2.5 summarizes U.S. production facilities, and Section 2.6 describes the firms that own these facilities.

2.1 Production

The basic stages of production for RPCs are compounding and processing, as Figure 2-1 illustrates. Polymers and reinforcing materials are compounded with a variety of fillers to minimize resin requirements and additives that change the physical properties of the desired composite. The polymer is most often a thermosetting resin such as polyester (unsaturated), vinyl ester, phenolic, or epoxy; however, thermoplastic resins such as nylons and polyolefins are increasingly being utilized. Compounding consists of mixing these various materials (sometimes in several stages) and then reforming the homogeneous mass into a usable form such as pellets, flakes, or sheets for processing into the final product.

Processing involves shaping and/or molding the compounded plastic material into the desired final product. A wide variety of RPC processes have evolved to facilitate efficient production of many different types of composites with different physical properties. RPC production processes can be separated into two broad categories: open molding and closed molding. Open molding refers to processes where the plastic resins, polymers, reinforcements, and other additives are exposed to the air during the shaping and/or curing stages of processing. This category includes such manual contact molding processes as hand lay-up and spray-up, as well as processes with a greater degree of automation, such as centrifugal casting, filament winding, pultrusion, and continuous lamination. Closed molding processes isolate the input materials inside closed molds during the mixing and curing stages. These include more capital-intensive production methods such as match die molding, reaction injection molding, rotational molding, and thermoforming.

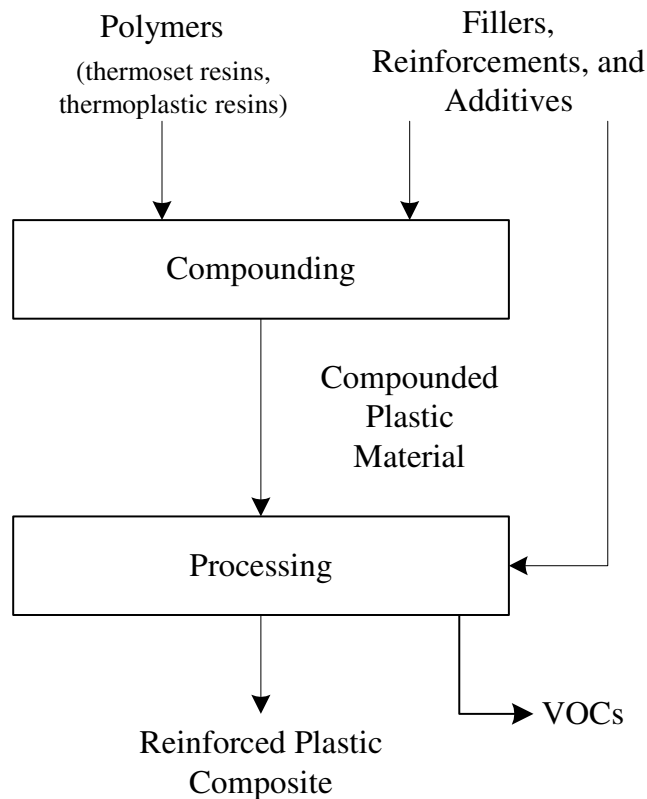

Figure 2-1. Production Flows for Reinforced Plastic Composites

Pollution releases can occur throughout the production processes. Spills of additives and plastic pellets can occur during transport to the facility. Leaks of chemical additives can occur while the additives are being incorporated into the plastic. Volatile organic compounds (VOCs), fugitive emissions, and wastewater discharge are released during the actual processing of the reinforced plastic part. The finishing operations of cleaning can also release VOCs, fugitive emissions, and wastewater discharge (EPA, 1995).

The result of the processing stage is the final part or product referred to as a RPC. RPCs range from small parts for toys or automotive uses to composite structures such as boat hulls, automobile panels, or the fuselage of an aircraft. Thus, some RPCs constitute a final product such as a

bathub or shower stall, whereas others are intermediate products such as panels, pipes, and molding compounds that serve as inputs to manufacturing processes and construction activities.

The remainder of this section describes the manufacture of RPCs in terms of the input materials used, the production processes employed, and the types of products ultimately produced.

2.1.1 Material Inputs

This section describes the different types of plastic resins, reinforcements, fillers, and additives that are most commonly used in the production of RPCs. It includes a discussion of both thermoset and thermoplastic materials; however, EPA's RPC source category only includes thermoset materials.

2.1.1.1 Plastic Resins

There are two broad categories of plastic resins: thermoplastics and thermosets. Thermoplastic resins become soft when heated and may be shaped or molded while in a heated semi-fluid state. Once the thermoplastic resin is molded to the proper state, it is cooled until hardened. In contrast, thermoset resins are usually liquids or low melting point solids in their initial form. When used to produce finished goods, these thermosetting resins are "cured" by the use of a catalyst, heat, or a combination of the two. Once cured, thermoset resins cannot be converted back to their original liquid form. Unlike thermoplastic resins, cured thermosets will not melt and flow when heated and once formed they cannot be reshaped.

Thermoplastics have certain advantages as substitutes for thermoset resins. Thermoplastics have faster processing than thermosets because there is no curing necessary; they have low toxicity and can be remelted and recycled. Improvements in thermoplastic resins over the past 20 years have increased the advantages over thermoset resins. Thermoplastics have high delamination, chemical, and damage resistance, and low moisture absorption (Berglund, 1998). The damage resistance of thermoplastics is due to high impact strength and fracture resistance. Thermosets have better resistance to matrix microcracking in the composite laminate, while thermoplastics have higher strains to failure (Schwartz, 1997). Differences in the characteristics and strengths between thermosets and thermoplastics lead to less than perfect substitution and a gradual increase in the use of thermoplastics for reinforced plastics. Thermoplastics' share of all resins used for reinforced plastics increased by 1 percent from 1991 to 1993.

From 1991 to 1993, thermoset and thermoplastic use for reinforced plastics increased, with thermosets accounting for consistently more than twice the quantity of thermoplastics, as Table 2-2 shows. These figures include the weight of resins, reinforcements, and fillers. Thermoset unsaturated polyesters accounted for roughly 60 percent of the total reinforced plastics shipped during each of these years. Other thermosets, mainly epoxies and phenolics, accounted for an additional 7 to 10 percent of total usage. Recent innovations in thermoplastic resin formulation have improved both their performance properties and cost-effectiveness to the point that their use for RPC production is increasing. Thermoplastics are widely used because of their ability to model complex shapes, their ease of fabrication, and their cost-effective performance characteristics. As shown in Table 2-2, polypropylene, thermoplastic polyester, and nylon account for 80 percent of the 848 million pounds of thermoplastic resins used for reinforced plastics in 1993.

The average annual growth rate for unsaturated polyester, the most commonly used thermoset in reinforced plastics, was 8.5 percent for the period 1991 to 1997. Over the same period, the average annual growth rate for polypropylene, the most commonly used thermoplastic in reinforced plastics as of 1993, was 10 percent.

2.1.1.2 Reinforcements

Most reinforcing materials used in RPC production are fibers, rovings, fabrics, or mats. Fiberglass is the most common material used for mats, but they can also be made from asbestos, paper, metals, sisal, nylon, or cotton. Reinforcements are used in four basic forms: (1) premixed compounds in injection molding and extrusion; (2) woven mats in laminates; (3) preformed woven mats in spray-up or press mold processing; and (4) prepregs, which are semi-cured woven mats impregnated with resins. The amount of fiber reinforcement varies by resin and reinforcing fiber (e.g., fiberglass varies from 5 to 45 percent by weight, cloth

from 30 to 70 percent, and carbon and other expensive fibers from 30 to 65 percent) (Rauch, 1991).

Using reinforcing fibers provides the following attributes to composites:

- improved tensile and flexural strength, stiffness, modulus, and impact resistance;
- resistance to crazing and cracking; and
- reduced shrinkage (Rauch, 1991).

The relative improvement in each of these parameters is a function of the type of fiber, amount of fiber, orientation of fiber, fiber surface treatment, and the characteristics of the matrix polymer.

Fiberglass is the most widely used reinforcement for plastics, with carbon the least used, as Table 2-3 shows. Most reinforcement materials were made of inorganic materials, such as fiberglass (roughly 87 percent of all fibrous reinforcements), asbestos (2.9 percent), and carbon and other high performing/high cost fibers (1 percent). Cellulose is the major natural organic used as a reinforcement. It represented about 9 percent of all fibrous reinforcements in 1990. A 1989 EPA ruling that will eventually ban the manufacture, processing, and distribution of most products that contain asbestos, has and will continue to reduce the consumption of asbestos as a reinforcement agent and thereby alter the distribution of reinforcement materials used to make composites (Rauch, 1991).

2.1.1.3 Nonreinforcing Fillers

Nonreinforcing fillers not only reduce the cost of composites but frequently impart performance improvements that might not otherwise be achieved by the reinforcement and resin ingredients alone. Performance enhancements offered by some nonreinforcing fillers include easier processing characteristics; improved mechanical, electrical, thermal, and aesthetic properties; and resistance to shrinkage (Rauch, 1991). Fillers that do not offer performance improvements are sometimes referred to as extenders. In comparison to resin and reinforcements, fillers are the least expensive of the major ingredients. In general, fillers are nonmetallic minerals, metallic powders, and organic materials added in fairly high percentages, usually more than 5 percent in terms of volume, and in some cases several times the weight of the polymer.

As Table 2-4 shows, the majority of nonreinforcing fillers used in reinforced plastics are inorganic, particularly calcium carbonate. In 1990, roughly 4.2 billion pounds of fillers were used in plastics products. Nonmetallic minerals account for 90 percent of the total consumption in 1990; calcium carbonate is the dominant mineral filler, with roughly 3.17 billion pounds used, or 75 percent of all fillers consumed that year. Calcium carbonate is by far the most commonly used mineral filler in RPC production. Kaolin clay offers several advantages including low water absorption, chemical resistance, and improved electrical properties. Some calcined grades of kaolin even offer additional

Table 2.22. Consumption of FRP for Reinforcement by Resin Type: 1991-1993^a

| Plastics Resins Reinforcement | Quantity (10 ⁶ lbs) | | | |
|---|--------------------------------|-----------------------|--------------|--------------|
| | 1991 | (10 ⁶ lbs) | 1992 | 1993 |
| Thermosetting resins Fiberglass | 1,641 | 900 | 1,792 | 1,878 |
| Unsaturated polyesters Cellulose | 1,467 | 90 | 1,552 | 1,613 |
| Epoxies, others Asbestos | 174 | 30 | 240 | 265 |
| Thermoplastic resins and other high performance Carbon | 719 | 10 | 757 | 848 |
| Polypropylene | 205 | 1,030 | 220 | 246 |
| Polyesters | 187 | | 195 | 230 |
| Nylon | 173 | | 183 | 206 |
| Styrenics ^b | 51 | | 51 | 54 |
| Polycarbonate | 65 | | 70 | 73 |
| Other ^c | 38 | | 38 | 39 |
| Reinforced plastics, total | 2,360 | | 2,549 | 2,726 |

^a Reflects weight of resins, fillers, reinforcements, and other additives.

^b Includes SMA, ABS, SAN, etc.

^c Includes modified PPE, PPS, LCP, ketones, etc.

Sources: Society of the Plastics Industry, Inc. *Facts and Figures of the U.S. Plastics Industry*. Washington, DC. September 1994.

Modern Plastics. "Resin Supply: What's in the Pipeline for '93?" January 1993.

Modern Plastics. "Resin Supply: Plotting a Course for Global Supply." January 1994.

reinforcement when added to a matrix of nylon or polyolefin resins (Rauch, 1991).

2.1.1.4 Additives

A wide variety of additives are used in composites to modify materials properties and performance. Although these materials are generally used in relatively low quantities as compared to resins, reinforcements, and fillers, they perform critical functions including air release, color, fire resistance, lubricity, speed curing, static reduction, surface smoothness, thermal conductivity, and others (SPI Composites Institute, 1995).

Table 2-4. Consumption of Nonreinforcing Fillers in Plastics: 1990

| Product | Quantity (10⁶ lbs) |
|------------------------|--|
| Inorganics | |
| Minerals | |
| Calcium carbonate | 3,170 |
| Kaolin | 185 |
| Talc | 145 |
| Mica | 34 |
| Other minerals | 450 |
| Other Inorganic | |
| Glass spheres | 23 |
| Natural | 203 |
| Total | 4,210 |

Source: Rauch Associates Inc. *The Rauch Guide to the U.S. Plastics Industry*. Bridgewater, NJ: 1991. Table 2-7.

Plasticizers are the most common additive to plastics, as Table 2-5 shows. In 1990, roughly 3.5 billion pounds of fillers, were used in plastics products. Plasticizers accounted for 52 percent of additive consumption in 1990 followed by flame retardants and colorants with 19 and 13 percent, respectively. Plasticizers are essential for producing RPCs in some applications.

2.1.2 Production Processes

Application development in the production of composites requires careful selection not only of which materials to use but also of the production process that can combine these inputs into the desired form most efficiently. Table 2-6 provides data on the distribution of the volume of reinforced plastics by process for 1990. In 1990, approximately 2.6 billion pounds of RPCs were shipped from RPC facilities in the United States. Approximately 1.04 billion pounds of RPCs, or 65 percent of the total, were produced using open molding processes. Hand lay-up, spray-up, and continuous lamination processes accounted for about 62 percent of the RPCs produced with open molding processes. Approximately 900 million pounds of RPCs were produced using closed molding processes in 1991. About two-thirds of this total were produced using injection molding processes, with compression

Table 2-5. Consumption of Plastics Additives: 1990

| Additive | Quantity (10 ⁶ lbs) |
|---------------------|-----------------------------------|
| Plasticizers | 1,810 |
| Flame Retardants | 661 |
| Colorants | 456 |
| Impact Modifiers | 160 |
| Lubricants | 112 |
| Stabilizers | 99 |
| Organic Peroxides | 47 |
| Blowing Agents | 14 |
| Antistats | 9 |
| Others ^a | 130 |
| Total | 3,498 |

^a Includes viscosity depressants, mold release agents, surfactants, slip agents, biocides, antiblocking agents and catalysts.

Source: Rauch Associates Inc. *The Rauch Guide to the U.S. Plastics Industry*. Bridgewater, NJ: 1991. Table 2-6.

molding processes accounting for most of the remaining RPCs made using closed molding processes. This section provides a more detailed description of these processes with special attention given to the five processes that contribute most to emissions at RPC facilities. As presented below, these processes can be segregated into open and closed molding categories.

2.1.2.1 Open Molding Processes

Open molding processes can be broken down into those that are simple, with minimal capital requirements, and those that are more heavily automated, with higher tooling, start-up, and other capital costs. Hand lay-up and spray-up are two contact molding processes that fit the first category of open molding processes. These two production processes use the simplest materials, technology, and manufacturing methods and are ideally suited for low-to-medium volume production of larger, more complex structural shapes. Other open molding processes, such as centrifugal and rotational casting,

Table 2-6. Reinforced Plastics Shipments by Production Process: 1990

| Processing Method | Quantity (10 ⁶ lbs) | Share of Total (%) |
|---|-----------------------------------|-----------------------|
| Open molding | 1,674 | 65 |
| Hand lay-up, spray-up and continuous laminating | 1,038 | 40 |
| Filament winding, pultrusion, and centrifugal casting | 636 | 25 |
| Closed molding | 901 | 35 |
| Compression | 360 | 14 |
| Injection | 523 | 20 |
| Other | 18 | 1 |
| Total | 2,575 | 100 |

Source: Rauch Associates Inc. *The Rauch Guide to the U.S. Plastics Industry*. Bridgewater, NJ: 1991.

lamination, filament winding, and pultrusion processes, have much higher start-up capital costs, often in the millions of dollars.

These processes have relatively low labor costs per unit output. Open molding processes typically only are cost-efficient when used in mass production of uniform RPCs because of high capital costs (SPI Composites Institute, 1995). The following sections provide more detailed descriptions of four open molding processes that contribute to hazardous air pollutant (HAP) and VOC emissions at the RPC production facilities—hand lay-up, spray-up, filament winding, and pultrusion (LeFlam and Proctor, 1995).

Hand Lay-Up. Hand lay-up is one of the most common low-to-medium volume RPC production processes. It typically involves manual application of general polyester liquid resins to a reinforcement, such as glass fiber mats or woven roving, that are laid against the smooth surface of an open mold. Serrated rollers or squeegees drawn across the preparation help to release any air that may be entrapped in the reinforcement material. Chemical curing, often induced by a catalyst additive, hardens the resin and reinforcement into a structural form that is exceptionally strong for its weight. The resin offers a uniform matrix for the reinforcing material in much the same way that concrete does when used in conjunction with reinforcing bars made of steel (SPI Composites Institute, 1995).

The mold is the primary piece of equipment necessary for the hand lay-up process, as Figure 2-2 illustrates. Prior to hand lay-up production, the mold (which is often itself a composite) is sprayed with a tinted gel-coat and allowed to partially cure. The gel-coat side of the final product takes on the color of the pigment used to tint the gel-coat and has a smooth surface and decorative finish, much like that provided by a high quality paint. The appearance and texture of the other side is rough and abrasive, unless corrective measures, such as applying a tightly woven sail cloth to the back surface prior to curing, or sanding the back-surface after curing are performed. In most applications of hand lay-up, only a single finished side is required (SPI Composites Institute, 1995).

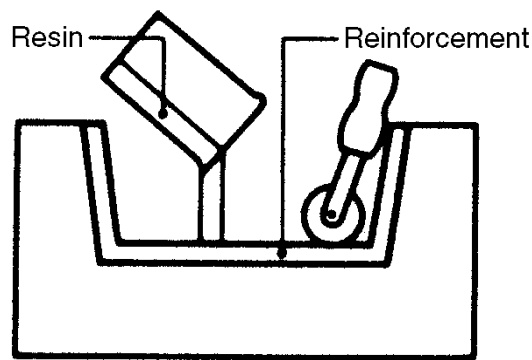

Figure 2-2. Hand Lay-up Processing

Source: SPI Composites Institute. *Introduction to Composites*. Society of the Plastics Industry, Inc. Washington, DC: 1995.

Spray Up. The spray-up process is very similar to hand lay-up processing. It too is best suited to low-to-medium volume production of larger composites with complex shapes. Unsaturated polyesters are also the most commonly used polymer, although isophthaltic polyesters and vinyl esters may also be used. As with hand lay-up, the polymers, reinforcements, fillers, and additives are applied to an open mold that has been sprayed with a pigmented gel-coat and allowed to partially cure.

The primary difference from hand lay-up is that the input materials in the spray-up process are applied to the mold simultaneously, using either an air-atomized or airless spray-up gun. Both types of spray-up guns are designed to automatically chop a continuous feed of glass fiber in lengths ranging from 0.5 to 1.5 inches and then mix both the fiber and a user-determined amount of catalyst into a

fan-shaped spray of polymer or polymer/filler mixture (SPI Composites Institute, 1995). This process is illustrated in Figure 2-3.

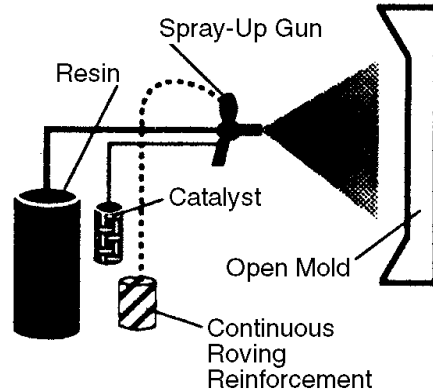

Figure 2-3. Spray-up Processing

Source: SPI Composites Institute. *Introduction to Composites*. Society of the Plastics Industry, Inc. Washington, DC: 1995.

For some applications requiring added structural strength, more fiber reinforcement mats or rovings can be hand laid-up between applications of the sprayed mixture. Rollers or brushes are generally used to remove entrapped air from the mixture after it has been applied to the mold. Twenty-five to 30 pounds of laminate can be applied per minute using some types of spray-up equipment. This speed of application can lessen the labor input requirements relative to hand lay-up but is somewhat offset by the need for a skilled spray-up gun operator to ensure product quality (SPI Composites Institute, 1995).

Filament Winding. Filament winding is a highly automated RPC production process suited to high volume production of strong surface-of-revolution composites, be they open (e.g., springs), cylindrical (e.g., pipes), or closed (e.g., storage tanks and pressure bottles). This process is extremely versatile, offering a wide choice of input materials. Traditional polymer choices have been dominated by thermoset resins (e.g., polyesters, vinyl esters, bisphenol A fumarate resins, furanes, and epoxies), but the use of thermoplastic resins (e.g., nylon, polycarbonates, and acrylic) is under development and gaining popularity. Figure 2-4 offers a simple schematic of a sample filament winding process. The basic steps involve drawing a continuous strand of reinforcing material through a resin bath and then

wrapping the impregnated reinforcement around a revolving mold, called a mandrel. Depending on the shape of the intended RPC, the mandrel can advance in one direction as it rotates (for springs and tubular shapes) or can rotate on two axes (for closed cylinders or spheres) (SPI Composites Institute, 1995).

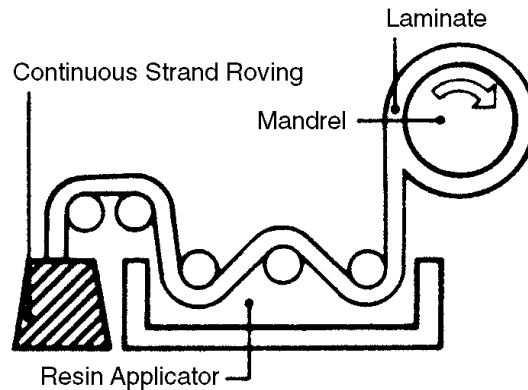

Figure 2-4. Filament Winding

Source: SPI Composites Institute. *Introduction to Composites*. Society of the Plastics Industry, Inc. Washington, DC: 1995.

The most common reinforcement material used is direct processed rovings of glass fiber; however, the choice of reinforcement fibers is virtually unlimited and numerous reinforcement application methods are commonly used. In fact, two or more different reinforcements can be applied in different patterns to a single composite. The ability to vary the type, form, quantity, and orientation of reinforcement materials as filament-wound RPCs are produced allows production designers to optimize the trade-off between input costs and performance requirements of composites intended for a given application. This is because they can limit the use of more costly, higher performance reinforcements to strategic locations in the composite structure and substitute lower cost fibers elsewhere. The use of hybrid reinforcement methods is increasingly common in filament winding processes. Limitations of filament winding include relatively high VOC emissions and capital investment requirements (SPI Composites Institute, 1995).

Pultrusion. The pultrusion process, shown in Figure 2-5, creates profile shapes like rods, plates, beams, and channels by pulling continuous strands of reinforcements through a resin bath, one or more pre-shaping guides, and ultimately through a heated shaping die where the pultruded RPC is

cured into its permanent cross-sectional shape. The last stage in the process is the cutoff where equipment is used to cut the pultruded profile to its intended length. Pulling is achieved using either intermittent or continuous pulling devices. While development is underway to incorporate the use of thermoplastic resins in pultrusion processes, at present most applications are limited to the use of thermoset resins, primarily polyester, but phenolics, epoxies, and esters are also used. Commonly used reinforcement materials include continuous fiber glass rovings, surfacing mats, graphite fibers, chopped and continuous strand mats, and woven tapes (SPI Composites Institute, 1995). Advantages of pultrusion include greater reinforcement orientation, a necessary attribute for some RPC applications, and lower capital equipment costs than most other high-volume RPC production processes. The primary limitations of the process are an inability to vary the cross-sectional characteristics along the length of the pultruded composite and stress resistance that is limited to the direction of the reinforcement material (SPI Composites Institute, 1995).

2.1.2.2 Closed Molding Processes

Closed molding processes, such as the many variants of compression molding, use pre-prepared molding compounds like sheet molding compounds (SMC), bulk molding compounds (BMC), and reinforced thermoplastic sheets as feedstocks to their production processes. These molding compounds are prepared to facilitate mass production of a wide variety of composites, each with its own special physical attributes. These compounds have the advantage of an extended shelf-life. Each compound is produced using fixed proportions of the appropriate polymers, reinforcements, fillers, and other additives needed to impart the specific physical properties and appearance to the composite produced (SPI Composites Institute, 1995). This section provides more detailed descriptions of the most common compression molding processes as well as a closed molding process called injection molding.

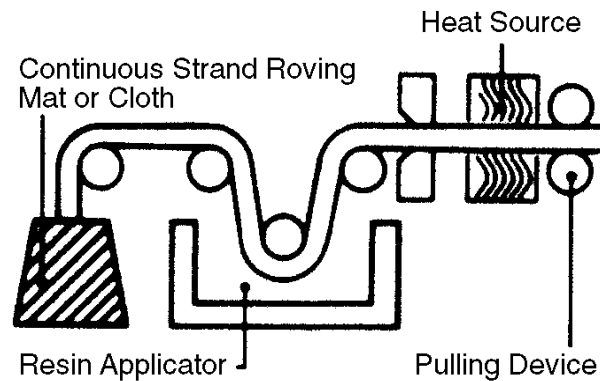

Figure 2-5. Pultrusion

Source: SPI Composites Institute. *Introduction to Composites*. Society of the Plastics Industry, Inc. Washington, DC: 1995.

Compression Molding. There are four primary high-volume RPC production processes commonly called compression molding processes (and many variations of these processes):

- Sheet Molding Compound (SMC),
- Bulk Molding Compound (BMC), including Transfer Molding,
- Wet System Compression Molding, and
- Reinforced Thermoplastic Sheet Compression Molding.

For each of these processes, the chosen composite materials, including all resins, reinforcements, filler, and additives, are compressed into a desired shape in a matched die hydraulic press under pressure ranging from 250 to 3,000 psi (SPI Composites Institute, 1995). The composite feedstock is then held in place while the resin matrix quickly cures into its permanent hardened shape. Significant differences among these processes determine their suitability for a given application. The following sections offer brief descriptions of each of the main high-volume molding processes.

Sheet Molding Compound. SMC is produced by mixing all of the composite materials, except for the reinforcing fibers, into a paste. The paste is then uniformly spread onto two separate “carrier films” that are fed through an SMC machine where the paste is compounded with the reinforcements. The carrier films are held apart, one above the other, while reinforcements, cut from continuous strand rovings, are uniformly distributed on the lower carrier film and then forced together like a fiber reinforcement sandwich as they are fed through a system of rollers that compact and consolidate the SMC. The SMC, with the carrier film still in place, is then rolled up and encased in a nylon sleeve that prevents evaporation of volatiles from the resin matrix that would allow the compound to finish curing. After a period of storage in a climate controlled area, the SMC is thickened to the desired viscosity for its intended application and then taken to a molding press where it is cut to its desired shape. The carrier films are then removed and the SMC permanently compressed into its ultimate shape in a heated matched die mold (SPI Composites Institute, 1995).

SMC molding has high start-up capital costs associated with it. However, while the tooling costs of SMC compression molding are much higher than for most other RPC production processes, they are still generally lower than would be required to produce equally strong shapes from metal inputs. Retooling an SMC process to modify the design of a composite is much quicker than in metal stamp molding operation. Other advantages include the ability to consolidate many parts into a single RPC. These attributes make SMC molding very attractive to such high-volume end users as producers of automobiles, appliances, construction, and electrical product industries. SMC compression molding is used to produce more composites of greater value than any other RPC production process (SPI Composites Institute, 1995).

Bulk Molding Compound. Bulk molding compound, like SMC, is more a material than a process. BMC generally consists of approximately 20 percent reinforcement, 50 percent fillers and additives, and 30 percent resin matrix. The compound can be tinted to a desired color and, through strategic selection of input materials, can be prepared to afford exceptional mechanical and fire retardant properties. The basic process entails combining the desired composite materials into a molding compound that resembles putty and then placing the compound into a compression mold. Molding typically takes place at temperatures between 250 and 350 °F and at pressures ranging from 350 to 2,000 psi (SPI Composites Institute, 1995). BMC is also used in transfer molding and injection molding processes to produce more complex shapes with closer mold tolerances than can be achieved using matched die compression molds.

The advantages of BMC include reduced costs and improved stiffness and fire retardance due to lower reinforcement loadings and increased filler loadings. BMC can also be molded into intricately detailed, precise shapes with inserts affixed during the molding process.

Wet System Compression Molding. Wet system compression molding differs from SMC and BMC compression molding in that a matrix of liquid resin mixed with fillers and additives is pumped or poured onto dry reinforcement mats that have been placed inside of the matched die mold. Thus, unlike SMC and BMC processing, the resin is not introduced to the reinforcements prior to molding. Hydraulic pressure is exerted on the mold, forcing the resin to permeate the reinforcement materials and fixing, and the composite remains under pressure until it has fully cured. Typical curing temperatures are 250 to 350 °F, much like SMC and BMC molding, but the pressure requirements are much lower, in the range of 250 to 1,000 psi (SPI Composites Institute, 1995).

Like SMC and BMC, wet system molding can produce RPCs with two finished surfaces. Other advantages of this process include equipment and tooling savings, due to the reduced pressure requirements, and higher reinforcement loading, which affords superior mechanical properties. The disadvantages of wet system molding include an inability to provide undercuts or reinforcing ribs to add strength to the composite, higher labor costs, and more process waste than is typical with BMC and SMC molding processes.

Reinforced Thermoplastic Sheet Molding. Reinforced thermoplastic sheet molding is quite similar to SMC, in that the composite materials are all combined and shaped into sheets prior to molding, but as the name implies, this process is designed for use with thermoplastic resins. Another difference is that the sheet is cut to fit entirely within the mold and is preheated prior to placement in the mold. When the mold is closed and pressure is applied, the thermoplastic resins start to flow and conform to the shape of the mold. The temperature of the mold is then controlled for 30 to 90 seconds to permit the molded sheet to solidify and permit removal of the RPC from the mold (SPI Composites Institute, 1995). This process is sometimes called stamping, because the mold used is similar to a steel stamping press.

Advantages of this process include unlimited shelf life for the input sheets, fast molding cycles, recyclable scrap, and potential for parts consolidation relative to metals. Capital costs are comparable to SMC molding. There are, as yet, few suppliers of the input sheets because this process is new.

Injection Molding. Injection molding is perhaps the most versatile and widely applied process for mass producing fairly complex composites of absolute dimensional accuracy. It can be used for parts of any size for which a mold can be built and is ideally suited to high-volume applications. Each compression molding machine is capable of producing thousands of detailed RPCs per hour. As illustrated in Figure 2-6, the same equipment can be used to mold both thermoplastic resins and thermoset resins into RPCs. The only difference is the temperature at which the resin is kept during the curing stage of the process within the mold. This process is most commonly used to shape RPCs from thermoplastic resins (e.g., nylon, acetal, PVC, polyethylene, SAN, polycarbonate, and ABS), which require cooler curing temperatures, but compression molding of thermoset resins (e.g., polyester, phenolic, epoxy and urethane) is gaining popularity (SPI Composites Institute, 1995).

The basic steps in the standard injection molding process consist of conveying granular or pelletized thermoplastic resin from a supply hopper to an opening at the opposite end of a heated metal

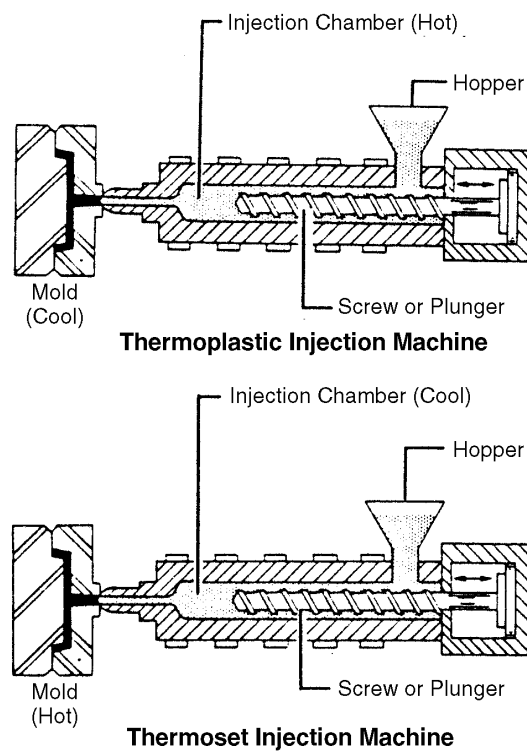

Figure 2-6. Injection Molding

Source: SPI Composites Institute. *Introduction to Composites*. Society of the Plastics Industry, Inc. Washington, DC: 1995.

chamber, using an auger to control the rate that the resin advances to the tip. The resin is thus heated to a semi-fluid state melting or plasticizing the resin and can be injected into the mold at the tip of the chamber with a twist of the auger. The mold is kept at a cool temperature and held closed while the resin cools down and solidifies. Once the resin has solidified, the mold is opened to eject the composite from the mold and the whole process can be restarted.

2.2 Products

There is great diversity in the types of products made using most of these processes. Among the open molding processes, product diversity is especially extensive in the hand lay-up, spray-up, and filament winding processes. Among closed molding processes, product diversity is greatest for the compression and injection molding processes. Table 2-7 describes the basic shape characteristics that are best produced by each RPC production process and lists examples of composite products that result from each process.

2.3 Costs of Production

There are three variable inputs in reinforced plastic production: raw materials, labor, and energy. Raw materials include plastic resins, reinforcing materials, and fillers. Labor and energy are used throughout production as well as for final product transport.

Prices for thermoset resins have increased since 1996, while most thermoplastic prices have fallen over the same period, as Table 2-8 shows. Among thermoset resins, unsaturated polyester and phenolics are close in price, while epoxy has a higher price than both. PVC and polypropylene are the least expensive thermoplastics, while the price of nylon is more than four times greater than these two. Table 2-9 provides prices for fibrous reinforcing materials. For 1997, the price of fiberglass, the most common reinforcement, is approximately \$1.11 per pound. The price of carbon is the most expensive and is primarily used in high performance applications (\$10 to \$30 per pound).

Many producers use fillers in order to minimize the amount of higher-cost resins needed per unit output (see Table 2-9). RPC manufacturers frequently select calcium carbonate because of its relative low cost (\$0.08 per pound). Other popular low cost fillers include kaoline and alumina trihydrate (\$0.05 and \$0.13 per pound respectively). As noted in Section 2.1.1.4, additives are also used in

Table 2-7. Compatibility of RPC Production Processes with Shape Characteristics and Specific Products

| Process | Shape Characteristic | Product Examples |
|--|---|---|
| Open molding processes | | |
| Hand lay-up and spray-up | Large, complex | Boat hulls, auto and truck body parts, swimming pools, tanks, corrosion resistant equipment, furniture, duct work, and equipment housings |
| Filament winding | Round, rigid | Pressure bottles, airplane bodies, underground storage tanks, drive shafts for cars and trucks, sailboat masts, and gun barrels |
| Pultrusion | Uniform cross-section | Corrosion resistant rods, beams, channels, and plates |
| Continuous laminating | Thin, flat, or curved profiles | Flat and corrugated paneling, panels for truck trailers, road signs, and refrigerator liners |
| Centrifugal casting | Uniform wall thickness | Larger pipes, tanks |
| Closed molding processes | | |
| Compression molding | | |
| SMC compression molding | Large or small shapes can be smoothly ribbed, embossed, or high complex | Automotive body panels and front end assemblies, appliances, air conditioner base, office equipment housing |
| BMC compression molding | Smaller complex | Air conditioner components, pump housings, computer components, power tools, motor parts, gear cases, circuit board covers, garbage disposal housings |
| Reinforced thermoplastic sheet molding | Simple, thinwall | Material handling pellets, tray, and shelving; automotive bumper beams, floor pans, battery trays, radiator supports; helmets; flooring; concrete pouring forms; and chair shells |

(continued)

Table 2-7. Compatibility of RPC Production Processes with Shape Characteristics and Specific Products (Continued)

| Process | Shape Characteristic | Product Examples |
|--------------------------------------|---|--|
| Closed molding processes (continued) | | |
| Wet system compression molding | Contoured, medium-wall thickness | Trays, outboard motor shrouds, appliances, automotive applications, and sinks |
| Transfer molding | Simple configurations | Body components for trucks, sports car bodies, automotive body panels, marine parts, small boats, plumbing components, equipment housings, and electrical components |
| Bag molding | Simple, large, contoured | High performance aircraft parts, and aerospace components |
| Reaction injection molding (RIM) | Large, intricate, high performance, solid or cellular | Automobile and truck body panels, bumper beams for cars and trucks, floor pans for cars and trucks, and pick-up truck beds |
| Rotational molding | Hollow bodies, complex | Water pressure tanks, water softener tanks, and filters |

Sources: Rauch Associates Inc. *The Rauch Guide to the U.S. Plastics Industry*. Bridgewater, NJ: 1991.

SPI Composites Institute. *Introduction to Composites*. Society of the Plastics Industry, Inc. Washington, DC: 1995.

Table 2-8. Plastic Resin Prices: 1996-1999

| Resin | Price (\$/lb) | | | |
|------------------------------------|---------------|-----------|-----------|-----------|
| | 1996 | 1997 | 1998 | 1999 |
| Thermosets | | | | |
| Epoxy ^a | 1.25-1.37 | 1.30-1.42 | 1.30-1.42 | 1.30-1.42 |
| Unsaturated Polyester ^a | .73-.84 | .75-.86 | .75-.86 | .75-.86 |
| Phenolic ^a | .72-.82 | .74-.84 | .74-.84 | .74-.84 |
| Thermoplastics | | | | |
| ABS ^b | .96-1.01 | .88-.91 | .68-.71 | .64-.67 |
| Polypropylene ^a | .42-.44 | .39-.41 | .29-.31 | .28-30 |
| Polystyrene ^a | .48-.50 | .38-.40 | .38-.40 | .41-.43 |
| PVC ^a | .39-.40 | .38-.41 | .27-.30 | .29-.32 |
| Nylon ^c | 1.28-1.38 | 1.28-1.38 | 1.39-1.49 | 1.29-1.39 |

^a General purpose.

^b Medium-impact.

^c Type 6.

Source: *Plastics News*. "Resin Pricing." Updated May 13, 1999. As obtained on May 17, 1999. <<http://www.plasticsnews.com>>.

relatively low quantities to enhance particular properties of RPCs . The Agency computed a weighted average price for additives in 1997 of \$0.88 per pound.

2.4 Uses and Consumers of Reinforced Plastics

RPCs are an input into the production of a variety of products ranging from children's toys to aerospace components and bathtubs to boat hulls. Therefore, the demand for RPCs is derived from the demand for these products, which can be found within one of the following major segments of the market for RPCs:

- Aircraft/Military: flight surfaces, cabin interiors, aerospace components, military helmets, armament, rocket launchers.

- Appliances/Business Machines: refrigerators, freezers, ranges, microwave ovens, power tools, small appliances, computer housings, calculators.
- Construction: swimming pools, rain gutters, molds for concrete, bathtubs, shower stalls, whirlpools, spas, highway signs, cooling tower components, paneling for greenhouses, patios, railings and other architectural components.
- Consumer Products: fishing rods, golf clubs, skis, tennis rackets, furniture, campers, snowmobiles, exercise equipment, seating, counter tops, serving trays, boxes and containers, microwave cookware.
- Corrosion Resistant Products: pipe fittings, ducts, hoods, tanks, pumps, filtration equipment, and a wide variety of other chemical resistant products for use in the waste/wastewater treatment, chemical processing, semiconductor, and petrochemical industries.

Table 2-9. Selected Plastic Reinforcement and Filler Prices: 1997

| Input | Price (\$/lb) |
|-----------------------|----------------------|
| Reinforcements | |
| Fiberglass | \$1.11 |
| Cellulose | \$0.52 ^a |
| Carbon | \$10–30 |
| Average | \$1.25 |
| Fillers | |
| Calcium carbonate | \$0.08 ^a |
| Kaolin | \$0.05 ^a |
| Alumina trihydrate | \$0.13 |
| Talc | \$0.30 |
| Mica | \$0.21 ^a |
| Other minerals | \$0.08 ^a |
| Glass spheres | \$0.78 ^a |
| Natural | \$0.05 ^a |
| Average | \$0.09 |
| Additives | |
| Average | \$0.88 |

^a Price computed by dividing value by quantity and adjusting by a producer price index (PPI) where appropriate.

Sources: U.S. Geological Survey. 1997. Minerals Yearbook: Clays. [online] <<http://minerals.usgs.gov/minerals/pubs/commodity/myb>>. Obtained January 21, 2000.

U.S. Geological Survey. 1997. Minerals Yearbook: Mica. [online] <<http://minerals.usgs.gov/minerals/pubs/commodity/myb>>. Obtained January 21, 2000.

Rauch Associates. 1991. *The Rauch Guide to the U.S. Plastics Industry*. Bridgewater, NJ: Rauch Associates, Inc.

Murphy, John. 1994. *The Reinforced Plastics Handbook*. Oxford, UK: Elsevier Advanced Technology.

U.S. Bureau of Labor Statistics. 2000. Producer Price Index—Commodities: WPUSOP9200, Intermediate Materials Less Food and Energy, 1990–2000. [online] <<http://www.bls.gov>>. Obtained January 20, 2000.

Shearer, Brent. April 15, 1996. “Carbon Fibers Adjusting to Changes.” *Chemical Marketing Reporter*.

- Electronic/Electrical: rods, tubes, circuit breaker boxes, molded parts, housings, substation equipment, electronic connections, pole line hardware, microwave antennas, and many other electrical and electronic applications.
- Marine: boat hulls, motor covers, marine docks, moorings, floats, buoys, canoes, kayaks, and other components and hardware for naval, pleasure, and commercial water craft.
- Transportation: body panels for cars, buses, and tractor trailers, truck cabs, boxcar doors, subway seating, heater housings, front end assemblies, drive shafts, wind deflectors, grill opening panels, tail light housings, fender liners, instrument panels, and other diverse parts and accessories for land transportation and utility vehicles.
- Other: all other composites applications. One significant new category of applications the repair/replacement of components of the civil infrastructure. Product examples include: guardrails, sign posts, and structural supports for highways and bridges.

Over time, the need for lightweight structural materials that meet strength, stiffness, and other mechanical property requirements for high performance applications has prompted major developments in production practices in the end-use markets. The characteristics demanded vary by the market (e.g., construction, transportation, consumer goods, or other product manufacturer). For example, the ability to replace an assembly of several metal parts with a single molded composite is very appealing to manufacturers of appliances and transportation equipment. The chemical resistance properties of RPCs allow users in the construction and marine market segments to avoid the higher maintenance costs associated with the metal and wood materials that they traditionally used.

The strength-to-weight ratios for composites are typically greater than those of metals. As an example, phenolic composites have greater yield strengths than steel or aluminum, although resistance to bending and the resistance to elongation may be superior in metals depending on the type of reinforcement in the plastic (Murphy, 1994). Composites have low flammability properties, which make composites superior to wood for applications susceptible to fire. Table 2-10 provides some examples of these desired demand characteristics for selected end uses and associated products.

Table 2-10. Demand for Reinforced Plastic Composites: Some Examples

| End-User Industries and Product Markets | Demand Characteristics | Product Examples |
|--|--|---|
| Aircraft/aerospace/military | Lightweight, moldability, and versatile nature | Structures and interiors of both military and commercial planes |
| Appliances/business equipment | Parts consolidation, design flexibility, and high strength to weight ratios | Dishwasher panels, freezers, small appliances, computer housings, and radios |
| Construction | Corrosion resistance, high strength to weight ratio, custom finishing, longer life-cycle and/or fewer maintenance requirements | Beams, columns, roof trusses, soffit, siding, flooring, bathtubs, sinks, shower stalls, whirlpools and spas |
| Marine | Large, rigid, continuous shapes with smooth, corrosion-resistant finishes and high strength to weight ratios | Boat hulls, jet skis, and other marine craft |
| Transportation | Parts consolidation, light weight, continuous shapes with smooth corrosion-resistant finishes | Body panels, front ends, bumpers, and interior dashboards for automobiles, mobile homes, buses, and trucks. |

Source: Society of the Plastics Industry, Inc. *Introduction to Composites*. 2nd ed. Washington, DC. The Composites Institute. 1992.

Land transportation products consumed the most reinforced plastics in 1997, followed by construction, as Figure 2-7 illustrates. The land transportation segment alone used 1,095 million pounds, which accounts for 32 percent of the 3.4 billion pounds of RPCs consumed in 1997. Construction applications, the second largest end-use category, consumed 700 million pounds of composites during 1997. Other significant market segments are marine and electrical products. Producers serving the marine segment will not be subject to the proposed controls; they will be separately addressed by the Agency.

Reinforced Plastics Shipments = 3,422 million lbs.

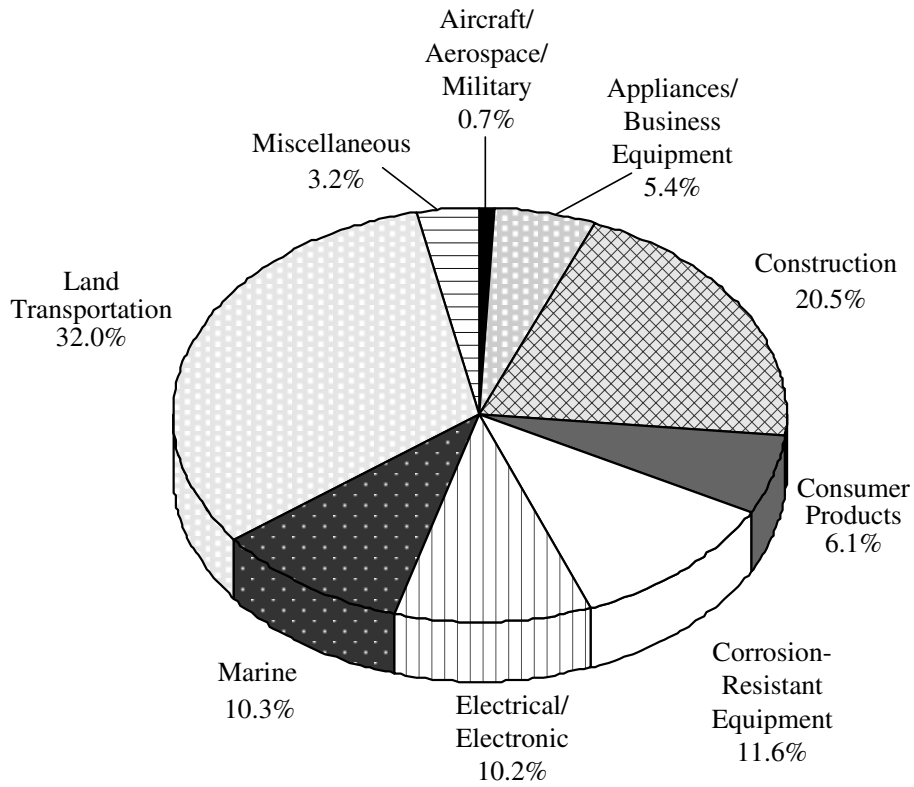

Figure 2-7. Consumption of Reinforced Plastic Composites by Market Segment: 1997

^aIncludes reinforced thermoset and thermoplastic resins, reinforcements, and fillers.

Source: Society of the Plastics Industry, Inc. 1998. *Facts and Figures of the U.S. Plastics Industry*. Washington, DC: SPI.

Table 2-11 indicates that consumption has risen from 1989 levels in all end-use categories except for aviation/aerospace/military, which has declined because of the recent reductions in U.S. government spending on defense. Total shipments have increased every year since 1991. The growth rate for consumption by land transportation was highest for the period 1984-1997, followed by electrical applications. Causes for aggregate growth vary across individual market segments. Growth may be driven by advances in RPC production processes or increased demand for specific final products. Demand in some end-use categories is strongly influenced by fluctuations in consumer confidence or by changes in government spending priorities.

The growth for particular RPC processes and resins may differ from the observed aggregate rates of growth for the markets they serve, which is significant because the RPC source category to be regulated includes only thermosetting resins—mainly unsaturated polyesters. Table 2-12 presents information on consumption of reinforced unsaturated polyesters based on consumption data by end use for 1984 through 1993 from *Predicasts Basebook* and *Modern Plastics*. In contrast to the aggregate growth rates across end-use markets, Table 2-12 shows that growth for reinforced unsaturated polyesters was positive in electrical/electronic (0.7 percent), aircraft/aerospace/military (0.6 percent), appliances/business equipment (0.4 percent annually), and corrosion resistant equipment (0.2 percent). It appears that reinforced unsaturated polyesters are losing market share in many end uses as technological advances allow thermoplastic resins to be used in a wider range of processes and applications.

Some RPC processes may serve multiple end-use markets and, thus, have a different growth rate than those listed in Tables 2-11 and 2-12. In particular, industry sources cited in *Modern Plastics* state that pultruded parts using reinforced polyesters are replacing aluminum, wood, and polyvinyl chloride in various markets and are expected to have a 15 to 25 percent growth rate over the next 5 years (*Modern Plastics*, 1993). Pultrusion is a fully automated fabrication process with low tooling and labor costs that produces continuous, cross-sectional composite profiles, all of which are expected to allow it to continue its strong growth and penetration of traditional material profile markets in the 1990s. Growth is expected to be particularly significant in the electrical and corrosion-resistant markets, with opportunities increasing in the construction and aerospace markets (*Modern Plastics*, 1994).

2.5 Manufacturing Facilities

Table 2-11. Consumption of Reinforced Plastic Composites by End Use: 1984-1997 (10⁶ lbs)^a

| End Use | 1984 | 1985 | 1986 | 1987 | 1988 | 1989 | 1990 | 1991 | 1992 | 1993 | 1994 | 1995 | 1996 | 1997 | Average Annual Growth Rate (1984-1997) |
|-------------------------------|-------|-------|-------|-------|-------|-------|-------|-------|-------|-------|-------|-------|-------|-------|--|
| Aircraft/aerospace/military | 29 | 32 | 37 | 36 | 39 | 41 | 39 | 39 | 32 | 25 | 24 | 24 | 24 | 24 | -3.4% |
| Appliances/business equipment | 123 | 133 | 137 | 141 | 150 | 151 | 153 | 135 | 143 | 148 | 161 | 167 | 170 | 185 | 2.3% |
| Construction | 430 | 445 | 456 | 506 | 495 | 470 | 468 | 420 | 483 | 530 | 597 | 627 | 643 | 700 | 3.2% |
| Consumer products | 143 | 142 | 149 | 167 | 169 | 158 | 165 | 149 | 162 | 166 | 175 | 184 | 192 | 210 | 2.5% |
| Corrosion-resistant equipment | 310 | 295 | 291 | 329 | 349 | 335 | 350 | 355 | 332 | 352 | 376 | 395 | 405 | 396 | 2.3% |
| Electrical/electronic | 189 | 191 | 201 | 214 | 230 | 229 | 241 | 231 | 260 | 275 | 299 | 315 | 328 | 348 | 4.7% |
| Marine | 309 | 335 | 340 | 413 | 452 | 405 | 375 | 275 | 304 | 319 | 364 | 375 | 383 | 353 | 0.1% |
| Land transportation | 540 | 563 | 585 | 656 | 695 | 677 | 705 | 682 | 750 | 822 | 946 | 984 | 1,009 | 1,095 | 5.3% |
| Miscellaneous | 80 | 82 | 83 | 75 | 80 | 76 | 79 | 74 | 83 | 89 | 102 | 107 | 111 | 111 | 2.8% |
| Total ^b | 2,153 | 2,218 | 2,279 | 2,536 | 2,658 | 2,542 | 2,575 | 2,360 | 2,549 | 2,726 | 3,043 | 3,176 | 3,263 | 3,422 | 3.2% |

^a Includes thermosetting and thermoplastic resins, reinforcements, and fillers.

^b Parts may not sum to totals due to independent rounding.

Sources: Lindsay, Karen F. 1996. "State of the Industry: 1995-96." *Composites Design and Application*. February.

Rauch Associates. 1991. *The Rauch Guide to the U.S. Plastics Industry*. Bridgewater, NJ: Rauch Associates, Inc.

Society of the Plastics Industry, Inc. 1994. *Facts and Figures of the U.S. Plastics Industry*. Washington, DC: SPI.

Society of the Plastics Industry, Inc. (SPI). 1998. *Facts and Figures of the U.S. Plastics Industry*. Washington, DC: SPI.

Table 2-12. Consumption of Reinforced Unsaturated Polyester by End Use: 1984-1993 (10⁶ lbs)^a

| End Use | Predicast Code | 1984 | 1985 | 1986 | 1987 | 1988 | 1989 | 1990 | 1991 | 1992 | 1993 | Average Annual Growth Rate ('84-'93) ^b |
|-------------------------------|----------------|-------|-------|-------|-------|-------|-------|-------|-------|-------|-------|---|
| Aircraft/aerospace/military | 30752-20 | 26 | 28 | 32 | 33 | 34 | 35 | 34 | 36 | 31 | 25 | 0.6% |
| Appliances/business equipment | 30754-00 | 86 | 85 | 87 | 90 | 93 | 93 | 93 | 84 | 88 | 91 | 0.4% |
| Construction | 30760-00 | 420 | 400 | 402 | 393 | 414 | 426 | 384 | 337 | 387 | 418 | -0.7% |
| Plumbing fixtures | 30765-00 | 109 | 101 | 102 | 100 | 112 | 115 | 106 | 88 | 94 | 96 | -1.3% |
| Panels and siding | 30761-00 | 125 | 122 | 123 | 115 | 117 | 125 | 109 | 99 | 108 | 116 | -1.6% |
| Glazing and skylights | 30761-40 | 45 | 41 | 40 | 39 | 42 | 50 | 36 | 24 | 27 | 29 | -5.8% |
| Pipe, fittings, conduit | 30766-00 | 141 | 136 | 137 | 139 | 143 | 158 | 139 | 126 | 122 | 122 | -1.4% |
| Consumer products | 30770-00 | 130 | 132 | 130 | 130 | 135 | 138 | 127 | 120 | 122 | 124 | -0.9% |
| Corrosion-resistant equipment | NA | 310 | 320 | 322 | 326 | 338 | 350 | 336 | 329 | 299 | NA | 0.2% |
| Electrical/electronic | 30755-00 | NA | 48 | 52 | 55 | 53 | 53 | 53 | 50 | 53 | 55 | 0.7% |
| Marine | 30752-40 | 308 | 320 | 324 | 350 | 375 | 353 | 300 | 221 | 243 | 255 | -3.7% |
| Land transportation | 30752-00 | 200 | 220 | 200 | 195 | 207 | 221 | 215 | 185 | 190 | 207 | -0.5% |
| Miscellaneous | NA | NA | 52 | 50 | 50 | 51 | 52 | 48 | 45 | 52 | NA | -0.7% |
| Total ^c | | 1,592 | 1,605 | 1,599 | 1,622 | 1,700 | 1,721 | 1,590 | 1,407 | 1,552 | 1,613 | -0.5% |

^a Includes weight of resin, reinforcements, and fillers.

^b Or widest range of available years.

^c Parts may not sum to totals due to independent rounding.

Sources: *Modern Plastics*. "Resin Supply: Plotting a Course for Global Supply." January 1994.
Predicasts Basebook. November 1992. Foster City, CA: Information Access Corporation.

The information provided in this section is based on EPA's 1993 survey of the reinforced plastics industry (EPA, 1993). Although roughly 700 facilities participated in the survey, only 433 facilities were determined to be potential major sources of HAP emissions from the production of reinforced plastics. Thus, this section focuses on those 433 facilities likely to be subject to the proposed air regulations.

2.5.1 Location

Based on the 1993 updated industry screening survey, Figure 2-8 identifies the location of the 433 major source facilities producing reinforced plastics in 1993. Ohio, Indiana, California, Texas, and Pennsylvania are the top five states in order of number of major source facilities.

2.5.2 Employment

The 1993 survey data indicate that employment at these major source facilities ranged from 2 to 1,250 per facility in 1997 with an average of 84 employees for those facilities reporting their employment level. Table 2-13 provides the distribution of major source facilities reporting employment data. Over 80 percent of the 389 facilities reporting employment data had 100 employees or fewer. The vast majority of the remaining facilities reported employment levels between 101 and 500. Less than 3 percent of facilities reporting employment reported have more than 500 employees.

2.6 Facility Ownership

Facilities comprise a site of land with plant and equipment that combine inputs (raw materials, fuel, energy, and labor) to produce outputs (reinforced plastics). Companies that own these facilities are legal business entities that have the capacity to conduct business transactions and make business decisions that affect the facility. The terms facility, establishment, plant, and mill are used synonymously in this analysis and refer to the physical location where products are manufactured. Likewise, the terms company and firm are used synonymously and refer to the legal business entities that own the facilities. As seen in Figure 2-9, the chain of ownership may be as simple as one facility owned by one company or as complex as multiple facilities owned by subsidiary companies.

Potentially affected firms include entities that own facilities manufacturing reinforced plastics. In 1993, 356 companies owned the 433 major source facilities, according to the EPA industry survey (EPA, 1993). Annual sales data were available for 314 of these companies (88 percent). Based on the available small company sales and employment observations, the Agency also estimated sales for

39 of the 42 remaining companies by calculating the ratio of sales to employment for each SIC code and applying the appropriate ratio to the number of employees for each company without sales data. Appendix A lists these companies and their sales and employment figures where available.

2.6.1 Size Distribution

Firm size is likely to be a factor in the distribution of the regulatory action's financial impacts. The 356 firms owning the 433 manufacturing facilities range in size from 3 to 647,000 employees. Table 2-14 shows the size distribution of potentially affected firms by total employment. The majority of firms (78 percent of those with employment data) have 500 employees or fewer. Only 5 percent report employment between 500 and 1,000, while 18 percent report employment over 1,000. Thus, it appears that this industry is composed of a large number of very small and very large firms, which likely results from a large number of smaller specialty product manufacturers and larger integrated manufacturers of durable products.

The majority of firms (82 percent of those with sales data) generated less than \$100 million in annual sales, as Table 2-15 shows. Nine percent report annual sales between \$100 million and \$1 billion, and 9 percent report sales over \$1 billion annually. The distribution of sales appears to be less skewed than the distribution of employment across firms.

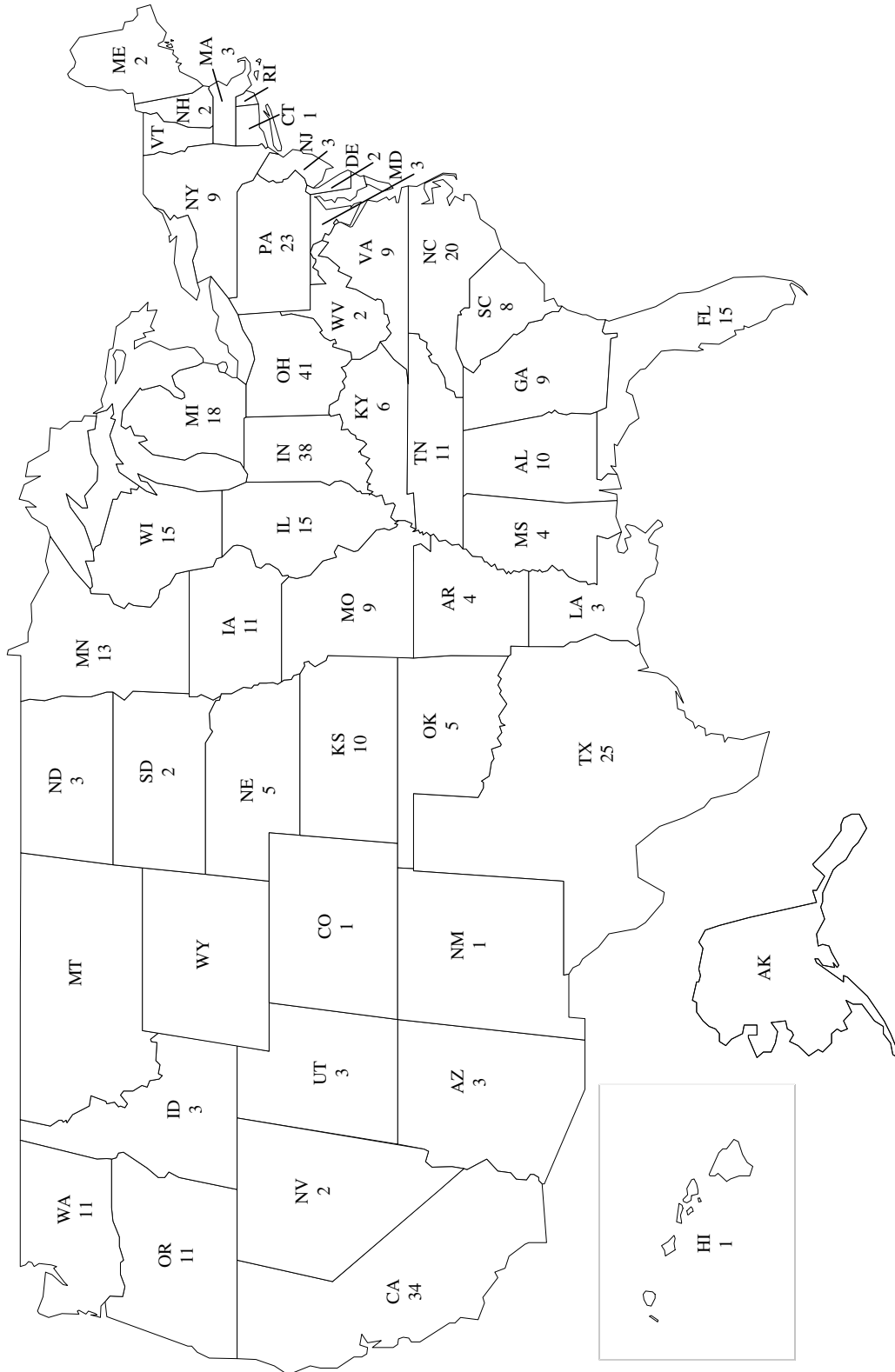

Figure 2-8. Geographic Distribution of Major Source Facilities

Table 2-13. Distribution of Major Source Facilities by Employment

| Employment Range | Number of Facilities | Share of Reporting Facilities (%) |
|-------------------------|-----------------------------|--|
| 0–100 | 313 | 80.5 |
| 101–250 | 46 | 11.8 |
| 251–500 | 20 | 5.1 |
| 501–750 | 4 | 1.0 |
| 751–1,000 | 5 | 1.3 |
| > 1,000 | 1 | 0.3 |
| Total reporting | 389 | 100.0 |
| Not Available | 44 | |

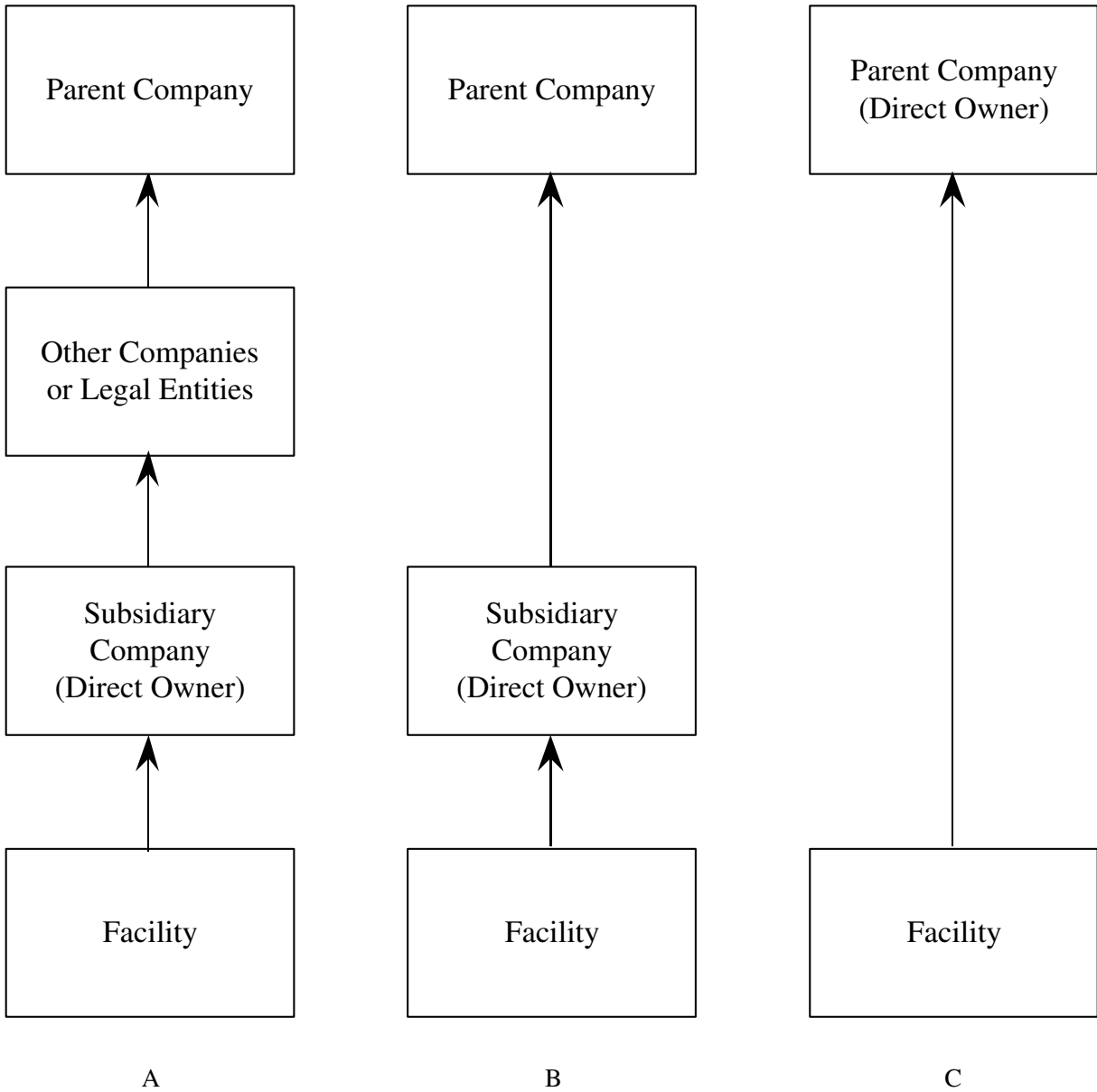

Figure 2-9. Alternative Chains of Ownership

2.6.2 Issues of Vertical and Horizontal Integration

Vertical integration is a potentially important dimension in analyzing firm-level impacts because the regulation could affect a vertically integrated firm on more than one level. For example, the regulation may affect companies for whom reinforced plastic production is only one of several

Table 2-14. Distribution of Potentially Affected Firms by Employment

| Employment Range | Number of Firms | Share of Total (%) |
|-------------------------|------------------------|---------------------------|
| 0–100 | 194 | 55.6 |
| 101–250 | 55 | 15.8 |
| 251–500 | 22 | 6.3 |
| 501–750 | 10 | 2.9 |
| 751–1,000 | 7 | 2.0 |
| >1,000 | 61 | 17.5 |
| Total | 349 | 100.0 |
| Not Available | 7 | |

processes in which the firm is involved. A company that produces reinforced plastics for example may also be involved in manufacturing automobiles, aircraft, sporting goods, and appliances. This firm would be considered vertically integrated because it is involved in more than one level of production including reinforced plastics. A regulation that increases the cost of manufacturing reinforced plastics will also affect the cost of producing the final products that use reinforced plastics in the production process.

Horizontal integration is also a potentially important dimension in firm-level impact analysis. This is because a diversified firm may own facilities in unaffected industries, giving them resources to spend on complying with this regulation—if they so choose. The potentially affected firms in Appendix A demonstrate some diversification as evidenced by the number of subsidiaries and divisions listed. Most are part of larger firms or holding companies that are involved in several different industries.

2.7 Small Businesses

The Regulatory Flexibility Act (RFA) of 1980 as amended by the Small Business Regulatory Enforcement Fairness Act (SBREFA) of 1996 requires that the Agency give special consideration to

Table 2-15. Distribution of Potentially Affected Firms By Sales

| Company Sales | Number of Firms | Share of Total (%) |
|----------------------|------------------------|---------------------------|
| Less than \$5M | 127 | 36.0 |
| \$5M to \$10M | 65 | 18.4 |
| \$10M to \$25M | 52 | 14.7 |
| \$25M to \$50M | 27 | 7.6 |
| \$50M to \$100M | 20 | 5.7 |
| \$100M to \$250M | 12 | 3.4 |
| \$250M to \$500M | 13 | 3.7 |
| \$500M to \$1B | 6 | 1.7 |
| \$1B or greater | 31 | 8.8 |
| Total | 353 | 100.0 |
| Not Available | 3 | |

small entities affected by Federal regulation. This section focuses on identifying the small businesses affected by the proposed NESHAP.

2.7.1 Identifying Small Businesses

The following secondary sources were used to obtain data for the 433 affected manufacturers identified in the industry screening survey (EPA, 1993):

- Business and Company ProFile (Information Access Corporation, 1998)
- Dun and Bradstreet Market Identifiers (Dun & Bradstreet, 1998)
- Ward's Business Directory of U.S. and Private and Public Companies (Gale Research, 1998)
- Worldscope (Disclosure Inc., 1998)
- Standard & Poor's Corporations (Dialog Information Service, 1997)

- Manufacturing USA (Gale Research, 1996)
- Company 10-K Reports

We identified the ultimate parent company and obtained sales and employment data for companies for which data are available. Based on available secondary data, the Agency has determined that 356 parent companies are affected by the regulation. Employment data could be obtained from the above sources for 349 of these parent companies (98 percent).

The Small Business Administration (SBA) defines small businesses based on industry size standards (SBA, 1996). Table 2-16 presents the size standards for the SIC codes covered by the industry survey. As shown, the small business definition for the RPC industry ranges from 500 to 1,000 employees. We developed a company's size standard based on the reported SIC code for its facilities. In determining the companies' SIC, we made the following assumptions:

- In cases where companies own facilities with multiple SICs, the most conservative SBA definition was used. For example, if a company owned facilities within SICs 3714 (size standard = 750 employees) and 3089 (size standard = 500 employees), we assumed the size standard to be 750 employees.
- Thirty-eight facilities report an SIC code of 3079. To our knowledge, this SIC code is not currently used. Therefore, we assigned SIC 3089 to these facilities.
- Twenty-four facilities report no SIC code. We assigned these facilities the most conservative size standard of 1,000 employees.

Based on the SBA's definitions, 278 companies out of 356 (78 percent) were identified as small, as Figure 2-10 shows. These companies own 302 facilities (70 percent of all RPC facilities). Appendix A lists the companies identified as small for this analysis.

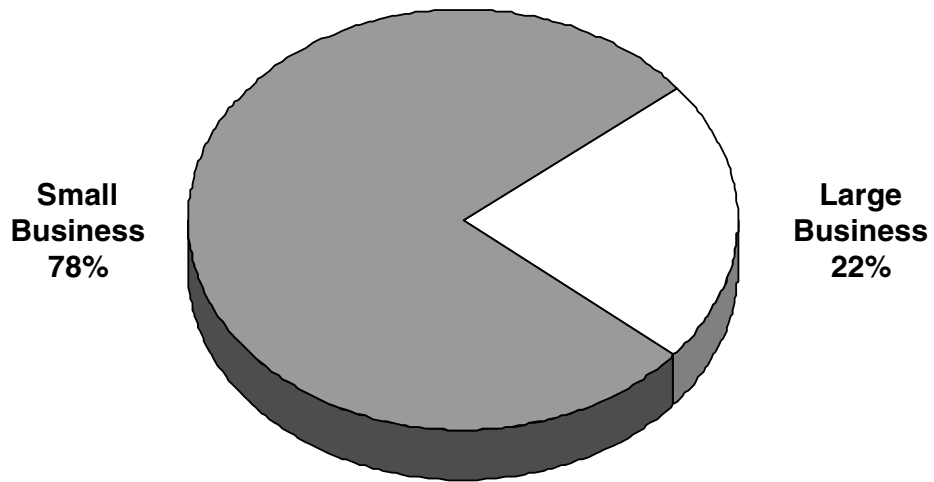

Figure 2-10. RPC Firms by Size

Table 2-16. Small Business Administration Size Standards for RPC—Companies by SIC

| SIC | Small Business Standard | SIC | Small Business Standard |
|------------|--------------------------------|------------|--------------------------------|
| 2434 | 500 | 3564 | 500 |
| 2519 | 500 | 3589 | 500 |
| 2522 | 500 | 3612 | 750 |
| 2541 | 500 | 3613 | 750 |
| 2599 | 500 | 3621 | 1,000 |
| 2821 | 750 | 3647 | 500 |
| 3082 | 500 | 3663 | 750 |
| 3083 | 500 | 3679 | 500 |
| 3084 | 500 | 3711 | 1,000 |
| 3087 | 500 | 3713 | 500 |
| 3088 | 500 | 3714 | 750 |
| 3089 | 500 | 3715 | 500 |
| 3281 | 500 | 3716 | 1,000 |
| 3296 | 750 | 3728 | 1,000 |
| 3299 | 500 | 3743 | 1,000 |
| 3431 | 750 | 3792 | 500 |
| 3499 | 500 | 3799 | 500 |
| 3531 | 750 | 3821 | 500 |
| 3533 | 500 | 3949 | 500 |
| 3546 | 500 | 3993 | 500 |
| 3561 | 500 | 3999 | 500 |

Source: U.S. Small Business Administration. Size Standards by SIC Industry. 1996. Available <<http://www.sba.gov/gopher/Government-Contracting/Size/sizeall.txt>>.

REFERENCES

- American Business Information (ABI). 1999. American Business Disc [computer file].
- Berglund, Lars. 1998. "Thermoplastic Resins." *Handbook of Composites*, S.T. Peters, ed. New York: Chapman and Hall.
- Composite Fabricators Association (CFA). 2000. "Industry Composites Demand for 1999–2000." <<http://www.cfa-hq.org>>. As obtained on July 29, 2000.
- Dialog Information Service. 1997. Standard and Poor's Corporations [computer file]. Palo Alto, CA: Dialog Information Service.
- Disclosure Incorporated. 1998. Worldscope [computer file]. Bethesda, MD: Disclosure Inc.
- Dun & Bradstreet. 1998. *Industry Norms & Key Business Ratios, Desk-Top Edition 1996-97*. Murray Hill, NJ: Dun & Bradstreet.
- Dun & Bradstreet. 1998. Dun's Market Identifiers [computer file]. New York, NY: Dialog Corporation.
- Dun & Bradstreet. 1999. *Million Dollar Directory: America's Leading Public and Private Companies*. Bethlehem, PA: Dun & Bradstreet Corporation.
- Gale Research, Inc. 1996. *Manufacturing USA*. Detroit, MI: Gale Research, Inc.
- Gale Research, Inc. 1998. *Ward's Business Directory of U.S. Private and Public Companies*. Detroit, MI: Gale Research, Inc.
- Information Access Corporation. 1998. Business & Company ProFile [computer file]. Foster City, CA: Information Access Corporation.
- LeFlam, Greg, and Melanie Proctor, PES Inc., memorandum to Madeleine Strum, U.S. Environmental Protection Agency. Industry Description Memorandum. October 17, 1995.

- Lindsay, Karen F. 1996. "State of the Industry: 1995-96." *Composites Design and Application* February.
- Modern Plastics*. "Resin Supply: What's in the Pipeline for '93?" January 1993.
- Modern Plastics*. "Resin Supply: Plotting a Course for Global Supply." January 1994.
- Murphy, John. 1994. *The Reinforced Plastics Handbook*. Oxford, UK: Elsevier Advanced Technology.
- Plastics News*. "Resin Pricing." Updated May 13, 1999. <<http://www.plasticsnews.com>>. As obtained on May 17, 1999.
- Predicasts Basebook*. November 1992. Foster City, CA: Information Access Corporation.
- Rauch Associates. 1991. *The Rauch Guide to the U.S. Plastics Industry*. Bridgewater, NJ: Rauch Associates, Inc.
- Schwartz, Mel. 1997. *Composite Materials: Processing, Fabrication, and Applications*. Upper Saddle River, NJ: Prentice Hall.
- Shearer, Brent. April 15, 1996. "Carbon Fibers Adjusting to Changes." *Chemical Marketing Reporter*.
- Society of the Plastics Industry, Inc. (SPI). 1994. *Facts and Figures of the U.S. Plastics Industry*. Washington, DC: SPI.
- Society of the Plastics Industry, Inc. (SPI). 1998. *Facts and Figures of the U.S. Plastics Industry*. Washington, DC: SPI.
- Society of the Plastics Industry (SPI) Composites Institute. 1992. *Introduction to Composites*. Second Edition. Washington, DC: Society of the Plastics Industry, Inc.
- Society of the Plastics Industry (SPI) Composites Institute. 1995. *Introduction to Composites*. Third Edition. Washington, DC: Society of the Plastics Industry, Inc.
- U.S. Bureau of Labor Statistics. 2000. Producer Price Index—Commodities: WPUSOP9200, Intermediate Materials less food and energy. 1990–2000. [online] <<http://www.bls.gov>>. Obtained January 20, 2000.

U.S. Environmental Protection Agency (EPA). 1993. "Survey of Reinforced Plastics Industry."
Washington, DC: U.S. Environmental Protection Agency.

U.S. Environmental Protection Agency, Office of Enforcement and Compliance Assurance. 1995.
*EPA Office of Compliance Sector Notebook Project: Profile of the Rubber and Plastics
Industry*. Washington, DC: U.S. Environmental Protection Agency.

U.S. Geological Survey. 1997. Minerals Yearbook: Clays. [online] <[http://minerals.usgs.gov/
minerals/pubs/commodity/myb](http://minerals.usgs.gov/minerals/pubs/commodity/myb)>. Obtained January 21, 2000.

U.S. Geological Survey. 1997. Minerals Yearbook: Mica. [online] <[http://minerals.usgs.gov/
minerals/pubs/commodity/myb](http://minerals.usgs.gov/minerals/pubs/commodity/myb)>. Obtained January 21, 2000.

U.S. Small Business Administration. 1996. Size Standards by SIC Industry.
<<http://www.sba.govgopher/Government-Contracting/Size/sizeall.txt>>.