



# Wastewater Technology Fact Sheet In-Plant Pump Stations

## DESCRIPTION

The terrain of the treatment plant site and the influent sanitary sewer depth govern the need for and location of in-plant pumping facilities. In-plant pump stations are facilities that consist of pumps and service equipment designed to pump flows from lower to higher elevations to allow continuous and cost-effective treatment through unit processes within the plant.

The type of pumps most commonly used at wastewater treatment plants include the centrifugal, progressive cavity, and positive displacement. The three types are listed in Table 1 with the different pump applications. Archimedes screw pumps (progressive cavity) are used to pump raw wastewater and return activated sludge in treatment plants, but only in larger facilities because of the high purchase cost. These pumps are popular because they are relatively easy to operate.

The focus of this section will be on centrifugal pumps for raw wastewater and effluent pumping applications.

Key elements of every pump station include: wet well, pumps, piping with associated valves and strainers, motors, power supply system, equipment control and alarm system, odor control system and ventilation system. Pump station equipment and systems are often installed in an enclosed structure. Pump stations can be constructed on site (custom-designed) or pre-fabricated in a factory. Pump station capacities range from 76 lpm (20 gpm) to more than 378,500 lpm (100,000 gpm). Pre-fabricated pump stations generally have capacity of up to 38,000 lpm (10,000 gpm). Usually, pump

**TABLE 1 PUMP APPLICATION**

Pump Type	Typical Application
<b>Centrifugal</b>	Raw Wastewater      Flush Water
	Primary Sludge      Spray Water
	Secondary Sludge      Seal Water
	Effluent Wastewater
<b>Positive Displacement</b>	Primary Sludge
	Thickened Sludge
	Digested Sludge
	Slurries
	Chemical Feed Applications
<b>Progressive Cavity</b>	All types of Sludge
	All types of Slurries

Source: WEF, 1992 and Sanks, 1992.

stations include at least two constant-speed pumps ranging in size from 38 to 75,660 lpm (10 to 20,000 gpm) each and have a basic wet-well level control system to sequence the pumps during normal operation.

The most common method for pump control uses liquid level controls that indicate when a desirable water level is attained in the wet well. A trapped air column, or bubbler system that senses pressure and level, is commonly used for pump station control. Other control alternatives are electrodes placed at cut-off levels, and float switches. A more sophisticated control operation involves the use of variable speed drives.

Buildings, although not necessary for the operation of the pumps, are required if service and repair work have to be carried out on-site, to protect electrical equipment from weather, and to provide room for personnel (sometimes in response to local regulations). Isolation valves are used to close off the pumping station or parts of it for routine inspection and maintenance and repair of the structure. For large pump stations, the wet wells are divided to allow for future repair or rehabilitation while the pump station continues to operate. Large sloping fillets or wet-well mixers are used to minimize solids deposition in the wet wells. Designs for self-cleaning wet wells are becoming more prominent. Pump stations are typically provided with equipment for pump removal. Floor doors or openings above the pump room and an overhead monorail beam, bridge crane, or portable hoist are commonly used.

### Common Modifications

The two most commonly used types of pump stations are the dry-pit or dry-well and submersible pump stations. In dry-well pump stations the pumps and valves are housed in a pump room (dry pit or dry-well), that can be easily accessed. The wet well is a separate isolated chamber attached or located adjacent to the dry-well (pump room) structure.

The submersible pump stations do not have a separate pump room, however, the pump station header piping, associated valves, and flow meters are located in a separate dry vault on the surface for easy access. Submersible pump stations include sealed pumps that operate submerged in the wet well. These submerged pumps are not intended for frequent inspection, but can be removed periodically to the surface and re-installed using guide rails and a hoist. Key advantages of the dry-well pump stations are that they allow an easy access for routine visual inspection and maintenance, and in general they are easier to repair than submersible pumps. Key advantages of the submersible pump station include lower costs than the dry-well stations and an ability to operate without frequent pump maintenance. In addition, submersible pump stations usually do not require large aboveground structures and are easier to

blend-in with the surrounding environment in residential areas. They require less space and typically are easier and less expensive to construct for wastewater flow capacities of 38,000 lpm (10,000 gpm) or less. Figures 1 and 2 illustrate the two types of pumps.

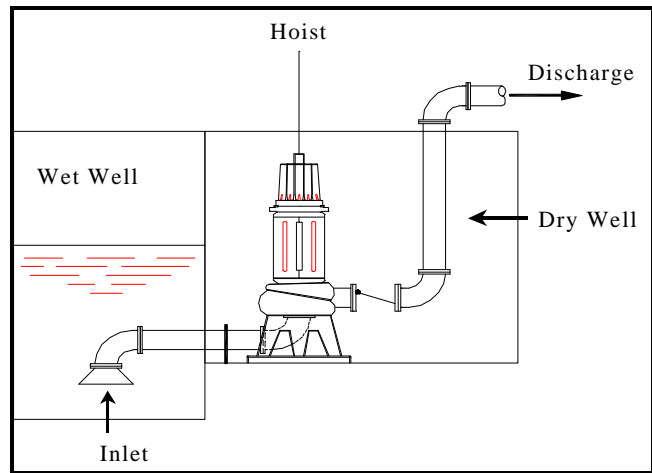

Source: Qasim, 1994.

**FIGURE 1 DRY-WELL PUMP**

Based on the type of construction, two types of pump stations are most common: custom-designed and pre-fabricated (factory-built) pump stations. Custom-designed stations are widely used for large flow applications (22,700 lpm or 6,000 gpm and above) because they can be designed to accommodate practically any set of flows, heads, footprint, and special features. In addition,

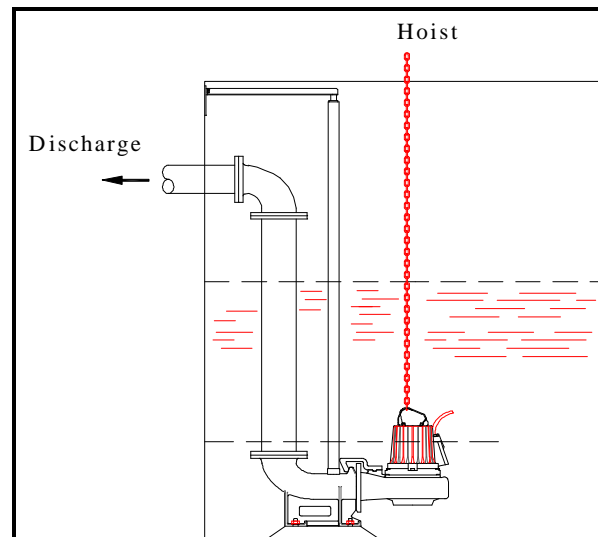

Source: Qasim, 1994.

**FIGURE 2 WET-WELL PUMP**

custom-designed pump stations are typically more spacious and accessible, and have a longer structural life than factory-built pump stations.

Pre-fabricated pump stations are available in various forms and can be either dry-well or submersible. Pre-fabricated pump stations are typically used for smaller flows because they are more compact and generally lower in cost than custom-designed pump stations. Pre-fabricated dry-well pump stations usually include steel or plastic shell that is designed to house one to three vertical-shaft flooded suction pumps. Pumps, valves and other equipment are installed at the factory prior to shipment. Circular station shells are more common and larger pump stations can have an oval shape. Pump station shells are typically bolted to cast-in-place concrete base slabs at the job site. In wet-well configurations, the wet well usually is constructed of pre-cast concrete. Pre-fabricated submersible stations are typically constructed of pre-cast concrete or steel and can accommodate one or two submersible pumps. For pre-cast concrete stations, the pump manufacturer may provide a complete package of equipment, including submersible pumps, discharge elbows, check valves, access hatches, and level controls. For steel stations, the equipment is typically pre-packaged at the factory. Fiberglass tanks are typically used for smaller pump stations.

## **APPLICABILITY**

In-plant pump stations are used to move wastewater from lower to higher elevation, particularly where the elevation of the source is not sufficient for gravity flow and/or the use of gravity conveyance will result in excessive excavation depths and high plant construction costs. In-plant pump stations are used to pump flow from areas too low to drain by gravity into nearby sewer lines.

### **Current Status**

Variable speed pumping is often used to optimize pump performance and minimize power use. Several types of variable-speed pumping equipment are available, including variable voltage and frequency drives, eddy current couplings, and mechanical variable-speed drives. Variable-speed

pumping can reduce the size and cost of the wet well and allows the pumps to operate at maximum efficiency under a variety of flow conditions. Because variable-speed pumping allows pump station discharge to match inflow, only a nominal wet-well storage volume is required and the well water level is maintained at a near constant elevation. Variable-speed pumping may allow a given flow range to be achieved with fewer pumps than would a constant-speed alternative. Variable-speed stations also minimize the number of pump starts and stops, reducing mechanical wear. Although there is a significant energy saving potential for stations with large friction losses, it may not justify the additional capital costs unless the cost of power is relatively high. The variable speed equipment also requires more room within the pump station and may produce more noise and heat than constant speed pumps.

Modern pump stations are equipped with automatic controls for pump starting and operational sequencing. The pump stations typically have standby pumps to increase reliability and provide adequate capacity for unusually high flows. In unattended pumping stations, automatic controllers are frequently used to allow switch over to standby units when a pump fails. Flow recording equipment is often installed to record instantaneous pumping rates and the total flow pumped.

## **ADVANTAGES AND DISADVANTAGES**

### **Limitations**

Compared with gravity conveyance, pump stations require an outside source of power. If the power supply is interrupted, flow conveyance is discontinued. Unless there are overflow structures, discontinuation of pump station operation can result in flooding the area upstream of the pump station and can interrupt the normal operations of the treatment facilities. This limitation is typically handled by providing a stand by power source (e.g., back-up generator).

The useful life of pump station equipment is typically limited to 20 to 30 years, with good maintenance. Pump station structures typically have a useful life of 50 years. The useful life of

pump station equipment and structures can be prolonged by using corrosion-resistant materials and protective coatings.

### **Reliability**

Pump stations are complex facilities that contain a significant number of equipment and auxiliary systems. Therefore, they are less reliable than gravity wastewater conveyance but the pump station reliability can be significantly improved. A way to improve the situation is by providing stand-by equipment (pumps and controls) and emergency power supply systems. In addition, pump station reliability is improved by using screens to remove debris, by using non-clog pumps suitable for the particular wastewater quality, and by applying emergency alarm and automatic control systems. Provisions are often made for emergency overflow or bypass of the pump station to protect engine driven pumps and to provide more reliable and uninterrupted operation.

Pump stations have a relatively low impact on the surrounding air and water and a moderate impact on land during construction. Key potential environmental impacts of constructing a pump station are noise, odor, and emergency sewer overflows to nearby surface waters. Pump motor operation is a source of noise, which if not adequately mitigated, may negatively impact nearby residential developments. In an emergency (pump malfunction, power failure, etc.) a portion of the wastewater conveyed to the pump station may overflow to nearby surface waters causing potential health risk. Emergency sewer overflows are mitigated by installation of highly reliable equipment, providing redundant control systems and installing facilities for overflow storage and/or treatment prior to discharge to surface waters.

Potential odor problems are mitigated by installation of various odor control systems, including reduction of odor release by adding chemicals upstream of the pump station and odorous gases evacuation and treatment at the pump station site. The addition of chemicals should be closely monitored to avoid killing any microorganisms downstream (in the extended aeration process).

### **Advantages**

Use of in-plant pump stations can reduce the depth of plant structures. For example, consider a treatment plant located on uniform ground elevation. Installation of an influent pump station at the headworks of the facility could significantly reduce the depth of downstream structures (such as aeration basins, clarifiers, and contact basins), thereby reducing capital construction costs for the entire facility.

### **Disadvantages**

Key disadvantages of in-plant pump stations compared to gravity conveyance, are that they are costly to operate and maintain, and are a potential source of odors and noise. In addition, pump stations require a significant amount of power and are prone to flooding during pump failure, which may spread over the adjacent structures.

Primarily due to the low cost of gravity conveyance and the higher costs of operating and maintaining in-plant pump stations, the minimizing of in-plant wastewater pumping should be a primary design consideration.

### **DESIGN CRITERIA**

Cost effective pump stations are designed to: (1) match pump capacity, type and configuration with wastewater quantity; (2) provide reliable and interruptible operation; (3) allow for easy operation and maintenance of the installed equipment; (4) accommodate future capacity expansion; (5) avoid septic conditions and excessive release of odors in the collection system and at the pump station; and (6) avoid flooding of the pump station and the surrounding areas.

### **Wet Well**

Wet-well design is dependent on the type of pump station configuration (submersible or dry-well) and the type of pump controls (constant or variable speed). Wet-wells are typically designed large enough to prevent rapid pump cycling, but small enough to prevent a long detention time and associated odor release.

Wet-well maximum detention time in constant speed pumps is typically 20 to 30 minutes. Use of variable frequency drives for pump speed control allows wet-well detention time reduction to 5 to 15 minutes. Wet-well bottom slope should be designed to allow self-cleaning and minimum deposition of debris. Bar screens are often installed in or upstream of the wet well to minimize pump clogging problems; however, screens are not typically required for in-plant stations because coarse material is generally removed at headworks in the plant.

## **Wastewater Pumps**

The number of wastewater pumps and associated capacity should be selected to provide head-capacity characteristics (elevation of a free surface of water) that correspond, as closely as possible, to the wastewater quantity fluctuations. This can be accomplished by the preparation of pump/pipeline system head-capacity curves showing all conditions of head and capacity under which the pumps will be required to operate.

The number of pumps to be installed in the pump station depends largely on the station capacity and range of flow. In small stations, with maximum flows of less than 2580 lpm (680 gpm), two pumps are customarily installed, with each unit having capacity to meet the maximum influent rate. For larger pump stations, the size and the number pumps should be selected so that the flow range can be met without frequent starting and stopping of pumps and without requiring excessive wet-well storage.

The pumps are designed to run alternately in an effort to keep wear and tear even, as well as keeping all of the parts are lubricated. Additional pumps may be needed to provide intermediate capacities that are better matched to typical daily flows. Another option is to provide flow flexibility with variable-speed pumps. Usually, the single pump peak flow approach is most suitable for stations that have relatively rapid flow increase or high headlosses. For such stations, parallel pumping is not as effective, because two pumps operating together yield only slightly higher flows than one pump. If the peak flow is to be achieved

with multiple pumps in parallel, the pump station will need to be equipped with at least three pumps: two duty pumps that together provide peak flow and one standby pump for emergency backup. Parallel peak pumping is typically used for large pump stations with relatively flat system head curves. Such operation allow multiple pumps to deliver substantially more flow than a single pump. In addition, use of multiple pumps in parallel provides more flexibility.

Several types of centrifugal pumps are frequently used at in-plant pump stations. In straight-flow centrifugal pumps the wastewater does not change direction of flow as it passes through the pumps and into the discharge pipe. These pumps are suitable for low-flow/high head conditions. In angle-flow pumps, the wastewater enters the impeller axially and passes through the volute casing at 90 degrees to its original direction (Figure 3). This type of pump is appropriate for pumping against low or moderate heads. Most viable for pumping large quantities of wastewater at low head are the mixed flow pumps. In these pumps, the outside diameter of the impeller is less than that of an ordinary centrifugal pump, hence the flow speed is greater.

## **Ventilation**

Ventilation and heating are required if the lift station includes an area of the facility that is routinely entered by personnel. Ventilation is particularly important to prevent the collection of toxic and/or explosive gases in the pump station. According to the National Fire Protection Association (NFPA) 820, all continuous ventilation systems should be fitted with flow detection devices connected to alarm signaling systems to indication ventilation system failure. Dry-well ventilation codes typically require 6 continuous air changes per hour or 30 intermittent air changes per hour. Wet wells typically require 12 continuous air changes per hour or 60 intermittent air changes per hour. Motor control center (MCC) rooms should have a ventilation system adequate to provide 6 air changes per hour and should be air conditioned to 13 to 32 degrees C (55 to 90 degrees F). If the control room is combined with an MCC room, the temperature should not exceed 30 degrees C or 85

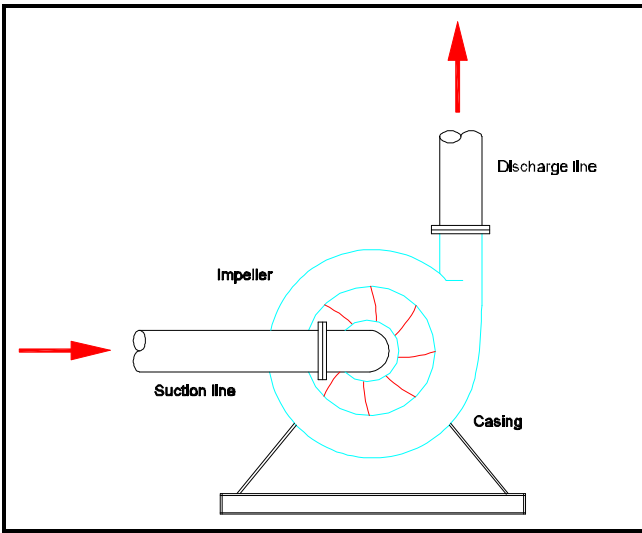

Source: Lindeburg, revised edition 1995.

**FIGURE 3 CENTRIFUGAL ANGLE-FLOW PUMP**

degrees F. All other spaces should be designed for 12 air changes per hour. Minimum temperature should be 13 degrees C (55 degrees F) whenever chemicals are stored or used.

**Odor Control**

Odor control is frequently required for pump stations. A relatively simple and widely used odor control alternative includes minimizing wet-well turbulence. More effective options include collection of odors generated at the pump station and their treatment in scrubbers or biofilters, or the addition of odor control chemicals to the sewer upstream of the pump station. Chemicals typically used for odor control include chlorine, hydrogen peroxide, metal salts (ferrous chloride and ferric sulfate); oxygen, air and potassium permanganate.

**Power Supply**

The reliability of power for the pump motor drives is a basic design consideration. Commonly used methods for emergency power supply include electric power feed from two independent power distribution lines; an on-site standby generator; an adequate portable generator with quick connection; a stand-by engine driven pump; ready access to a suitable portable pumping unit and appropriate connections; and availability of an adequate holding

facility for wastewater storage upstream of the pump station.

**PERFORMANCE**

The overall performance of the pump stations depends on the performance of their pumps. All pumps have four common performance characteristics: capacity, head, power and overall efficiency. Capacity (flow rate) is the quantity of liquid pumped per unit of time, typically measured as gallons per minute (gpm) or million gallons per day (mgd). Head is the energy supplied to the wastewater per unit weight, typically expressed as feet of water. Power is the energy consumed by a pump per unit time, typically measured as kilowatt-hours. Overall efficiency is the ratio of useful hydraulic work performed to the actual work input. Efficiency reflects the pump relative power losses and is usually measured as a percentage of the applied power.

Pump performance curves (Figure 4) are used to define and compare the operating characteristics of a given pump and to identify the best combination of performance characteristics under which the pump station pumping system will operate under typical conditions. Well designed pump systems operate at 75 to 85 percent efficiency most of the time. The overall pump efficiency is highly dependent on the type of the installed pumps, their control system and the fluctuation of the influent wastewater flow. Performance optimization

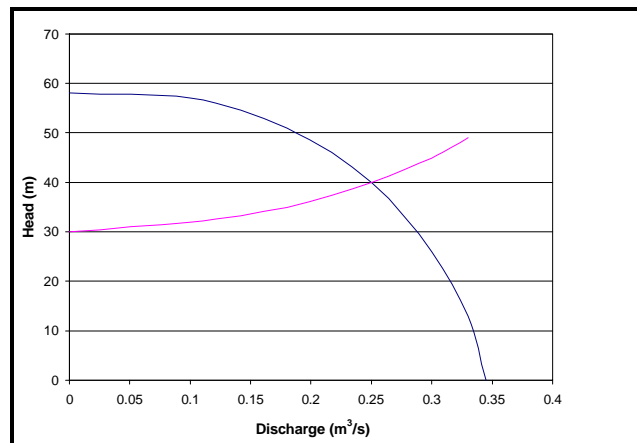

Source: Adapted from Roberson and Crowe, 1993.

**FIGURE 4 PUMP PERFORMANCE CURVE**

strategies focus on matching pump operational characteristics with system flow and head requirements. They may include the following options: adjusting system flow paths; installing variable speed drives; using parallel pumps; installing pumps of different sizes; trimming a pump impeller; putting a gear reducer and a two-speed motor on one or more pumps in the pump station. While savings will vary with the system, electrical energy savings in the range of 20 to 50 percent are possible by optimizing system performance.

## **OPERATION AND MAINTENANCE**

Pump station operation is usually automated and does not require continuous on-site operator presence. However, frequent inspections are recommended to assure normal functioning of pump station equipment and to identify potential problems early. Weekly pump station inspection typically includes observation of pumps, motors and drives for unusual noise, vibration, heating or leakage; check of pump suction and discharge lines for valving arrangement and leakage; check of control panel switches for proper position; monitoring of discharge pump rates and pump speed; and monitoring of pump suction and discharge pressure. If a pump station is equipped with bar screens to remove coarse materials from the wastewater, these materials are collected automatically or manually in containers and disposed to a sanitary landfill site once a week or as needed. If the pump station has a scrubber system for odor control, chemicals for this system are supplied and replenished typically once every one to three months. If chemicals are added for odor control ahead of the pump station, the chemical feed stations should be inspected weekly and chemical supplies replenished as needed.

The most labor-intensive task for pump stations is routine preventive maintenance. A well-planned maintenance program for pump station pumps prevents unnecessary equipment wear and downtime. Regardless of the excellence of servicing programs, equipment use causes wear and, ultimately, failure or breakage of parts. Pump station operators must have an inventory of critical spare parts available. The number of spare parts in

the inventory depends on the critical needs of the unit, the rate at which the part would normally fail, and the availability of the part. The operator of the pump station needs to tabulate each pumping element in the system and its recommended spare parts. This information is typically available from the manufacturer's operation and maintenance manuals provided with the pump station.

## **COSTS**

In-plant pump station costs depend on many factors including: (1) flow and quantity of the liquid being pumped, (namely, wastewater, sludge or chemicals); (2) depth of the required structures; (3) alternatives for standby power sources; (4) operation and maintenance needs and support; (5) soil properties and underground conditions; (6) the severity of impact of accidental sewage spill upon the local area; and (7) the need for an odor control system. These site and system specific factors must be examined and incorporated in the preparation of pump station cost estimate.

### **Construction Costs**

The most important factors influencing costs are the design pump station capacity and the installed pump power. Another important cost factor is the pump station complexity. Factors which would classify a pump station as complex include two or more of the following items: (1) subsurface condition; (2) congested site and/or restricted access; (3) rock excavation; (4) extensive dewatering requirements such as cofferdams; (5) site conflicts, including modification or removal of existing facilities; (6) special foundations including piling; (7) dual power supply and on-site switch stations and emergency power generator; (8) high pumping heads.

Typically in-plant pump stations are less expensive than their collection system (lift station) counterparts. Pump station construction has a significant economy-of-scale. Typically, if the capacity of a pump station is increased 100 percent, the construction cost would only increase about 50 to 55 percent. An important practical consideration is that two identical pump stations would cost approximately 25 to 30 percent more than a single

station of the same combined capacity. Usually, complex pump stations cost two to three times more than more simple pump stations with no construction complications.

Construction costs for in-plant pump stations are usually not segregated, but rather included in the overall capital construction costs for a treatment facility. Therefore, there is a wide range of costs starting as low as \$30,000 and reaching as high as \$1,000,000 (Pasco, 2000). The low end cost is for small plants while the higher end includes sophisticated equipment and/or a large plant.

### Operation and Maintenance Costs

Pump station operation and maintenance (O&M) costs include costs for power, labor and maintenance. If chemicals are used at the pump station for odor control, O&M costs will include the cost for chemicals. Usually, the costs for solids disposal are minimal, but are considered a part of the O&M costs if the pump station is equipped with bar screens to remove coarse materials from the wastewater. Typically, power costs are 85 to 95 percent of the total O&M costs and are directly proportional to the unit cost of power and the actual power used by the pump station pumps. Labor costs are usually 1 to 2 percent of total O&M costs. Annual maintenance costs vary, depending on the complexity of the equipment and instrumentation.

### REFERENCES

#### Other Related Fact Sheets

Sewers, Lift Stations  
EPA 832-F-00-073  
September, 2000

Other EPA Fact Sheets can be found at the following web address:  
<http://www.epa.gov/owmitnet/mtbfact.htm>

1. Cavalieri R.R. and G. L. Devin *Pitfalls in Wet Weather Pumped Facilities Design*. In Proceedings of the Water Environment Federation, 71<sup>st</sup> Annual Conference, Orlando, Florida, Vol. 2, 719-729, October 1998.
2. Don Casada. *Pump Optimization for Changing Needs*. Operations Forum. Vol. 9, No. 5, 14-18, May 1998.
3. Environmental Protection Agency. *Design Manual. Odor and Corrosion Control in Sanitary Sewerage Systems and Treatment Plants*. EPA/625/1-85/018, October 1985.
4. Gravette B. R. *Benefits of Dry-pit Submersible Pump Stations*. In Proceedings of the Water Environment Federation, 68<sup>th</sup> Annual Conference, Miami Beach, Florida, Vol. 3, 187-196, October 1995.
5. Graham B, J., Pinto T.G. and T. Southard. *Backyard Pumping Stations – The Low-pressure Grinder Systems That Call Old Septic Tanks Home*. Operations Forum, Vol. 10, No. 5, 25-29, May 1993.
6. Jackson J. K. *Variable Speed Pumping Brings Efficiency to Pump Systems*. Operations Forum, Vol. 13, No. 5, 21-24, May 1996.
7. Lindeburg, Michael R. *Civil Engineering Reference Manual*, 6<sup>th</sup> ed., Professional Publications, Inc., revised edition 1995.
8. Makovics J. S. and M. Larkin. *Rehabilitating Existing Pumping Systems: Trips, Traps and Solutions*. Operations Forum, Vol. 9, No. 5, 10-17, May 1992.
9. Metcalf & Eddy Inc., *Wastewater Engineering: Collection and Pumping of Wastewater*, McGraw Hill Book Company, 1981.
10. National Fire Protection Association. *National Fire Codes*. Volume 7, Section 820. Quincy, Massachusetts, 1995.
11. Paschke N.W. *Pump Station Basics – Design Considerations for a Reliable Pump Station*. Operations Forum, Vol. 14, No. 5, 15-20, May 1997.



12. Public Works Journal. *The 1997 Public Works Manual*. April 15, 1997.
13. Qasim, Syed R. *Wastewater Treatment Plants - Planning Design, and Operation*. Technomic Publishing company, Inc., 1994.
14. Rotondo/Carlgen, 2000. Ken Pasco, personal communication with Parsons Engineering Science, Inc.
15. Russell Edward. *Screw-Pump Preservation*. Operations Forum, Vol. 9, No. 5, 18-19, May 1992.
16. Sanks R. L., Tchobanoglous G., Newton D., Bosserman, B.E., Jones, G. M. *Pumping Station Design*, Butterworths, Boston, 1989.
17. Schneller T. M. *Pumping it Up? Practical Means For Evaluating Lift Station Fitness*. In Proceedings of the Water Environment Federation, 68<sup>th</sup> Annual Conference, Miami Beach, Florida, Vol. 3, 155-166 October 1995.
18. Smith E. C. *Don't Lose the Pump Efficiency Game*. Operations Forum, Vol. 11, No. 7, 18-21, July 1994.
19. Seigal S.E. *Upgraded to the World's Largest. Dry-Pit/Submerged Pumps Make the Grade*. Operations Forum, Vol. 11, No. 5, 24-28, May 1994.
20. Water Environment Federation. *Design of Municipal Wastewater Treatment Plants, Manual of Practice No. 8*, 1992.

## ADDITIONAL INFORMATION

Miami-Dade Water and Sewer Department  
Luis Aguiar, Assistant-Director  
4200 Salzedo Street  
Coral Gables, FL 33146

East Bay Municipal Utility District  
Eileen M. White  
P.O. Box 24055  
Oakland, CA 94523

Wastewater Treatment Plant  
Richard R. Roll  
P.O. Box 69  
Niagara Falls, NY 14302

City of Houston DPW and Engineering  
Gary N. Oradat  
Utility Maintenance Division  
306 McGowen Street, Houston, TX 7706

City of Fayetteville  
David Jurgens  
113 West Mountain Street  
Fayetteville, AR 72701

Water & Wastewater Utility  
Bruno Conegliano  
City of Austin, P.O. Box 1088  
Austin, TX 78767

The mention of trade names or commercial products does not constitute endorsement or recommendations for use by the United States Environmental Protection Agency (EPA).

For more information contact:

Municipal Technology Branch  
U.S. EPA  
Mail Code 4204  
1200 Pennsylvania Avenue, NW  
Washington, D.C. 20460