

BIOMASS REACTIVITY IN GASIFICATION
BY THE HYNOL PROCESS

Yuanji Dong
Acurex Environmental Corporation
4915 Prospectus Drive
Durham, NC 27709

Robert H. Borgwardt
U.S. Environmental Protection Agency
National Risk Management Research Laboratory
Air Pollution Prevention and Control Division
Research Triangle Park, NC 27711

Keywords: biomass gasification; gasification kinetics; biomass-to-methanol.

INTRODUCTION

Methanol has many advantages to be considered as an alternative fuel. About 75% of methanol production uses natural gas as feedstock. Use of biomass as feedstock to produce methanol is of current interest because it offers substantial benefits for reduction of greenhouse gas emissions. The research and development of biomass-to-methanol processes, one of which is called Hynol, are now in progress.

The Hynol process was proposed to utilize biomass as a feedstock and natural gas as a cofeedstock to increase methanol yield and reduce costs (Steinberg and Dong, 1994). The process consists of three reaction steps: (1) gasification of biomass with the H₂-rich gas recycled from methanol synthesis, (2) steam reforming of the produced gas with an addition of natural gas feedstock, and (3) methanol synthesis from the H₂ and CO produced by the reformer. A schematic flow diagram of the process is shown in Figure 1. Since the reaction of biomass with the H₂ in the recycle gas to form CH₄ is exothermic, the heat so generated is able to offset the energy required for other endothermic reactions in a Hynol gasifier. As a result, no expensive O₂ plant or external heat source is needed for gasification. The use of natural gas as cofeedstock eases the requirement for a consistent composition of biomass feedstock. The integrated cyclical process configuration helps ensure the completion of overall conversion and increases thermal efficiency. CO shifting is not necessary and the requirement for acid gas removal is reduced, which lowers capital and operating costs.

A theoretical evaluation of the Hynol process conducted by the Air Pollution Prevention and Control Division (APPCD) of the National Risk Management Research Laboratory, U.S. Environmental Protection Agency (EPA), showed that the Hynol process represents a promising technology for maximizing fuel production inexpensively and with minimum greenhouse gas emissions (Borgwardt, 1995). Consequently, the APPCD established a laboratory to further assess the process feasibility. In the first phase of the study, a thermobalance reactor (TBR) was installed and used to evaluate biomass reactivity in gasification at the operating pressure, temperature, and feed gas composition specific for the Hynol process. The experimental work also attempted to improve understanding of the variables affecting Hynol gasification and identify needs for process development. This article summarizes the TBR results.

EXPERIMENTAL

A flow diagram of the TBR system is detailed in Figure 2. The reactor is electrically heated and consists of a 35-mm I.D. stainless steel reactor pipe, a 305-mm O.D. pressure vessel, and a topwork which accommodates a weight transducer for measurement of sample weight during reaction. A pulley assembly is used to raise and lower a sample basket between the topwork and the reaction zone.

To initiate an experimental run, a basket with known weight of biomass sample was placed into the topwork through the removable window. A constant helium flow was introduced to the topwork to protect the wood sample from contact with process gas prior to entry in the reaction zone. Mass flow controllers were used to control the flow rates of H₂, CH₄, CO, and CO₂ from individual gas cylinders to obtain the desired feed gas composition. Steam was added to the feed gas from a steam generator fed with distilled water by a metering pump. The gas mixture was further heated by a superheater and then entered the reactor. The reactor exit gas was cooled in a condenser to remove moisture, and then depressurized through a back-pressure regulator before it was vented to atmosphere. When pressure and temperature in the reactor system were stabilized at the desired levels, the sample basket was lowered into the reaction zone and the change in sample

weight was automatically recorded by the transducer as a function of reaction time. A computer was used to control the TBR system and log experimental data. After gasification, the basket was raised back into the topwork and the reactor was depressurized and cooled. The discharged char was then weighed to determine the final sample weight. Because changes in gas composition across the sample are negligible, the reaction can be considered to take place at constant operating conditions.

In this study, the Hynol feed gas refers to a composition -- $H_2 = 65.83\%$; $CH_4 = 11.63\%$; $CO = 8.95\%$; $CO_2 = 2.32\%$ and steam = 11.27% -- which is based on the results of a Hynol process simulation. Poplar wood, which is considered a primary candidate for large scale production as an energy crop for fossil fuel displacement (Wright, 1995), was used as a representative biomass sample. It was grown in North Carolina and cut to desired sizes and dried before its use. Composition is presented in Table 1.

KINETIC MODEL AND DATA TREATMENT

The weight transducer output was recorded as a function of reaction time during a test. The records were converted into the data of variation in sample weight with time. The biomass conversion, X , on an ash-free basis was then calculated by :

$$X = \frac{W_0 - W}{W_0 - W_0 C_A} \quad (1)$$

where W_0 is the initial sample weight, W is the sample weight at any reaction time, C_A is the weight fraction of ash obtained from the ultimate analysis of the original sample, and X is thus also a function of reaction time.

General observation of the reaction behavior revealed that biomass gasification under Hynol conditions involves two types of reactions: a rapid reaction, which may complete in a few seconds, involving devolatilization and pyrolysis reaction of the volatile matter in biomass with H_2 and steam; and a very slow reaction of residual carbon with the process gas which requires hours to finish. To quantitatively describe the rate of gasification, these two reactions are assumed to be first order with respect to the remaining solid reactants. The rate of the rapid reaction can be expressed as:

$$\frac{dX_1}{dt} = k_1 (X_C - X_1) \quad (2)$$

and the rate expression for the slow reaction is:

$$\frac{dX_2}{dt} = k_2 (1 - X_C - X_2) \quad (3)$$

where X_1 and X_2 are the conversions by the rapid and slow reactions at time t , X_C is the maximum attainable conversion by the rapid reaction, and k_1 and k_2 are the reaction rate constants for the rapid reaction and the slow reaction, respectively.

By integrating Equations (2) and (3), the total biomass conversion can be expressed by:

$$X = X_1 + X_2 = 1 - X_C \exp(-k_1 t) - (1 - X_C) \exp(-k_2 t) \quad (4)$$

The model involves three parameters: X_C , k_1 , and k_2 , which are functions of operating conditions such as biomass properties, reaction temperature, pressure, and feed gas composition. They can be determined by fitting Equation (4) to the experimental conversion data obtained from TBR tests.

RESULTS AND DISCUSSIONS

The above model was used to correlate the experimental data obtained from TBR tests. Figure 3 is a typical example of curve fitting results by the model, showing good agreement between the experimental data and the model regression over the entire reaction period.

Four different sizes of poplar particles were used to investigate the effects on gasification: 7/16-in diameter cylinders, 1/4-in diameter cylinders, 1/8-in cubes, and 20 to 30 mesh sawdust. The

rate of the rapid reaction increased significantly as a result of higher heat transfer and intraparticle diffusion rates when particle size was reduced from 7/16- to 1/8-in. Agglomeration during gasification was observed for the particles larger than 1/8-in, which inhibited gas diffusion within the particles. Sawdust heated up more quickly, and no agglomeration was observed. Experimental results showed that, at 30 atm and 800°C, about 87% of the 1/8-in poplar particles and 90% of the sawdust can be gasified by the Hynol feed gas in 60 min.

The analysis of the charred samples obtained from 7/16-in poplar particles showed that some of the volatile matter remains after gasification. However, for 1/8-in poplar particles or sawdust, nearly all of the H and O were converted into product gas in 20 min.

The agglomerates of residual chars formed in the TBR were fragile. If a fluidized bed gasifier is used, agglomeration is not likely to occur as a result of attrition; therefore, higher reaction rate and conversion than observed in TBR testing are expected in such systems.

The rapid-reaction stage of poplar gasification was found to be essentially completed in less than 0.2 to 0.3 min, contributing most of the biomass conversion. A small additional conversion is contributed by the slow reaction. To achieve high biomass conversion, sufficient gasification time must be provided. Tests showed that biomass conversion increased from 85 to 90% when gasification time extended from 20 to 150 min. The comparison between the compositions of chars after 20 and 150 min gasification indicated that there was virtually no further conversion of H and O in the char after 20 min and that the additional conversion resulted from the reaction of carbon with the process gas.

Experimental results of 60-min gasification with sawdust and 1/8-in poplar particles at different reaction temperatures showed great increase in biomass conversion and gasification rates when temperature increased from 750 to 950°C as shown in Figure 4. The rate constants for the rapid and slow reactions, k_1 and k_2 , at different reaction temperatures were determined by fitting the experimental data for gasification of 1/8-in poplar particles. The rate constants thus obtained were plotted against the reciprocal of the absolute temperature, as shown in Figure 5, and expressed as functions of reaction temperature by the Arrhenius equation:

$$k_i = k_{i0} \exp\left(-\frac{E_i}{RT}\right) \quad (5)$$

where subscript i is 1 for the rapid reaction and 2 for the slow reaction. E_i is the activation energy. The results obtained were: $k_{10} = 108.85 \text{ min}^{-1}$, $E_1 = 3.78 \text{ kcal/mol}$, $k_{20} = 22925 \text{ min}^{-1}$, and $E_2 = 34.1 \text{ kcal/mol}$. The maximum attainable conversion by the rapid reaction, X_C , was also correlated as a function of temperature for gasification of 1/8-in poplar particles by:

$$X_C = 0.9611 - 0.000149T \quad (6)$$

where T is the reaction temperature in °C. With Equations (4), (5), and (6) and the values of k_{10} , E_1 , k_{20} , and E_2 , the conversions of 1/8-in poplar particles at different temperatures and gasification times were predicted. Figure 6 compares the prediction with the conversion data obtained from the separate experimental tests at different temperatures and gasification times. The comparison covers a temperature range of 750 to 950°C and a gasification time range from 0.2 to 150 min for 1/8-in poplar particles gasified by the Hynol feed gas at 30 atm. The activation energy obtained for the rapid reaction was low, implying that heat transfer dominates the rates of devolatilization and pyrolysis of biomass in the TBR.

The effect of feed gas composition on poplar gasification was investigated by varying the flow rates of individual gas components under constant system pressure. Helium was used as an inert "make-up" gas for this purpose. At 30 atm and 800°C, the final conversion of poplar wood gasified by pure helium after 60 min was about 6% lower than that obtained under pure H_2 . If the conversion obtained after 60 min of gasification is plotted against H_2 partial pressure (P_{H_2}), a linear relationship, $\text{conversion} = 0.0017 \times P_{H_2}$, was found. When steam partial pressure in the feed gas was varied from 7 atm to zero while the partial pressures of other gas components remained constant, the conversion was proportional to steam partial pressure or $0.003 \times P_{H_2O}$. Negligible effects on the gasification conversion and reaction rate of 1/8-in poplar particles were observed as the CH_4 in the feed gas was reduced from the simulated Hynol composition, 11.63%, to zero. Replacing CO and CO_2 in the feed gas with helium did not affect the gasification rate. The conversion and reaction rates of 1/8-in poplar particles gasified by the Hynol feed gas were nearly the same as those observed by the feed gas containing no CO and CO_2 .

REFERENCES

Borgwardt, R. (1995): The Hynol Process, Presented at Symposium on Greenhouse Gas Emissions and Mitigation Research, Washington, DC. June 27-29.

Steinberg, M. and Dong, Y. (1994): Process and Apparatus for the Production of Methanol from Condensed Carbonaceous Material, U.S. Patent 5,344,848.

Wright, L. (1995): Demonstration and Commercial Production of Biomass for Energy, Proceedings, Second Biomass Conference of the Americas, NREL/CP-200-8098, National Renewable Energy Laboratory, Golden, CO, pp. 1-10.

TABLE 1. COMPOSITION OF POPLAR WOOD USED

Carbon (wt.%)	51.52	Volatile (wt.%)	91.38
Hydrogen (wt.%)	6.20	Fixed carbon (wt.%)	8.15
Oxygen (wt.%)	41.37		
Ash (wt.%)	0.47	Higher heating value	
Sulfur (wt.%)	0.02	(Btu/lb dry wood)	8768.
Nitrogen (wt.%)	0.42		

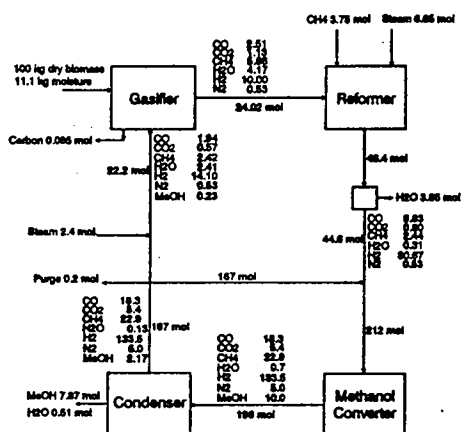

Figure 1. Schematic flow diagram of the Hynol process.

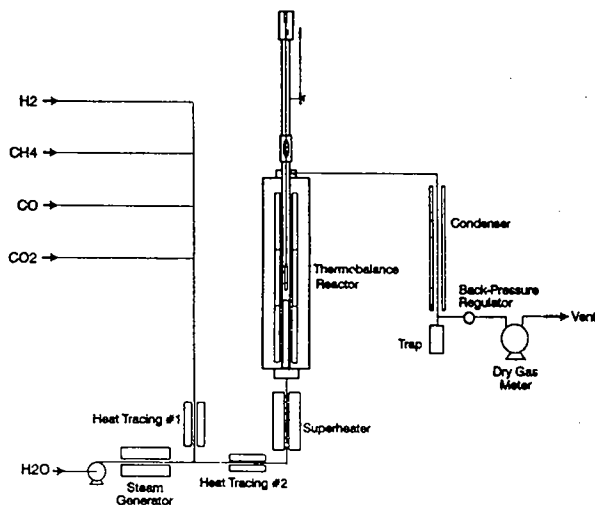

Figure 2. Flow diagram of the TBR system.

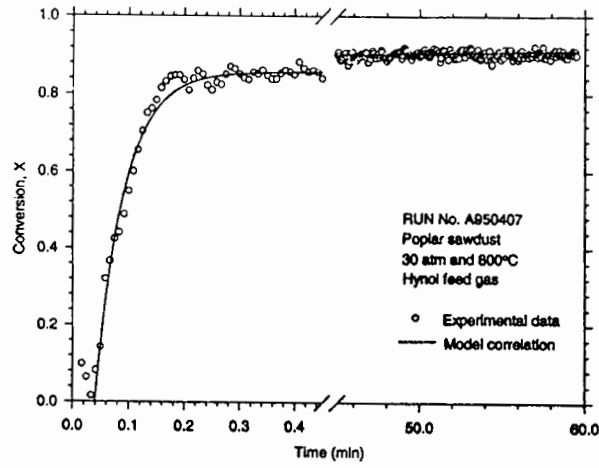

Figure 3. Example of TBR experimental data fitting by the model.

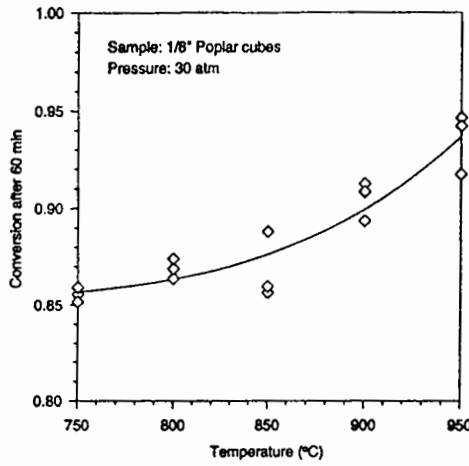

Figure 4. Effect of reaction temperature.

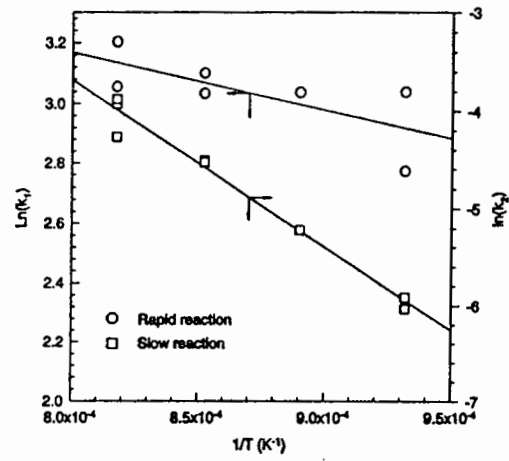

Figure 5. Arrhenius plots of the rate constants.

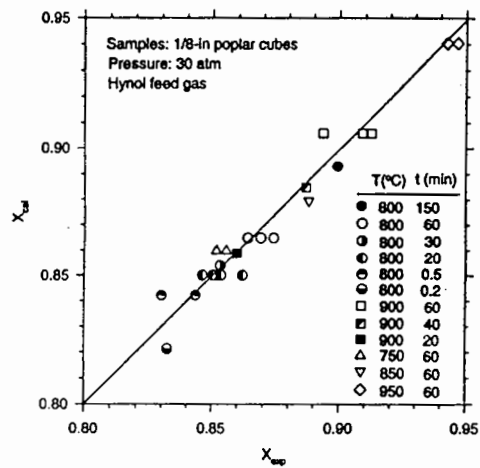

Figure 6. Comparison of the model prediction with experimental conversion data.

TECHNICAL REPORT DATA		
(Please read Instructions on the reverse before completing)		
1. REPORT NO. EPA/600/A-97/010	2.	3. RI
4. TITLE AND SUBTITLE Biomass Reactivity in Gasification by the Hynol Process		5. REPORT DATE
		6. PERFORMING ORGANIZATION CODE
7. AUTHOR(S) Yuanji Dong (Acurex) and Robert H. Borgwardt (EPA)		8. PERFORMING ORGANIZATION REPORT NO.
9. PERFORMING ORGANIZATION NAME AND ADDRESS Acurex Environmental Corporation 4915 Prospectus Drive Durham, North Carolina 27709		10. PROGRAM ELEMENT NO.
		11. CONTRACT/GRANT NO. 68-D4-0005, W. A. 32
12. SPONSORING AGENCY NAME AND ADDRESS EPA, Office of Research and Development Air Pollution Prevention and Control Division Research Triangle Park, NC 27711		13. TYPE OF REPORT AND PERIOD COVERED Published paper; 11/94-5/95
		14. SPONSORING AGENCY CODE EPA/600/13
15. SUPPLEMENTARY NOTES APPCD author Borgwardt's mail drop is 63; his phone number is 919/541-2336. For presentation at ACS Symposium on CO₂ Capture, Utilization, and Disposal, Orlando, FL, 8/25-29/96.		
16. ABSTRACT The paper discusses the use of a thermobalance reactor to evaluate the reactivity of poplar wood in gasification under the operating conditions specific for the Hynol process (30 atm and 800 C). The gasification involved a rapid devolatilization and pyrolysis reaction of the volatile matter in biomass and a slow reaction of residual carbon with the process gas. Nearly 86% of 01/8-in. (0.3 cm) diameter poplar particles and 90% of sawdust could be converted into gas products by a feed gas corresponding to the Hynol process (66% hydrogen) in 60 min. About 4% additional conversion of 1/8-in. particles was obtained when gasification time was extended to 150 min. Gasification rate and biomass conversion were strongly affected by reaction temperature and particle size. The conversion was proportional to the partial pressures of hydrogen and steam in the feed gas. A kinetic model was developed to correlate the experimental data and quantitatively express gasification rates and biomass conversion as functions of reaction time. The activation energies for the rapid and slow reactions were estimated to be 3.8 and 34 kcal/mol, respectively.		
17. KEY WORDS AND DOCUMENT ANALYSIS		
a. DESCRIPTORS	b. IDENTIFIERS/OPEN ENDED TERMS	c. COSATI Field/Group
Pollution Kinetics Fuels Carbinols Biomass Gasification Poplar Wood Sawdust	Pollution Control Stational Sources Hynol Process Modeling	13B 20K 21D 07C 08A, 06C 13H, 07A 11L
18. DISTRIBUTION STATEMENT Release to Public	19. SECURITY CLASS (This Report) Unclassified	21. NO. OF PAGES
	20. SECURITY CLASS (This page) Unclassified	22. PRICE